

QUADREL

LABELING SYSTEMS

Operating & Maintenance
Manual
For

CAL SIERRA INTERNATIONAL

ML125

Automatic Labeling System

Labeler Model #: Q125 SERVO
Serial #: 84272-100

QUADREL LABELING SYSTEMS
7670 Jenther Drive
Mentor, Ohio 44060
440.602.4700

customerservice@quadrel.com
parts@quadrel.com

TERMS AND CONDITIONS OF SALE

QUADREL, INC

D/B/A Quadrel Labeling Systems Hereinafter Referred to as Quadrel

PERFORMANCE GUARANTEE:

If the surface of the product to be labeled is free from contamination so as to ensure proper label adhesion, the labels are manufactured in accordance with label specifications provided and the equipment is operated and maintained in accordance with the instructions contained in the Quadrel manual (two copies of the manual will be supplied by Quadrel with the labeling system; one printed copy, and one electronic copy). Quadrel guarantees the EQUIPMENT to perform after installation as stated.

1. Provided a sufficient amount of products are presented to the labeling system.
2. Dimensional inconsistency from one like product to be labeled to the other may result in additional label placement inaccuracy in direct relationship to the product inconsistency.
3. Slitting inconsistency within a given roll of labels or from one like roll to another may result in additional label placement inaccuracy in direct relationship to the slitting inconsistency.
4. If the Quadrel labeling system proposed herein does not include physical control of the product during label application, additional placement inaccuracy can occur in direct relationship to the product control inconsistency.
5. Label Placement Accuracy: Within Sigma 2 (approximately 95.5%) to be normal.

In the event of the failure if the Quadrel system to meet customer's specifications, as quoted by Quadrel or subsequently agreed to by Quadrel. Quadrel upon written notice from buyer shall, at its option, repair the system, or refund the purchase price upon return of the system. The warranty provided in this article and the obligations and liabilities of Quadrel thereunder are exclusive and in lieu of, and buyer hereby waived, other remedies warranties, guarantees or liabilities, express or implied arising by law or otherwise (including without limitation, any obligations of Quadrel with respect to fitness for a particular purpose, merchantability, specific performance, incidental and consequential damages) whether or not occasioned by Quadrel's negligence. This warranty should not be extended altered or varied except by written instrument signed by Quadrel and buyer.

EXCLUSIVE TERMS OF SALE: The proposal attached hereto or to which these Terms and Conditions of Sale apply (the "Proposal"), together with these Terms and Conditions of sale (collectively, the "Sale Agreement"), constitutes the complete and exclusive statement of the agreement between Quadrel and the purchaser specified in the Proposal ("Purchaser") concerning the equipment and other goods specified in the Proposal (collectively, the "Equipment"), as well as any and all services specified in the Proposal (collectively, the "Services"), and supersedes all prior contemporaneous agreements, representations and/or communications, either oral or written, between Quadrel and Purchaser or any representative such as parties with the respect to the subject matter of the Sale Agreement. No change to the Sale Agreement or waiver of any provision thereof will be binding on Quadrel unless made in writing and signed off by and authorized officer of Quadrel. Acceptance of the Equipment, in whole or part, or other express or implied assent by Purchaser to the terms hereof shall constitute Purchaser's agreement to the terms of the Sale Agreement. Acceptance of any purchase order or other document of Purchaser by Quadrel is expressly made conditional on the Purchaser's assent to the Sale Agreement. ANY ATTEMPTED MEMORIALIZATION OF THIS SALE BY A PURCHASE ORDER OR OTHER DOCUMENT CONTAINING TERMAND CONDITIONS INCOSISTANT WITH OR IN ADDITION TO THE CONDITIONS CONTAINED IN THE SALE AGREEMENT SHALL NOT BE BINDING UPON QUADREL AND QUADREL HEREBY EXPRESSLY OBJECTS TO AND REJECTS THE SAME.

GENERAL WARRANTY (EXCLUDES TABLETOP LABELERS)

Time from date of shipment	Covered Expenses
Up to 90 Days	All Parts , service time, living and travel expenses
UP to 12 Months	All parts

THE WARRANTIES PROVIDED ABOVE ARE IN LIEU OF ANY AND ALL OTHER WARRANTIES AND LIABILITIES, EXPRESSED OR IMPLIED, INCLUDING BUT NOT LIMITED TO ANY WARRANTIES OF MERCHANTABILITY OR FITNESS FOR ANY PARTICULAR PURPOSE. NO OTHER WARRANTIES ARE OFFERED BY QUADREL WITH RESPECT TO THE EQUIPMENT OR SERVICES AND QUADREL HAS NOT AUTHORIZED ANY EMPLOYEE OR AGENT TO OFFER ANY WARRANTIES EXCEPT THOSE PROVIDED ABOVE. PURCHASER AND QUADREL EXPRESSLY AGREE THAT THE WARRANTIES PROVIDED ABOVE SHALL SERVE AS PURCHASER'S SOLE AND EXCLUSIVE REMEDY WITH RESPECT TO THE EQUIPMENT AND SERVICES.

PURCHASER REQUIREMENTS. Purchaser must provide Quadrel descriptions and specifications of all labels and items to be labeled, including, without limitation, label material, product and label dimensions, and any other items required by Quadrel. Further, purchaser shall furnish Quadrel one (1) production size roll of each label and 100 samples of each item to be labeled for testing purposes. **Quadrel shall have no liability (whether under its Limited One-Year Warranty or otherwise) for labeling performance on labels or items to be labeled:**

- (a) Which were not specified or sufficiently described in the Proposal: or**
- (b) With respect to which Purchaser fails to provide Quadrel the samples specified herein, even if such labels or items to be labeled were specified in the Proposal. Further, Quadrel shall have no liability for delays caused by Purchaser's failure to furnish samples as specified herein.**

LIMITATION OF WARRANTIES. Quadrel shall have no obligation to honor its warranties and shall have no liability with respect to defective Equipment if:

- (a) The Equipment has been modified, altered, damaged, abused or used for any other than those purposes intended by Quadrel.
- (b) The Equipment has been changed without prior written consent from Quadrel.
- (c) The equipment has not been operated and maintained in accordance with generally accepted commercial practices for similar equipment and Quadrel's specifications and instructions, as published in the Quadrel manual.
- (d) The surface if the product to be labeled is not clean and free of contamination, including, but not limited to, mold release agents, condensation, dirt and oil.
- (e) Labels are not manufactured in accordance with label specifications provided by Quadrel, or are not from defects such as cracked edges, deep die strikes, *etc.*
- (f) Labels and items to be labeled are not set forth in the Proposal.
- (g) Samples of all products and labels were not provided to Quadrel for testing prior to Equipment shipment as required under "Purchaser Requirements" outlined above.
- (h) There is dimensional inconsistency from one like roll of labels to another.
- (i) *The Equipment does NOT include physical control of the product.*

LIMITATION OF REMEDIES. All warranty claims shall be subject to review and approval by Quadrel. Quadrel's obligation to honor warranties is in all cases limited to, at Quadrel's sole option:

- (a) Repair of defective Equipment or components: or
- (b) Providing a cash refund or credit, after Purchaser has returned Equipment to Quadrel.

Where warranty service is to be provided at the Quadrel facility, Purchaser shall return Equipment claimed to be defective to Quadrel, freight prepaid, for review. No Equipment shall be returned to Quadrel, whether for inspection, repair, refund, or any other reason, without prior return authorization from Quadrel. Quadrel may charge Purchaser cost resulting from testing, handling and disposition of Equipment claimed to be defective by Purchaser which is found by Quadrel to conform to Quadrel's warranties.

LIMITATION OF LIABILITY. QUADREL SHALL HAVE NO LIABILITY FOR ANY CONSEQUENTIAL, INCIDENTAL, PUNITIVE OR SPECIAL DAMAGES BY REASON OF ANY ACT OR OMISSION OR ARISING OUT OF OR IN CONNECTION WITH THE (a) EQUIPMENT OR ITS SALE, DELIVERY, INSTALLATION, MAINTENANCE, OPERATION, OR PERFORMANCE, OR (b) SERVICES. IN NO EVENT SHALL QUADREL'S LIABILITY EXCEED THE PRICE OF THE EQUIPMENT (OR THE PRICE OF THE SERVICES IF A CLAIM IS MADE WITH RESPECT TO THE SERVICES) WITH RESPECT TO WHICH A CLAIM IS MADE REGARDLESS OF WHETHER SUCH CLAIM IS BROUGHT

AT LAS OR IN EQUITY AND REGARDLESS OF WHETHER SUCH CLAIM IS BROUGHT UNDER CONTRACT, BREACH OF WARRANTY, TORT OR ANY OTHER THEORY OF LAW OR EQUITY.

ORDERS:

Orders entered, verbal or written, cannot be cancelled except upon terms that will compensate Quadrel against any and all claims

START-UP SERVICE:

Quadrel will provide, at standard installation rates, the number of normal eight-hour working days for the Quadrel Field Service Technician to start the EQUIPMENT and to train PURCHASER'S operating and maintenance personnel. EQUIPMENT is not uncrated and emplaced in desired location by PURCHSER prior to arrival of Quadrel Field Service Technician, or if the EQUIPMENT cannot be made operational due to non-availability of products, labels, appropriate utilities and/or related production equipment, PURCHASER shall pay Quadrel for additional service time required including travel expenses, if applicable, in accordance with Quadrel's Field Service rates. It is PURCHASER's obligation to schedule the start-up service at a time when PURCHSER'S engineering, maintenance and selected production personnel are available.

SERVICE AFTER INSTALLATION:

Quadrel Field Service Technicians are available to customers who do not maintain their own service departments. This can be handles on a per visit basis. Field Service rates are available on request.

PAYMENT TERMS:

Payment terms are as follows: 50% of purchase with purchase order, 40% of purchase at the time of shipment, 10% of purchase (plus freight charges) due net 30 days. If shipment is delayed beyond 30 days after the EQUIPMENT has been made ready for shipment, and the delay is caused directly or indirectly by the PURCHASER, then the total of the unpaid balance, at option of Quadrel, may become immediately due and payable upon written notice. Payments not paid when due shall thereafter bear monthly service charges at the rate of 1.5% per month on the unpaid balance until paid. If, in Quadrel's opinion, PURCHASER'S financial condition does not justify continuance of production or shipment on the terms of payment specified above, Quadrel may require payments in advance.

FINANCIAL IMPAIRMENT. Quadrel may, at its option, suspend performance if in its opinion the credit of the Purchaser becomes impaired until such time as Quadrel has received full payment, including any general price increases or surcharges, is satisfactory security for deliveries made and is satisfied as to Purchasers credit for future deliveries. Quadrel reserves the right to cancel Purchaser's credit at any time for any reason. In addition, Quadrel reserves the right by written notice to cancel any order or require full or partial payment or adequate assurance of performance from Purchaser without Liability to Quadrel in the event of:

- (a) Purchaser's insolvency
- (b) Filing of a voluntary petition in bankruptcy by Purchaser
- (c) Filing of an involuntary petition in bankruptcy against Purchaser
- (d) Appointment of a receiver or trustee for Purchaser
- (e) Execution by Purchaser of an assignment for the benefit of creditors

TAXES:

The amount of any present or future federal, state, local or other taxes applicable to the sale of EQUIPMENT shall be added to the price and paid by PURCHASER unless PURCHASER provides a valid exemption certificate acceptable to Quadrel and the appropriate tax authority.

GOVERNING LAW AND JURISDICTION. The sale agreement shall be governed and construed in accordance with the domestic laws of the State of Ohio without giving effect to any choice or conflict of law provision or rule that would cause the application of the laws of any jurisdiction other than the State of Ohio. Any legal action, suit or proceeding relating to the Sale Agreement shall be heard and determined exclusively in the United States District Court for the Northern District of Ohio or the Court of Common Pleas of Lake County, Ohio, and each party irrevocably submits to the jurisdiction of either such courts and waives any objection which such party may have to the laying of venue of any such legal action, suit or proceeding in any such court.

The Sale Agreement shall not be governed by the United Nations Convention on the International Sales of Goods. No actions arising out of the sale of Equipment or Services may be brought by either party more than one (1) year after shipment.

RETURNS:

EQUIPMENT sold by Quadrel is returnable only in accordance with the provisions hereof. Before returning of any EQUIPMENT or items thereof, PURCHASER must obtain Quadrel's written return authorization and instructions.

FORCE MAJEURE:

Quadrel shall not be liable for any loss, damage, delay, changes in shipment schedules or failure to deliver due to act of God, accidents, fires, strikes, riots, civil commotion, insurrection, war, the elements, embargoes, failure of carriers, inability to obtain electricity or other type of energy, transportation facilities, raw material, equipment or any problem or any similar or different contingency beyond its reasonable control which would make performance commercially impractical whether or not the contingency is of the same class as those above. Quadrel shall in no event be liable for any consequential damages.

TITLE AND RISK OF LOSS:

Title and risk of loss to EQUIPMENT shall pass to PURCHASER upon delivery by Quadrel to a common carrier, regardless of the freight terms stated or method of payment for transportation charges. Quadrel reserves the right to specify routing of shipments.

ENTIRE AGREEMENT:

This agreement embodies the entire agreement and understanding between the parties, is intended as complete and exclusive statement of terms of the agreement between the parties and supersedes any prior agreements or understandings between the parties relating to the subject matter hereof. PURCHASER acknowledges that Quadrel has not made any representations to PURCHASER other than those which are contained herein. Except as provided in this agreement, no change in or addition to the terms contained herein shall be valid as between the parties unless set forth in writing which is signed by an authorized representative of both parties and which specifically states that it constitutes an amendment to this agreement.

The parties may use their normal commercial forms in connection herewith: however, any such forms shall be used for convenience only and any terms or provisions which may be contained therein inconsistent with or in addition to those contained herein shall have no force or effect whatsoever between parties hereto.

EFFECTIVE:

This proposal is based upon the current cost of labor and materials and shall remain in effect for a period of sixty (60) days from the date hereof unless revoked by Quadrel in writing prior to acceptance.

INDEMNIFICATION:

The purchaser of this product ("Customer") hereby agrees to release, indemnify and hold harmless Quadrel and its agents, assignees and representatives for any and all liabilities, losses, costs, damages and expenses (including attorneys' fees and expenses) arising, directly or indirectly, from any and all manner of claims, demands, actions and proceedings that may be instituted against Quadrel on any grounds.

The Customer agrees to, at the Customer's own expense, promptly defend and continue the defense of any such claim, demands, actions or proceeding that may be brought against Quadrel, provided that Quadrel shall, within thirty (30) days of Quadrel receiving notice thereof, notify the Customer of such claims, demand, action or proceeding.

Quadrel shall at all times retain the right to defend itself and/or to otherwise participate in the defense of any such claim or action, and no settlement or other resolution of any such claims or action shall be finalized without Quadrel's written approval. Any failure by Quadrel to give prompt notice or provide copies of documents or furnish relevant data shall not constitute a defense in whole or in part to any claim by Quadrel against the Customer except to extend that such failure by Quadrel shall result in a material prejudice to the Customer.

The forgoing notwithstanding, if suit shall have been against Quadrel and the Customer shall have failed, after the lapse of a reasonable time after written notice to it of such suit, to take action to defend the same. Quadrel shall have the sole right to

defend the claim and shall be entitled to charge the customer with the reasonable cost of any such defense, including reasonable attorney's fees, and Quadrel shall have the right, after notifying but without consulting the Customer, to settle or compromise such claim on any terms reasonably provided by Quadrel.

This release and indemnification is and shall be binding upon the Customer, as well as the Customer's respective heirs, subsidiaries, affiliates, successors, assigns, agents and employees. If any provision or provisions of this release and indemnification shall be held to be invalid, illegal or unenforceable for any reason whatsoever, the validity, legality and enforceability of the remaining provisions of this Agreement shall not in any way be affected or impaired thereby. No supplement, modification or amendment of this Agreement shall be binding unless executed in writing by all of the parties hereto.

Any order put on hold or left dormant for any reason for 90 days will be considered cancelled. See Cancellation Policy below.

CANCELLATION POLICY:

In the event of order cancellation, the 50% down payment is non-refundable. Customer may also be responsible for additional charges covering engineering resources expended and committed materials depending upon the custom nature of the project and the point in the order process in which the cancellation occurs.

NOTE. No salesman, representative or agent of Quadrel is authorized to give a guarantee, warranty or make any representation contrary to above.

Please sign and acknowledge acceptance to these terms and conditions _____ Date _____

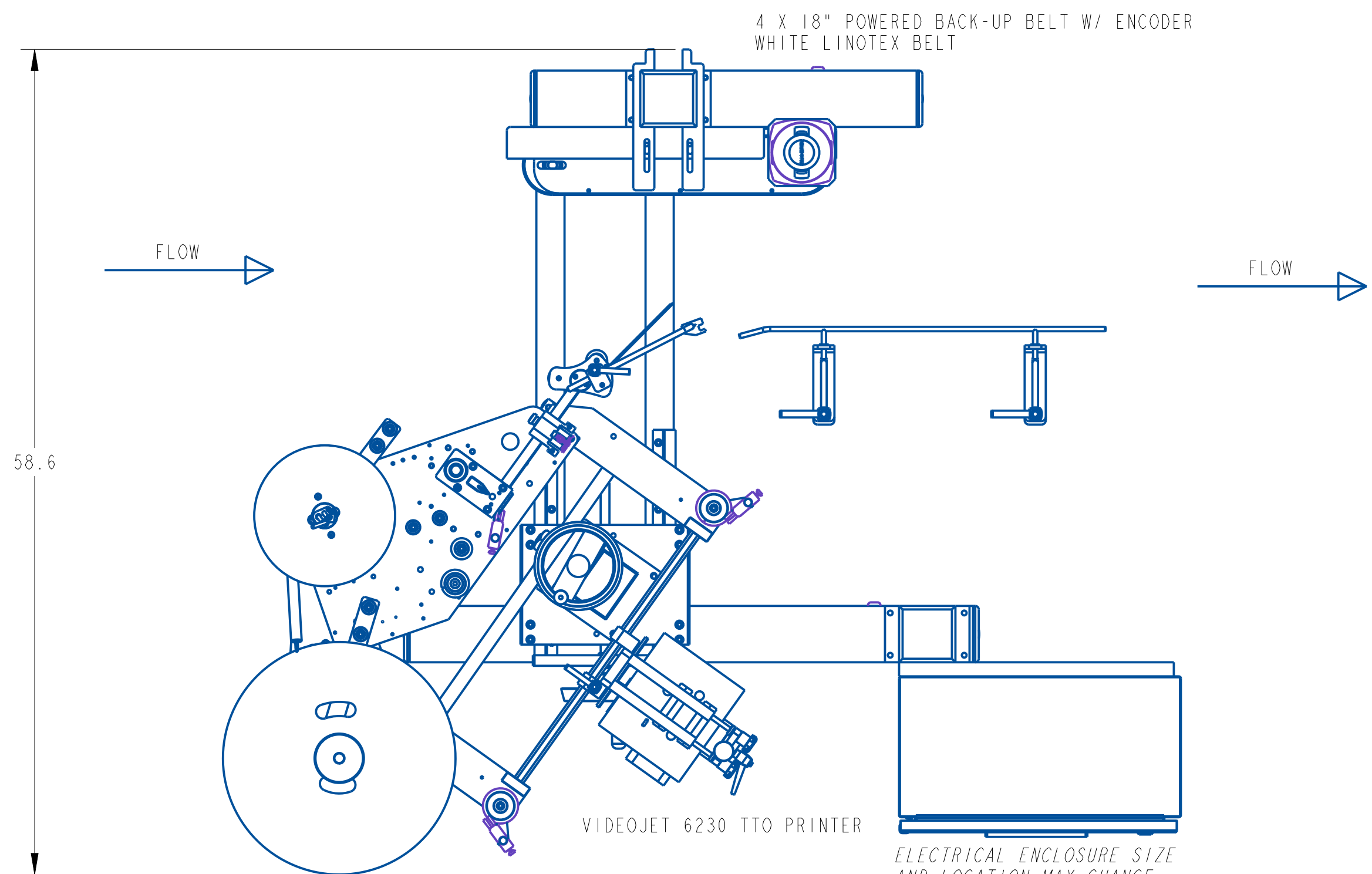

LH 7" Q125 SERVO LABELING HEAD
STANDARD LABEL SENSOR
FAULTS:
LOW LABEL - AMBER LIGHT/ AUDIBLE
BROKEN WEB - RED LIGHT/AUDIBLE
END OF WEB - RED LIGHT/AUDIBLE
COPY 3 POSITION LABEL

ELECTRICAL ENCLOSURE SIZE
AND LOCATION MAY CHANGE
DUE TO COMPONENTS AND
REQUIREMENTS

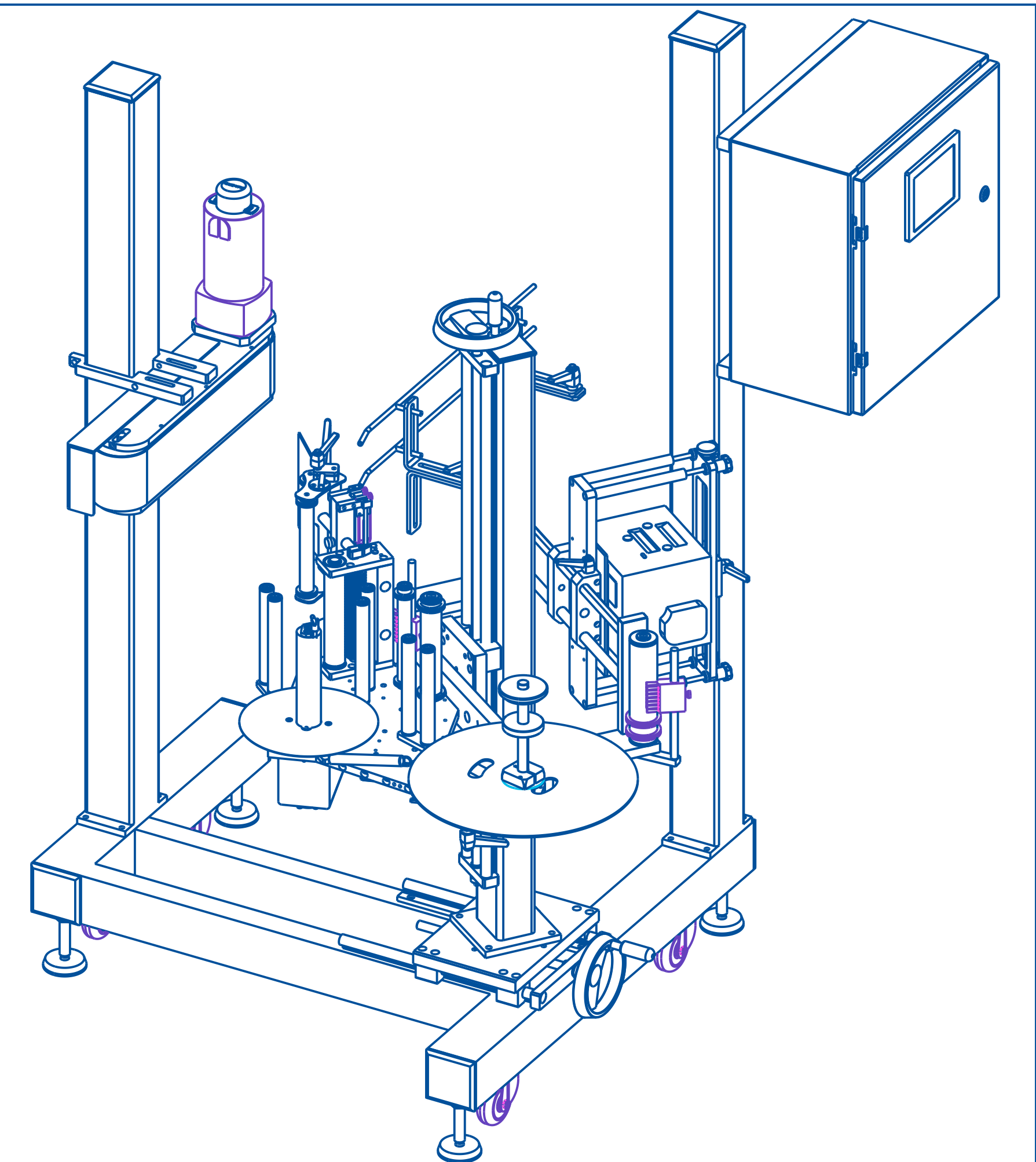
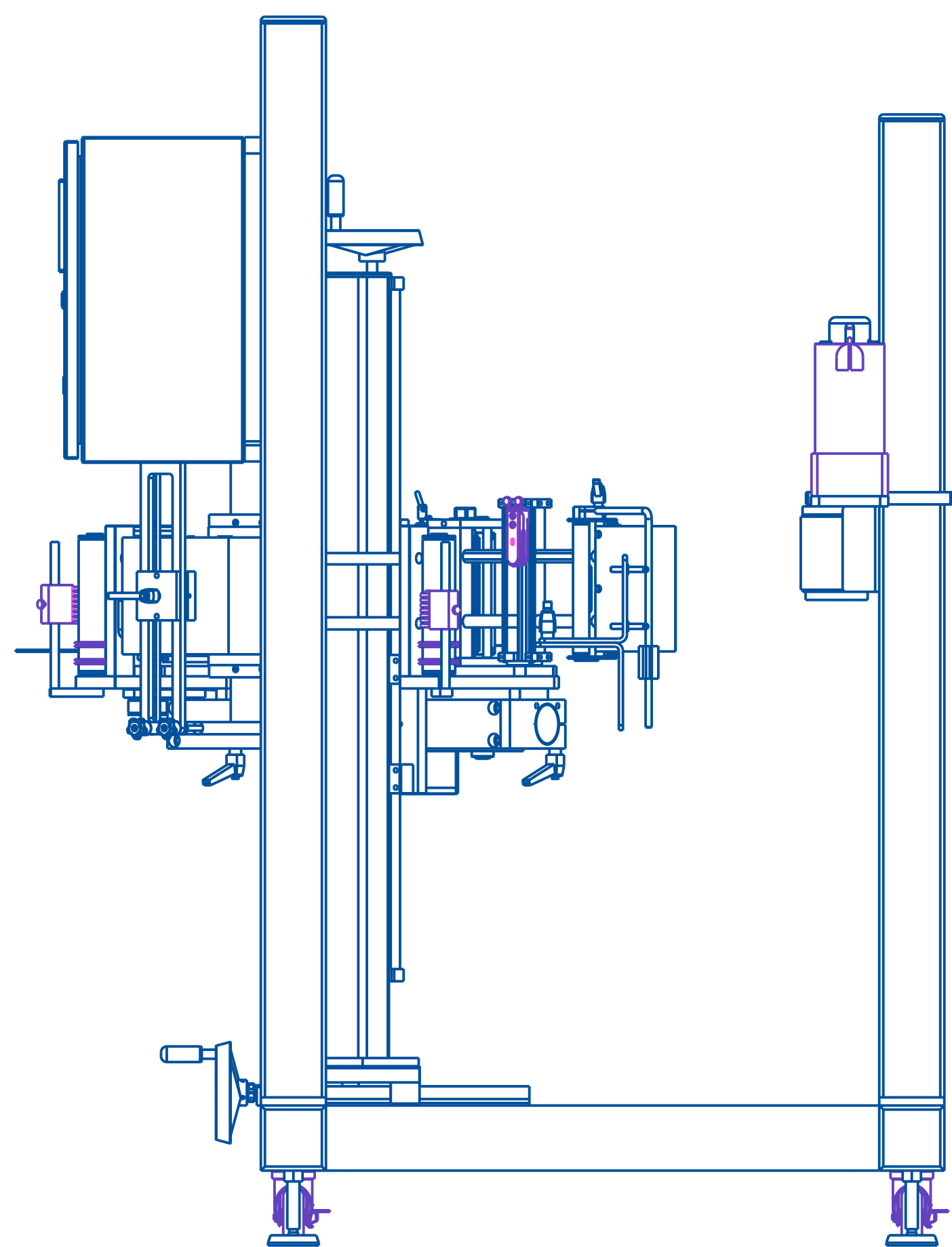
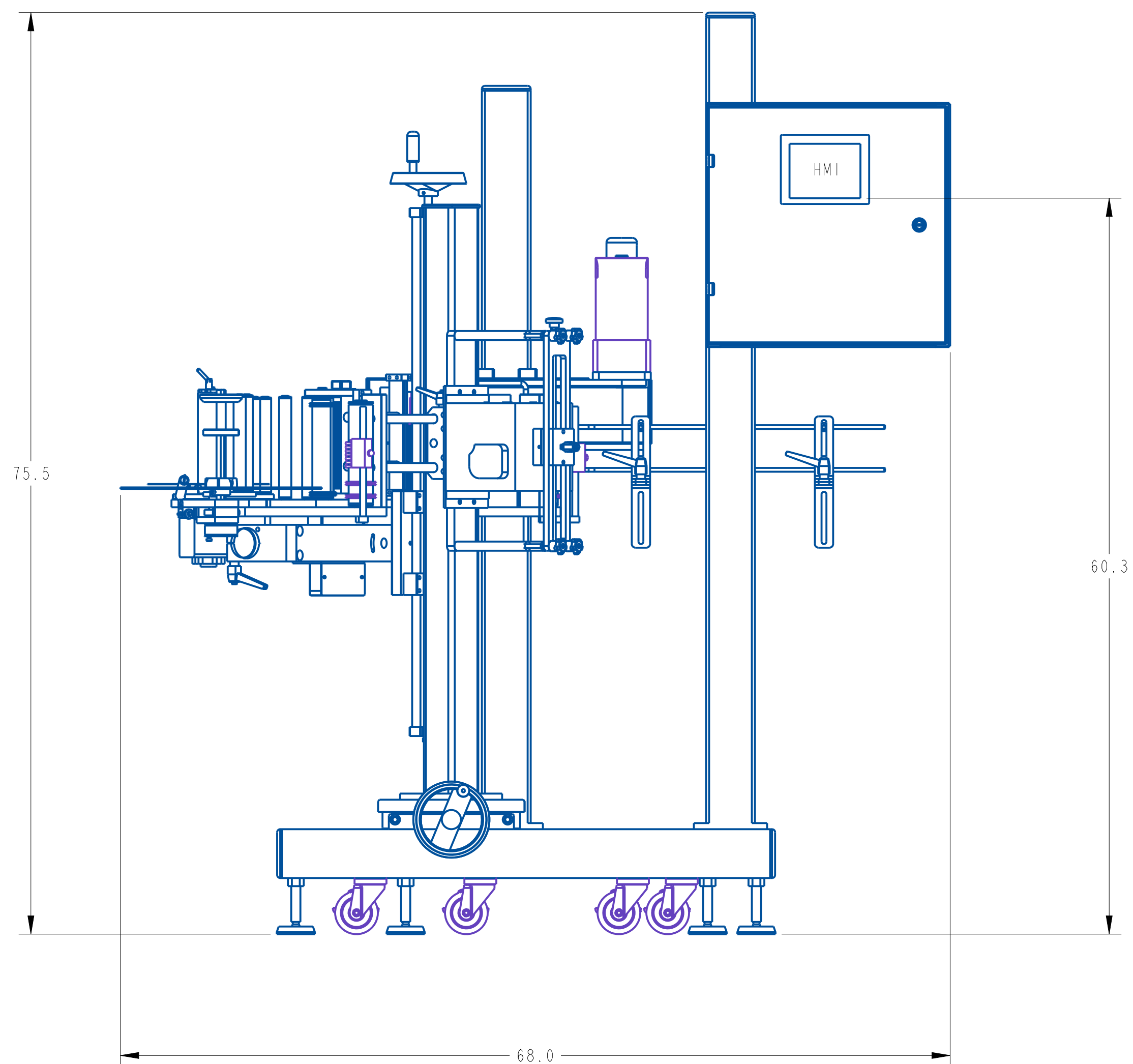

A	Feb-12-26	NEW DRAWING	TAZ
REV	DATE	DESCRIPTION	BY

THIS IS A PRO-ENGINEER DOCUMENT AND MAY NOT BE MODIFIED MANUALLY

<small>UNLESS OTHERWISE SPECIFIED DIMENSIONAL TOLERANCE</small> X ± .1 XX ± .01 XXX ± .005 ANGLES ± .30° SURFACE FINISH 125 BREAK ALL EDGES .005/.015 CORNER RADIUS .010/.030 ALL ANGLES ARE 90°	 QUADREL LABELING SYSTEMS 7670 JENTHER DRIVE MENTOR, OHIO 44060 (440) 602-4700	SCALE: 1/8
		DATE: Feb-12-26
		DRW BY: TAZ
		CHK BY:
ML60 WITH POWERED BACK BELT LABELING SYSTEM		APPR BY:
MAT'L	CAL SIERRA INTERNATIONAL	84272-100
APPROVAL DRAWING		

TABLE OF CONTENTS

1	MANUAL PREFACE
2	GENERAL DISCRIPTION
3	WARNING/CAUTION SAFETY INSTRUCTION
	3.1 SAFETY INTEGRATION
	3.2 GENERAL SAFETY INFORMATION
4	INSTALLATION / REASSEMBLY INSTRUCTIONS
5	HMI GUIDE
6	SET UP SHEETS
7	LABELING HEAD
	7.1 LABELING HEAD INFORMATION
	7.1.1 LOADING AND UNLOADING STOCK ROLL
	7.1.2 THREADING DIAGRAMS
	7.1.3 LABELER ADJUSTMENTS
	7.1.4 FUNCTION, OPERATION, & TROUBLESHOOTING
	7.2 SIDE PLATE ASSEMBLY
	7.2.1 ASSEMBLY WRITE UP
	7.2.2 DRAWING
	7.3 UNWIND ASSEMBLY
	7.3.1 ASSEMBLY WRITE UP
	7.3.2 DRAWING
	7.4 PEEL PLATE ASSEMBLY
	7.4.1 ASSEMBLY WRITE UP
	7.4.2 DRAWING
	7.5 BRUSH IMPRESSER ASSEMBLY – (OPTIONAL)
	7.5.1 ASSEMBLY WRITE UP
	7.5.2 DRAWING
	7.6 DRIVE AND PINCH ROLL ASSEMBLY
	7.6.1 ASSEMBLY WRITE UP
	7.6.2 DRAWING
	7.7 STEPPER/SERVO MOTOR DRIVER ASSEMBLY
	7.7.1 ASSEMBLY WRITE UP
	7.7.2 DRAWING
	7.8 REWIND ASSEMBLY
	7.8.1 ASSEMBLY WRITE UP
	7.8.2 DRAWING
	7.9 SLOT SENSOR ASSEMBLY
	7.9.1 ASSEMBLY WRITE UP

- 7.9.2 DRAWING
- 7.10 LABELING HEAD FAULTS – **(OPTIONAL)**
 - 7.10.1 ASSEMBLY WRITE UP
 - 7.10.2 DRAWING
- 7.11 PRODUCT DETECT ASSEMBLY
 - 7.11.1 ASSEMBLY WRITE UP
 - 7.11.2 DRAWING
- 7.12 STAND – **(OPTIONAL)**
 - 7.12.1 ASSEMBLY WRITE UP
 - 7.12.2 DRAWING
- 7.13 YOKE ASSEMBLY –**(OPTIONAL)**
 - 7.13.1 ASSEMBLY WRITE UP
 - 7.13.2 DRAWING
- 8 ELECTRONICS
- 9 MAINTENANCE
 - 9.1 GENERAL INFORMATION
 - 9.2 BELTS
 - 9.3 ROLLERS
 - 9.4 SENSORS
 - 9.5 CONVEYOR
 - 9.5.1 CLEANING
- 10 WARRANTY



Quadrel Labeling Systems Quality Manual

Quality Statement:

Quadrel Labeling Systems strives to provide our customers with the highest quality labeling/sleeving solutions available on the market. In order to achieve total customer satisfaction, we shall adhere to the following objectives:

100% on-time delivery

zero defects

Value added service and support

Engineered solutions

Employee development and diversity

We will commit to continuously improve each facet of our business operations through implementation of, and compliance of this manual.

A handwritten signature in black ink, reading "C. Wepler".

Chuck Wepler
General Manager / President

1 MANUAL PREFACE

Thank you for choosing Quadrel Labeling Systems. We have designed and manufactured this equipment with the upmost pride and care ensuring you the absolute best quality, maximum versatility and reliability.

This equipment is intended to be used only as described in this document. Quadrel Labeling Systems Inc. cannot be held responsible for the improper use or functioning of non-described functions of this machinery. Liability for any personal injury, loss of production or revenues, or property damage occasioned by the use of this manual in effect maintenance, operation, or repair of the equipment is in no way assumed by Quadrel Labeling Systems Inc. Anyone one using a procedure not recommended by the end user should first completely satisfy himself/herself that personal safety and equipment integrity will not be jeopardized in the method selected.

DO NOT attempt to install, operate, or adjust the labeling system without first reading and understanding the contents of this manual.

Only a trained person is to be permitted to operate this equipment. Training should include instruction in operation under normal conditions and emergency situations. Under no circumstances should an untrained person operate this machine.

This manual will provide operating instructions, parts listing and schematics. The information contained in this manual will help the user in his/her operations, troubleshooting, and maintaining the machine in good operating conditions. Information, illustrations and specifications contained in this manual are based on the latest product information available at the time of this manual release. Quadrel Labeling Systems Inc. reserves the right to alter and substitute information contained herein at any time.

Due to the customization it is also possible that you have received a different variation of this equipment, with several different options. Some pictures used in this manual may not totally reflect your configuration, although the labeling is completely the same.

All rights reserved while every precaution has been taken in the preparation of this manual, Quadrel Labeling Systems Inc. cannot be held responsible for errors, omissions, damages, loss of production, or revenues resulting from the use of the information contain herein.

3 WARNING/CAUTION SAFETY INSTRUCTION

Where safety is dependent upon starting or stopping devices, or both, they are to be kept free of obstructions that could endanger personnel.

The areas around loading and unloading points are to be kept free of obstructions that could endanger personnel. Instruct personnel working on or near this equipment as to the location and operation of pertinent stopping devices.

This equipment is to be used only for the purpose for which it is constructed.

Under no circumstances are the safety characteristics of this equipment to be altered.

Conduct routine inspections and corrective / preventive maintenance measures to ensure that all guards are installed and function properly. Alert personnel to the potential hazards indicated by the safety labels on this equipment.

3.1 SAFETY INTEGRATION

The end user's safety risk assessment will be the guiding document for proper integration of the equipment provided. Consideration of the following guidelines is recommended in order to achieve a safe result:

- Open areas under the equipment are to be guarded by the end user to prevent entry.
- Where conveyor flight lugs or product enters or exits the equipment, proper guarding and interlock are put in place by the end user to ensure mitigation of shear/jam points.
- The end user is responsible for properly guarding drive components on equipment that requires mechanical drive integration.

3.2 GENERAL SAFETY INFORMATION

This Quadrel Labeling System is engineered to feed and apply labels on your products. In designing the device, Quadrel valued personal safety; however we would like to draw your attention to the following safety acknowledgments.

 **WARNING** Hazards or unsafe practices, which **COULD** result in severe personal injury or death.

 **CAUTION** Hazards or unsafe practices, which **COULD** result in minor injury

 **CAUTION** The presence of safety systems in these units does not exempt the operators to act cautiously, avoiding behaviors that could

endanger their health or the equipment. These models are engineered to feed and apply labels on your products. In designing this device, Quadrel valued personal safety; however we would like to draw your attention to the following safety acknowledgments.

- Operators should know the basic operations and setup procedures before operating this equipment.
- Safe operations should be maintained at all times.
- Know the location of E-stops and power switches prior to operating machinery such as this.

 **WARNING**

To reduce risk of fire, electrocution, or other personal injury when operating. Follow basic safety precautions, including the following:

- This equipment must have an operator attending the machine at all times to monitor the operations. **DO NOT** leave this equipment unattended during maintenance or perform any maintenance unless the e-stop condition has been activated or power turned off.
- The electrical power to device is: ___110___ Volts, ___SINGLE (1)_Phase, ___60___Hz, ___10___Amps. While installing make sure it's properly configured and connected by a qualified electrical technician.
- **DO NOT** by pass any of the safety circuits or safety features designed into this equipment.



- ALWAYS turn off **power and pneumatics** before performing repairs.
- The doors on all electrical enclosures must be closed. All covers on labeling heads must be on labeling heads. (if applicable)
- This device is built to perform in humid conditions, but must not be pressure washed. Wiping down the device is the recommended cleaning method.



- Do not stand, sit, or allow any personnel to be within reach of the tamp cylinder/ swing arm activation (if so equip).
- Report any malfunctions, or problems with the equipment to qualified maintenance personnel for repair or adjustments that may be required.
- Keep hands clear of moving parts. Do not place hands near labeling head when in operation.



For systems containing conveyors, you must be vigilant with loose clothing or bodily parts as they can get caught in the conveyor's belt or chains as direct injury or death can incur. **DO NOT** use the conveyor as a working platform or walkway.

TUCK IN ANY LOOSE CLOTHING. DO NOT WEAR TIES. PENDANTS, JEWELRY OR ANY OTHER ARTICLE OF CLOTHING OR ACCESSORY THAT MAY GET CAUGHT ON ANY PORTION OF THE SYSTEM.

FOR PROLINE SYSTEMS ONLY

CASTERS WERE IMPLEMENTED FOR EASE OF SHIPPING PURPOSES ONLY. PLEASE USE CAUTION WHEN MOVING PROLINE THROUGH FACILITY. THE PROLINE RECOMMENDED USE: SET IN PLACE/POSITION WITH LEVELING PADS DOWN TO SECURE.

WARNING

- 1. READ AND UNDERSTAND THE OPERATION MANUAL AND ALL SAFETY LABELS BEFORE OPERATING THIS MACHINE.**
- 2. ONLY A TRAINED PERSON IS TO BE PERMITTED TO OPERATE THIS MACHINE. TRAINING SHOULD INCLUDE INSTRUCTION IN OPERATION UNDER NORMAL CONDITIONS AND EMERGENCY SITUATIONS.**
- 3. THIS MACHINE IS TO BE SERVICED ONLY BY TRAINED AND AUTHORIZED PERSONNEL. FOLLOW LOCK-OUT PROCEDURES BEFORE SERVICING.**
- 4. NEVER REACH INTO THE MACHINE FOR ANY REASON UNLESS THE MACHINE IS AT A COMPLETE STOP.**
- 5. NEVER LEAVE THE MACHINE STOPPED IN SUCH A MANNER THAT ANOTHER WORKER CAN START THE MACHINE WHILE YOU ARE WORKING ON OR WITHIN THE MACHINE.**
- 6. NEVER CHANGE OR DEFEAT THE FUNCTION OF ELECTRICAL INTERLOCKS OR OTHER MACHINE "SHUTDOWN" SWITCHES.**
- 7. BEFORE STARTING THIS MACHINE, CHECK THAT: ALL PERSONS ARE CLEAR OF THE MACHINE; NO MAINTENANCE WORK IS BEING PERFORMED ON THE MACHINE, ALL GUARDS ARE IN PLACE.**
- 8. ROUTINE INSPECTIONS AND CORRECTIVE/PREVENTATIVE MAINTENANCE MEASURES ARE TO BE CONDUCTED TO ENSURE THAT ALL GUARDS AND SAFETY FEATURES ARE RETAINED AND FUNCTION PROPERLY.**

Using VFDs On GFCI Devices

By Bill Szatkiewicz, Senior Software Engineer
KB Electronics

for more information, email: info@kbelectronics.net
or visit: www.kbelectronics.com

The National Electrical Code, or NEC, continues to expand protection requirements for safety reasons resulting in an increase in Ground-Fault Circuit-Interrupter (GFCI) outlets being used in more environments. As a result, the Variable Frequency Drives (VFDs) industry is finding more instances of VFDs being powered from GFCIs. VFDs introduce high frequency harmonic content which may cause nuisance tripping on some GFCI devices. This paper is intended to assist anyone that needs to use a VFD on a circuit with GFCI protection. KB Electronics has developed special VFDs suitable for use with most GFCIs*.

* Please contact KB Electronics with information regarding your specific GFCI.

What is a VFD?

A VFD (also termed adjustable frequency drive, variable speed drive, AC drive, adjustable speed drive, micro drive, motor control, or inverter drive) is a power conversion device that will accept normal fixed branch circuit voltage of (115V or 230V) and frequency (50 Hz or 60 Hz) and allow the operator to control the speed of an induction motor (AC Motor) by varying the output voltage and frequency. A simplistic version of a typical VFD system is shown in Figure-1.

In addition to operator controllability, the VFD with soft start/stop features offers extended equipment life, increased performance, reduced maintenance, protection from excessive currents and voltages, as well as energy savings.

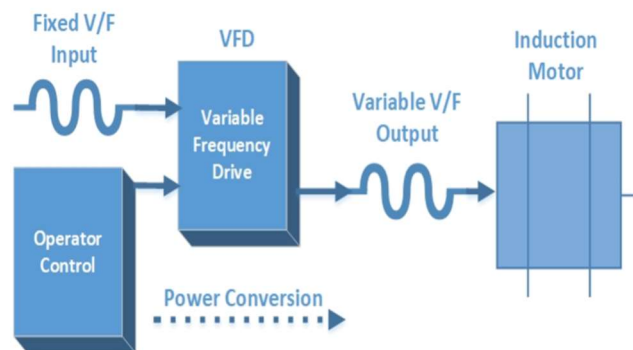

Figure-1: Typical VFD System

What is a GFCI?

A GFCI (shown in Figure-2) is a circuit breaker device which is designed to protect people from hazardous shock or electrocution by shutting off an electric power circuit when it detects current flowing in a way that it is not meant to, such as through water or a person.



Figure-2: Typical GFCI Outlet

The GFCI is intended to protect people from electrical shock, therefore, it is completely different from a fuse in the sense that it needs to shut off the electric power circuit at a low current, typically no more than 5 mA, in a quick amount of time (less than 1/10 of a second).

The GFCI does this by measuring and comparing the amount of current flowing in the ungrounded (hot) and grounded (neutral) conductors of the circuit. If the GFCI detects an imbalance in the circuit, it immediately shuts off the circuit.

Why Nuisance Trips Occur with Standard VFDs

Standard VFDs, when powered from GFCI outlets, can cause the GFCI to trip due to the leakage currents generated from the high switching frequency of the VFD's power devices and the harmonics associated with them. These high frequency leakage currents are not at the base frequency of the drive output which is normally 50 Hz or 60 Hz. These high frequency leakage currents, typically greater than 4 kHz, may cause the GFCI to trip because the GFCI is designed to work with 50 Hz or 60 Hz frequency inputs, not this higher value.

The high switching frequency of the VFD's power devices induce more capacitive-coupled currents, since a capacitor approximates a short circuit at high frequencies. This creates common-mode noise, referred to as leakage current, which travels through ground and can cause the GFCI to trip. The path to ground is made through the motor bearings or auxiliary equipment bearings.

In addition to the high switching frequency of the drive, there can be many other contributing factors which cause the GFCI to trip. Some drives have built-in filters which couple additional leakage current to earth ground. Other drives use external filters and replacing them with a low leakage filter may help.

One way to help determine if the GFCI tripping is occurring from the input filter or the VFD output is to remove either the input filter or the motor and observe if the GFCI still trips. For example, if the input filter is easily removed and doing so

prevents the GFCI from tripping, the source of the leakage currents tripping the GFCI was largely from the input filter.

Another method is to disconnect the motor. If doing so prevents the GFCI from tripping the contributing source of leakage current is most likely from the output stage of the VFD. However, most often than not, the GFCI is tripping from a combination of the two and improvements on both the input and output will help.

Long motor power cables can also create noise spikes. These long leads add more capacitance which increases noise spikes from the fast switching power devices of the VFD. Use a VFD rated cable with the shortest leads possible when connecting the motor power cables. A choke on the VFD's motor outputs may help reduce noise spikes.

In addition, ensure that motor cables are properly shielded, sized, routed, terminated, and grounded at both the motor and drive.

KB's GFCI Solution

KB's engineering team has studied VFDs powered from a variety of GFCI devices. A solution has been created which considers all contributing factors to get a best-case scenario that successfully works with most GFCIs.

KB investigated switching frequencies and developed custom switching frequency algorithms to reduce audible noise and leakage currents. High frequency noise spikes and ringing were reduced by modifying our proprietary power circuits for optimal results. In addition, output chokes, low leakage filters, and shielded cable were introduced, if needed, to find a GFCI solution.

Conclusion

KB has had great success providing VFDs that work with GFCIs for numerous original equipment manufacturers (OEMs). KB offers a full range of motor controls (shown in Figure-3) which can be customized to work with GFCIs. Let KB Electronics provide a solution for you.



Figure-3: VFDs Available from KB Electronics

Unboxing & Installation of your Quadrel Labeling Systems Machine

This section of your manual is aimed towards making the transition from Shipping Crate to Assembly line less Dramatic. If you have scheduled an install with one of our Professional Technicians the set-up of your machine will be a breeze. If not your manual as all of the information needed to get you going. In this section there may be some equipment shown that does not apply to the machine you purchased.

NOTE This is general instruction for all equipment (your equipment may vary slightly).

Let's get started...

First things first, check your crate/box/machine for damage. If there is damage please note the exception and contact Quadrel immediately. Any extra boxes or pallets will be either in your crate or tethered to the crate or pallet. Once you have inspected your shipment you can open the crate. Check packing slip Bill of lading against boxes received. Notify Quadrel of any discrepancies.



Carefully remove all banding on the legs, misc. boxes and assemblies in the crate or on the pallet. If your machine is



wrapped in bubble wrap or plastic wrap go ahead and carefully cut and remove that as well. Ensure you are wearing the appropriate safety gear when removing your machine from the crate.



Ensure all plastic wrap is removed from the assembly you are removing the support from before removing the support.

Remove the supports under your labeling heads, wrap station, top trap, HMI, Pacing wheel or belt. See images for various supported assemblies.



Most assemblies supported have a tool-less vertical adjustment using a knob or hand wheel.

The hand wheel may be wrapped to the assembly to prevent damage.

Remove the hand wheel from the wrap, then fasten the hand wheel to the square end on the lead screw using a 3/32 "L" handle Allen wrench.

Turn the handle/knob to raise the assembly this will take the weight off the supports so you can remove them.

Top Trap Support (top) Labeler Head Support (bottom) Plastic wrapped hand wheel (right)

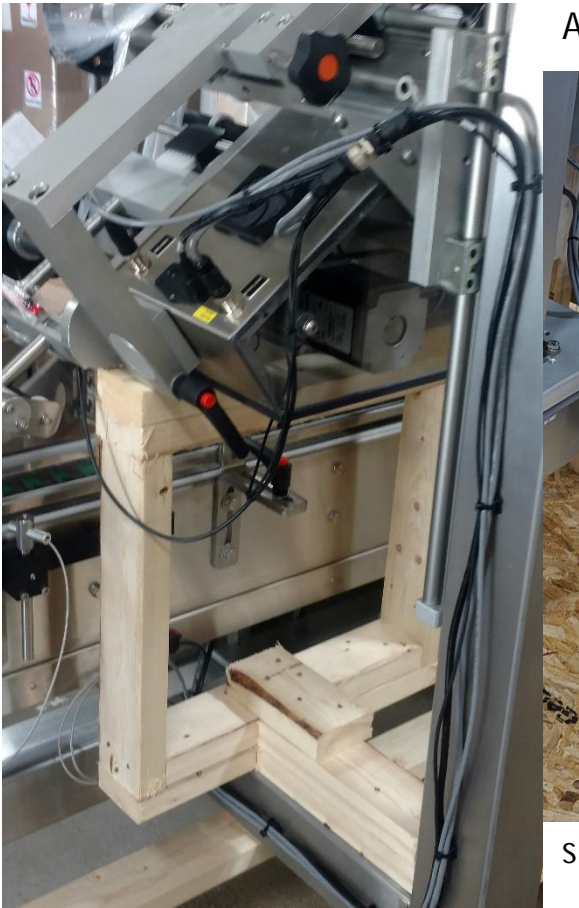

All top and bottom labeling heads will be supported

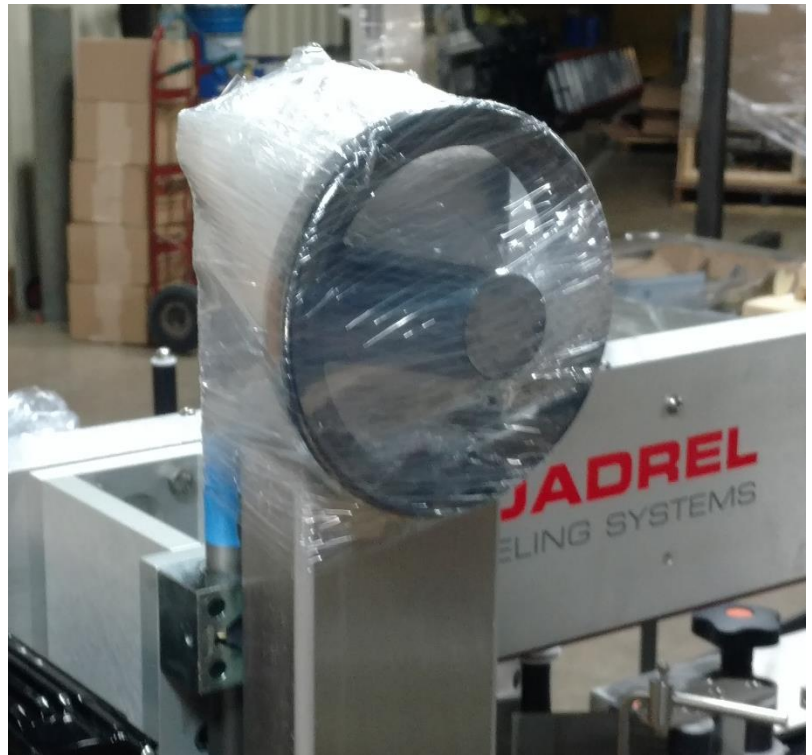

similar to the image shown on the left.

Wrap stations will have supports similar to the image to the right. These supports do not require moving the assembly.

Pacing belt assembly supports can be removed without raising the assembly.

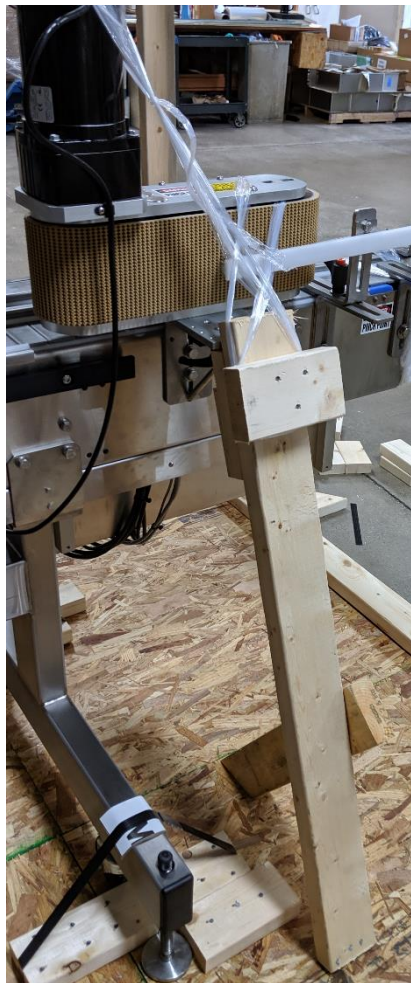

Pacing wheels supported as shown

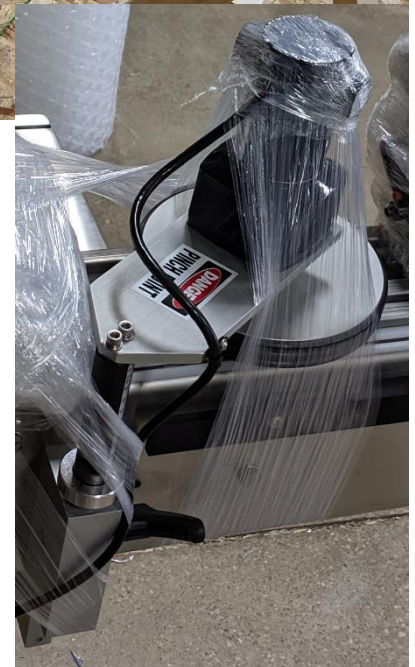



Often the head support will be moved in shipping or moved to be supported. When you are setting up your machine refer to your set up sheet in this manual. There are scales on the side of the assembly to line the carriage up to (as shown in the Image to the left and below).

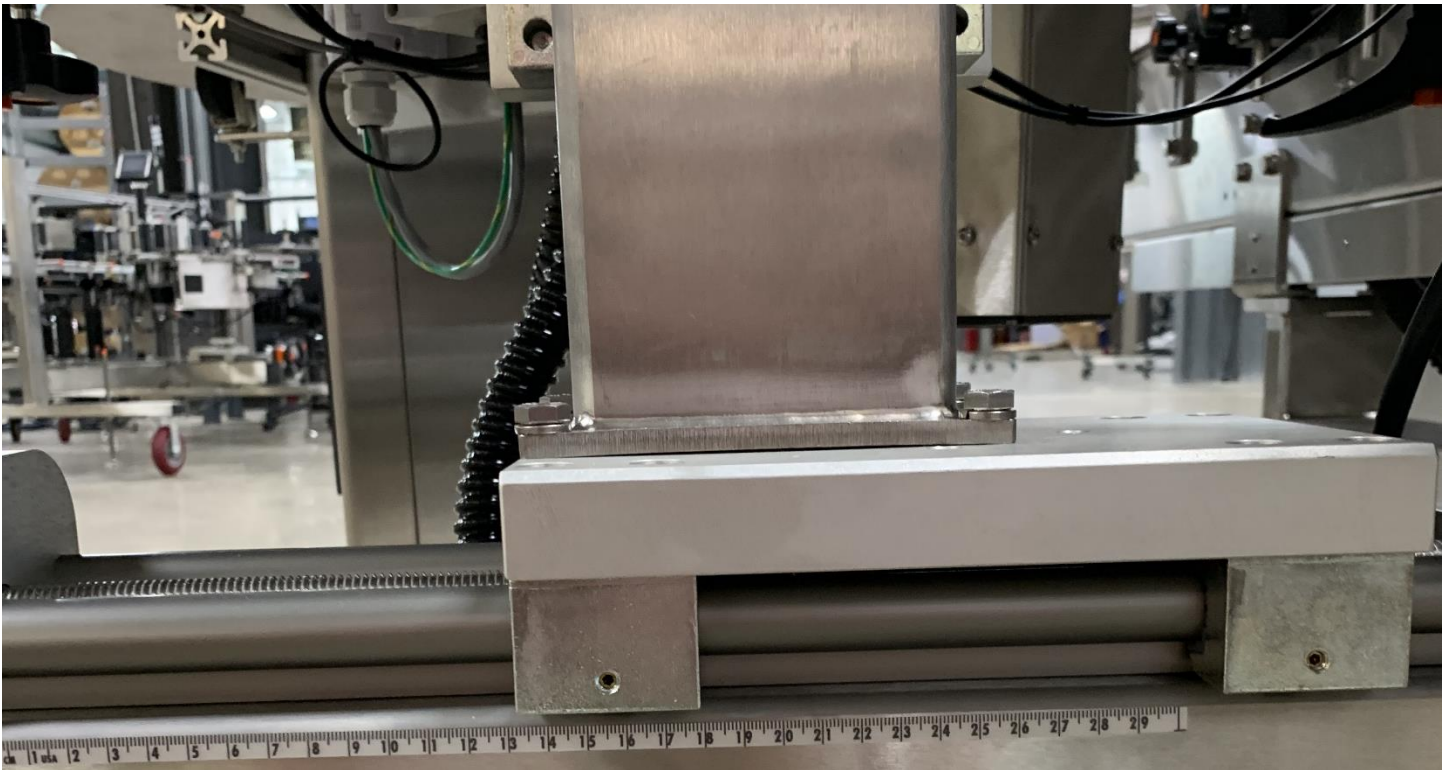

Peel plates with or without the rods may be removed from the labeling head to move the head all the way in during shipping.

All assemblies removed will be bubble wrapped then plastic wrapped to the machine (as shown in image on the right) or in box on the pallet the machine is on (as shown in image below).



Mount the peel plate assembly using a 5/16 L handle Allen wrench (as shown in image on the left). The bolts are located in the assembly. You simply put the wrench in the quick change access holes to loosen or tighten the assembly.

NOTE When you are setting up your machine make sure the peel plate assembly is perpendicular to the conveyor. When the peel plate assembly is on the rods there is a small amount of play allowing you to make small adjustments to the assembly.

If you have the peel plate rods removed with the peel plate assembly and the label detect assembly (as shown below).

All assemblies removed will be bubble wrapped then plastic wrapped to the machine or in box on the pallet the machine is on.



First back the head out all the way. Locate your peel plate assembly and slide it into the holes in the drive roll assembly (as shown on the left of the image above). Make sure you take the bolts out of the end of the rods before putting them into the drive roll assembly.



Fasten the assembly to the drive roll with the bolts supplied using a 5/16 L handle Allen wrench. Make sure you have the lock washers on the bolts.

NOTE When you are setting up your machine make sure the peel plate assembly is perpendicular to the conveyor. When the peel plate assembly is on the rods there is a small amount of play allowing you to make small adjustments to the assembly.

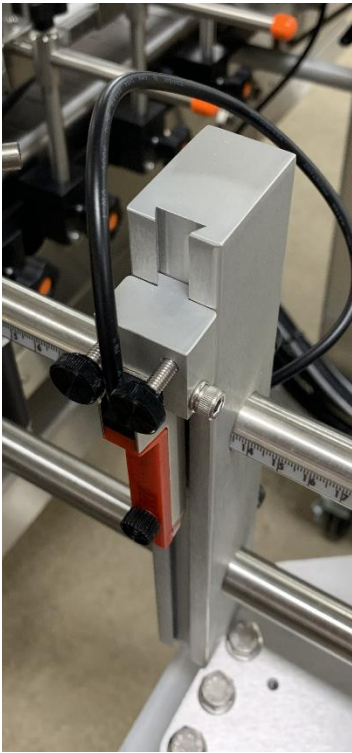

When the peel plate rods are removed the label detect sensor is removed with it (shown in image to the left). The sensor is locked into place so it won't move or need adjusted. All that will need done is simply reconnect the sensor to the zip port. To re-connect the sensor first locate the zip port (as shown in image on the right). The zip port is located under the head on the chassis or mounting plate. Take the cable coming from the sensor, route it neatly under the head, and screw it into the zip port where it says "label detect".



Some machines may have the unwind flange (shown in image to the right) removed to protect the flange during shipping do to the width of the machine.

All assemblies removed will be bubble wrapped then plastic wrapped to the machine or in box on the pallet the machine is on.

First, slide the unwind flange (with the collar facing towards you as shown in image to the right) over the unwind shaft. Make sure the top of the flange is 1 ¼ inches off the side plate.

Then, lock into place by tightening the collar with a 5/32 L handle Allen wrench.

Slide the quick lock collar over the shaft by lining the set screw up with the flat. The collar locks into place by rotating the collar 90 degrees.



Some machines may have the rewind flange (shown in image to the right) removed to protect the flange during shipping do to the width of the machine.

All assemblies removed will be bubble wrapped then plastic wrapped to the machine or in box on the pallet the machine is on.

First, slide the rewind flange (with the collar facing away from you as shown in image to the right) over the rewind hub make sure the flange just above the rubber bumper roughly 1/2 inch off the side plate.

Then, lock into place by tightening the collar with a 5/32 L handle Allen wrench.



Rails and transfers on the infeed and outfeed may be removed for shipping purposes. They will be wrapped in bubble wrap and wrapped to the machine. Carefully remove wrap and place in position as shown lock into place by tightening the knobs or ratchet handles.

NOTE Your machine may have a different rail system either adjustment is tool-less and fastened by a knob of ratchet handle.



End transfers will be wrapped in bubble wrap and plastic wrap. They will be located in a box on the pallet with your machine or wrapped to the machine itself.

Fasten the end transfer plate to the machine using a 5/32 L handle Allen wrench and the supplied 10-32 socket head screws. Ensure the transfer plate is both level with the conveyor and DOES NOT hit the conveyor chain.

Stack lamps are usually placed at the highest point of the machine and for that reason they are either removed or rotated 180 degrees. The stack lamp will be wrapped in bubble wrap and wrapped to the machine.

If the stack lamp is rotated then all you need to do is remove one of the bolts, rotate the stack lamp and put the screw back in. We use various screws on stack lamps you will need one of the following tools for the job.

- 3/32 L handle Allen wrench
- 1/8 L handle Allen wrench
- 5/32 L handle Allen wrench
- 3/16 L handle Allen wrench
- 1/2 open end wrench



HMI over head touch screen displays may be laid flat across the top of the enclosure wrapped in bubble wrap and plastic wrap.

Carefully remove the plastic wrap and bubble wrap.

Rotate the HMI 90 degrees and slide into the mount on the enclosure.

Fasten the pole in place by tightening the 2 set screws on the mount with a 6MM L handle Allen wrench.



The HMI may be enclosed in a wooden support off the enclosure to hold it in place during shipping.

If HMI is located remotely off the enclosure it will still be supported during shipping.

If so, carefully remove the supports and you are done.

All printers, printer controllers and lasers are removed from the machine when shipping and placed in the manufacturer's box. The cabling will remain on the machine for ease of installation.

The printer is mounted to the printer mount with 1 ¼-20 ratchet handle. Make sure you line up the indents in the plates with the brass nut on the threaded rod. Then slide the ratchet handle through the center of all of the blocks and tighten. Plug in the cables and you are done.



Table top printers with printer tables will ship in separate boxes or pallets (as shown to the left) the printer will be disconnected and placed in the manufacturer's box. The table will either get banded to the pallet with the machine or a separate pallet tethered to the machine pallet. Printer tables may be connected to the machine via weldment or a remote from machine. If you have a weldment connected table, refer to the lay out drawing of your machine in this manual. Fasten the weldment to the frame of the conveyor using the supplied hardware and an open end wrench. If the table is remote then move into the desired position referring to your layout drawing. Remove the printer from the box set on the table and plug in the pre-wired connectors.



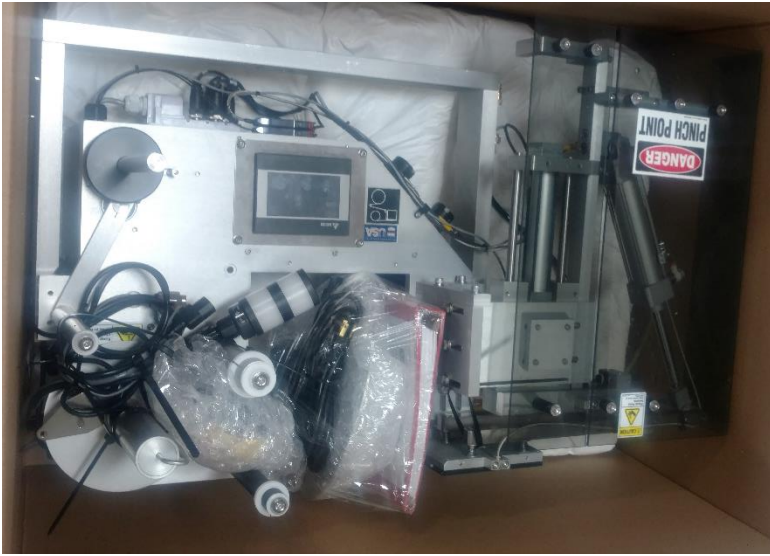

Print and apply printers will be removed from the labeling head as well and placed in the manufacturer's box. Your labeling head will likely ship in its own boxes with a few of the assemblies or flanges removed. Occasionally your head on a stand will ship on a framed pallet which will require little work to get started.

The unwind flange is installed like the previous one discussed previously.

Remove the printer from the box and place it into the opening of the labeling head (as shown in image to the right). Fasten the printer to the side plate of the labeling head using the supplied (5) 10-32 socket head screws and a 5/32 L handle Allen wrench. Then, plug the printer in.

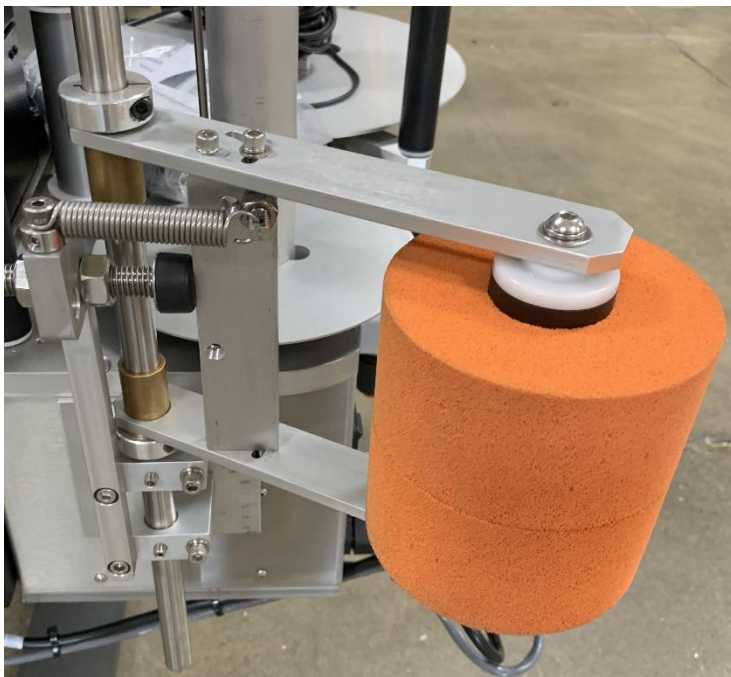

The corner wrap modules will be removed for shipping purposes. They will be wrapped in bubble wrap, plastic wrap, and placed into the box with the labeler.

Take out of the box, carefully remove the wrapping.

Then mount to the labeling head with (4) 1/4-20 bolts using a 3/16 L handle Allen wrench.

To prevent kinking of the air lines during shipping on our q34 print and apply labeling heads. All lines are pulled and labeled to the corresponding color. The hoses are color coded and marked. Simply plug in hose into the matching color (as shown in image to the right).

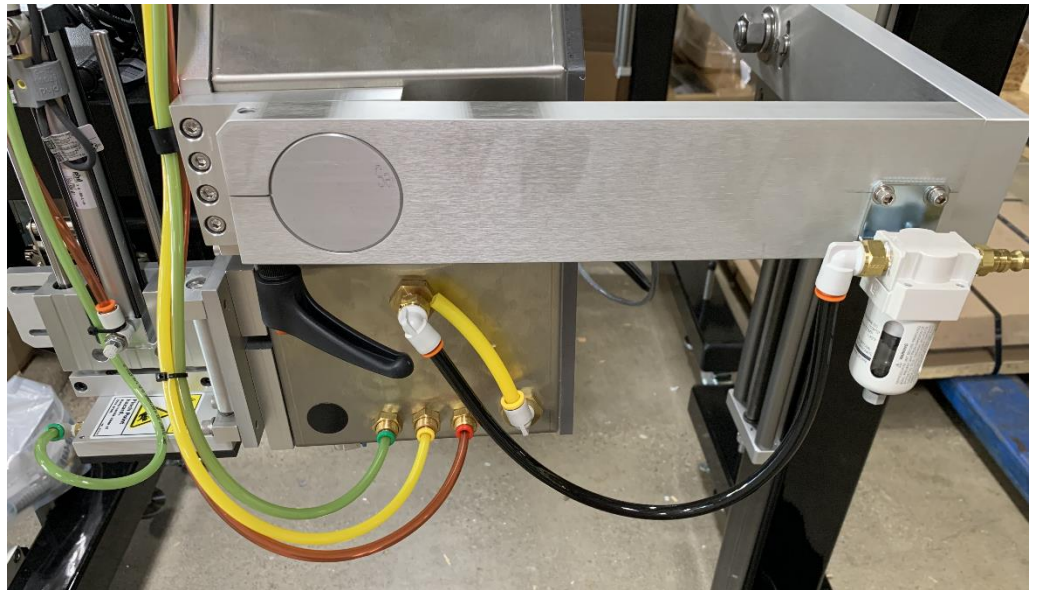

Rotary accumulation tables are banded to a pallet and wrapped.

These tables usually operate independently to the machine.

Carefully un-band and unwrap the table.

Line it up to the transfer plate on the conveyor.

Level the table using the leveling pads.

Plus in and adjust speed through the control box.



Sleeving applicators are typically on a stand and will ship on a pallet. They will be banded have many supports and be wrapped to protect the machine during the shipping process.

Carefully remove the banding and wrapping.

Raise the head and remove the supports.

The pallet will contain boxes with. Misc assemblies and or parts (ie mandrels).



Below is an image of the mandrel. The mandrel is the most precise and important part of the sleeve system. Always handle the mandrel extremely carefully.



Your mandrel will be located on the machine pallet tethered to the machine. It will be wrapped and in a box or tube (as shown below).

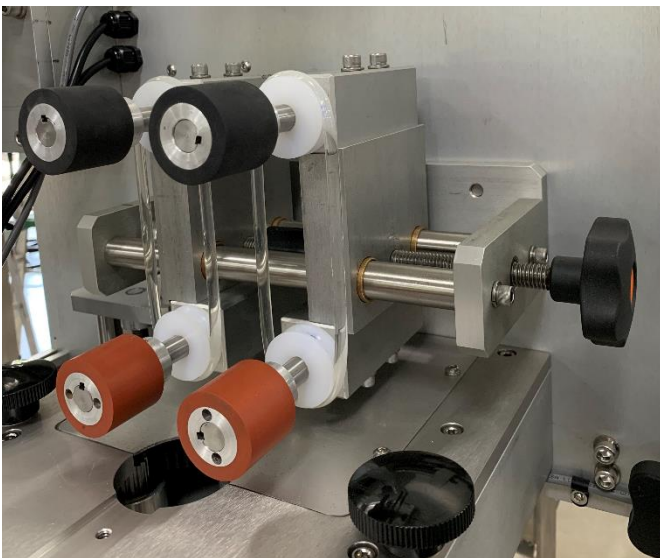

Carefully remove the mandrel from the packaging.

Rotate the black handle to move the throw down rollers apart far enough to slide the mandrel in.

Ensure each roller is between 2 bearings, the fin on the top is between the sensor, and the cutter blades are in line with the cut in the mandrel.

Rotate the black handle to move the throw down rollers closer to the mandrel pinching it in the middle. **DO NOT OVER TIGHTEN THE THROW**

DOWN ROLLERS INTO THE MANDREL. They need to be just tight enough that the bearing spins and a label feeds through.

Proline machines with guarding will either be left on the machine and have wooden supports to protect during shipping or the guards are removed and placed on a pallet.

If the guarding has supports carefully remove the supports from the guarding.

If the guarding is removed from the machine each panel will be labeled and the machine will be labeled to make it easy to figure out which door goes where.



The doors are fastened to the frame of the machine with the supplied hardware.

Line the hinges up to the holes on the frame put the bolt through.

Tighten a nut on the opposite end with the supplied flat and lock washer.





During shipment if the conveyor gets skewed you may need to re-square it. First check the conveyor with a square to verify (as shown in images below). If the conveyor needs adjusted, adjust the conveyor by slightly loosening the 4 bolts connecting the 2 sections on conveyor you would like to adjust (as shown in image to left).

Make your adjustments and check the top and side with a square. Placing a square across the top will check the squareness vertically. Placing a square along the side will check squareness horizontally.



When the conveyor is square tighten the bolts and you are all set.

When shipping a proline with an extended boom the dual swiveling elbows in the center of the boom get flipped 180 degrees to allow the machine to have enough over head clearance to ship safely (shown in image below).



Below are the instructions to flip the elbows to the correct configuration (as shown in image below)



Ensure the overhead controls are safely supported by a tow motor or at least 2 people so it does not fall when disconnecting the elbows.

Locate the 2 screws on the top and 2 screw on the bottom holding the prospective covers on.



With a t25 torx bit screw driver, loosen the 2 bolts holding the cover on the top and bottom.

With the cover off you can now access the 4 bolts holding each of the tubes in place.

Ensure the overhead enclosure is supported enough to hold for a few minutes while you loosen the bolts and flip the elbow.

Using a 6MM L handle Allen wrench loosen the 4 bolts on the top and bottom tube.



Quickly pull the tubes out and rotate the elbow as shown below.



BEFORE



AFTER

Slide the tubes in. the overhead enclosures elevation is going to change when flipping the elbows if you have it supported via tow motor you will have to raise it.

Fasten the 8 bolts with a 6MM L handle Allen wrench.

Fasten the covers to the top and bottom elbow using a T25 torx bit screw driver.



To the left shows the correct orientation of the dual elbow boom for the overhead enclosure.

If you have any questions please give our professional technicians a call.

FAMILY GUIDE



Operator Interface Guide

ML60/125 Labeling System

SB22601_008_v001 Files

Keyence Nano PLC, Maple/Weintek Touch Screen, Applied Motion Servo

General Overview:

The HMI communicates to one PLC through a serial connection and Servo Drive through an ethernet connection. The HMI will act as the master in the system to distribute communications to each device.

Table of Contents

Opening Splash Screen.....	3
System Menu Bar.....	4
Main Screen.....	5
Recipe Menu.....	7
Labeler Menu.....	9
Labeler Service Menu.....	11
System Setup Menu.....	13
User Menu.....	15
Password Menu:.....	16
Fault Messages and Indicators:.....	17
Warning Messages.....	17
Fatal Messages.....	17

Opening Splash Screen

Upon initial power up, the terminal will initialize and display a splash screen. Once the screen and PLC boot up, the “Touch Screen to Continue” text will appear. Touch the screen to continue.



Button / Indicator Reference:

Menu Navigation Buttons: Navigation buttons will be purple circles with white outlines and icons of the target screen. Some buttons will have text below them to identify the target screen.

Standard Buttons: Standard buttons are used to turn features on/off, reset faults, clear counters, or various other functions that require operator control. Toggle buttons will typically have icons to reflect the status of the function that is being toggled while momentary buttons like Resets are circular and do not change images/colors. Many buttons and toggles may be password protected, which will appear differently if the current user does not have proper access.

Indicators: Status Indicators will be circular and will change color based on states. Mode indicators will be oval in shape and will change colors and texts based on states.

Numeric and Text Displays: Numbers or Text displays will have a light orange background with black text and be oval in shape.

Numeric and Text Inputs: If a number or text can be entered, the button will have a dark green background (typical, but colors can change) with white text. The right side of the button will have a touch icon signify that it is an entry box. All numeric entries will have the touch icon regardless of color.



System Menu Bar

Pressing the System Menu button in the Top Left corner of the screen will cause the system menus to appear as pictured below.

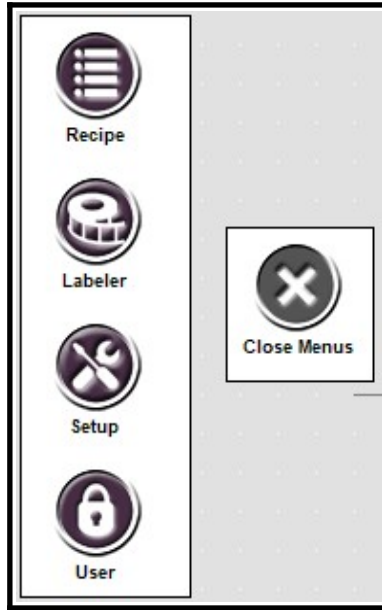



Main Screen

After touching the splash screen, the touch screen will display the Main screen. You can also get to the Main screen by pressing the Home icon (pictured left).



System Menus:

This button will expand the menu bar on the left side of the screen.

Fault/Message window:

Displays current alarms and status messages about the status of the labeling system.

The Faults Menu button can be used to display more messages or a history if needed. Pressing the Blue reset button will clear these messages if the fault was remedied.

System Start / Stop:

If a back belt is installed and enabled, it can be started and stopped using this button. The speed of the belt will be controlled by a knob on the enclosure door.



Green "START" Button: Press this button to start the back belt.



Red "STOP" Button: Press this button to stop the back belt.

Labeler Run/Stop:

The Labeler can be toggled between Run and Stop (pending fault conditions). The Run/Stop button will change colors and text based on the current status.



Green "Running" Button: This indicates the labeler is currently running and cannot be jogged. While running, the labeler will automatically apply labels to passing products. To **stop** the labeler, press this button.



Red "Stopped" Button: This indicates the labeler is currently stopped and may be jogged. While stopped, the labeler will ignore products passing by. To **run** the labeler, press this button.

Labeler Jog:

When the Labeler is stopped, the Jog button becomes available. Pressing the Jog button will cause the labeler to dispense one label (pending proper threading and label gap detection). It is important to jog labels upon threading or changing over to verify the labeler is threaded and functioning properly.



Green “Jog” Button: This indicates the labeler can be jogged. Press this button to start a jog process. This button will be grey while the labeler is jogging.



Greyed out “Jog” Button: This indicates the labeler is currently running, and may not be manually jogged.

Labeler Status Indicator:

The status indicator below the Run/Stop buttons will identify which fault state the labeler is in.

Green: Ready / OK. The labeler has no fault conditions and may operate normally.

Yellow: Warning. The labeler has a warning present (typically low on labels). The labeler may operate normally, but will require attention soon.

Red: Faulted. The labeler has a fault on it that will prevent it from dispensing labels.

Grey: Disabled. The labeler is disabled and all functions are bypassed.

Pink: Processing New Speed. When the speed ratio of the labeler is changed while running, it must temporarily pause while processing the new speed ratio.

Product Rate (Parts Per Minute):

This indicator will reflect how many parts per minute are being labeled by the system. This number will average out over a period of time and may need at least 10 products in order to start calculating a rate.

Current Recipe Description:

This display reflects the description for the currently selected recipe. Recipes are explained in the Recipe Menu.

Product Count:

This counter reflects how many Products have passed the product detect sensor while the labeler is Running.



Recipe Menu

This menu allows the user to select each labeler or recipe menus.



System Recipe:

Recipes are presets that contain parameters unique to each product. Setting Recipes for different products expedites changeover times. A total of 19 system recipes can be stored and descriptions can be changed when logged in at a Supervisor Level.

System Recipes store the following information:

Description

Labeler Parameters: Product Delay, Label Stop, Max Feed, Labeler Speed Ratio / Dispense Speed

Load Recipe:

Changing the Recipe number at the left will load the newly entered recipe to the system. Recipes can only be changed while the Labeler is stopped.

Current Recipe Description:

The description display at the top of the screen reflects the stored description for the recipe currently loaded on the system. When logged in at a Supervisor level, the change description button will appear which is used to enter a new recipe description.



Save Recipe (Supervisor Level):

The Pink Save button must be pressed to save all current values to the currently selected recipe.



Save As Recipe (Supervisor Level):

The current settings can be saved to a new target recipe. First change the Recipe to Save As number (when logged in at a supervisor level) and then press the Save As Recipe button in the bottom left. The description will automatically be copied, but will start in "Copy_" to identify it's a copied recipe.



Change Recipe Description (Supervisor Level):

This button can be used to change the current recipe's description.

1

Labeler Menu

The Labeler Menu contains the parameters and controls associated with dispensing labels.

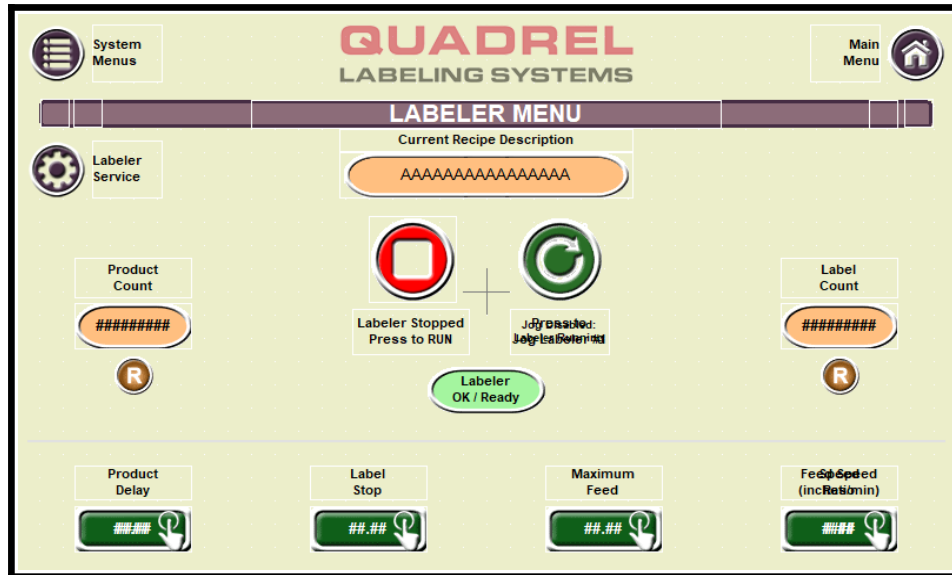

Labeler Run/Stop:

The Labeler can be toggled between Run and Stop (pending fault conditions). The Run/Stop button will change colors and text based on the current status.



Green “Running” Button: This indicates the labeler is currently running and cannot be jogged. While running, the labeler will automatically apply labels to passing products. To **stop** the labeler, press this button.



Red “Stopped” Button: This indicates the labeler is currently stopped and may be jogged. While stopped, the labeler will ignore products passing by. To **run** the labeler, press this button.

Labeler Jog:

When the Labeler is stopped, the Jog button becomes available. Pressing the Jog button will cause the labeler to dispense one label (pending proper threading and label gap detection). It is important to jog labels upon threading or changing over to verify the labeler is threaded and functioning properly.



Green “Jog” Button: This indicates the labeler can be jogged. Press this button to start a jog process. This button will be grey while the labeler is jogging.



Greyed out “Jog” Button: This indicates the labeler is currently running, and may not be manually jogged.

Labeler Status Indicator:

The status indicator below the Run/Stop buttons will identify which fault state the labeler is in.

Green: Ready / OK. The labeler has no fault conditions and may operate normally.

Yellow: Warning. The labeler has a warning present (typically low on labels). The labeler may operate normally, but will require attention soon.

Red: Faulted. The labeler has a fault on it that will prevent it from dispensing labels.

Grey: Disabled. The labeler is disabled and all functions are bypassed.

Pink: Processing New Speed. When the speed ratio of the labeler is changed while running, it must temporarily pause while processing the new speed ratio.

Product Count and Reset:

This counter reflects how many Products have passed the product detect sensor while any labeler is Running. The reset button below the counter will set this value to 0.

Label Count and Reset:

This counter reflects how many Labels have been dispensed when Jogging and Running. The reset button below the counter will set this value to 0.

Product Delay:

The Product Delay is used to center the label on the product in the left/right direction. A higher value in the Product Delay parameter will move the label towards the infeed side of the belt. When the Encoder is enabled this value is entered as inches. When the Encoder is disabled this value is entered as milliseconds.

Label Stop:

Label Stop (in inches) controls the label's stop position. Typically the label should stop with 1/8" to 1/4" sticking off of the peel plate. A higher Label Stop will result in more label off of the peel plate.

Max Feed Length:

The Max Feed Length (in inches) determines how much of the liner will advance when no label division is detected by the Label Sensor. If this value is lower than the physical length of the label, poor label stop will result. This value is typically set to a value at least 1/4" longer than the actual label length. The system also uses this distance to determine if a label is missing on the liner and warning message generation.

Labeler Speed Ratio (Encoder Enabled):

The Labeler Speed Ratio is the value that determines the actual dispensing speed of the labeler. A value of 1.00 means that the labeler will dispense the label at the speed of the back belt.

Feed Speed (Encoder Disabled):

The Feed Speed determines the dispensing speed of the Labeler when no encoder is used. This value is entered as inches per minute.



Labeler Service Menu

The Labeler Service Menu contains parameters and toggles related to the Labeler that are not typically accessed on a regular basis.

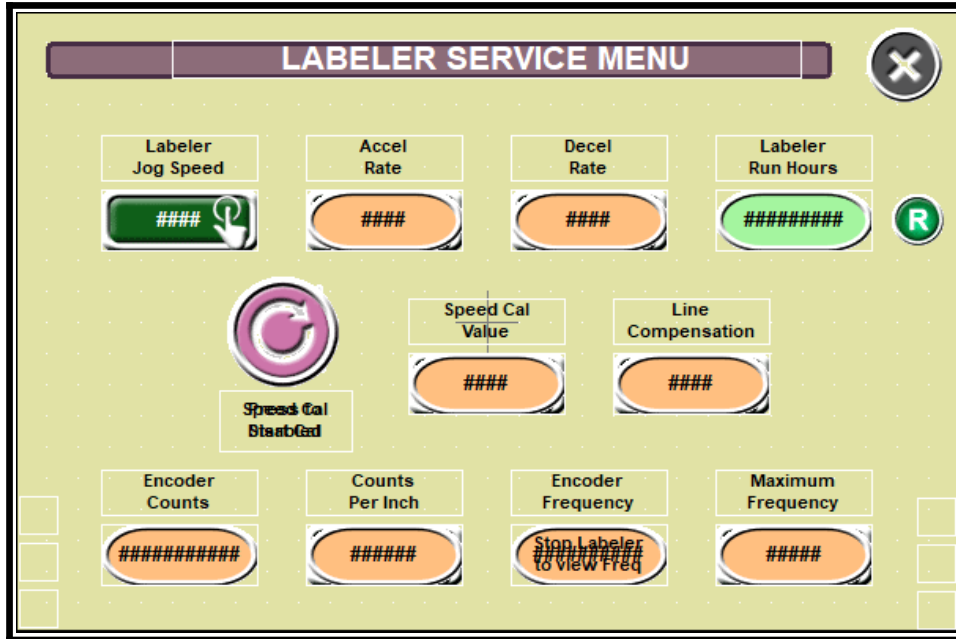

Jog Speed:

The Jog Speed determines the dispensing speed of the Labeler when manually jogged and no encoder is used. This value is entered as inches per minute.

Accel and Decel (Supervisor Level):

These are the ramp values used by the labeler drive when dispensing labels while running. A lower value results in a longer Accel or Decel rate.

Labeler Run Hours and Reset (Supervisor Level):

This counter will count the hours that the Labeler has been in the run mode while the conveyor is running. The reset button is only visible when logged in at the Supervisor Level.



Calibration: Pressing this button will put the labeler into a Calibration Mode. While active, the labeler's drive system will continue to spin until Calibration Mode is turned off.

Use Caution and make sure the drive and rewind drum are clear before turning the Calibration on!

While the Calibration is active, the Speed Cal value can be changed so the labeler's drive roll speed is equal to that of the master encoder (belt). The Labeler must be Stopped to use the Calibration mode.

Speed Cal (Supervisor Level):

The Speed Calibration number is a factor that allows the labeler to dispense at the belt speed for encoder based systems. This value is calibrated at the factory and should not require further adjustment.

Labeler Compensation (Supervisor Level):

The Compensation value adds and subtracts product delay based on the master encoder frequency. This allows the labeler to be accurate across all speed ranges. The Compensation value is set at the factory by running products at a slow speed and max speed and then altering the value until the labeler applies the labels in the same location. Note that the Compensation is based off of the Max Frequency value. Changing the Max Frequency will force the need to change the Compensation value.

Encoder Count:

This is the current encoder count as interpreted by the Labeler drive.

Encoder Counts per Inch (Quadrel Level):

The Encoder Counts per Inch value tells the labeler how many encoder pulses are counted for every inch of belt travel. This value is set at the factory and typically does not need adjustment.

Encoder Frequency:

This display will show the encoder frequency value in the labeler drive. Use this to determine the max frequency value. Note that the Labeler must be stopped to view the frequency.

Max Frequency (Supervisor Level):

The Max Frequency is calculated by running the system at max speed and adding 200 to 300 Hz to the displayed Drive Frequency. This is used for line compensation purposes.



System Setup Menu

The System Setup Menu has shortcuts to all of the system menus.

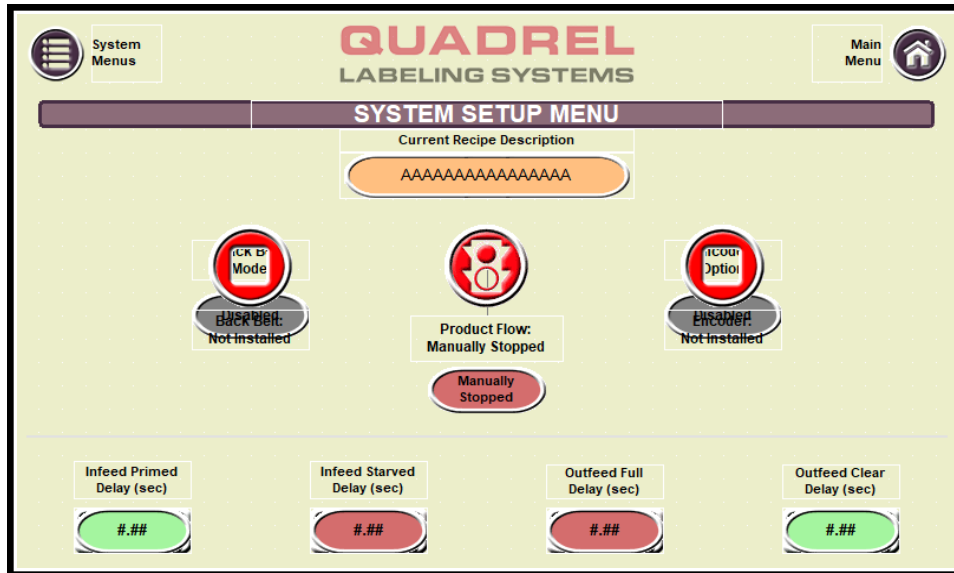

Back Belt Enable Button (Supervisor Level):

The back belt can be enabled and disabled by using the toggle button.

Green “Enabled”: This indicates the back belt is enabled. While enabled, the “Start” button will be available on the Home Screen.

Red “Disabled”: This indicates the back belt is disabled. While disabled, the “Start” button will be disabled on the Home Screen.

Encoder Option Button (Supervisor Level):

The encoder option can be enabled and disabled by using the toggle button.

Green “Enabled”: This indicates the encoder option is enabled. While enabled, the “Dispense Speed” button will be invisible on the Home Screen.

Red “Disabled”: This indicates the encoder option is disabled. While disabled, the “Dispense Speed” button will be visible on the Home Screen.

Product Flow Mode:

A dedicated "Stop Gate" output and optional sensors will function together in order to prevent products from flowing through the system when certain conditions are not met.



Green “Automatic” Button: This indicates the Stop Gate output will energize when certain conditions are met. Conditions that stop the product flow are displayed in the fault menu.



Red “Manually Stopped” Button: This indicates the Stop Gate output will remain inactive and not allow products to enter until toggled to “Automatic”.

The Product Flow stop/close when:

- The system is stopped
- The infeed sensor is not blocked by products: empty/starved.
- The outfeed sensor is blocked by products: full/backed up.
- The Product Flow button has been toggled to “Manually Stopped”

Output Option:

The Stop Gate output can be wired to a dedicated device to prevent products from entering the system or directly to the back belt drive start relay in order to start/stop the belt automatically. When controlling the belt, the existing belt start output wire must be removed.

Infeed Empty / Starved Delay (Maintenance Level):

This timer will start when the Infeed sensor does NOT see products, which results in an Empty/Starved condition. After this timer expires, the product flow will stop.

Infeed Full / Primed Delay (Maintenance Level):

This timer will start when the Infeed sensor sees products, which results in an Primed/Full condition. After this timer expires, the product flow will start.

Outfeed Clear Delay (Maintenance Level):

This timer will start when the Outfeed sensor does NOT see products, which results in an Clear/Empty condition. After this timer expires, the product flow will start.

Outfeed Full Delay (Maintenance Level):

This timer will start when the Outfeed sensor sees products, which results in an Backed Up/Full condition. After this timer expires, the product flow will stop.



User Menu

The User Menu enables alternate login levels to access protected screens and buttons.

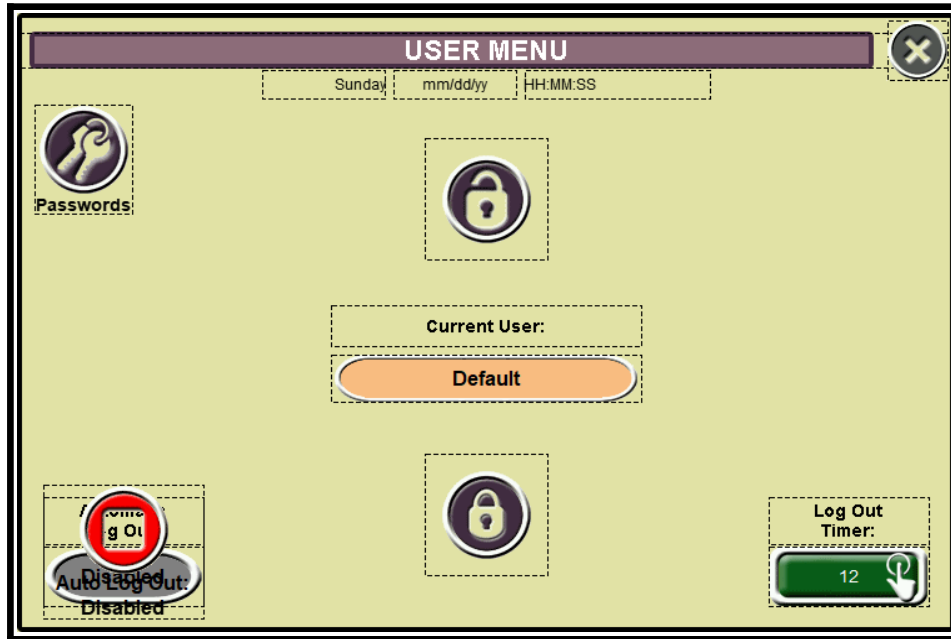

Password Input: Press this button to enter a user password. Passwords are user defined in the Password Manager Menu.



Log Out: Press this button log the current user out.



Password Manager: This will open up a security prompt before opening the password menu, where the passwords for the Maintenance and Supervisor levels are set.

Auto Log Out (Supervisor Level):

When Enabled (button will be Green), the logged in user will automatically be logged off at a set amount of time. Note that the system automatically enables the Auto Log Out feature upon startup.

Log Out Timer (Supervisor Level):

This timer (in minutes) determines the time it takes to log off a user if Auto Log Out is enabled.



Password Menu:

The Password Menu allows the creation and editing of the passwords for different security levels.

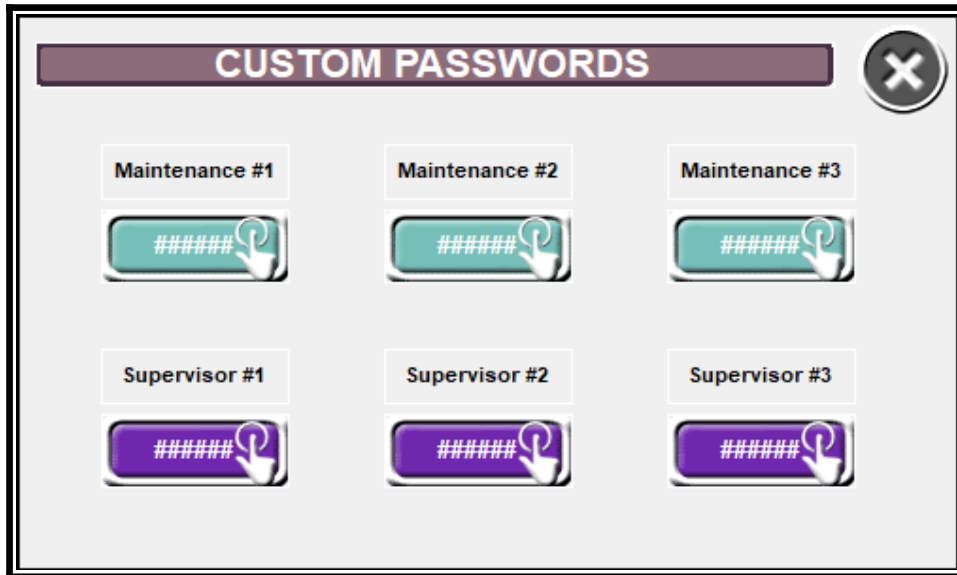

Maintenance:

There can be 3 user defined passwords for the Maintenance level. Note that there is one hard coded Maintenance Level password that cannot be viewed or changed.

Supervisor:

There can be 3 user defined passwords for the Supervisor level. Note that there is one hard coded Supervisor Level password that cannot be viewed or changed.

If a Maintenance and Supervisor password are the same, the system will log that user in at the Maintenance level.

The password(s) to open the Password Menu are stored in the HMI and cannot be modified. This will prevent any password loss in the event the PLC logic is altered.

Fault Messages and Indicators:

Green: Continuous lighted condition indicates the back belt is running when enabled or labeler running when back belt disabled. If a warning is present on the system while lamp is illuminated it will alternate with the amber lamp.

Amber: Indicates the machine has non- major fault affecting operation such as label low level. The Amber lamp will always flash.

Red & Buzzer: The red lamp will flash & buzzer will activate when any fatal fault is present.

Warning Messages: Warning messages identify a status or event that may need action soon. The machine will not stop from a warning message, but a warning may turn into a fatal fault that will stop the machine. Many warning messages will automatically clear once the problem is remedied.

Fatal Messages: Fatal messages will cause the system to stop immediately or initiate a cycle stop. Fatal faults are typically associated to events that prevent labels being applied properly, safety related faults, or other events that may prevent proper machine operation.

Messages	Cause/Solution
Warning Messages	
Labeler #X Drive Faulted / Turned Off Warning	The drive that controls the listed labeler is faulted or turned off. If pressing the reset button does not clear this message, verify that the drive is powered up.
Labeler #X Broken Web Warning	The Broken Web sensor (between the drive system and rewind) on the Labeler is active and the Labeler is Stopped. Placing the Labeler into Run will generate a Fatal Fault.
Labeler #X End of Web Warning	The End Of Web sensor (between the drive system and unwind) on the Labeler is active and the Labeler is Stopped. Placing the Labeler into Run will generate a Fatal Fault.
Labeler #X Low Label Supply	The label supply on the labeler has been determined low by the sensor fiber under the flange.
Labeler #X Program Stopped Fault	The internal program of the listed labeler drive is not executing logic. Pressing the Reset button or cycling the safety circuit may re-start the program.

Messages	Cause/Solution
Fatal Messages	
Emergency Stop Active	An Emergency Stop is active on the system. Depress each Emergency Stop to use the system.
Labeler #X Drive Faulted / Turned Off Warning	The drive that controls the listed labeler is faulted or turned off. If pressing the reset button does not clear this message, verify that the drive is powered up.
Labeler #X Broken Web Warning	The Broken Web sensor (between the drive system and rewind) on the Labeler is active and the Labeler is Stopped. Placing the Labeler into Run will generate a Fatal Fault.
Labeler #X End of Web Warning	The End Of Web sensor (between the drive system and unwind) on the Labeler is active and the Labeler is Stopped. Placing the Labeler into Run will generate a Fatal Fault.
Labeler #X Low Label Supply	The label supply on the labeler has been determined low by the sensor fiber under the flange.
Labeler #X Program Stopped Warning	The internal program of the listed labeler drive is not executing logic. Pressing the Reset button or cycling the safety circuit may re-start the program.

To set user passwords during initial setup navigate to the passwords screen, then Log in using password "7670" Once logged in users can set passwords per HMI Guide.

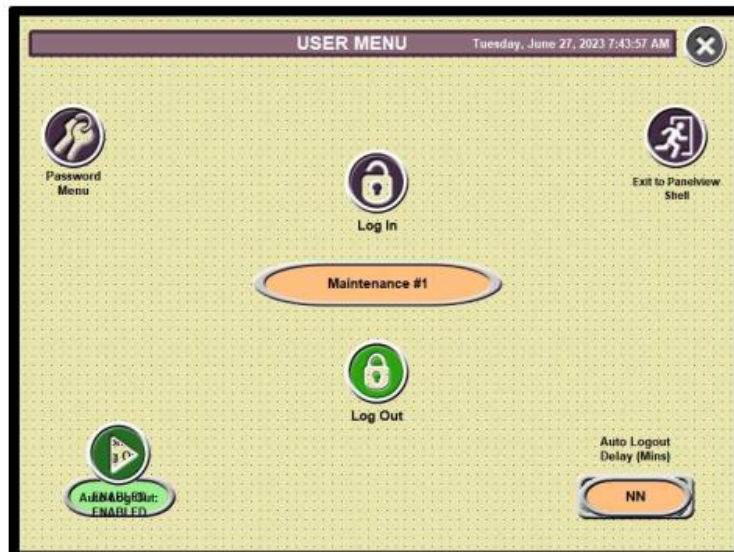
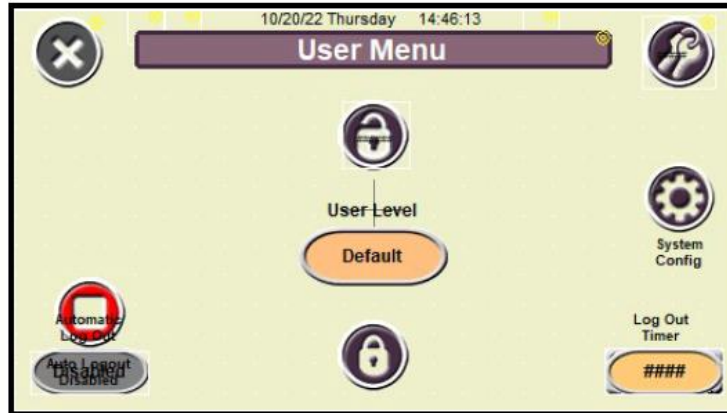

USER MENU 

Sunday mm/dd/yy HH.MM.SS

 Passwords



Current User:
Default



 Log Out
Disabled

Log Out
Timer:
12.34 

Setup sheets

QUADREL

LABELING SYSTEMS

SERIAL #: 84272-100

Labeler Menu

	LABELER 1	
	Factory	User
RECIPE	1	
PRODUCT DELAY	1.00	
LABEL STOP	0.90	
MAX FEED	6.00	
SPEED RATIO	1.00	
BELT SPEED	100	

Labeler Service Menu

	LABELER 1	
	Factory	User
ENCODER COUNTS PER INCH	745	
LABELER JOG SPEED	1000	
ACCEL RATE	100	
DECEL RATE	100	
SPEED CAL VALUE	465	
LINE COMPENSATION	1	
MAXIMUM FREQUENCY	18000	

System Setup Menu

	LABELER 1	
	Factory	User
BACK BELT	Installed	
ENCODER	Installed	
PRODUCT FLOW	Automatic	
INFEEED PRIMED DELAY	0.01	
INFEEED STARVED DELAY	0.01	
OUTFEED FULL DELAY	0.01	
OUTFEED CLEAR DELAY	0.01	

QUADREL

LABELING SYSTEMS

SERIAL #: 84272-100

Preset 1

7/8"



2 5/8"

2 1/8"

7/8"

3.25"

Distributed by
Oak Farms Dairy
Plants in Dallas, Houston,
San Antonio, Waco

Purification by reverse
osmosis and
ozonation

Source: San
Pedro Springs
San Antonio
TX 78207



1 GALLON
(3.78L)

PURIFIED

**Drinking
Water**



Nutrition Facts

Serving Size 1 cup (240ml)
Serving Per Container about 16

Amount Per Serving	
Calories 0	% Daily Value*
Total Fat 0g	0%
Sodium 0mg	0%
Total Carbohydrate 0g	0%
Sugars 0g	
Protein 0g	

*Percent Daily Values are based on a diet of other people's secrets. ©2015 Oak Farms Dairy, LLC. All rights reserved. Oak Farms Dairy, LLC, San Antonio, TX. Water is calcium and iron.

3.25"

2 5/8"

2 1/8"

WARNING



- KEEP HAND CLEAR OF MOVING PARTS. DO NOT PLACE HANDS NEAR LABELING HEAD WHEN IN OPERATION



- DO NOT OPERATE EQUIPMENT WITHOUT GUARDS OR COVERS INSTALLED



6.1 LABELING HEAD INFORMATION

6.1.1 LOADING AND UNLOADING STOCK ROLL

-  **CAUTION** To avoid injuries, you must keep the labeler stopped/paused. You can manually jog labels with the JOG button.

Look carefully at the diagram and follow the threading procedures indicated below.

You will also find the threading diagram directly on the labeling head.

- 1) Place the label stock roll on the unwind shaft. Press the roll firmly against the flange. Then slide the locking collar over the unwind shaft aligning the set screw with the shaft. Press into the roll and twist to lock the collar in place.



- 2) Pull Approximately 36-40" of stock from label stock roll.



- 3) Follow the threading diagram on the labeling head for routing the web.
- 4) Thread through the dancer to the peel plate.





- 5) Feed the label around the peel plate and under the pressure shoe if (if there is one). Feed the label up the head to the pull roll. Pull all the slack out.

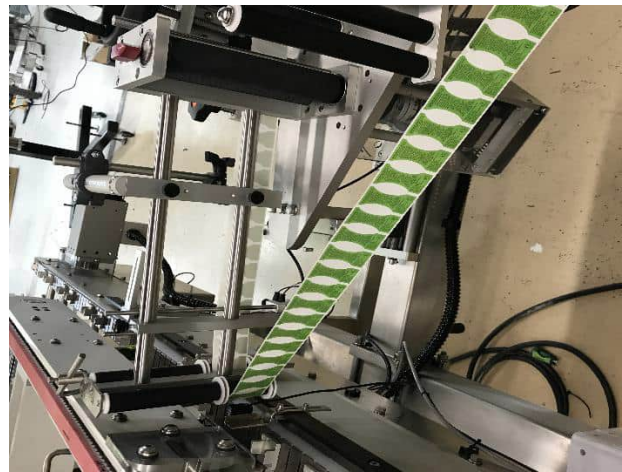
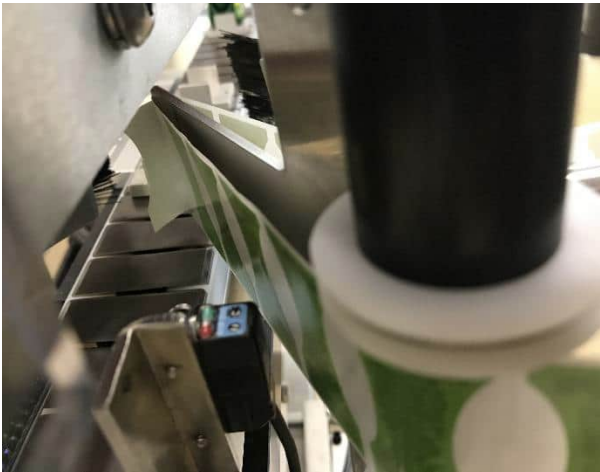

- 6) Wrap labels around the rubber roller as shown, then around the knurled roller. Make sure the knurled roller is not locked in by turning the red knob to the left or right of the red dot on the drive roll. When you have the labels completely threaded you can turn the knob to the red dot.

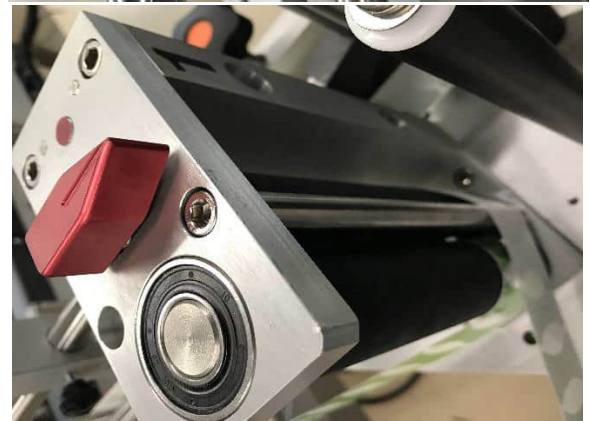
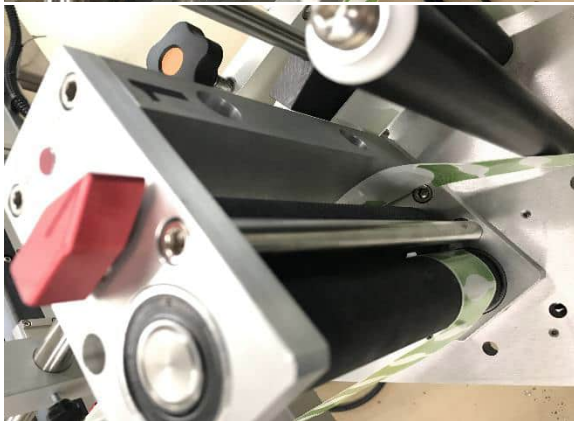
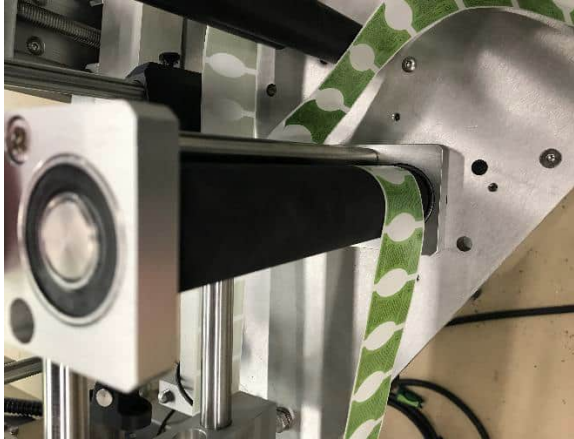

- 7) Thread the labels through the rewind dancers to the rewind shaft. Place the end of the label through the clip and rotate the rewind hub to take up the slack.



- 8) The finished product should look similar to the pictures below. Some heads are threaded differently depending on the style head you have. See threading diagrams on the head itself or the manual.

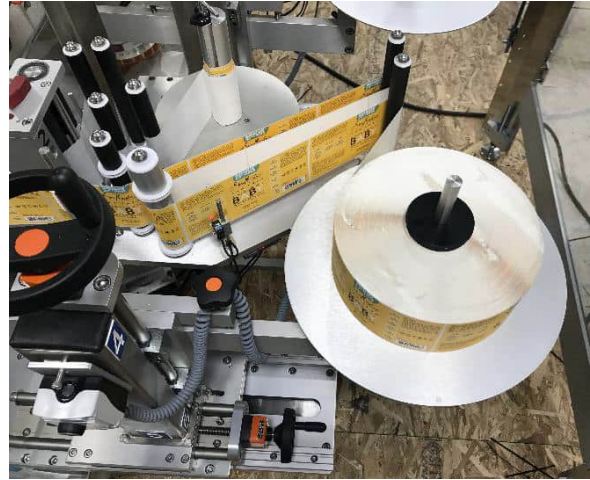

- 9) To unload the rewind loosen (counter clockwise) the “clevis” bolt on the top of the rewind hub. this will collapse the rewind and you can pull the liner off the hub.



CAUTION

There are many pinch points on a labeler. to avoid injury read and understand the owner’s manual before operating.

6.1.2 THREADING DIAGRAMS

Here are the following threading diagrams for our standard labeling heads.

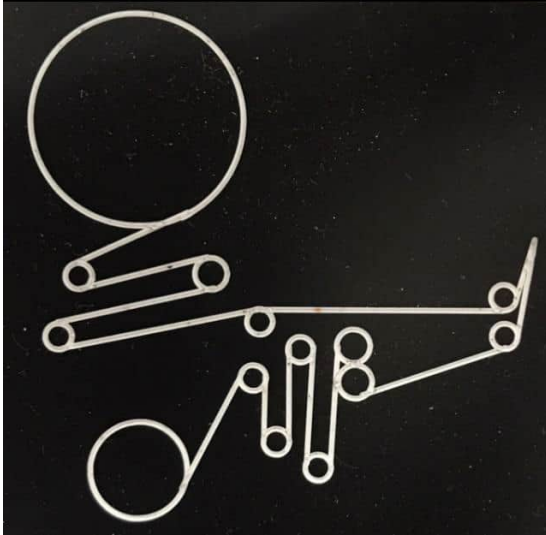

Q120/Q125/Q115/Q110

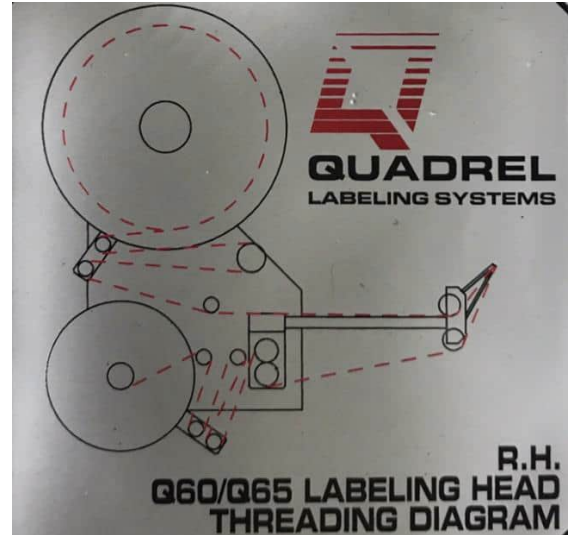

Q60/Q65

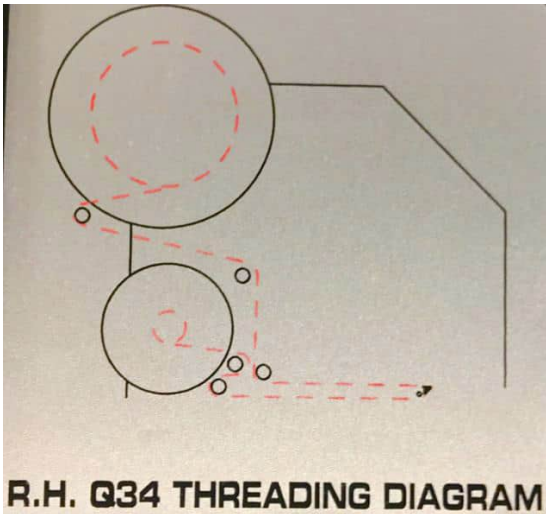

Q34

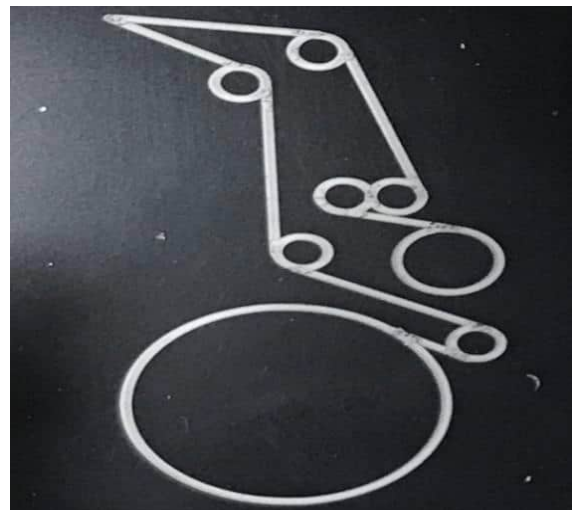

E100

6.1.3 LABELER ADJUSTMENTS

The vertical adjustment is to position the label on the container at different heights. It's practical if you have different size labels and/or containers. To adjust the height you simply rotate the handwheel at the top of the labeler counter clockwise to go down and clockwise to go up.



Horizontal adjustments are made the same way except you rotate the hand wheel under the labeler. Rotating the hand wheel counter clockwise will move the labeler in and rotating clockwise will move the labeler out.



To adjust the angle of the labeling head you first need to loosen the large $\frac{3}{4}$ -10 nut with a $1\frac{1}{4}$ "wrench and the $\frac{5}{16}$ -18 hex head bolt. The angular adjustment is very important to increase the repeatability of the process. A good adjustment is when the exit of the label is tangent with the surface of the application.



CAUTION

DO NOT remove the nut & bolt.



Now to adjust the tilt of the labeling head by tightening and loosening the jack screws.



Rotate adjustment is achieved by loosening the 2 ratchet handles under the labeling head. There is a jack screw holding the labeling head in place, but still use caution when loosening the ratchet handles the labeling head can rotate

freely when loose. This is a fine adjustment that increases the parallelism of the label to the shape of the container.



CAUTION

When loosening the labeling head, the head may rotate freely. Keep positive pressure against the head to prevent the head from rotating on its own.

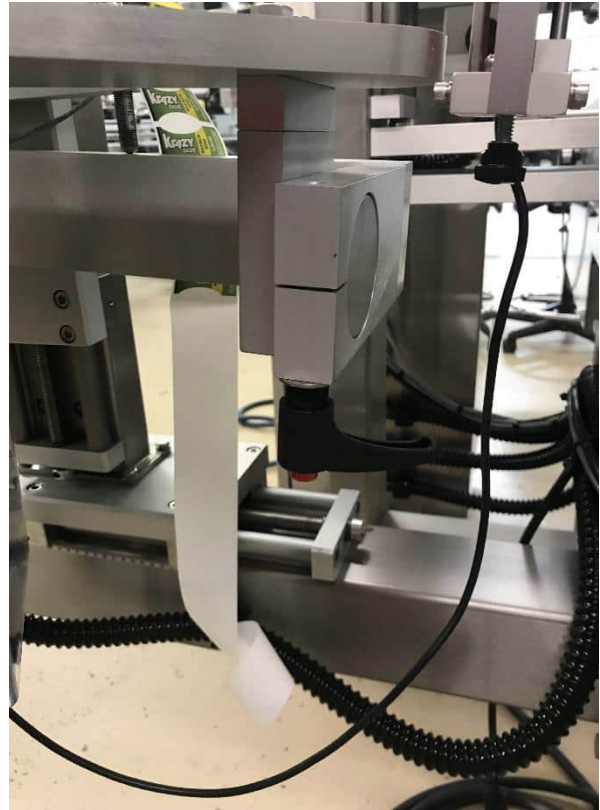



QUADREL LABELING SYSTEMS

Q125

LABELING HEAD

GENERAL DESCRIPTION

- The Q125 has been developed as a heavy duty automatic labeling head system for integration into high speed, high rate production environments. The labeling head can be configured for either wrap or wipe on applications. The Q125 uses a servo drive and motor system that can be used independently or in conjunction with a PLC. All settings are controlled from a touch screen interface for easy setup and adjustments. In addition, a built in system of fault logic can easily interface with a host of optional sensors.

PRINCIPLE OF FUNCTION

- The Q125 labeling head applies pressure sensitive labels onto moving products. Various principles are involved to achieve accurate label application. In general, a labeling system integrates three (3) basic functions:
 - **Product Handling:** The most common product handling component is the conveyor. Conveyors allow the product to transport smoothly through the labeling station. The Q125 labeler can be supplied either as a stand alone head (head on a stand) or integrated into a complete conveying/product handling system. An encoder from the product handling system must be tied into the labeler's drive.
 - **Label Application:** Usually the label is "tacked" directly to the product during the label dispensing cycle. Secondary label applicators such as brushes, roller or wrap belts are used to finish the label application and to ensure good adhesion.
 - **Label Dispensing:** The Q125 utilizes two movement types to dispense labels. The first movement is a fixed speed, "jog" movement that is used during setup purposes. Jogging labels verifies proper label threading and labeler operation prior applying labels to products. The second movement is a synchronized "run" movement that is used to apply labels on passing products. The labeler's drive system will synchronize speed with the product handling system from an encoder. This eliminates the need to change settings based on system speed and allows for accurate and repeatable labeling.

SEQUENCE OF OPERATION:

- The electrical and mechanical operating sequence described below is intended only to acquaint the operator with the operation of the label dispensing head and its related control circuitry.

- The Jog function is used for manual set-up of label dispensing. Under proper conditions, a jog sequence will dispense one label. Labels must be threaded properly and the labeler stopped (indicated on the touch screen) before Jogging labels.

- The Jog cycle is described in the following manner:
 1. After verifying that labels are threaded properly and the labeler is stopped, a jog button (physical green button near the labeler or a button on the touch screen) must be pressed.
 2. The labeler will start dispensing labels at a fixed speed.
 3. The labeler's drive will monitor a label gap sensor input before finishing a dispensing cycle.
 4. Once the label's gap is detected by the sensor, the labeler will continue dispensing the label for a length defined by the "Label Stop" parameter on the touch screen. This distance is entered as inches.
 5. After the Label Stop distance is reached, the Jog cycle is complete and the labeler stops dispensing labels.
 6. If no label gap is detected, the labeler will only index a maximum distance which is set by the "Max Feed" parameter on the touch screen. This distance is entered as inches.

- When the labeler is in the "Run" mode it will automatically dispense labels on products that are passing by. Labels must be threaded properly and the labeler placed in the Run mode (indicated on the touch screen) to automatically dispense labels
 1. A product activates the Product Detect sensor.
 2. The labeler drive captures the position of the product on the product handling system and starts an internal delay, which is the "Product Delay" parameter on the touch screen.
 3. The Product Delay is equal to inches, so once the product travels the Product Delay distance from the product detect sensor, a label will be dispensed.
 4. The labeler dispenses a label at the speed of the product which is multiplied by the "Speed Ratio" parameter found on the touch screen. The ratio is a multiplier, so a value of 1.0 determines the labeler will dispense at the exact speed of the conveyor.
 5. The labeler monitors the label gap sensor in the same manner of the Jog movement before finishing the dispensing cycle.

ASSEMBLY TITLE: Q125 LABELING HEAD ASSEMBLY

DRAWING NO.: NONE

GENERAL FUNCTION:

- Applies labels to the front and/or back, top/bottom of the products
- Wraps labels around cylindrical products

SET-UP AND ADJUSTMENTS:

- Tighten all loose connections and screws
- As noted in each sub-assembly

MAINTENANCE:

- Remove glue residue and labels from all rollers and idlers
- As noted in each sub-assembly

TROUBLESHOOTING:

- As noted in each sub-assembly

ASSEMBLY TITLE:

Q125 LABELING HEAD - THREADING

GENERAL FUNCTION:

- This section is used to guide the user through loading and feeding the label through the web path.

SET UP AND ADJUSTMENTS:

- Load label spool onto unwind hub. Secure unwind retainer onto hub and lock. Pull 3-4 feet of web from unwind and strip labels free of web.
- Unlock the drive roller locking handle.
- Using the threading diagram located on the labeling head, feed the web through the labeling head. Start at the unwind dancer assembly and work forward.
- Feed the web through the drive roller assembly.
- Feed the web around the rewind dancer assembly and onto the rewind hub. Wrap the web around the hub once. Lock the web in place with the rewind retaining bracket.
- Once the web has been threaded, lock down the drive roll assembly by rotating the drive roll locking arm into the locked position. (Towards the drive roller assembly)

MAINTENANCE:

- None this section.

TROUBLESHOOTING:

PROBLEM

WHAT TO DO

- Web break

- Check web path and insure web routed correctly.
- Debris causing web tear and break. Clear as needed.

- No Web Tension

- Check web path through unwind and dancer assembly.
- Check drive roller lock position.

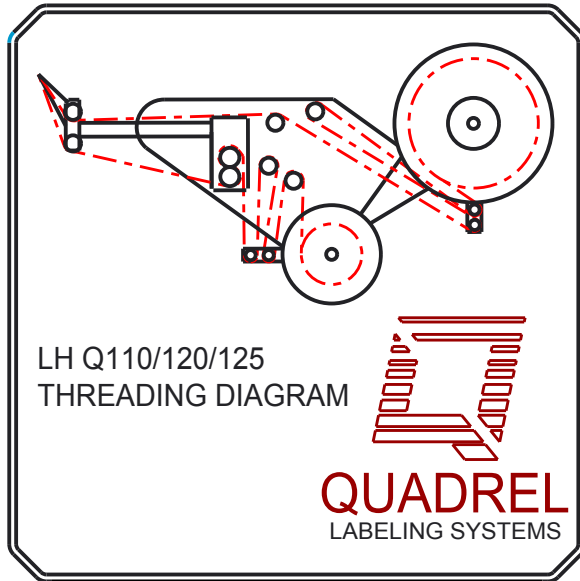

NOTES:

- 1) LABEL MATERIAL IS .003" ALUMINUM FOIL W/PERMANENT PRESSURE SENSITIVE ADHESIVE.
- 2) ALL LETTERING IS .125" HIGH EUROSTYLE 2, BOLD EXTENDED 2.
- 3) USE QUADREL STANDARD LOGO.
- 4) ALL LINES AND LETTERS ARE BLACK ON A SILVER BACKGROUND QUADREL AND (WEB PATH) ARE RED #(199c) LINES ARE DASHED LINES.
- 5) LABEL SIZE 3.0" X 3.0".

A	5-8-19	NEW DRAWING
REV	DATE	DESCRIPTION

THIS IS A PRO-ENGINEER DOCUMENT AND MAY NOT BE MODIFIED MANUALLY

UNLESS OTHERWISE SPECIFIED DIMENSIONAL TOLERANCE $X \pm .1$ $.XX \pm .01$ $.XXX \pm .005$ ANGLES $\pm 30'$ SURFACE FINISH 125 BREAK ALL EDGES .005/.015 CORNER RADIUS .010/.030	 QUADREL LABELING SYSTEMS 7670 JENTHER DRIVE MENTOR, OHIO 44060 (440) 602-4700	SCALE: DRAWING SCALE DATE: 5-8-19 DRW BY: TJS CHK BY: APPR BY:
	Q110/120/125 L.H. THREADING DIAGRAM	
MAT'L	SEE NOTES	A26222-110LH

ASSEMBLY TITLE: Q110 SIDE PLATE ASSEMBLY

DRAWING NO.: D24272-000

GENERAL FUNCTION:

- To provide a rigid mounting surface for outboard labeling components, electronic components, and system components.
- The side plate also supports the system mount

SET UP AND ADJUSTMENTS:

- None

MAINTENANCE:

- None

TROUBLESHOOTING:

- None



ITEM	QTY	PART NO.	DESCRIPTION	PARENT ITEM
1	1	00669-01	BRAKE BRUSH 2 x 7 nylon	23100SP-007LH
2	2	181062-000	BEARING, ROLL END	23100SP-007LH
3	6	181063-000	BEARING, ROLL END	23100SP-007LH
4	2	361198-000	COLLAR, GUIDE, 1" ID	23100SP-007LH
5	2	361199-000	COLLAR, GUIDE, 1-1/2 IN. ID	23100SP-007LH
6	1	791789-000	NAMEPLATE	23100SP-007LH
7	1	A20654-003	ADJ. ROD	23100SP-007LH
8	3	A20928-001	ROLLER SHAFT	23100SP-007LH
9	1	A21618-001	IDLER SHAFT	23100SP-007LH
10	1	A22291-006	ROLLER	23100SP-007LH
11	3	B20071-002	IDLER ROLLER (DANCER)	23100SP-007LH
12	1	D22800-120_REVC	SIDE PLATE, MOD.	23100SP-007LH

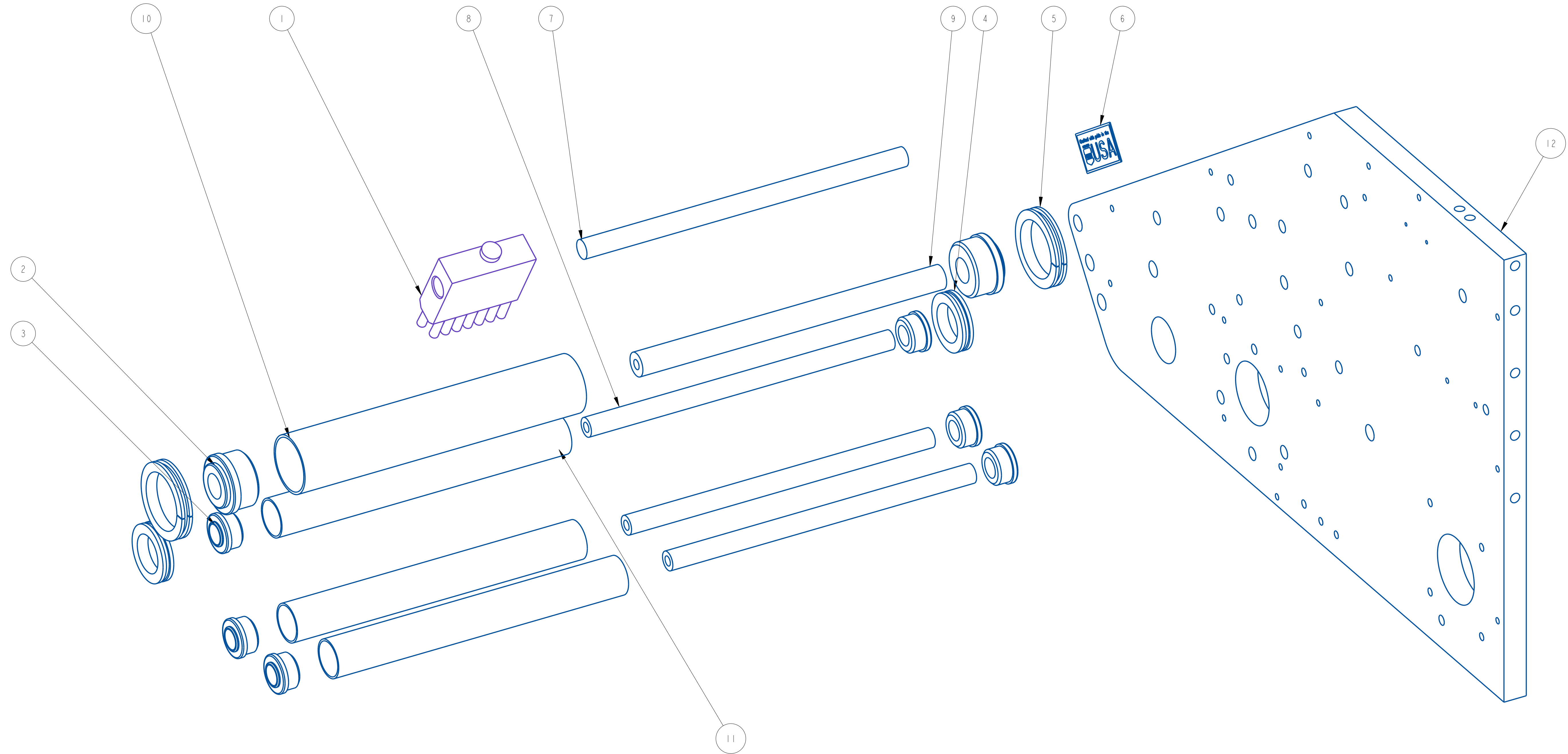

REV	DATE	DESCRIPTION	BY
B	01/29/26	REVISED DRAWINGS	SEM
A	09/08/25	NEW DRAWING	SEM

THIS IS A PRO-ENGINEER DOCUMENT AND MAY NOT BE MODIFIED MANUALLY

<small>UNLESS OTHERWISE SPECIFIED DIMENSIONAL TOLERANCE</small> X ± .1 XX ± .01 XXX ± .005 ANGLES ± .30° SURFACE FINISH 125 BREAK ALL EDGES .005/.015 CORNER RADIUS .010/.030 ALL ANGLES ARE 90°	 QUADREL LABELING SYSTEMS 7670 JENTHER DRIVE MENTOR, OHIO 44060 (440) 602-4700	SCALE: 3/4
		DATE: 09/08/25
		DRW BY: SEM
		CHK BY: 01/29/2026-SEM
SIDE PLATE ASSEMBLY, 7"		MATERIAL: 23100SP-007LH

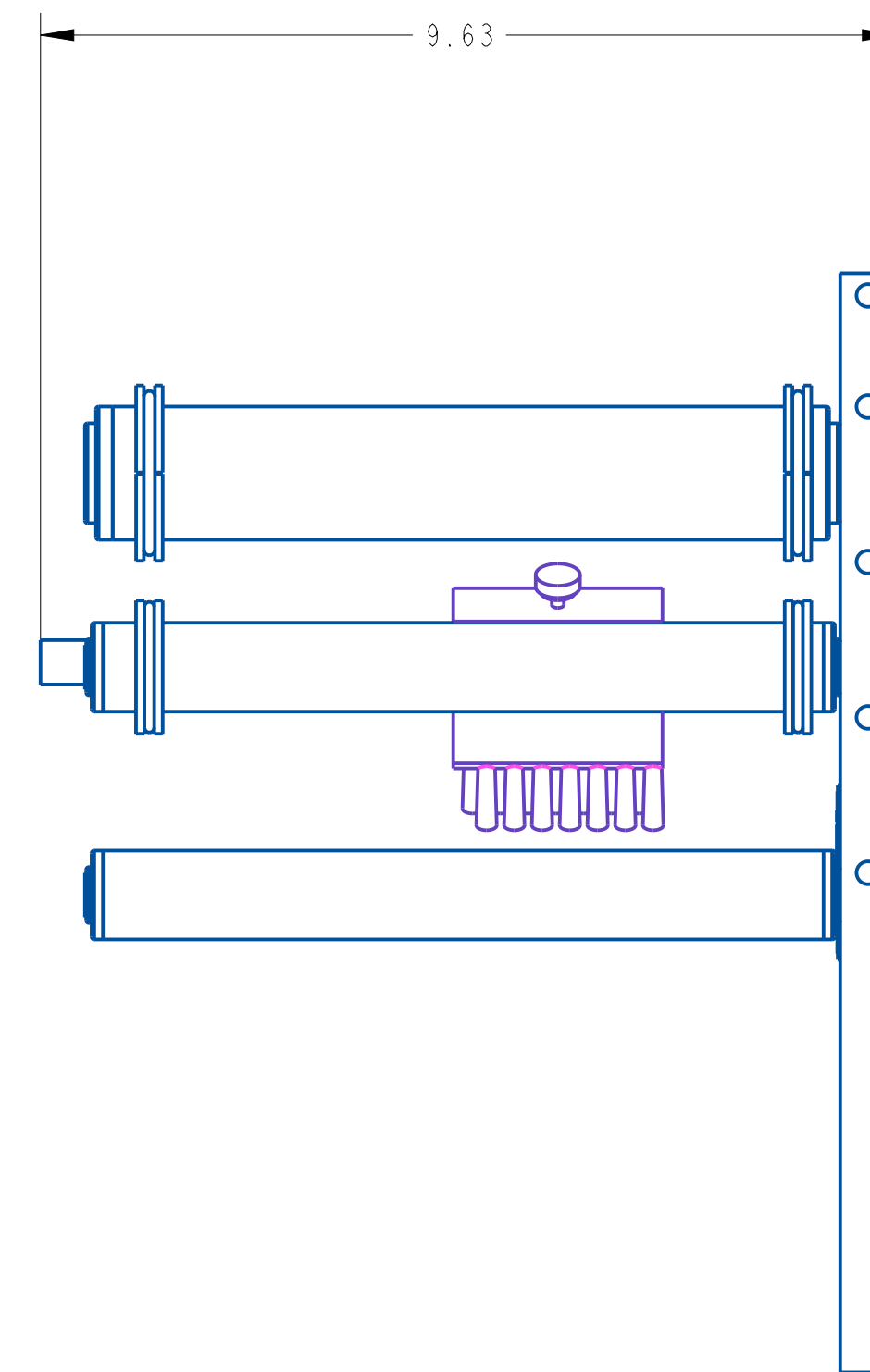
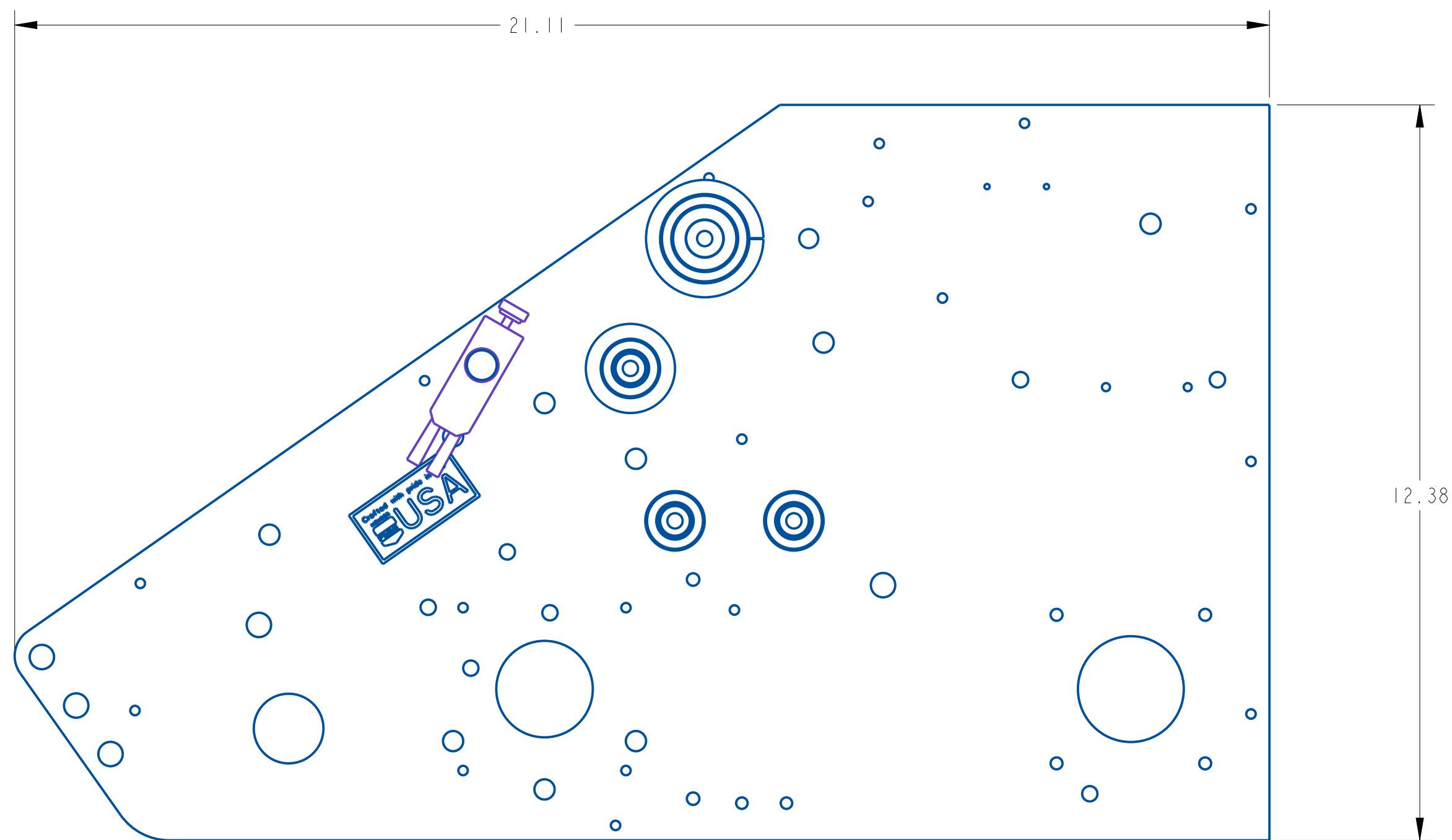
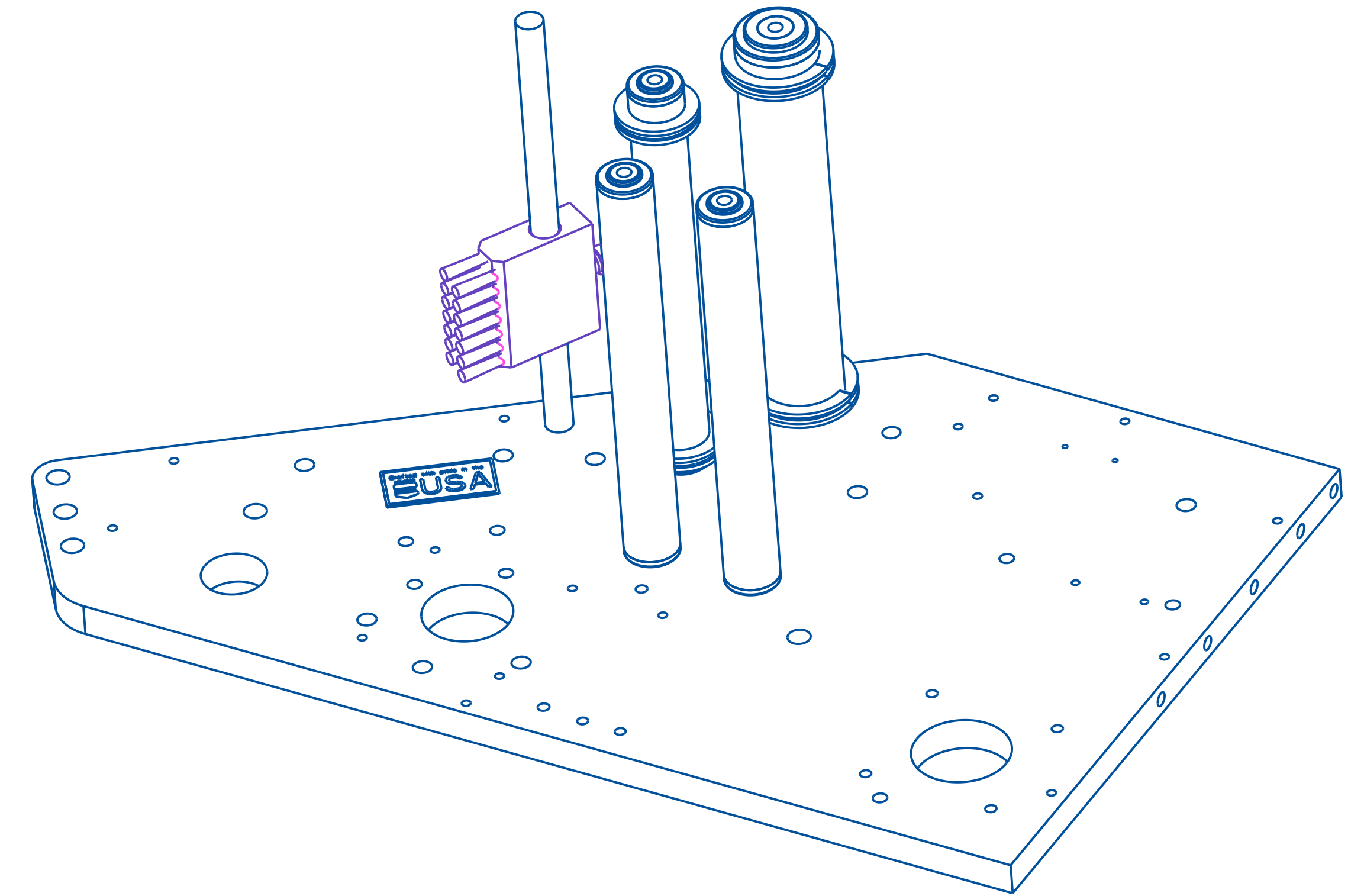
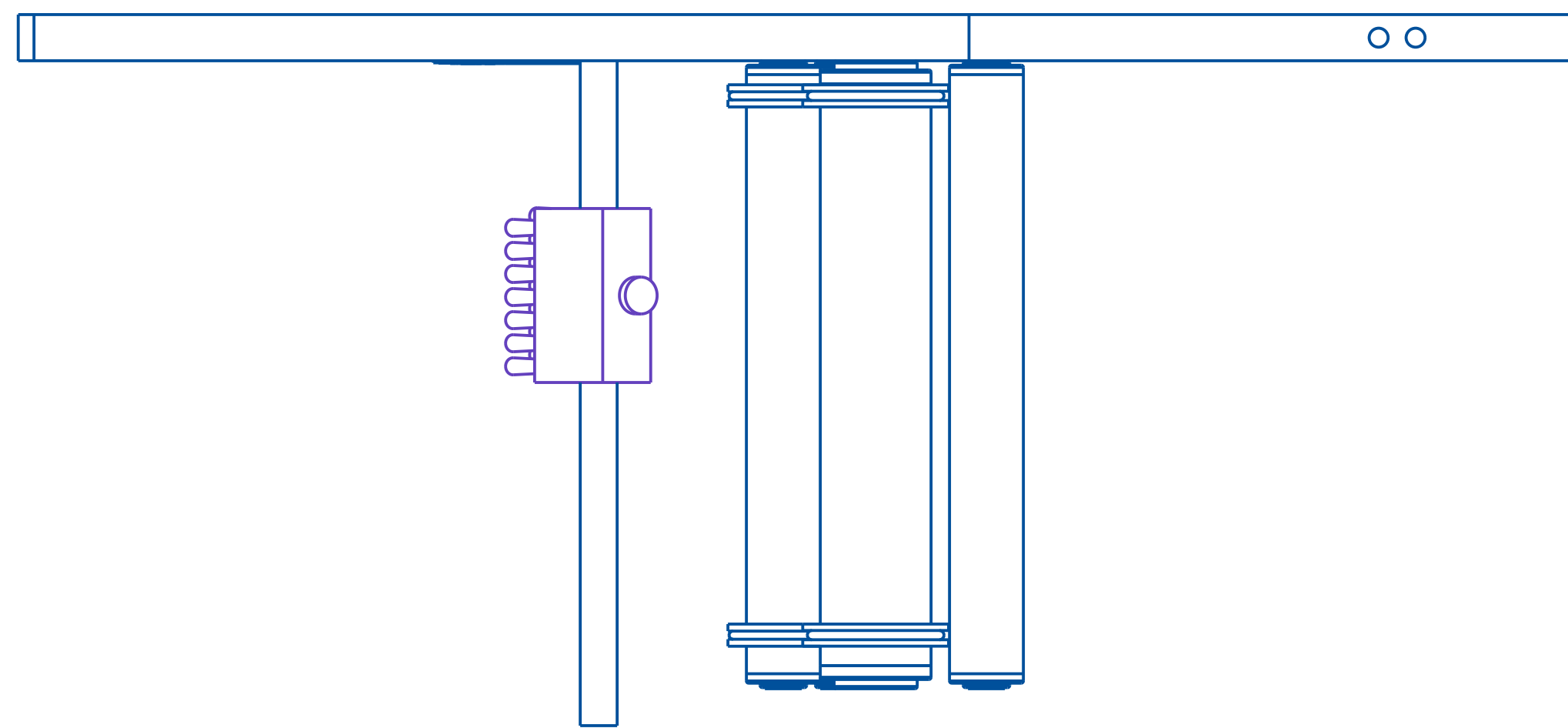

B	01/29/26	REVISED DRAWING	SEM
A	09/08/25	NEW DRAWING	SEM
REV	DATE	DESCRIPTION	BY

THIS IS A PRO-ENGINEER DOCUMENT AND MAY NOT BE MODIFIED MANUALLY

UNLESS OTHERWISE SPECIFIED
DIMENSIONAL TOLERANCE
x ± .1
xx ± .01
xxx ± .005
ANGLES ± .30°
SURFACE FINISH 125
BREAK ALL EDGES .005/.015
CORNER RADIUS .010/.030
ALL ANGLES ARE 90°

QUADREL LABELING SYSTEMS
7670 JENTHER DRIVE
MENTOR, OHIO 44060
(440) 602-4700

SCALE: 1/2
DATE: 09/08/25
DRW BY: SEM
CHK BY: 01/29/2026-SEM
APPR BY:

SIDE PLATE ASSEMBLY, 7"
MAT'L
23100SP-007LH

ASSEMBLY TITLE:

Q120 UNWIND ASSEMBLY

GENERAL FUNCTION:

- Unwind flange provides support for label rolls (side application)
- Dual flanges prevent roll and label movement (top application)
- Dancer arm prevents roll run-away.
- Idler roller with guide collars guides web through slot sensor.
- Brake brush prevents web buckling through slot sensor.

SET UP AND ADJUSTMENTS:

- Move flange to required height and tighten set screw in flange hub.
- For top labeling, add second flange and tighten ratchet knob.
- Adjust dancer tension by turning check nut so that dancer roll snaps back to braking position when labeling head is threaded.
- Slide brake brush so that center of brush lines up with center of web. Rotate brush to provide web tension, then lock into place using the locking knob.
- Position guide collars on idler roll, one slightly above, the other slightly below the web.

DANCER TENSION ADJUSTMENT LOCATION:

- **The unwind tension adjustment is located on the middle underside of the Q120 head. Use the knurled ring to adjust the dancer tension.**

MAINTENANCE:

- Clean all the parts that may acquire glue residue

TROUBLESHOOTING:

PROBLEM

- Unwind roll run-away
- Unwind roll not stopping
- Drive roll stalling
- Brush taking fixed shape

WHAT TO DO

- Tighten dancer spring, check nut or replace dancer spring, if necessary.
- Replace brake ring-belt if broken, or unevenly worn.
- Release web tension produced by brake brush.
- Turn brush around



ASSEMBLY TITLE: Q120 LABELING HEAD - DANCER ARM ASSEMBLY

DRAWING NO.: None Applicable

GENERAL FUNCTION:

- The dancer arm and braking mechanism are used to control the unwind unit which will only advance a few inches of web at any time
- The position of the dancer arm affects the advancement of the web off the label roll.

SET UP AND ADJUSTMENTS:

- The dancer normal position of the dancer arm is reached when the dancer arm locks the supply reel.
- The spring tension can be adjusted to correctly locate the dance arm
- The spring may be adjusted by turning the threaded tensioner located near the unwind unit.
- The spring should be tight enough to bring the dancer arm back to its normal position and hold it with some force, but not tight enough to tear the web during label feed.
- Spring adjustment is also possible by rotating the spring mounting pin on the spring take up pulley around the mounting shaft.
- While in its normal position, the dancer arm roller should not interfere with the supply reel flange.

MAINTENANCE:

- Replace dancer spring if final spring tension is too soft.

TROUBLESHOOTING:

PROBLEM

- Web break
- Too much web slack
- Dancer arm hits supply flange position by loosening the brake cam.

WHAT TO DO

- Lower spring tension on dancer arm
- Increase spring tension
- Correct dancer arm final

ASSEMBLY TITLE:

**Q120 LABELING HEAD - BRAKE BRUSH
ASSEMBLY**

GENERAL FUNCTION:

- The brake brush establishes web tension and controls backlash

SET UP AND ADJUSTMENTS:

- For accurate label feeds, the web must establish proper tension.
- Loosen the holding set screw in the brake brush body. The brake brush assembly can now be rotated on axis.
- Turn brush body into the web and tighten. To check for proper web tension, jog a label and check for web slack. If the web is tight and the label feeds correctly, the brush tension is set correctly.
- If backlash persists, continue to increase brake brush tension.

MAINTENANCE:

- Replace brake brush when brush body contour no longer viable or bristles are worn down.

TROUBLESHOOTING:

PROBLEM

- Web break

- Motor stall

- Too much web slack

WHAT TO DO

- Too much brake tension. Decrease until no slack in web.

- Debris or brake flaw causing web tear

- Decrease brake tension

- Increase brake tension

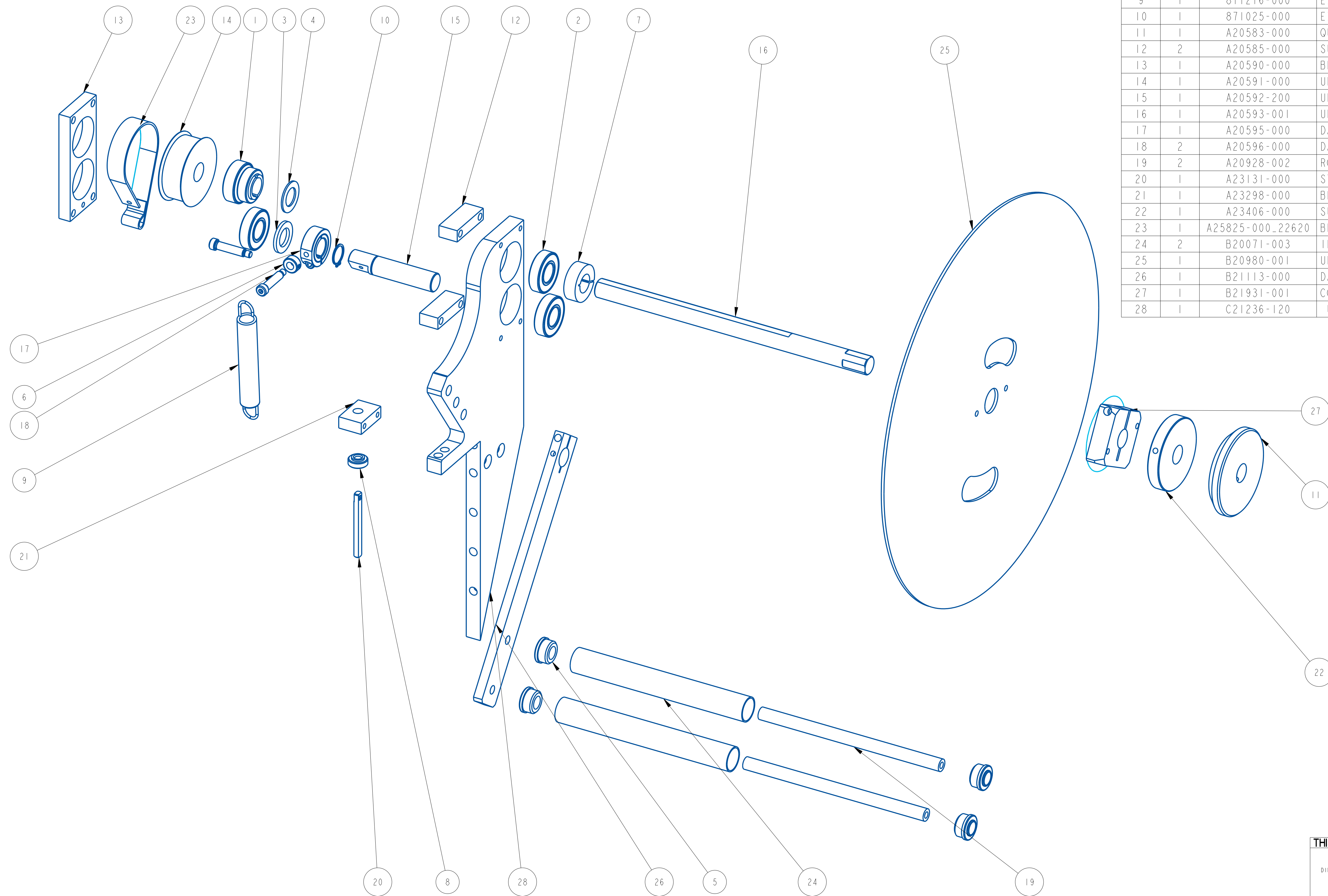

ITEM	QTY	PART NO.	DESCRIPTION	PARENT ITEM
1	1	111044-000	BEARING, 3/4 ID CLAMP TYPE	23100U-007LH
2	3	111074-000	BEARING, BALL	23100U-007LH
3	1	151001-000	BEARING, THRUST WASHER	23100U-007LH
4	1	151006-000	BEARING, THRUST WASHER	23100U-007LH
5	4	181063-000	BEARING, ROLL END	23100U-007LH
6	1	361165-000	COLLAR, SETSCREW, 5/16" BORE	23100U-007LH
7	1	361183-000	COLLAR, 3/4 ID ONE PIECE- S.S.	23100U-007LH
8	1	801601-000	CHECK NUT	23100U-007LH
9	1	811216-000	EXTENSION SPRING, STAINLESS	23100U-007LH
10	1	871025-000	EXTERNAL SNAP RING	23100U-007LH
11	1	A20583-000	QUICK LOCK COLLAR REWORK	23100U-007LH
12	2	A20585-000	SUPPORT SPACER	23100U-007LH
13	1	A20590-000	BEARING PLATE	23100U-007LH
14	1	A20591-000	UNWIND BRAKE DRUM	23100U-007LH
15	1	A20592-200	UNWIND DANCER SHAFT	23100U-007LH
16	1	A20593-001	UNWIND SHAFT	23100U-007LH
17	1	A20595-000	DANCER COLLAR	23100U-007LH
18	2	A20596-000	DANCER BOLT	23100U-007LH
19	2	A20928-002	ROLLER SHAFT	23100U-007LH
20	1	A23131-000	STUD	23100U-007LH
21	1	A23298-000	BLOCK, SPRING TENSION	23100U-007LH
22	1	A23406-000	SUPPLY REEL CENTER HUB	23100U-007LH
23	1	A25825-000_22620	BRAKE BAND	23100U-007LH
24	2	B20071-003	IDLER ROLLER (DANCER)	23100U-007LH
25	1	B20980-001	UNWIND FLANGE	23100U-007LH
26	1	B21113-000	DANCER ARM, 16" UNWIND	23100U-007LH
27	1	B21931-001	CORE HUB	23100U-007LH
28	1	C21236-120	UNWIND SUPPORT PLATE	23100U-007LH

REV	DATE	DESCRIPTION	BY
A	05-OCT-15	NEW DRAWING	CRT

THIS IS A PRO-ENGINEER DOCUMENT AND MAY NOT BE MODIFIED MANUALLY

UNLESS OTHERWISE SPECIFIED
 DIMENSIONAL TOLERANCE
 .XX ± .01
 .XXX ± .005
 ANGLES ± 30°

QUADREL LABELING SYSTEMS
 7670 JENTHER DRIVE
 MENTOR, OHIO 44060
 (440) 602-4700

SCALE: 1/2
 DATE: 05-OCT-15
 DRW BY: CRT
 CHK BY:
 APPR BY:

UNWIND ASSEMBLY, 7"

SURFACE FINISH 125
 BREAK ALL EDGES .005/0.15
 CORNER RADIUS .010/0.30

MAT'L 23100U-007LH

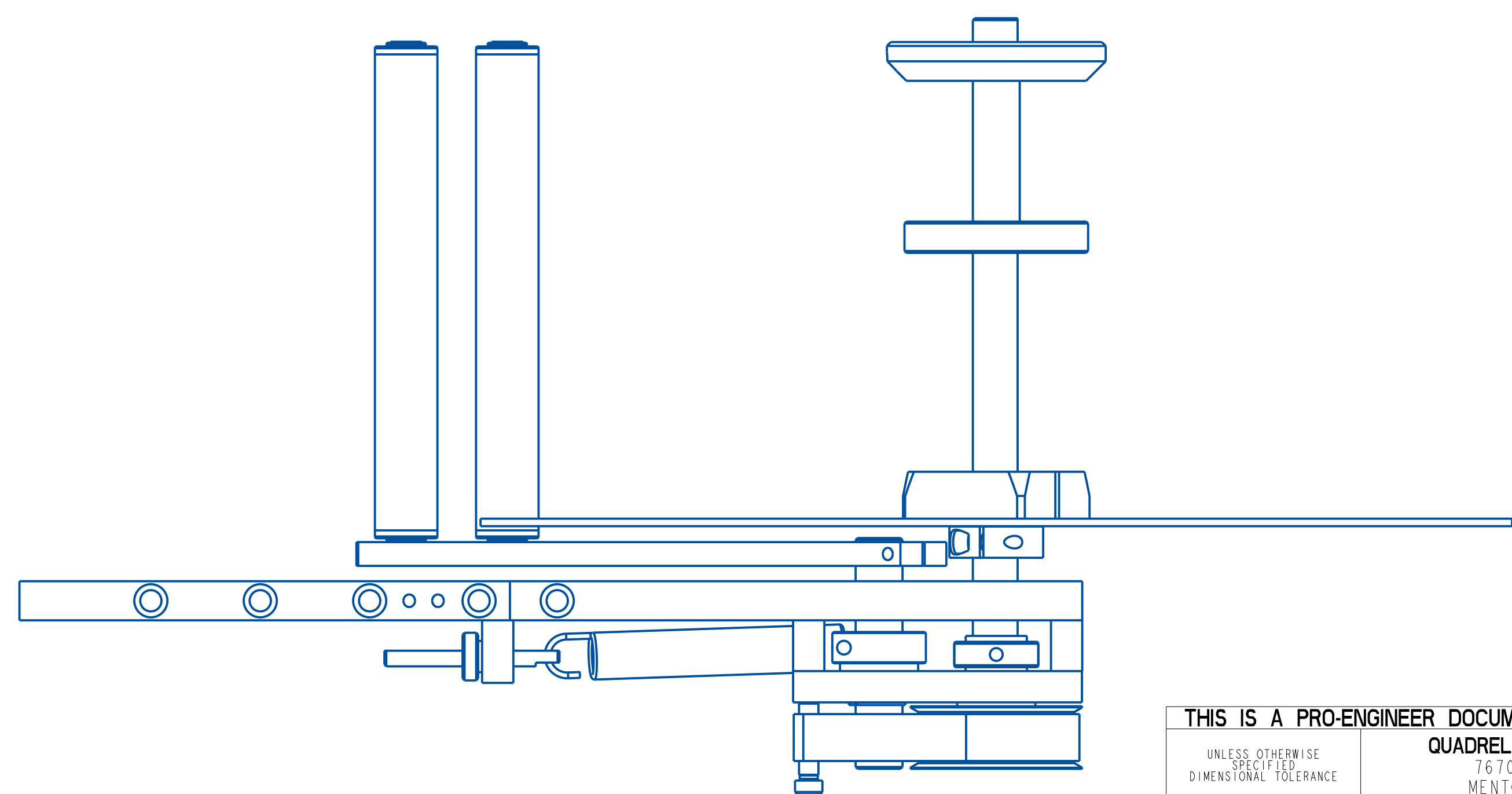
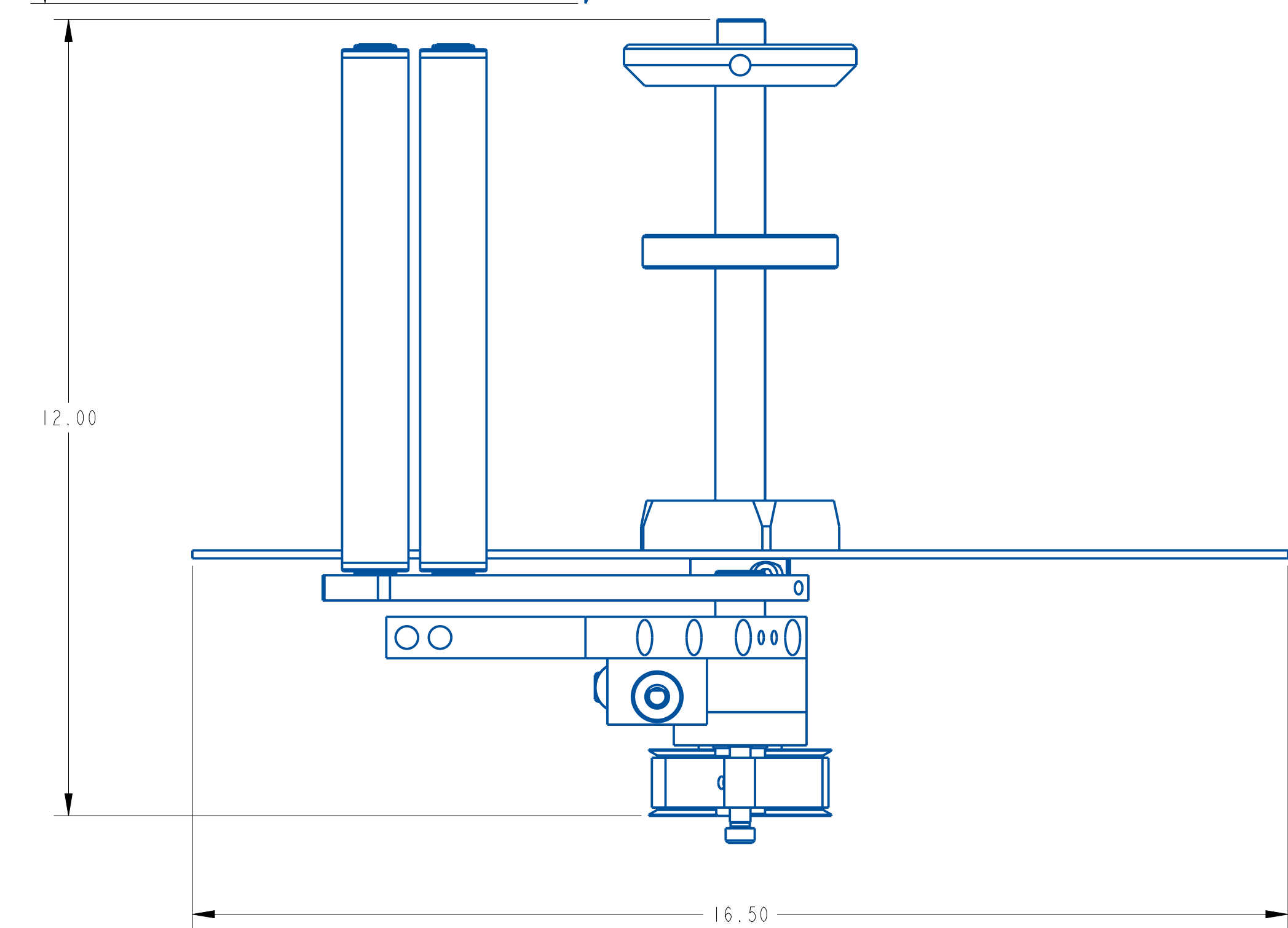
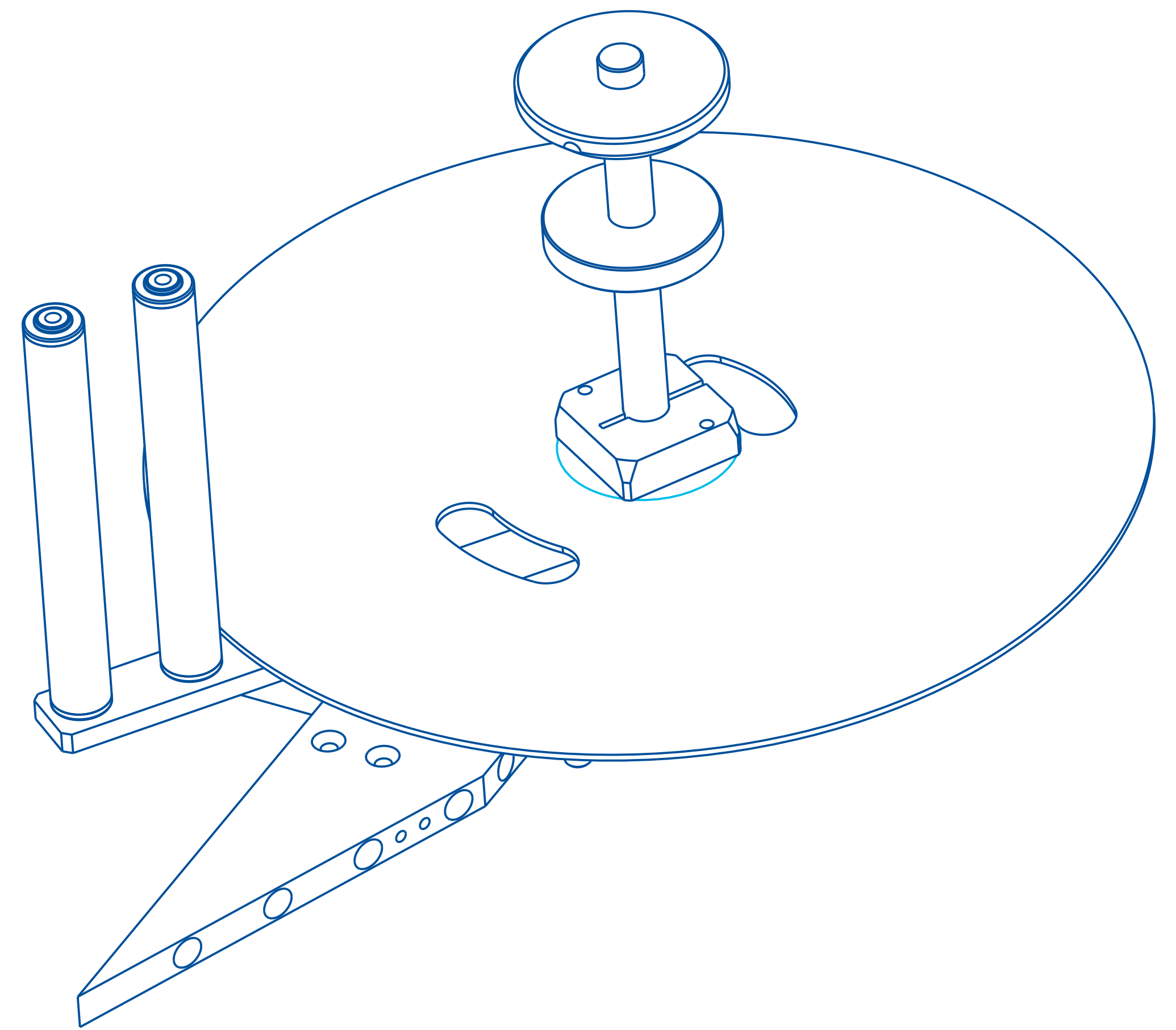
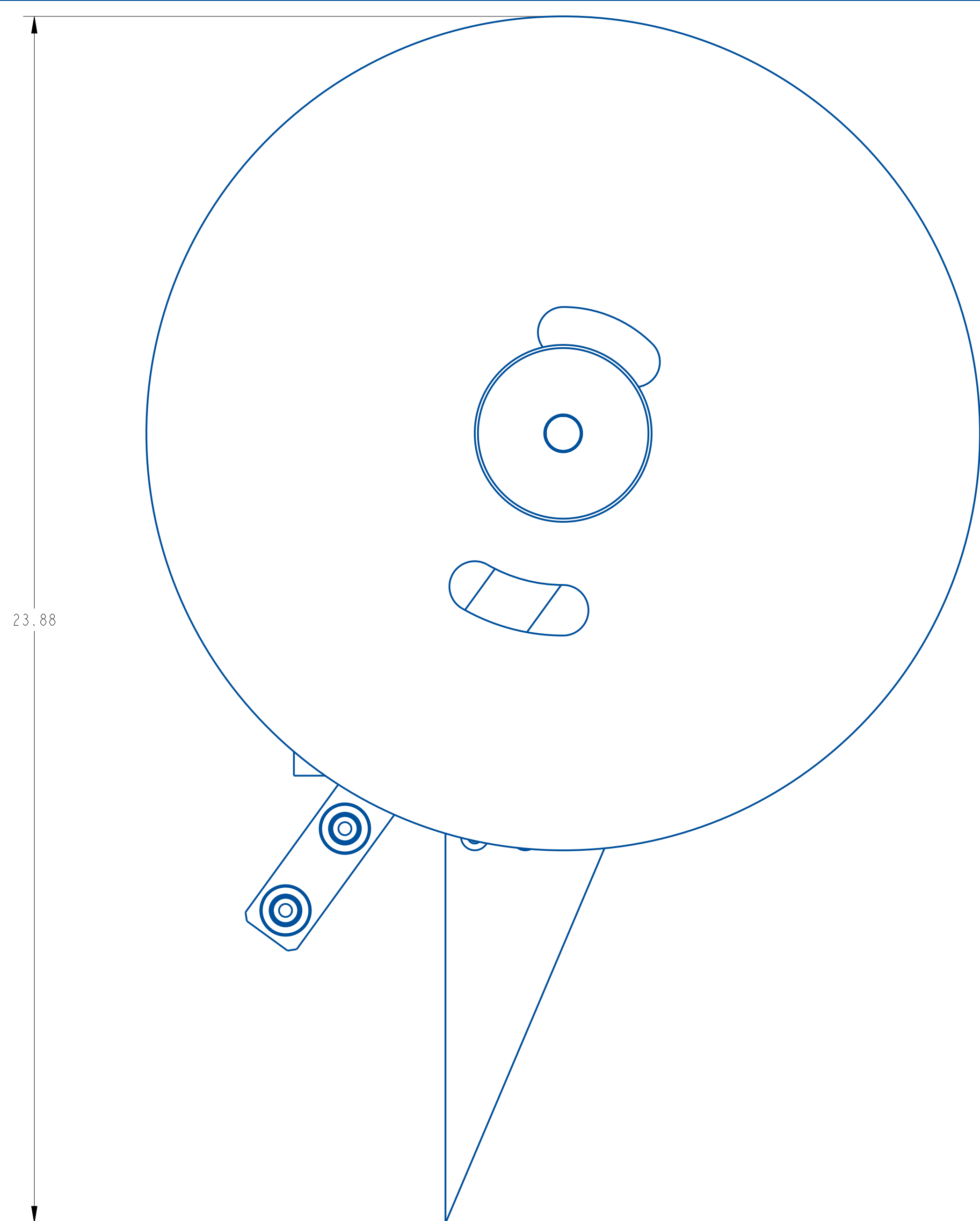

A		05-OCT-15	NEW DRAWING	CRT
REV	DATE	DESCRIPTION	BY	
UNLESS OTHERWISE SPECIFIED		DIMENSIONAL TOLERANCE		
x	±	.1		
xx	±	.01		
xxx	±	.005		
ANGLES		±	30°	
SURFACE FINISH		125		
BREAK ALL EDGES		.0057, .015		
CORNER RADIUS		.0107, .030		
THIS IS A PRO-ENGINEER DOCUMENT AND MAY NOT BE MODIFIED MANUALLY				
QUADREL LABELING SYSTEMS			SCALE	9/16
7670 JENTHER DRIVE			DATE	05-OCT-15
MENTOR, OHIO 44060			DRAWN BY	CRT
(440) 602-4700				
UNWIND ASSEMBLY, 7"				
MAT'L	23100U-007LH	23100U-007LH		

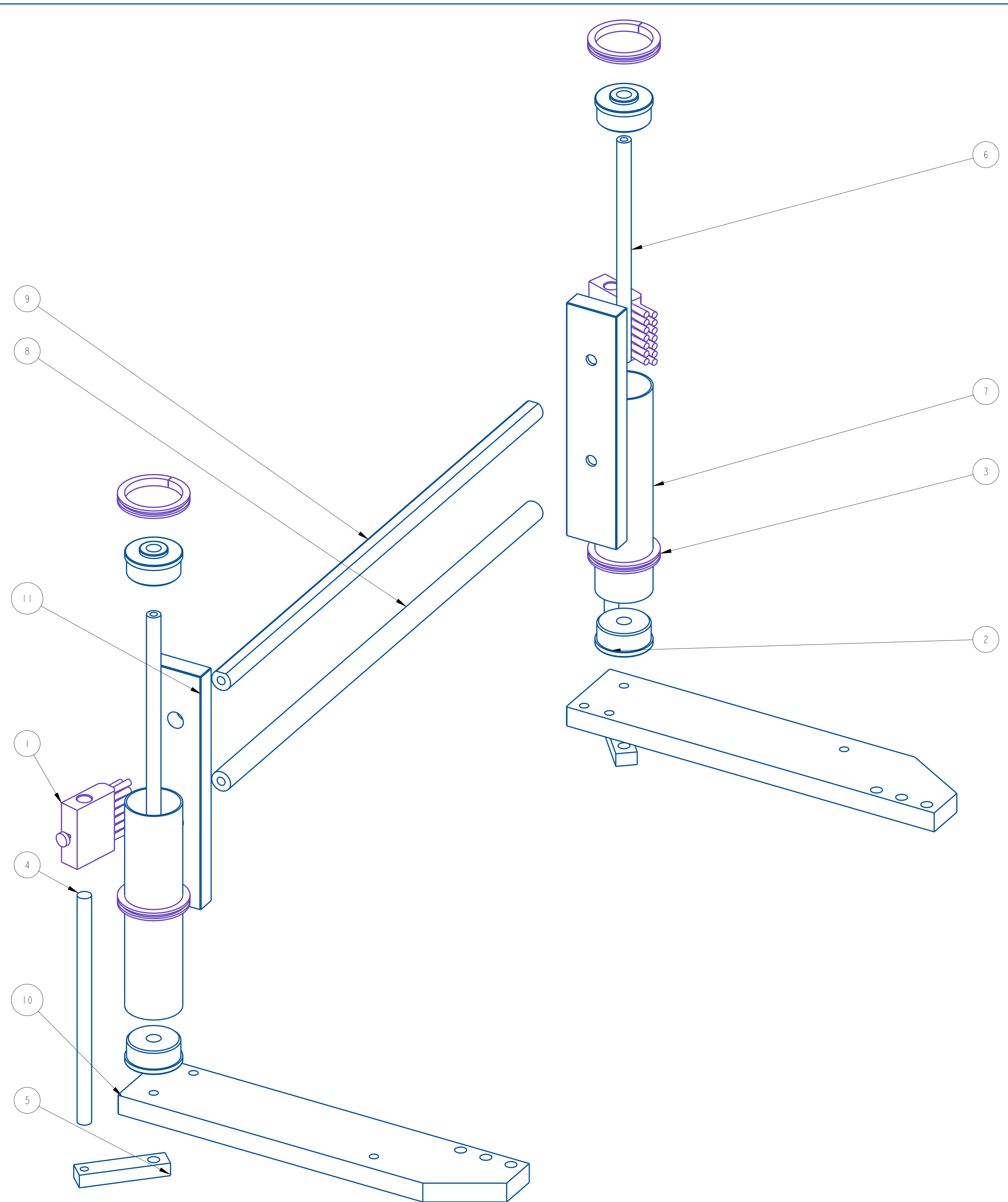

ITEM	QTY	PART NO.	DESCRIPTION	PARENT ITEM
1	2	00669-01	BRAKE BRUSH 2 x 7 nylon	22620HS-002
2	4	181073-000	BEARING, ROLL END	22620HS-002
3	4	361200-000	COLLAR, GUIDE, 2" ID	22620HS-002
4	2	A20654-003	ADJ. ROD	22620HS-002
5	2	A21535-001	BRAKE BRUSH MTG. BAR	22620HS-002
6	2	A25695-000	ROLLER SHAFT	22620HS-002
7	2	A25696-000	IDLER ROLLER	22620HS-002
8	1	A25750-021_50	PEEL PLATE MTG. ROD	22620HS-002
9	1	A25751-021_50	PEEL PLATE MTG. ROD	22620HS-002
10	2	B22301-118	RAIL HOLDER MTG PLATE	22620HS-002
11	2	B22531-002	RAIL MTG BAR	22620HS-002

REV	DATE	DESCRIPTION	BY
A	Feb-12-26	NEW DRAWING	TAZ

THIS IS A PRO-ENGINEER DOCUMENT AND MAY NOT BE MODIFIED MANUALLY

UNLESS OTHERWISE SPECIFIED DIMENSIONAL TOLERANCE .1 .01 .005 ANGLES ± 30° SURFACE FINISH 125 BREAK ALL EDGES .005/.015 CORNER RADIUS .010/.030	QUADREL LABELING SYSTEMS 7670 JENTHER DRIVE MENTOR, OHIO 44060 (440) 602-4700		SCALE: 1/2 DATE: Feb-12-26 DRW BY: TAZ CHK BY: APPR BY:
	Q105/110/120/125 HOT STAMP KIT		
	MAT'L	22620HS-002	22620HS-002

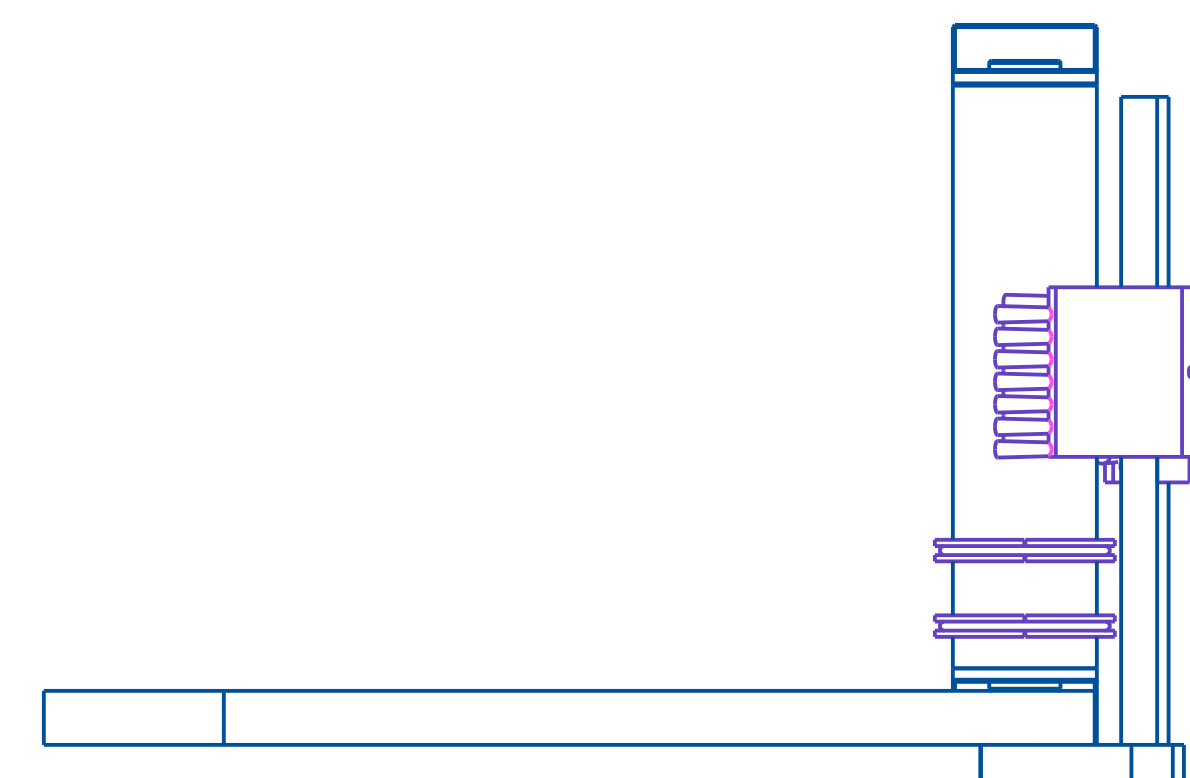
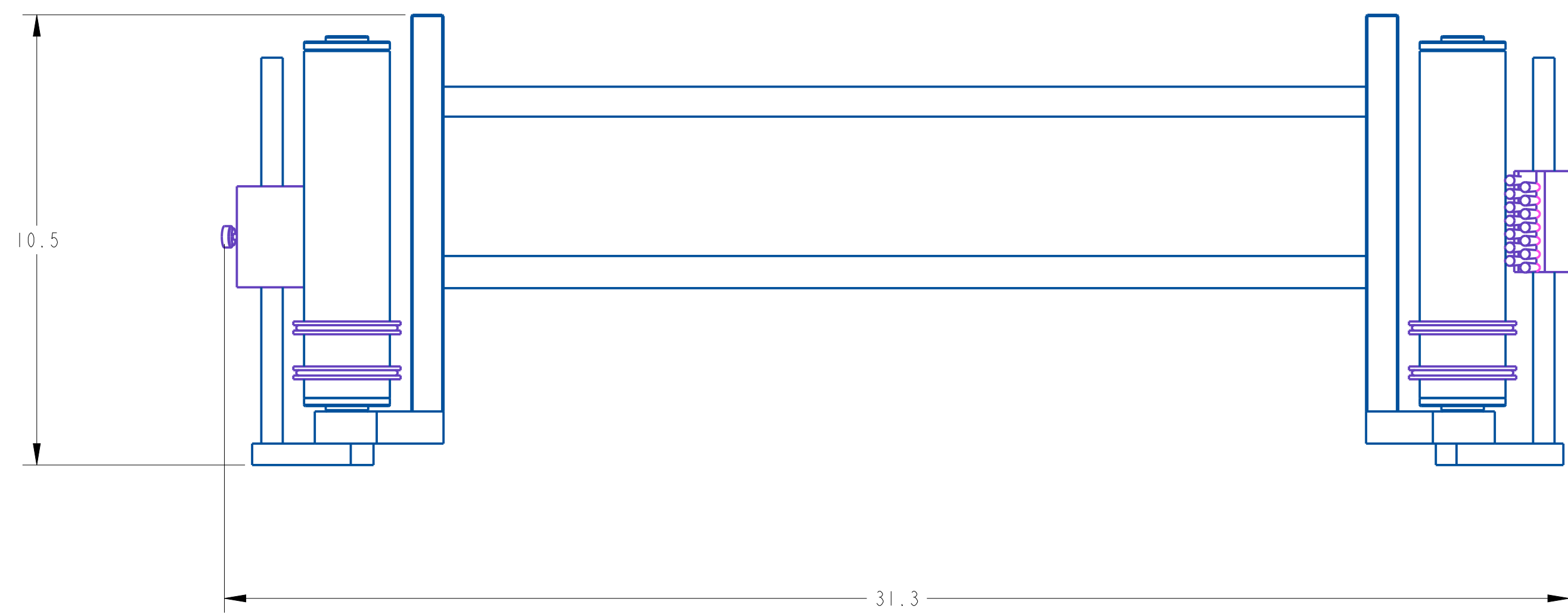
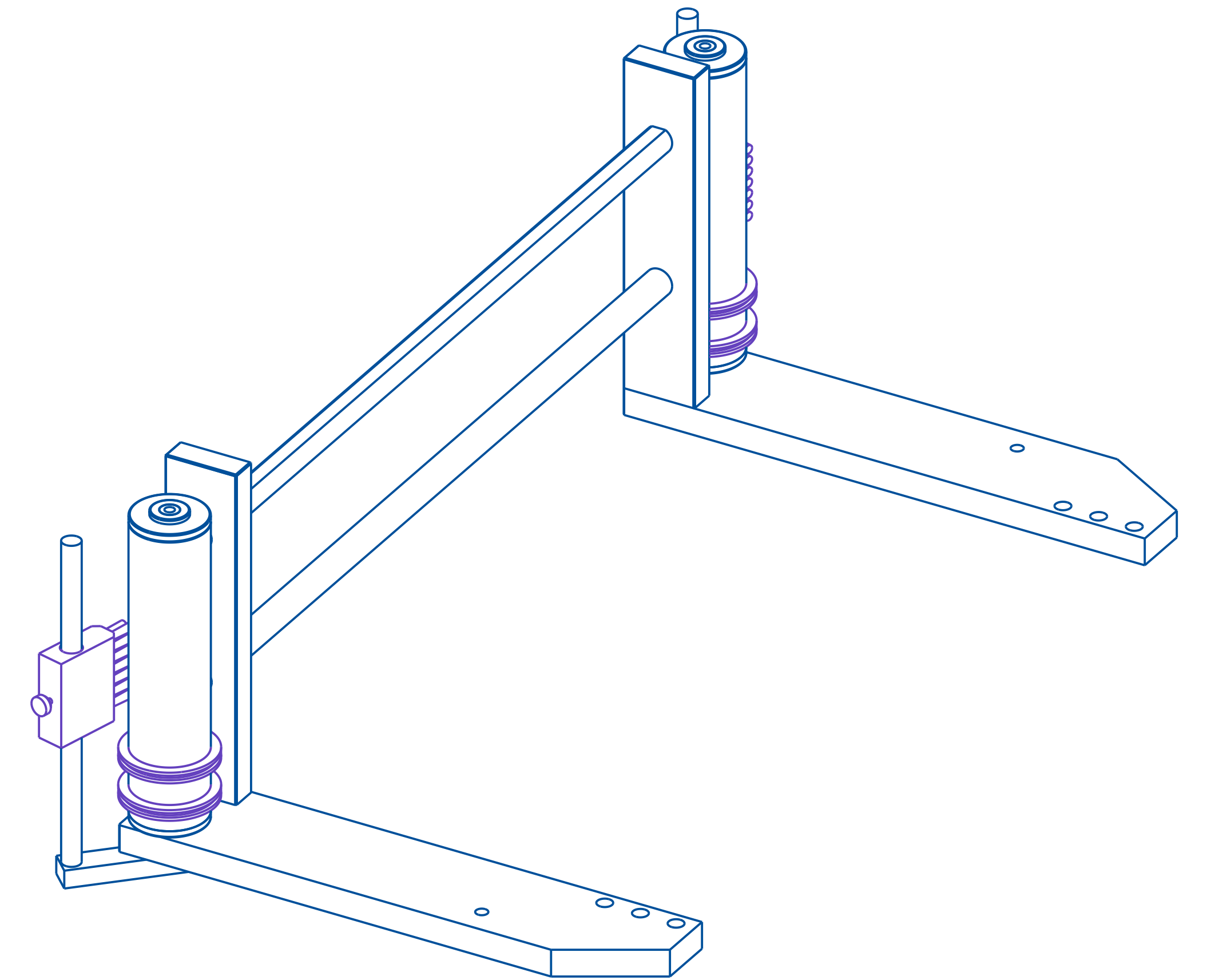
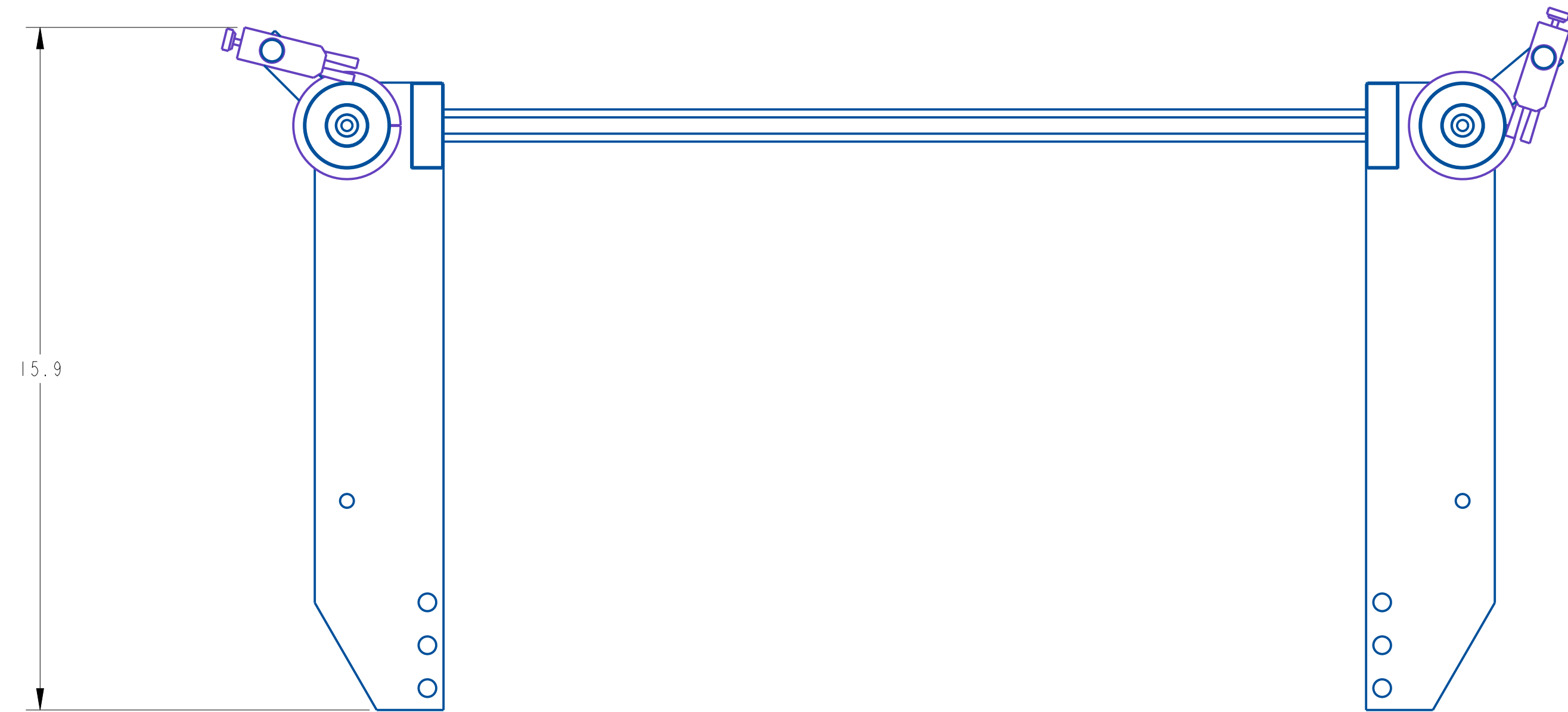

REV	DATE	DESCRIPTION	BY
A	Feb-12-26	NEW DRAWING	TAZ

THIS IS A PRO-ENGINEER DOCUMENT AND MAY NOT BE MODIFIED MANUALLY

UNLESS OTHERWISE SPECIFIED DIMENSIONAL TOLERANCE	QUADREL LABELING SYSTEMS 7670 JENTHER DRIVE MENTOR, OHIO 44060 (440) 602-4700	SCALE: 3/8 DATE: Feb-12-26 DRW BY: TAZ CHK BY: APPR BY:
.x ± .1 .xx ± .01 .xxx ± .005 ANGLES ± .30° SURFACE FINISH 125 BREAK ALL EDGES .005/0.15 CORNER RADIUS .010/0.30 ALL ANGLES ARE 90°	Q105/110/120/125 HOT STAMP KIT	
MAT'L	22620HS-002	22620HS-002

ASSEMBLY TITLE: MOUNTING BRACKET ASSEMBLY

DRAWING NO.: D21825-000

GENERAL FUNCTION:

- The bracket assembly is the main mounting assembly to mount the imprinter to the head .
- Adjustments are provided to set the imprinters location on the label.

SET UP AND ADJUSTMENTS:

- Loosen the locking handle on top of assembly use the adjusting knob to make the correction of the imprinter head.
- Re-tighten each handle when the correct angular position is set.

NOTE: Make sure each handle is secure, the imprinter head is heavy and could rotate if the locking handles are not firmly secured.

MAINTENANCE:

- No scheduled maintenance for this assembly.

TROUBLESHOOTING:

Problem

- Labeler angular position moves

What To Do

Secure locking tension by turning locking handles clockwise

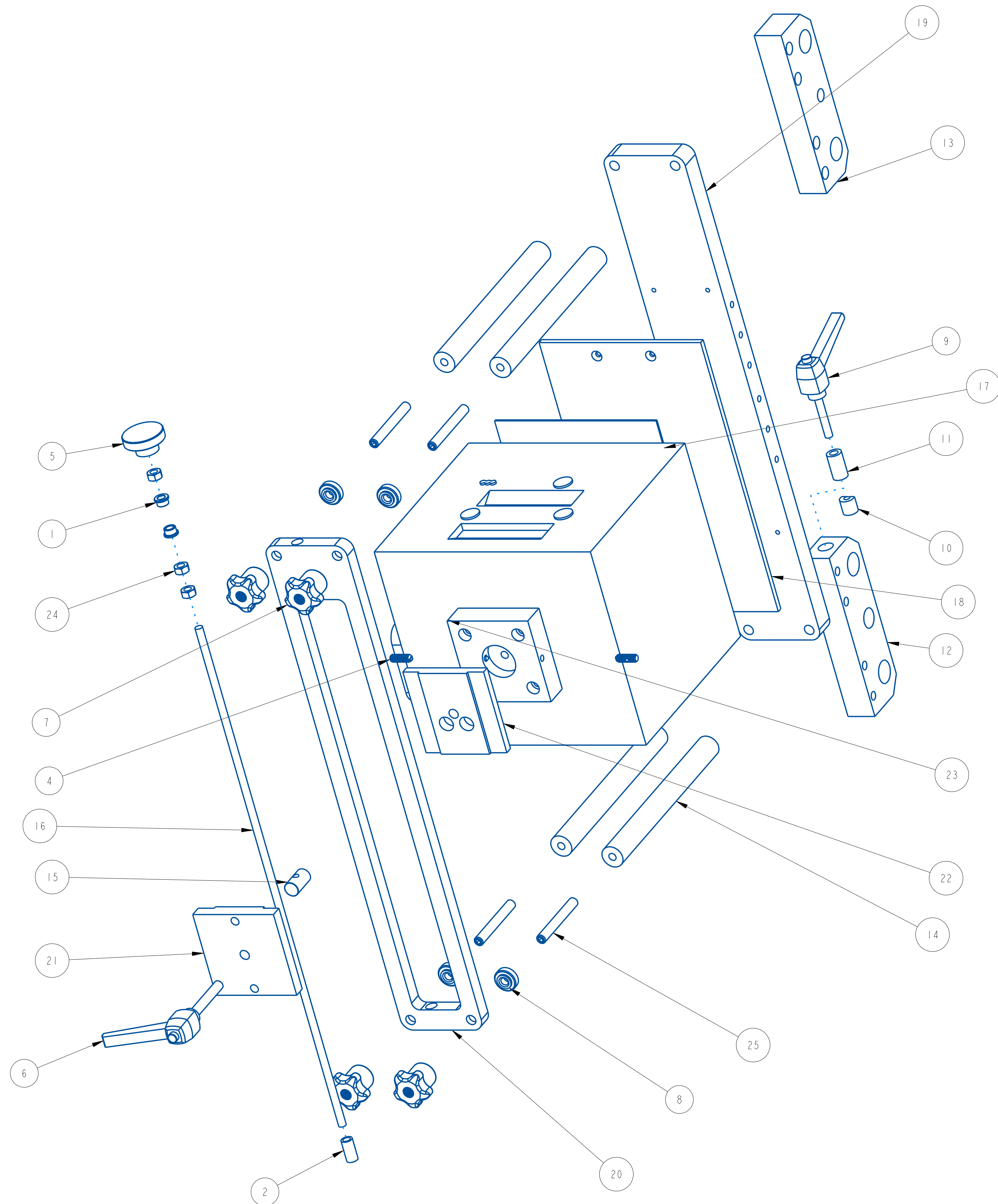

ITEM	QTY	PART NO.	DESCRIPTION	PARENT ITEM
1	2	131074-000	BEARING, FLANGED	21928-621
2	1	141095-000	SLEEVE BEARING	21928-621
3	1	771392-002	VIDEO JET 6230 32MM RH	21928-621
4	2	791531-000	SPRING PLUNGER, 1/4-20	21928-621
5	1	801274-000	KNOB, 1/4-20	21928-621
6	1	801312-000	CLAMPING LEVER	21928-621
7	4	801327-000	KNOB	21928-621
8	4	801601-000	CHECK NUT	21928-621
9	1	801836-000	CLAMPING LEVER	21928-621
10	1	A21008-000	LOCKING CLAMP (THREADED)	21928-621
11	1	A21009-000	LOCKING CLAMP (CLEARANCE)	21928-621
12	1	A21154-001	PRINTER MTG. PLATE - LOCKING (7" WEB)	21928-621
13	1	A21155-001	PRINTER MTG. PLATE (7" WEB)	21928-621
14	4	A24438-004	SPACER, ROD	21928-621
15	1	A24440-000	BRASS, NUT	21928-621
16	1	A24442-000	THREADED ROD	21928-621
17	1	A25075-001	IMPRINTER PAD	21928-621
18	1	A25140-000	IMPRINTER PLATE	21928-621
19	1	B21565-001	END PLATE, MOUNTING	21928-621
20	1	B21566-000	TOP PLATE, MOUNTING	21928-621
21	1	B21568-000	SLIDING PLATE, MOUNTING	21928-621
22	1	B21569-000	INDEX PLATE, MOUNTING	21928-621
23	1	B21570-000	BLOCK, MOUNTING SMART DATE	21928-621
24	3	RHN010		21928-621
25	4	SYE616		21928-621

REV	DATE	DESCRIPTION	BY
A	11-26-13	NEW DRAWING	CRT

THIS IS A PRO-ENGINEER DOCUMENT AND MAY NOT BE MODIFIED MANUALLY

UNLESS OTHERWISE SPECIFIED
 DIMENSIONAL TOLERANCE
 .X ± .1
 .XX ± .01
 .XXX ± .005
 ANGLES ± 30°

SURFACE FINISH 125
 BREAK ALL EDGES .005/0.15
 CORNER RADIUS .010/0.30

QUADREL LABELING SYSTEMS
 7670 JENTHER DRIVE
 MENTOR, OHIO 44060
 (440) 602-4700

SCALE: 1/2
 DATE: 11-26-13
 DRW BY: CRT
 CHK BY: 05/17/2024-SEM
 APPR BY:

CODER MOUNT SMARTDATE

MAT'L 21928-621

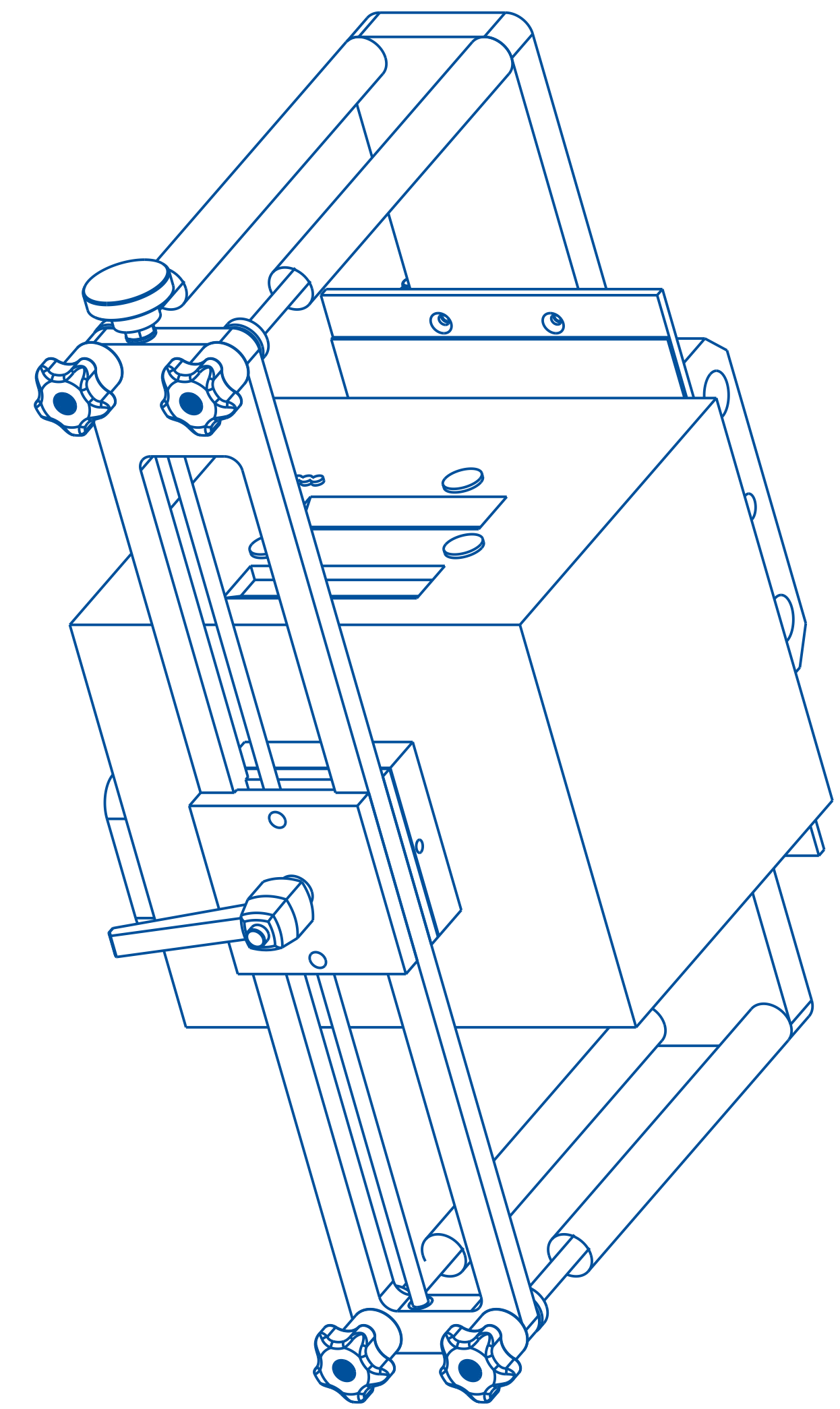
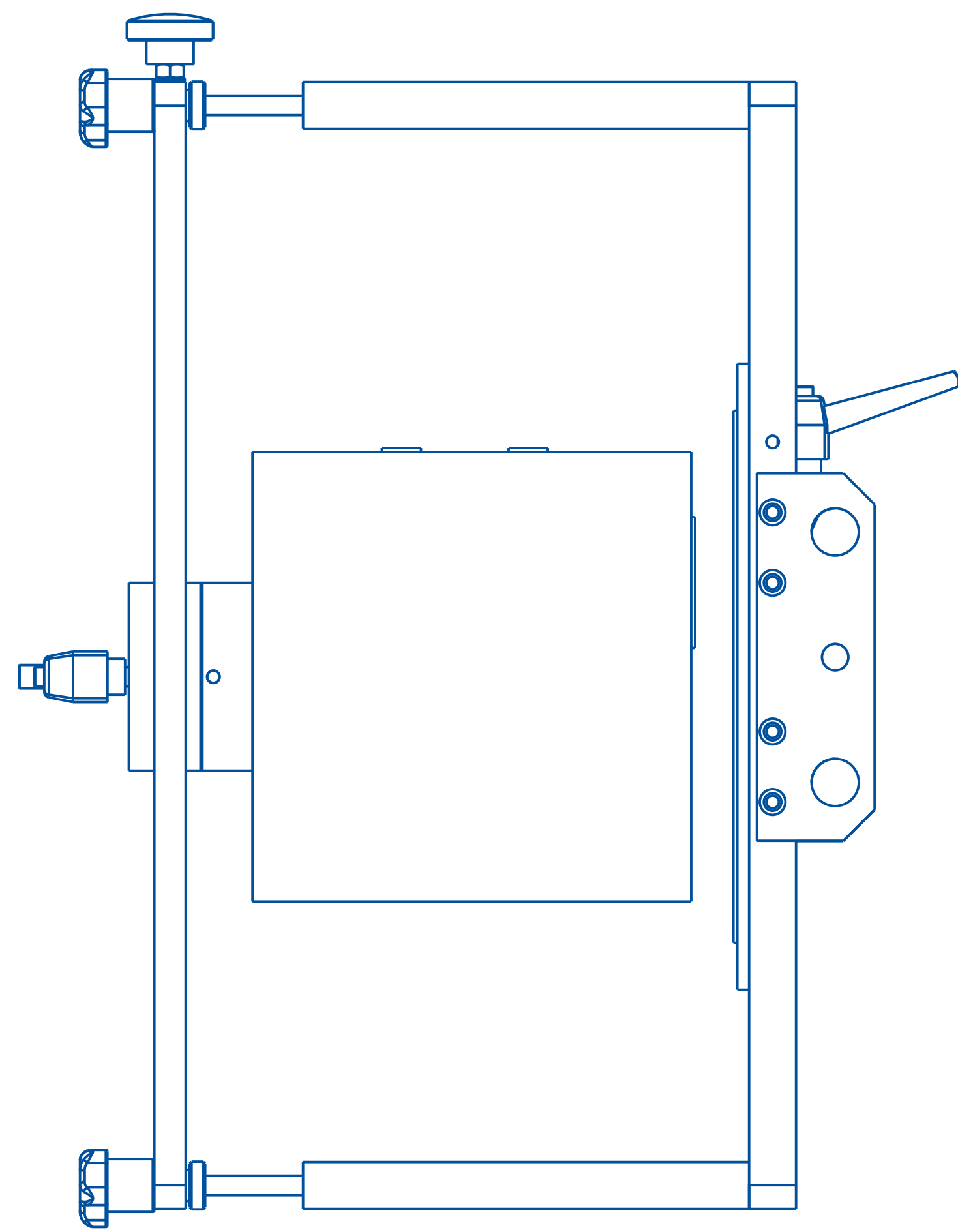
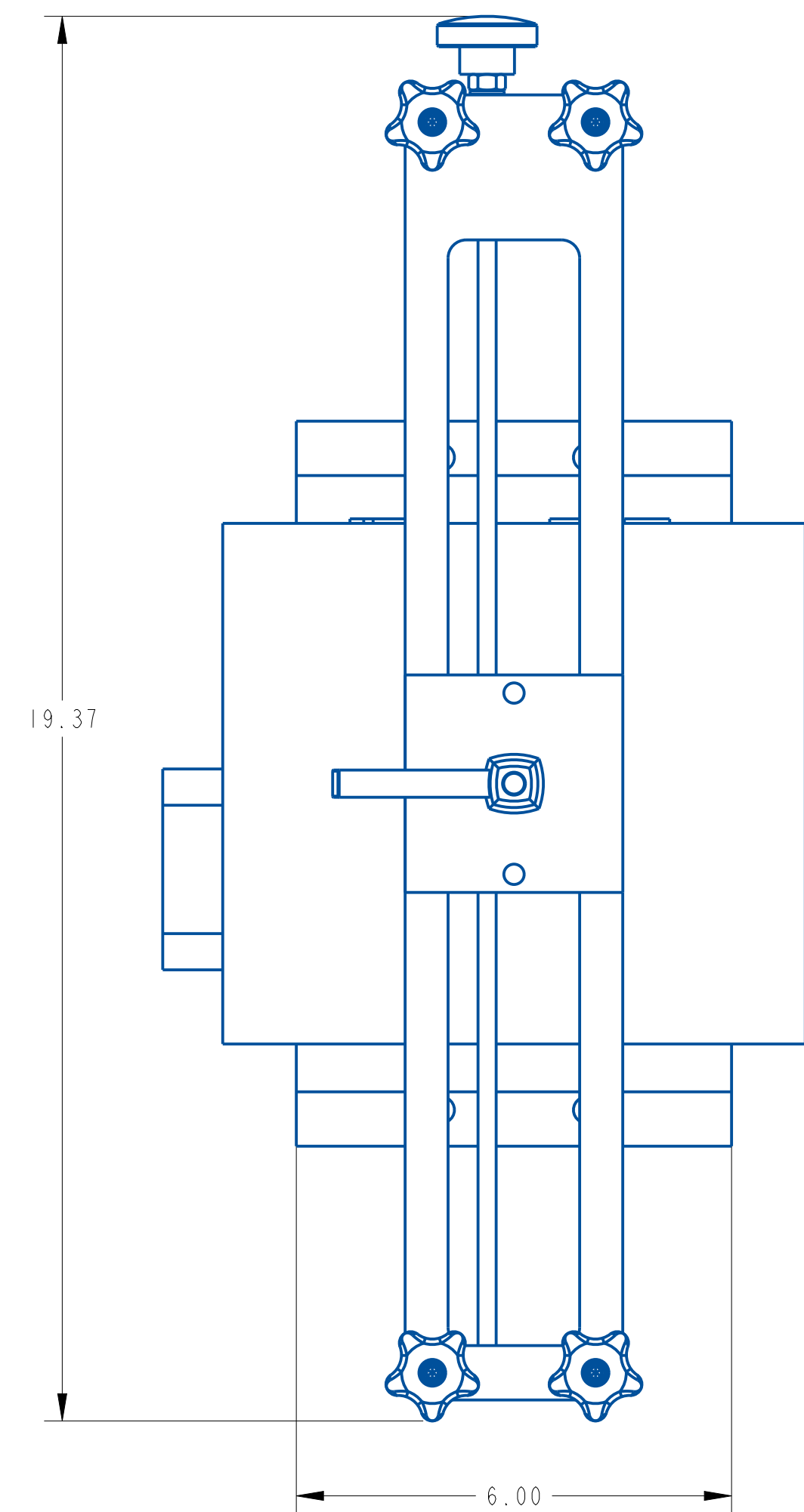
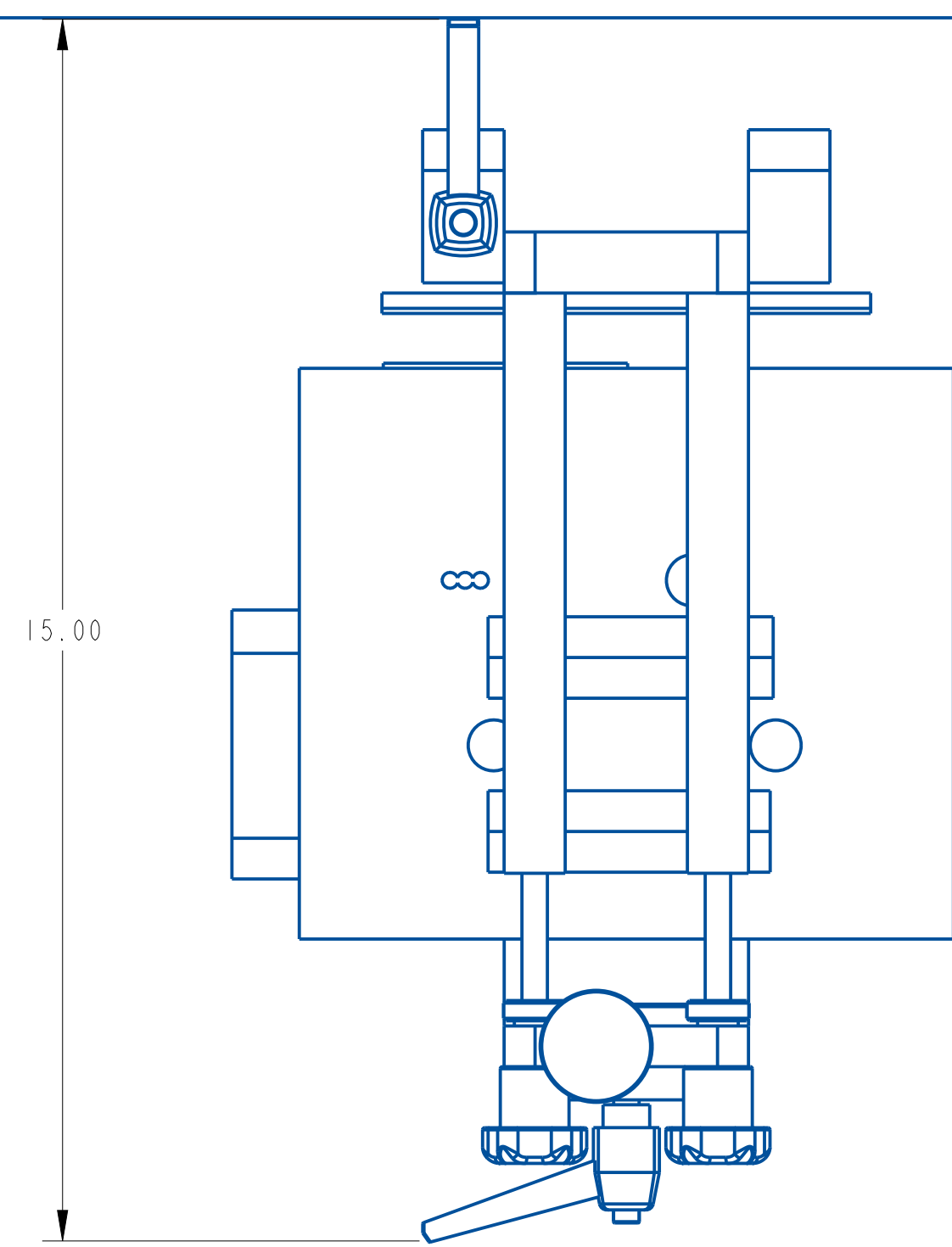

A	11-26-13	NEW DRAWING	CRT
REV	DATE	DESCRIPTION	BY

THIS IS A PRO-ENGINEER DOCUMENT AND MAY NOT BE MODIFIED MANUALLY

UNLESS OTHERWISE SPECIFIED
DIMENSIONAL TOLERANCE
X ± .1
XX ± .01
XXX ± .005
ANGLES ± .30°
SURFACE FINISH 125
BREAK ALL EDGES .005/0.15
CORNER RADIUS .010/0.30
ALL ANGLES ARE 90°

QUADREL LABELING SYSTEMS
7670 JENTHER DRIVE
MENTOR, OHIO 44060
(440) 602-4700
SCALE: 1/2
DATE: 11-26-13
DRW BY: CRT
CHK BY: 05/17/2024-SEM
APPR BY:
CODER MOUNT SMARTDATE
MAT'L
21928-621

ASSEMBLY TITLE: Q120 PEEL PLATE ASSEMBLY

GENERAL FUNCTION:

- The peel plate separates the label from the liner and puts the label in a "Flag" position.
- The mounting rods support the slot sensor assembly.
- The guide collars and the idler roller guide the web position over the peel plate
- The pivot pin provides for yoke mounting of the labeling head.

SET UP AND ADJUSTMENTS:

- On machines so equipped, the peel plate may be pivoted at various angles relating to the product by loosening the peel plate mounting bar. (The peel plate of all other models is mounted at a fixed angle and cannot be adjusted)
- To advance label flag on peel plate, move the slot sensor towards the peel plate. To decrease label flag, move slot sensor away from the peel plate.
- Position guide collars on idler roll, one slightly above and the other slightly below the web.

MAINTENANCE:

- Clean all the parts that may acquire labels or glue residue.

TROUBLESHOOTING:

PROBLEM

- Too much label flag at peel plate
- Too little label flag at peel plate
- Web moving up and down peel plate

WHAT TO DO

- Move slot sensor away from peel edge
- Move slot sensor towards peel plate edge
- Make sure guide collars are properly positioned on idler roll.



ITEM	QTY	PART NO.	DESCRIPTION	PARENT ITEM
1	6	181063-000	BEARING, ROLL END	21720-000
2	4	361198-000	COLLAR, GUIDE, 1 IN. ID	21720-000
3	2	A22065-000	PEEL PLATE MOUNTING PLATE	21720-000
4	2	A22066-000	WASHER	21720-000
5	1	A22094-001	PEEL PLATE ROD MTG BAR, 7"	21720-000
6	3	A22102-001	P.P. IDLER SHAFT	21720-000
7	1	A23946-001	PEEL PLATE MOUNTING BAR, 7"	21720-000
8	3	B20740-001	IDLER ROLLER-(PEEL PLATE)	21720-000

NOT SHOWN:
B21281-000 PEEL PLATE
791852-000 PEEL PLATE TAPE

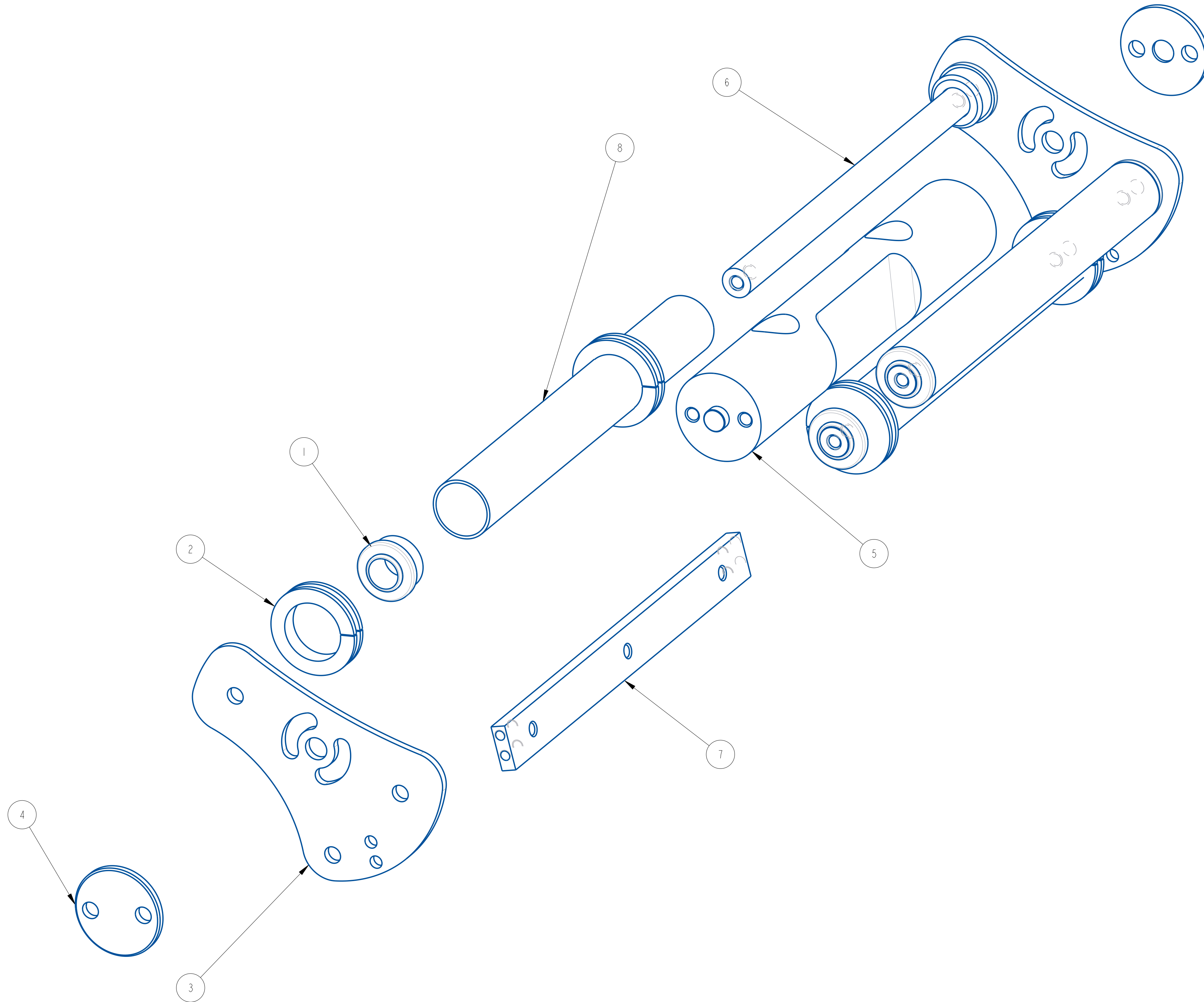

REV	DATE	DESCRIPTION	BY
B	12-FEB-2024	UPDATE DRAWING AND BOM	CRT
A	02/27/2006	NEW DRAWING	SEM

THIS IS A PRO-ENGINEER DOCUMENT AND MAY NOT BE MODIFIED MANUALLY

<small>UNLESS OTHERWISE SPECIFIED DIMENSIONAL TOLERANCE</small> xx ± .01 xxx ± .005 ANGLES ± 30°	QUADREL LABELING SYSTEMS 7670 JENTHER DRIVE MENTOR, OHIO 44060 (440) 602-4700	SCALE: 1/1 DATE: 02/27/2006 DRW BY: SEM CHK BY: APPR BY:	
	7" PEEL PLATE ASSEMBLY		
	MAT'L	BOM 21720-000	21720-000

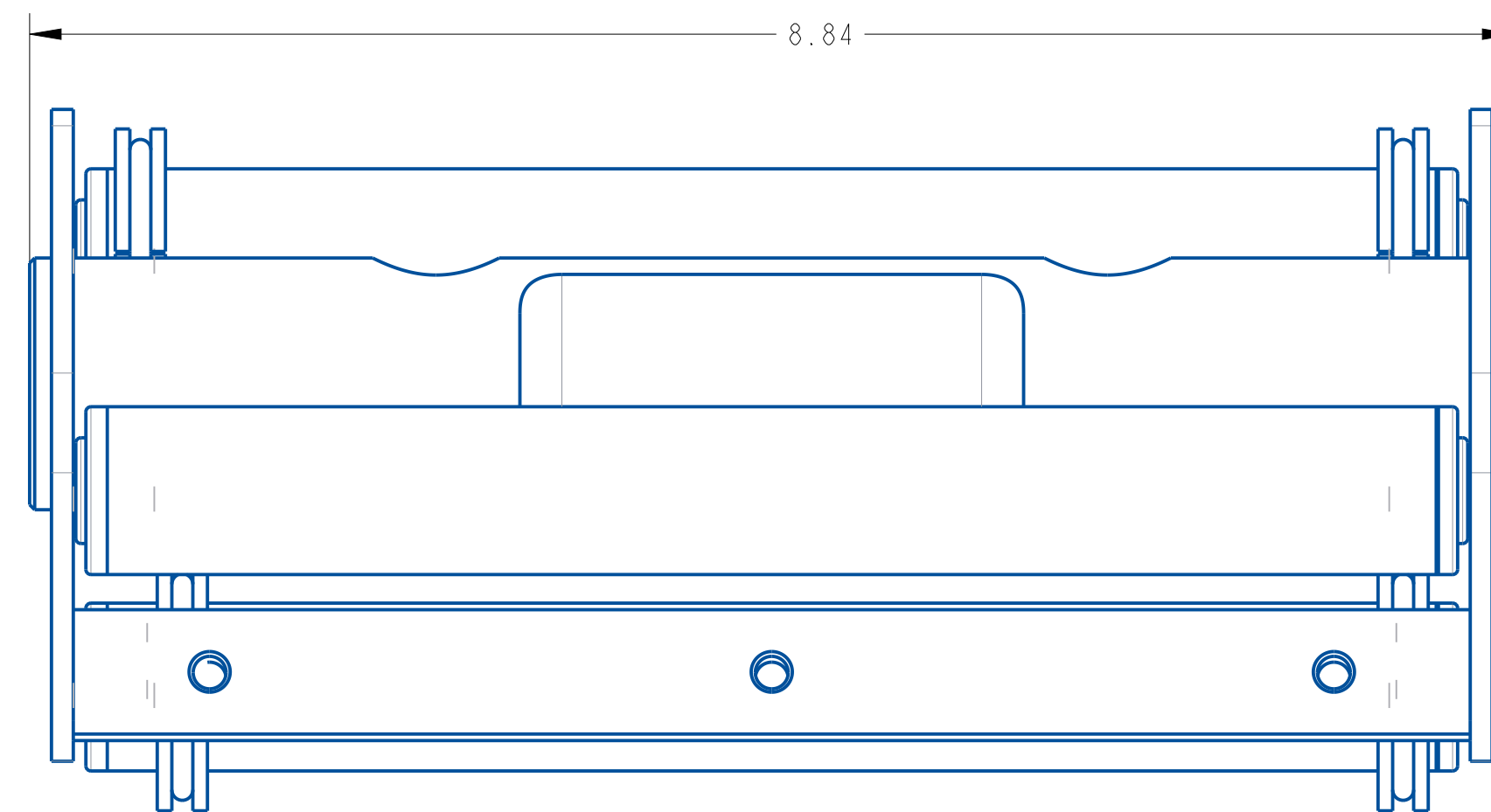
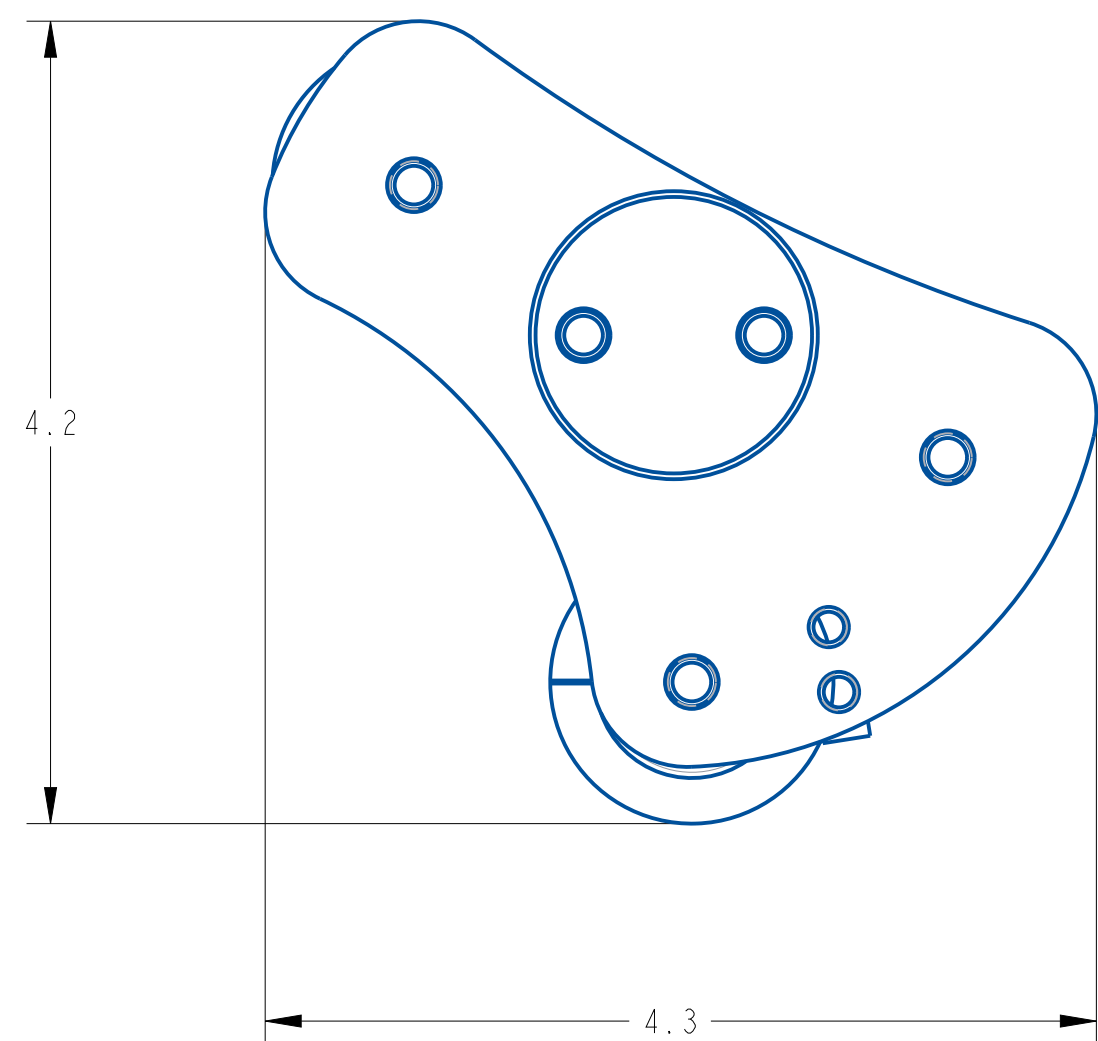
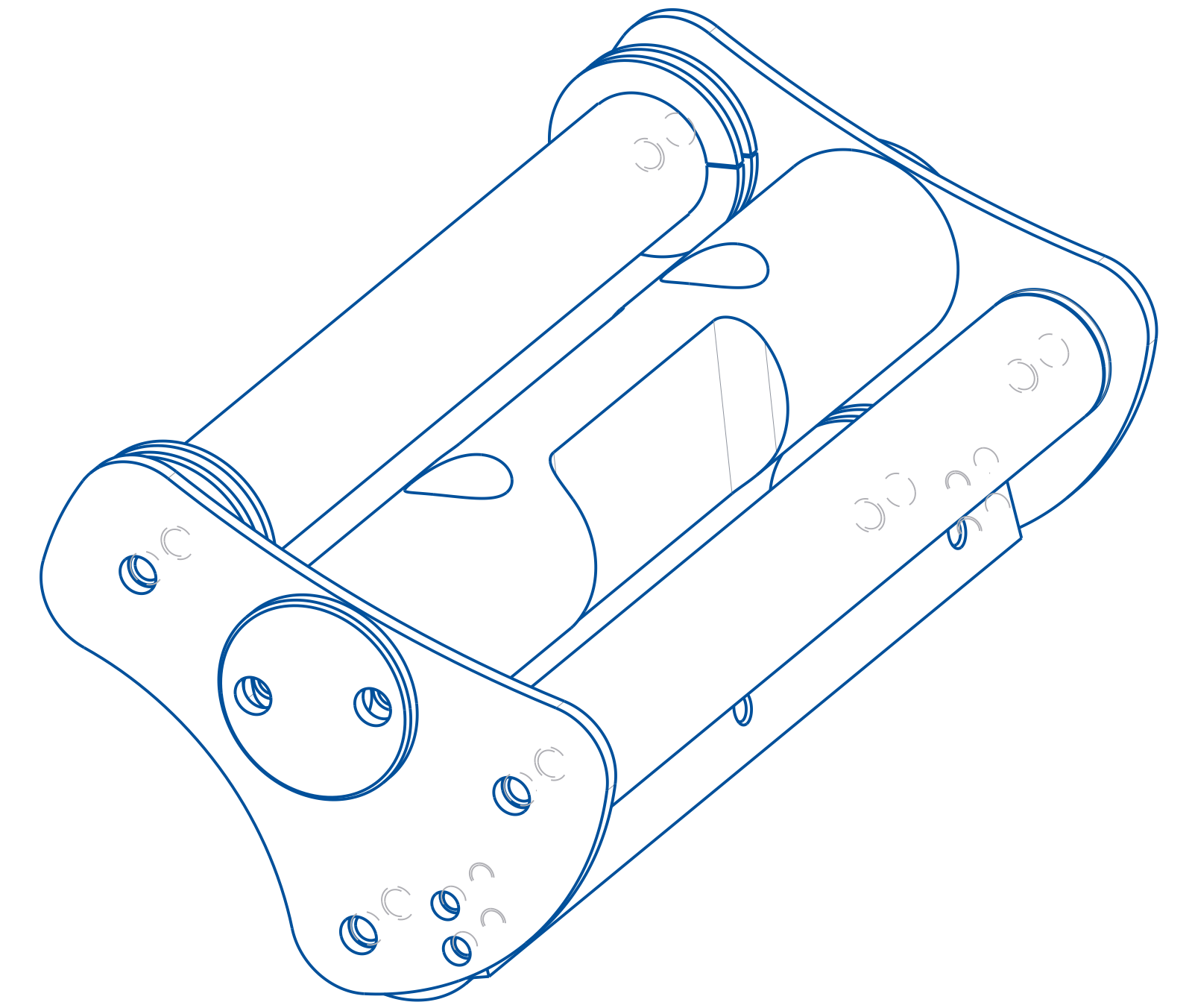
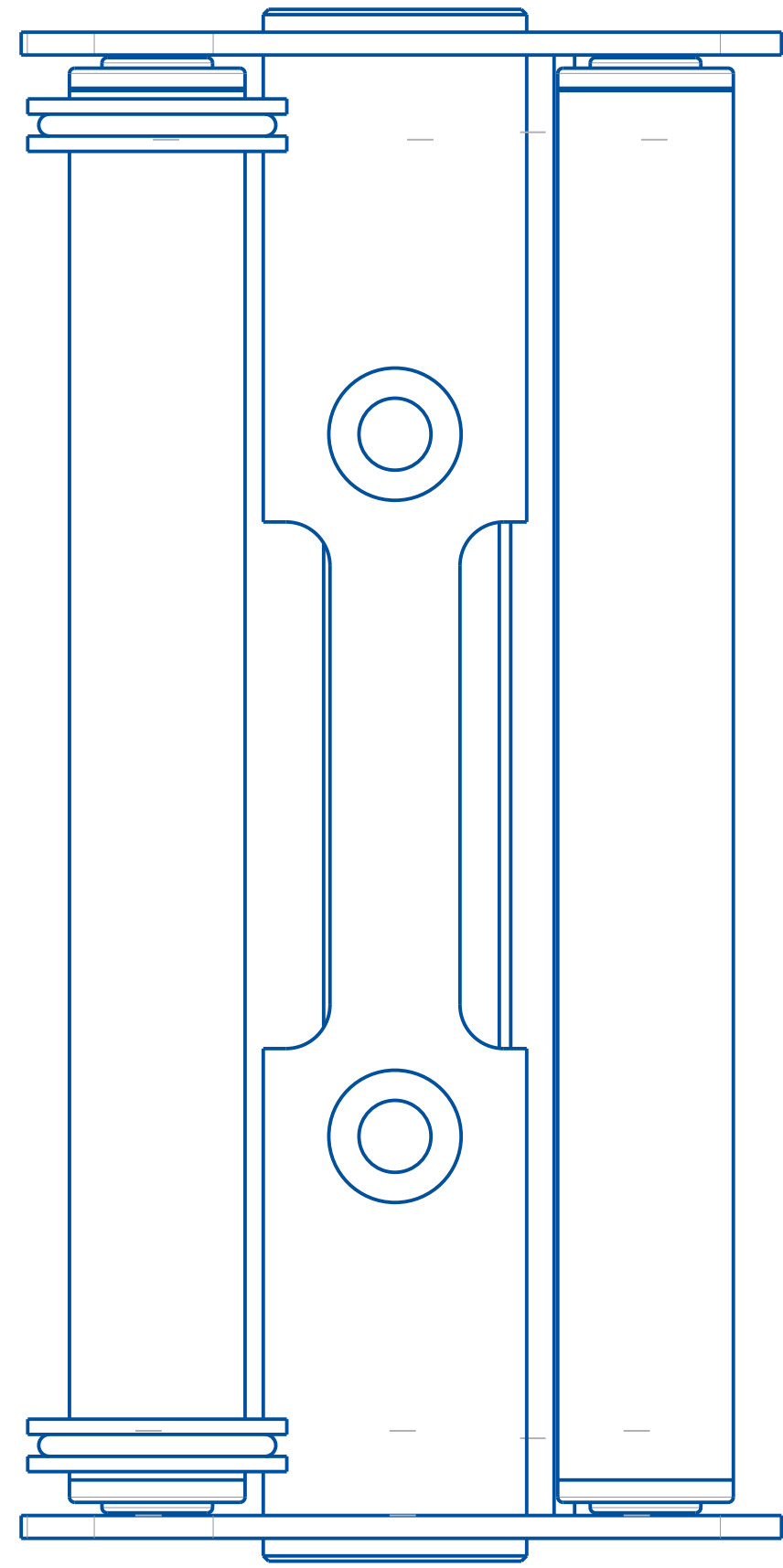

REV	DATE	DESCRIPTION	BY
B	12-FEB-2024	UPDATE DRAWING AND BOM	CRT
A	02/27/2006	NEW DRAWING	SEM

THIS IS A PRO-ENGINEER DOCUMENT AND MAY NOT BE MODIFIED MANUALLY

UNLESS OTHERWISE SPECIFIED DIMENSIONAL TOLERANCE .X ± .1 .XX ± .01 .XXX ± .005 ANGLES ± 30° SURFACE FINISH 125 BREAK ALL EDGES .005/0.15 CORNER RADIUS .010/0.30	QUADREL LABELING SYSTEMS 7670 JENTHER DRIVE MENTOR, OHIO 44060 (440) 602-4700		SCALE: 1/1 DATE: 02/27/2006 DRW BY: SEM CHK BY: APPR BY:
	7" PEEL PLATE ASSEMBLY		
	MAT'L	BOM 21720-000	21720-000

ASSEMBLY TITLE: FIXED BRUSH IMPRESSER

DRAWING NO.:

GENERAL FUNCTION:

- The fixed roller impresser is an option used in applications where a secondary wipe down or label wipe is necessary.

SET UP AND ADJUSTMENTS:

- When installed, the brush assembly will be mounted by an adjustable clamp. The mounting assembly is fastener to the option rail located on the peel plate side wall.
- Four axis of adjustment is available by loosening the set screw locking the roller arm in place.
- Locate the brush as necessary and re-tighten the clamping screws.
- Run a product through the brush area and insure the brush layed on the product but do not impede product travel. The brush can be adjusted too close to the product which will prevent the product from smoothly traversing through the brush area.

MAINTENANCE:

- Keep the brush free of label flash, glue and debris. This will prevent jamming and web tears.

NOTE: Exercise caution when removing bad labels from brush. Careless removal can result in brisals being pull out which may leave the labeler inoperable until the brush is replaced!

TROUBLESHOOTING:

PROBLEM

- Product jams at brush area
- Bubbles in label
- Label edge curling
- Wipedown inadequate

WHAT TO DO

- Increase brush spacing.
- Decrease labeling speed
- Decrease product delay
- Decrease brush spacing.

ITEM	QTY	PART NO.	DESCRIPTION	PARENT ITEM
1	1	801868-000	CLAMPING LEVER	10228-007
2	1	A21264-018	CROSS ARM	10228-007
3	1	A21693-301	IMPRESSOR MOUNTING BLOCK	10228-007
4	1	A23463-100	BRUSH HOLDER	10228-007

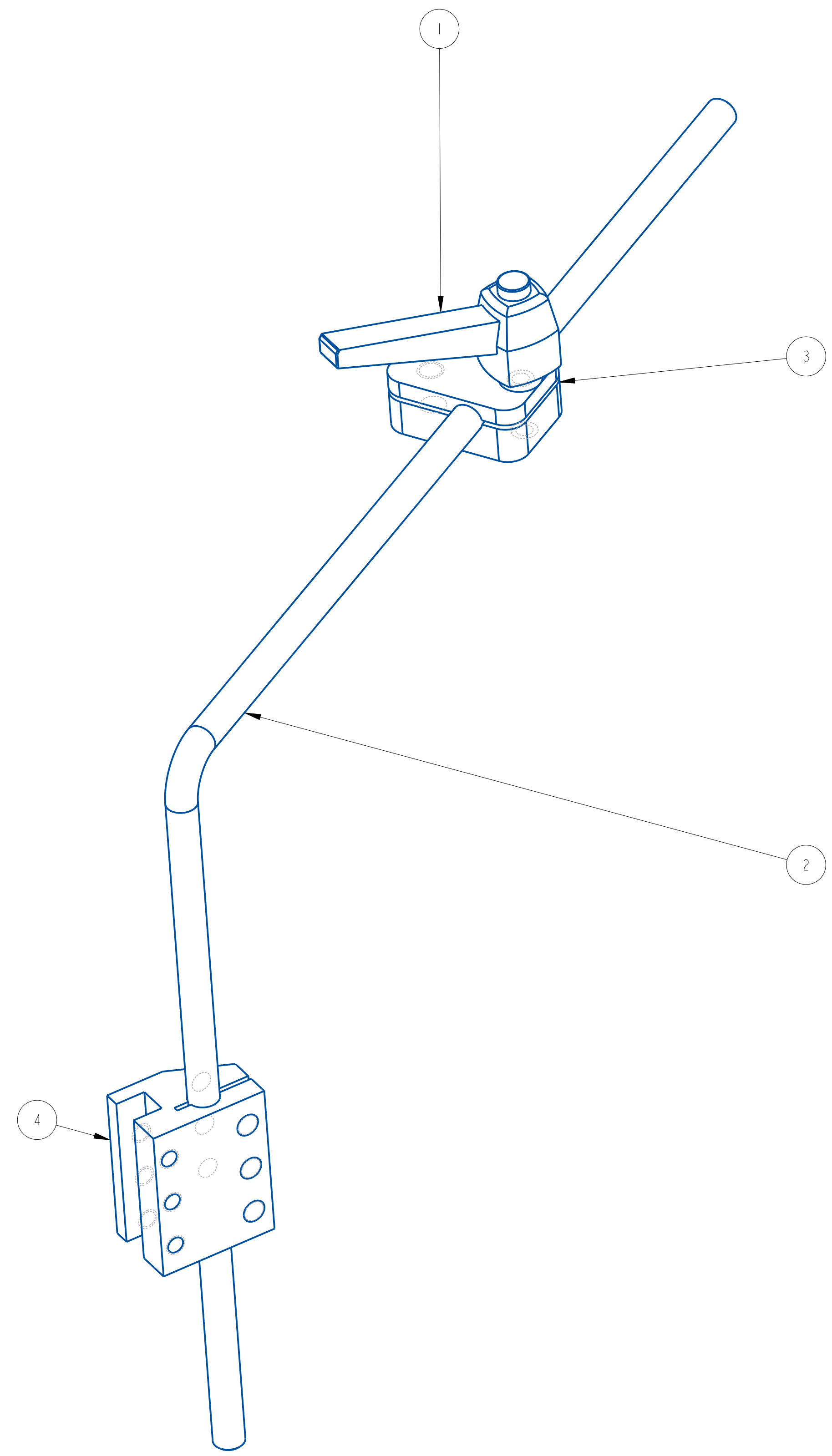

REV	DATE	DESCRIPTION	BY
A	11-13-23	NEW DRAWING	SEM

THIS IS A PRO-ENGINEER DOCUMENT AND MAY NOT BE MODIFIED MANUALLY

UNLESS OTHERWISE SPECIFIED DIMENSIONAL TOLERANCE .x ± .1 .xx ± .01 .xxx ± .005 ANGLES ± 30° SURFACE FINISH 125 BREAK ALL EDGES .005/0.15 CORNER RADIUS .010/0.30	 QUADREL LABELING SYSTEMS 7670 JENTHER DRIVE MENTOR, OHIO 44060 (440) 602-4700	SCALE: 1/1
		DATE: 11-13-23
		DRW BY: SEM
		CHK BY: 02/23/2024-SEM
HEAVY DUTY IMPRESSOR MOUNTING		APPR BY:
MAT'L		10228-007

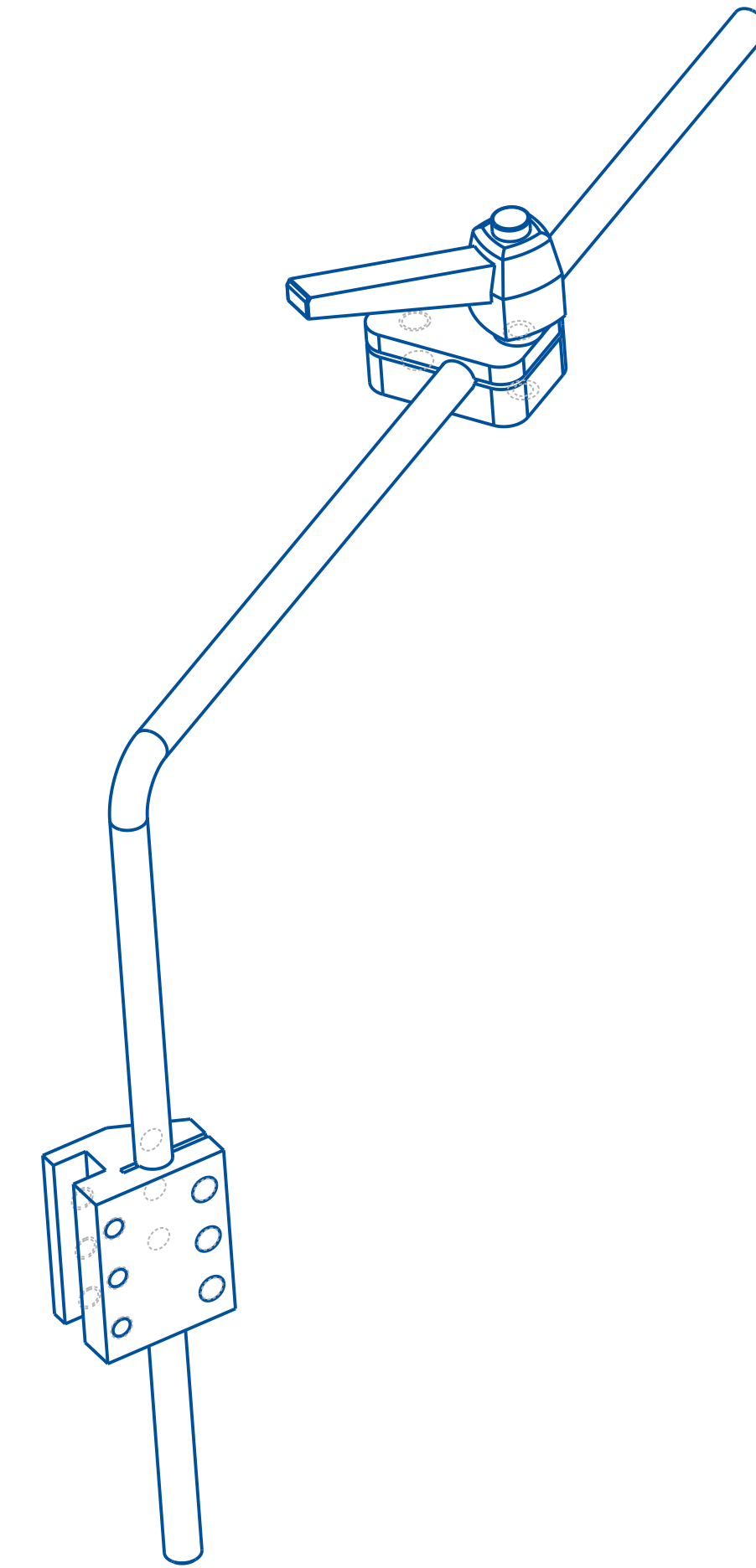
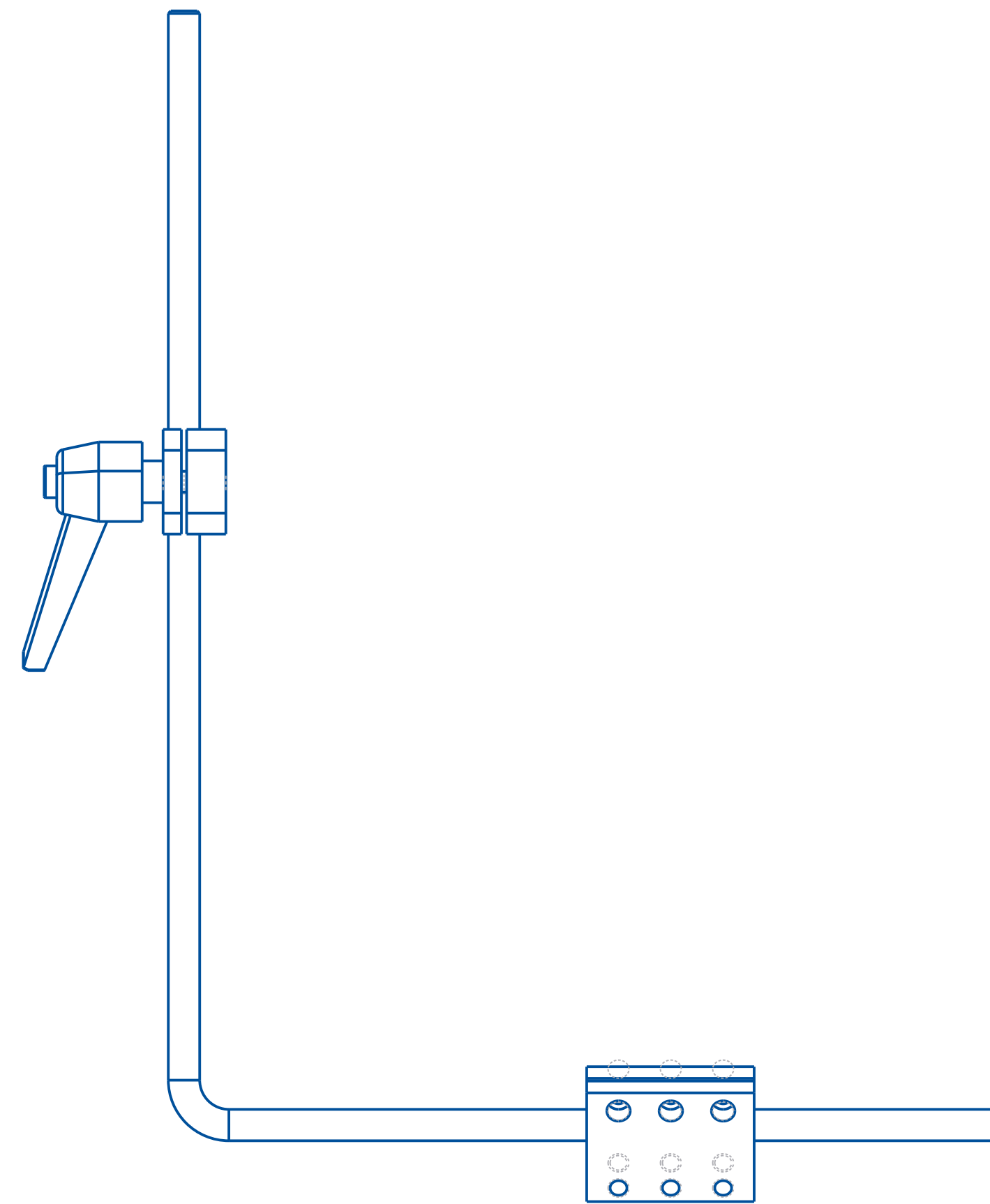
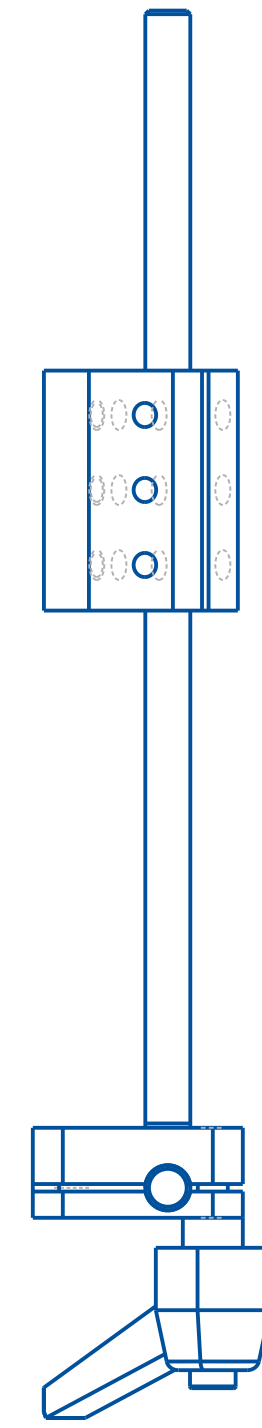

THIS IS A PRO-ENGINEER DOCUMENT AND MAY NOT BE MODIFIED MANUALLY

UNLESS OTHERWISE SPECIFIED	QUADREL LABELING SYSTEMS	SCALE:	5/8
DIMENSIONAL TOLERANCE	7670 JENTHER DRIVE	DATE:	11-13-23
X ± .1	MENTOR, OHIO 44060	DRW BY:	SEM
XX ± .01	(440) 602-4700	CHK BY: 02/23/2024-SEM	
XXX ± .005		APPR BY:	
ANGLES ± .30°			
SURFACE FINISH 125			
BREAK ALL EDGES .005/ .015			
CORNER RADIUS .010/ .030			
ALL ANGLES ARE 90°			

HEAVY DUTY IMPRESSOR MOUNTING

MAT'L 10228-007

A	11-13-23	NEW DRAWING	SEM
REV	DATE	DESCRIPTION	BY

ASSEMBLY TITLE:

Q120 DRIVE AND PINCH ROLL ASSEMBLY

GENERAL FUNCTION:

- The drive roll pulls the liner through the entire labeling head. As the liner is pulled over the peel edge, the label dispenses.
- The spring-loaded pinch roll squeezes the liner against the drive roll to provide positive drive.
- The primary roll is the pull or drive roll as shown. The knurl roll provides a constant pressure against the pull roll.

SET UP AND ADJUSTMENTS:

- When threading the labeling head, use the pinch roll lever to release the pinch roll from the drive roll.
- Use the spring plunger adjustment screws to adjust the contact pressure between the knurl and pull rollers.
- The pressure should be adjusted as tight as necessary to prevent a loose liner, while still allowing full rotation of the pressure release arm.

MAINTENANCE:

- Clean all parts that may have acquired label or glue residue

TROUBLESHOOTING:

PROBLEM

- Meter pulley rubbing against side plate
- Web slips
- Drive roll not rotating when stepping motor rotates
- Pinch roll not providing enough pressure against drive roll
- Drive roll unevenly worn causing tracking problem

WHAT TO DO

- Center pulley on motor shaft and tighten two (2) set screws in pulley.
- Drive roller not closed. Turn drive roll arm to closed position.
- Replace timing belt from motor to drive roll
- Replace pinch roll spring
- Increase tension on drive roll by adjusting spring loaded locking pins.
- Replace drive roll



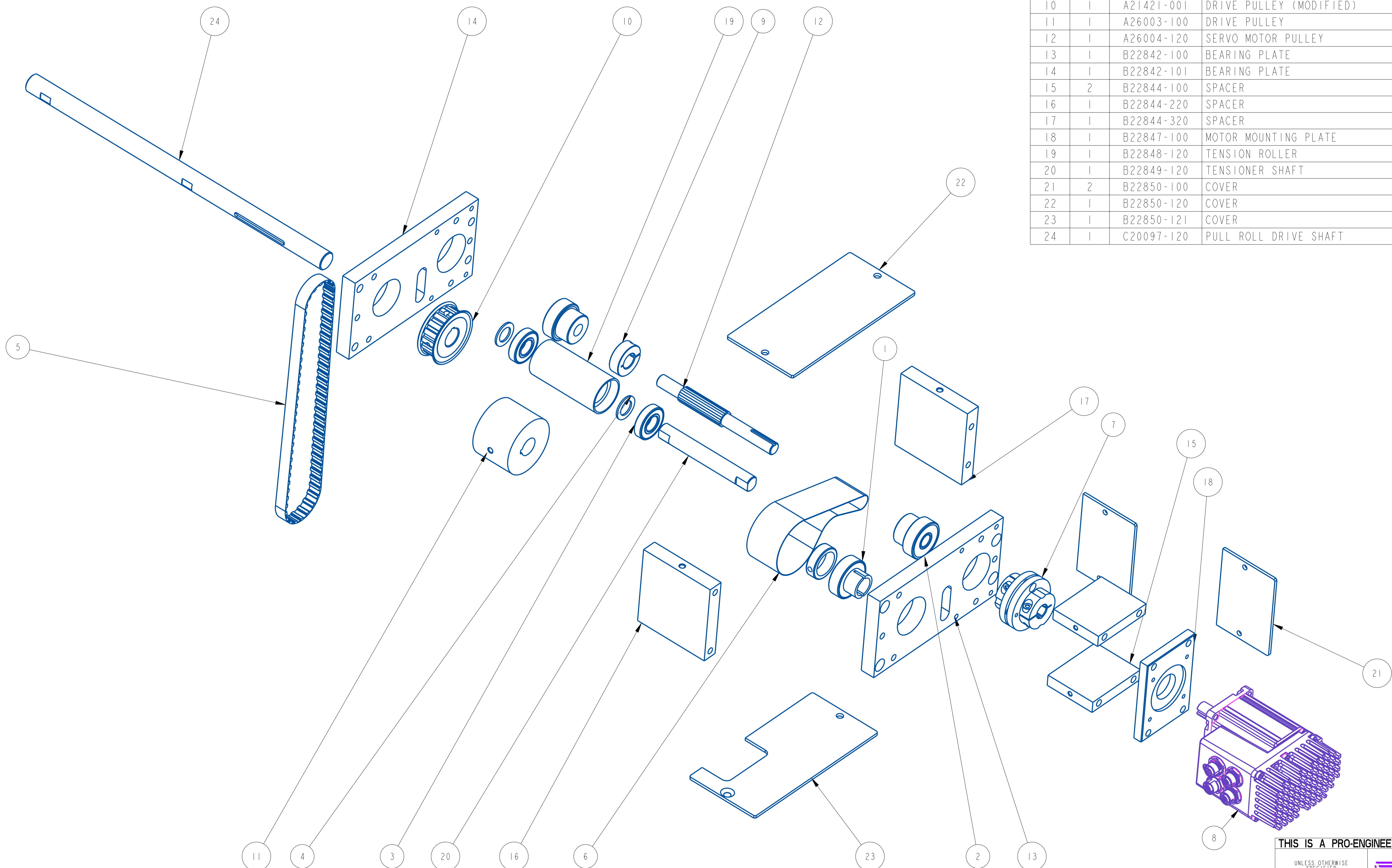

ITEM	QTY	PART NO.	DESCRIPTION	PARENT ITEM
1	1	111044-000	BEARING, 3/4 ID CLAMP TYPE	23125D-017LH_
2	2	111072-100	BEARING BALL, LOCKING COLLAR .5" IDx1.574" OD	23125D-017LH_
3	2	111075-000	BEARING, BALL	23125D-017LH_
4	2	151008-000	BEARING, THRUST WASHER	23125D-017LH_
5	1	191592-000	BELT, TIMING, 1/2P	23125D-017LH_
6	1	192503-150	TIMING BELT	23125D-017LH_
7	1	363159-000	SERVO COUPLING-1/2"BORE & KEY 14 MM BORE	23125D-017LH_
8	1	412495-000	SERVO MOTOR/DRIVE, 60mm	23125D-017LH_
9	1	A20595-120	COLLAR REWORK	23125D-017LH_
10	1	A21421-001	DRIVE PULLEY (MODIFIED)	23125D-017LH_
11	1	A26003-100	DRIVE PULLEY	23125D-017LH_
12	1	A26004-120	SERVO MOTOR PULLEY	23125D-017LH_
13	1	B22842-100	BEARING PLATE	23125D-017LH_
14	1	B22842-101	BEARING PLATE	23125D-017LH_
15	2	B22844-100	SPACER	23125D-017LH_
16	1	B22844-220	SPACER	23125D-017LH_
17	1	B22844-320	SPACER	23125D-017LH_
18	1	B22847-100	MOTOR MOUNTING PLATE	23125D-017LH_
19	1	B22848-120	TENSION ROLLER	23125D-017LH_
20	1	B22849-120	TENSIONER SHAFT	23125D-017LH_
21	2	B22850-100	COVER	23125D-017LH_
22	1	B22850-120	COVER	23125D-017LH_
23	1	B22850-121	COVER	23125D-017LH_
24	1	C20097-120	PULL ROLL DRIVE SHAFT	23125D-017LH_

REV	DATE	DESCRIPTION	BY
A	10/13/25	NEW DRAWING	SEM

THIS IS A PRO-ENGINEER DOCUMENT AND MAY NOT BE MODIFIED MANUALLY

QUADREL LABELING SYSTEMS
 7670 JENTHER DRIVE
 MENTOR, OHIO 44060
 (440) 602-4700

SCALE: 1/2
 DATE: 10/13/25
 DRW BY: SEM
 CHK BY:
 APPR BY:

Q60 7" SERVO DRIVE & REWIND, LHH

MAT'L: 23125D-017LH_

UNLESS OTHERWISE SPECIFIED
 DIMENSIONAL TOLERANCE
 .X ± .1
 .XX ± .01
 .XXX ± .005
 ANGLES ± .30°
 SURFACE FINISH 125
 BREAK ALL EDGES .005/.015
 CORNER RADIUS .010/.030
 ALL ANGLES ARE 90°

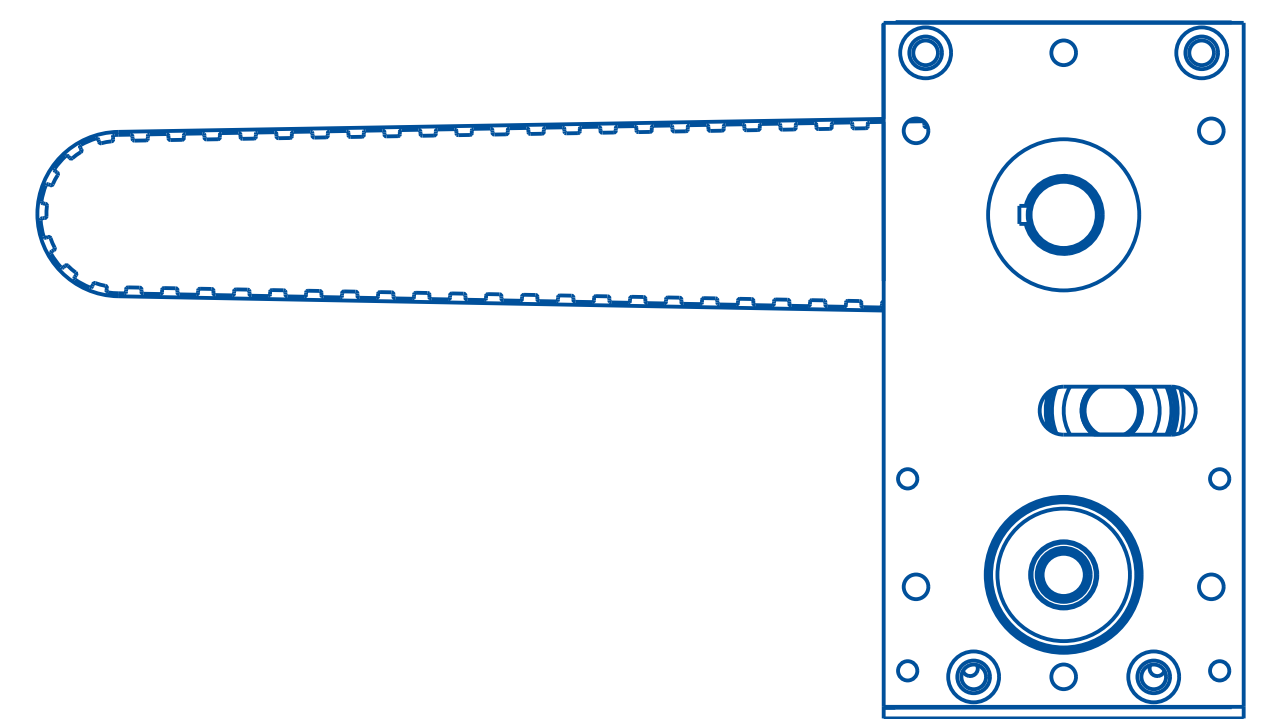
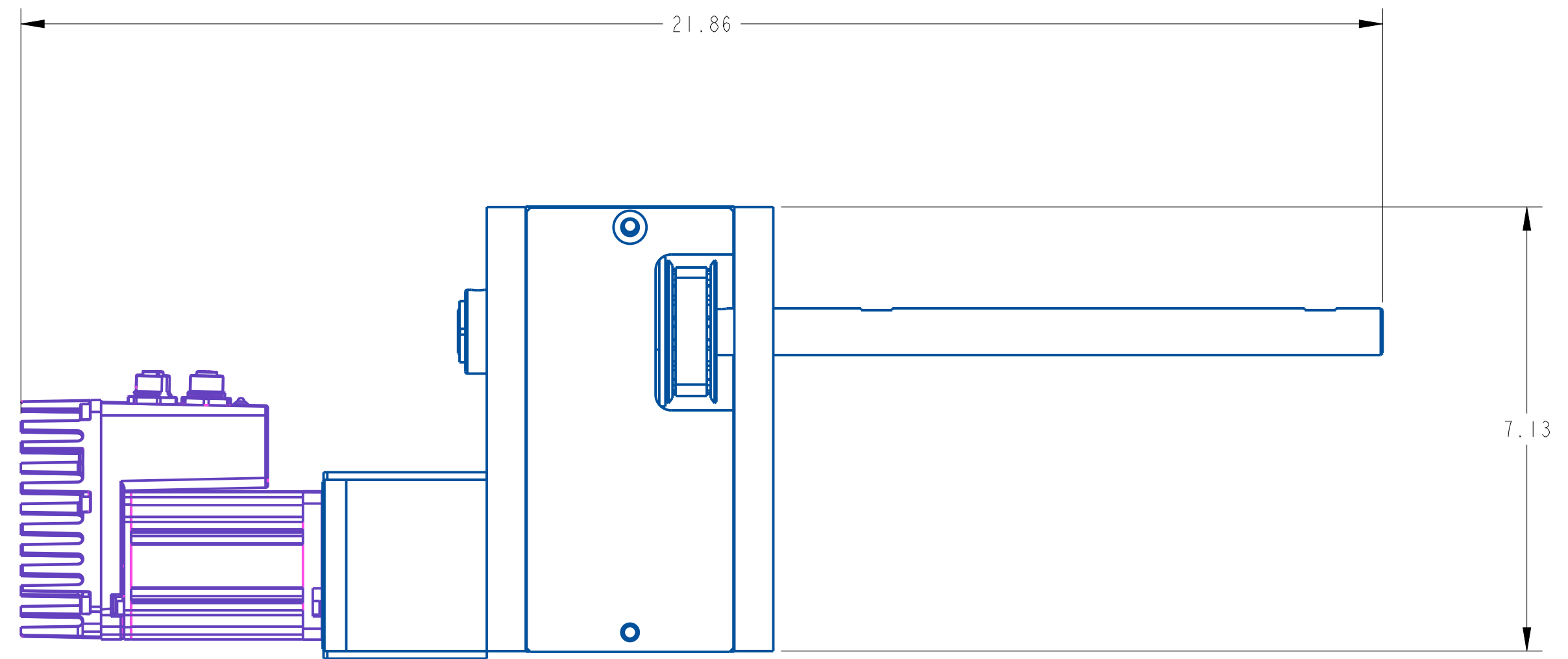
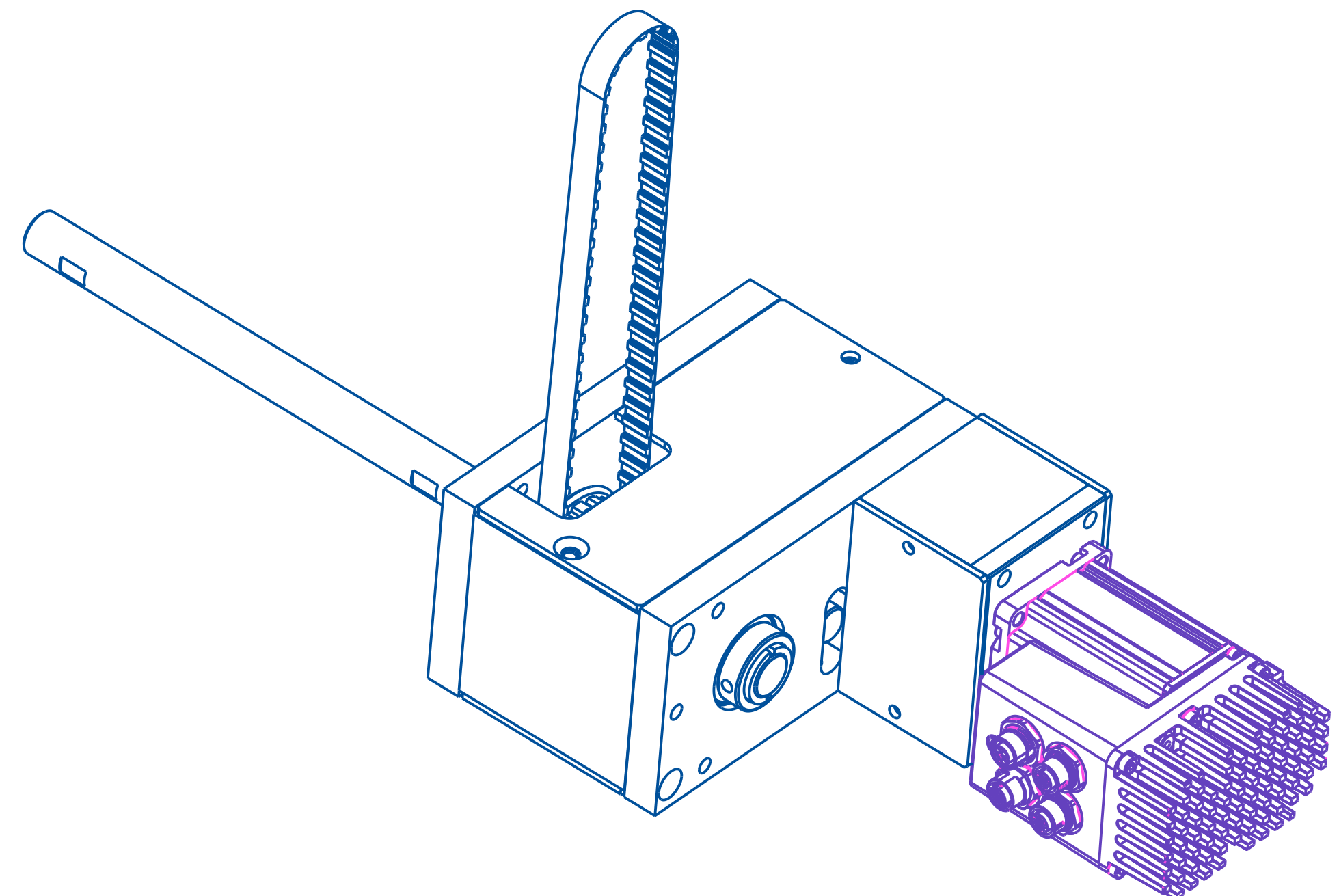
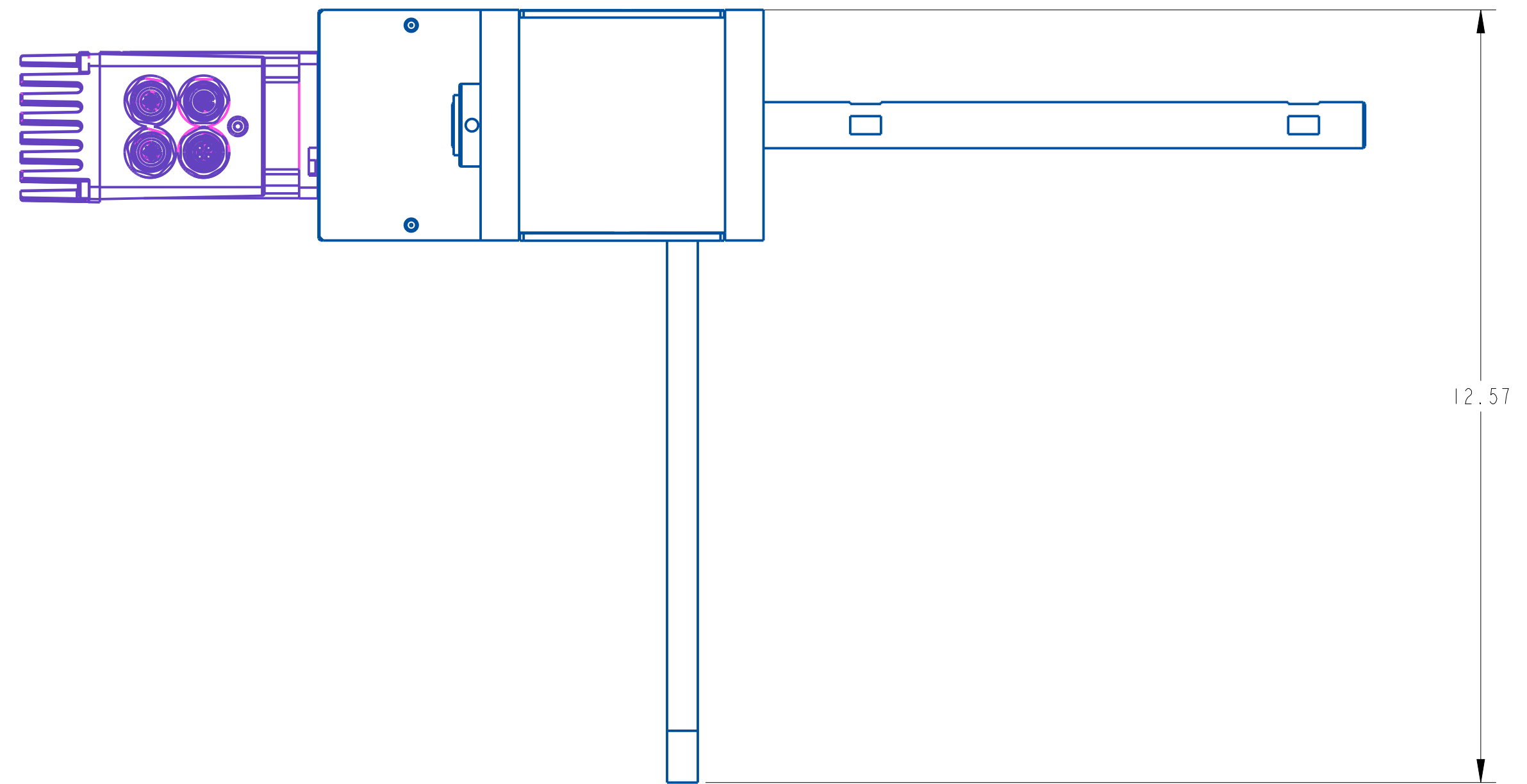

THIS IS A PRO-ENGINEER DOCUMENT AND MAY NOT BE MODIFIED MANUALLY

REV	DATE	DESCRIPTION	BY
A	10/13/25	NEW DRAWING	SEM

UNLESS OTHERWISE SPECIFIED
 DIMENSIONAL TOLERANCE
 .x ± .1
 .xx ± .01
 .xxx ± .005
 ANGLES ± .30°
 SURFACE FINISH 125
 BREAK ALL EDGES .005/.015
 CORNER RADIUS .010/.030
 ALL ANGLES ARE 90°

QUADREL LABELING SYSTEMS
 7670 JENTHER DRIVE
 MENTOR, OHIO 44060
 (440) 602-4700

SCALE: 1/2
 DATE: 10/13/25
 DRW BY: SEM
 CHK BY:
 APPR BY:

Q60 7" SERVO DRIVE & REWIND, LHH

MAT'L

23125D-017LH_

ITEM	QTY	PART NO.	DESCRIPTION	PARENT ITEM
1	2	00301-17	SPRING, .275 x .052 x .94	23100DR-007LH
2	2	111052-000	BEARING	23100DR-007LH
3	2	111072-000	BEARING, BALL	23100DR-007LH
4	2	151004-000	BEARING, THRUST WASHER	23100DR-007LH
5	1	362161-000	COLLAR, SETSCREW, 1/2 IN. ID	23100DR-007LH
6	2	A20567-000	WHITE NYLON SLUG	23100DR-007LH
7	1	A21750-000	PINCH POINT GUARD ROD	23100DR-007LH
8	1	A23125-000	SPACER	23100DR-007LH
9	1	A23751-000	SPACER	23100DR-007LH
10	1	A23752-000	SPACER	23100DR-007LH
11	1	A25249-000	INDEX DOT	23100DR-007LH
12	1	A25250-000	IND KNOB	23100DR-007LH
13	1	B20125-001	KNURLED ROLL SHAFT,	23100DR-007LH
14	1	B20126-001	KNURLED ROLL	23100DR-007LH
15	1	B20137-002	PULL ROLL, 7"	23100DR-007LH
16	1	B21614-000	YOKE OUTSIDE PLATE	23100DR-007LH
17	1	B21615-000	YOKE INSIDE PLATE	23100DR-007LH
18	1	B21616-001	YOKE FILLER BAR	23100DR-007LH

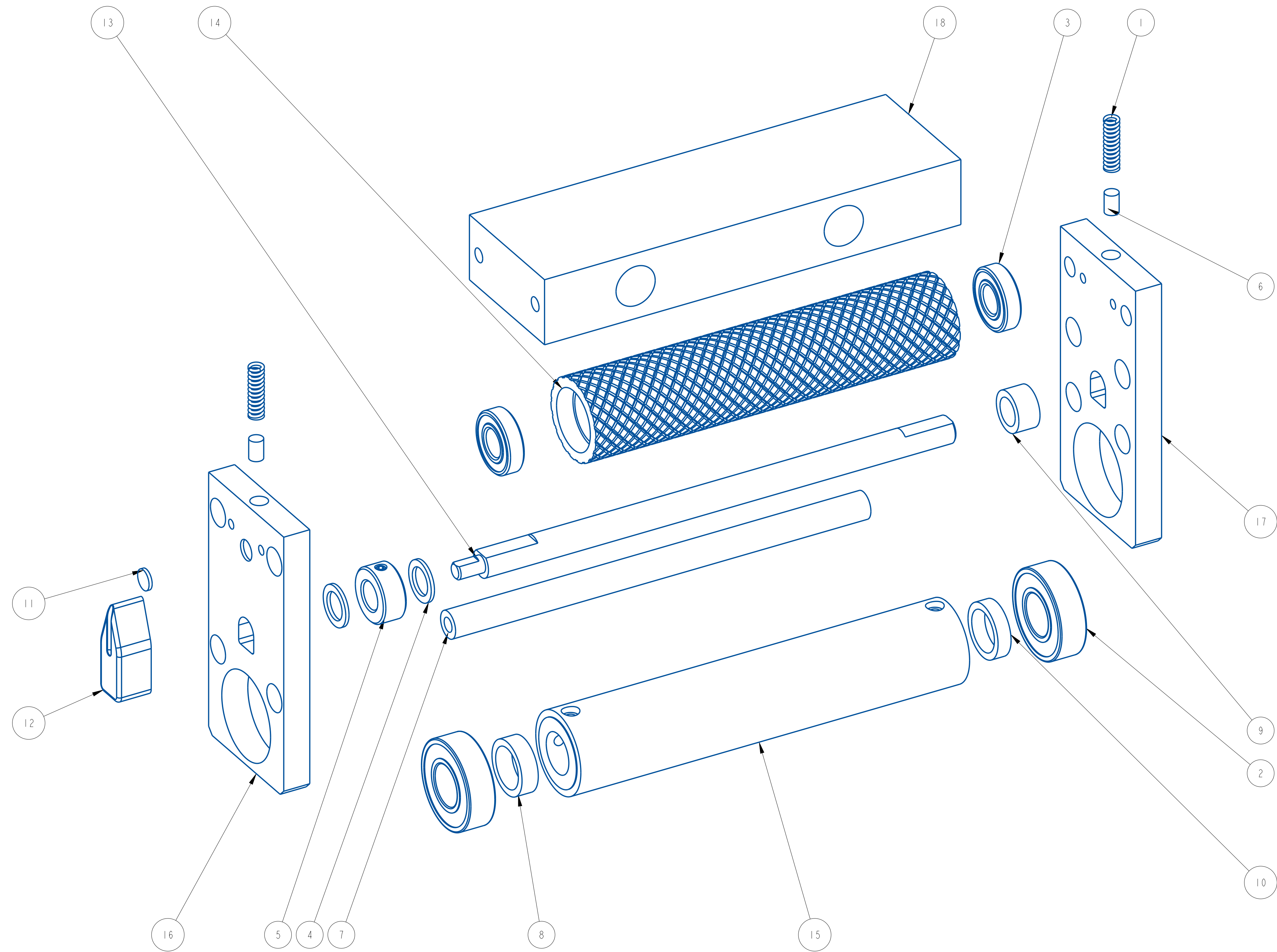

REV	DATE	DESCRIPTION	BY
A	10/13/25	NEW DRAWING	RDL

THIS IS A PRO-ENGINEER DOCUMENT AND MAY NOT BE MODIFIED MANUALLY

QUADREL LABELING SYSTEMS
 7670 JENTHER DRIVE
 MENTOR, OHIO 44060
 (440) 602-4700

SCALE: 1/1
 DATE: 10/13/25
 DRW BY: RDL
 CHK BY: 10/13/2025-SEM
 APPR BY:

DRIVE ASSEMBLY, 7" LHH

MAT'L: 23100DR-007LH

UNLESS OTHERWISE SPECIFIED
 DIMENSIONAL TOLERANCE
 .X ± .1
 .XX ± .01
 .XXX ± .005
 ANGLES ± 30°
 SURFACE FINISH 125
 BREAK ALL EDGES .005/0.15
 CORNER RADIUS .010/0.30

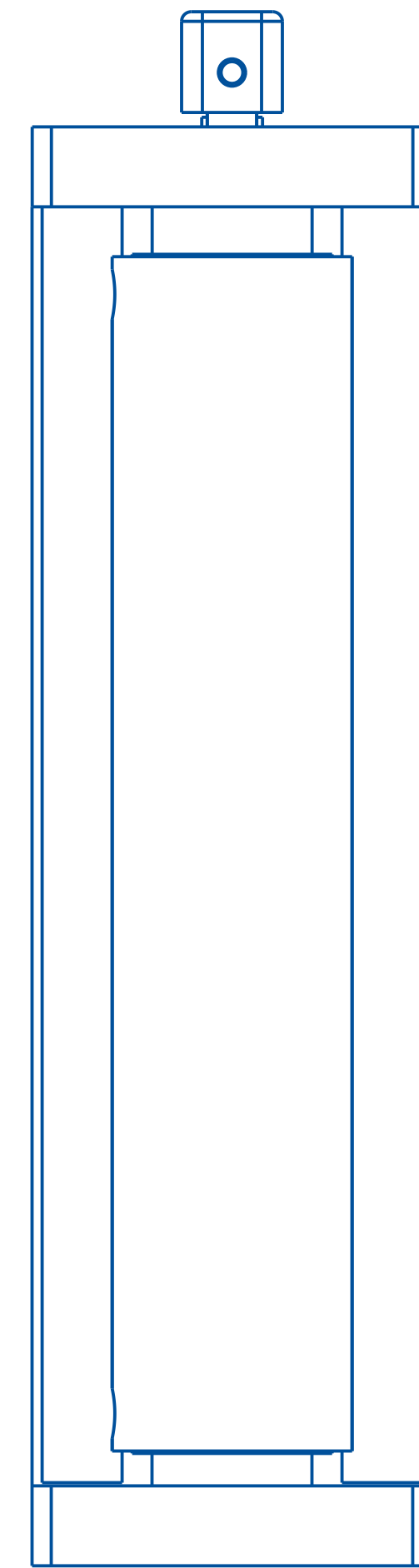
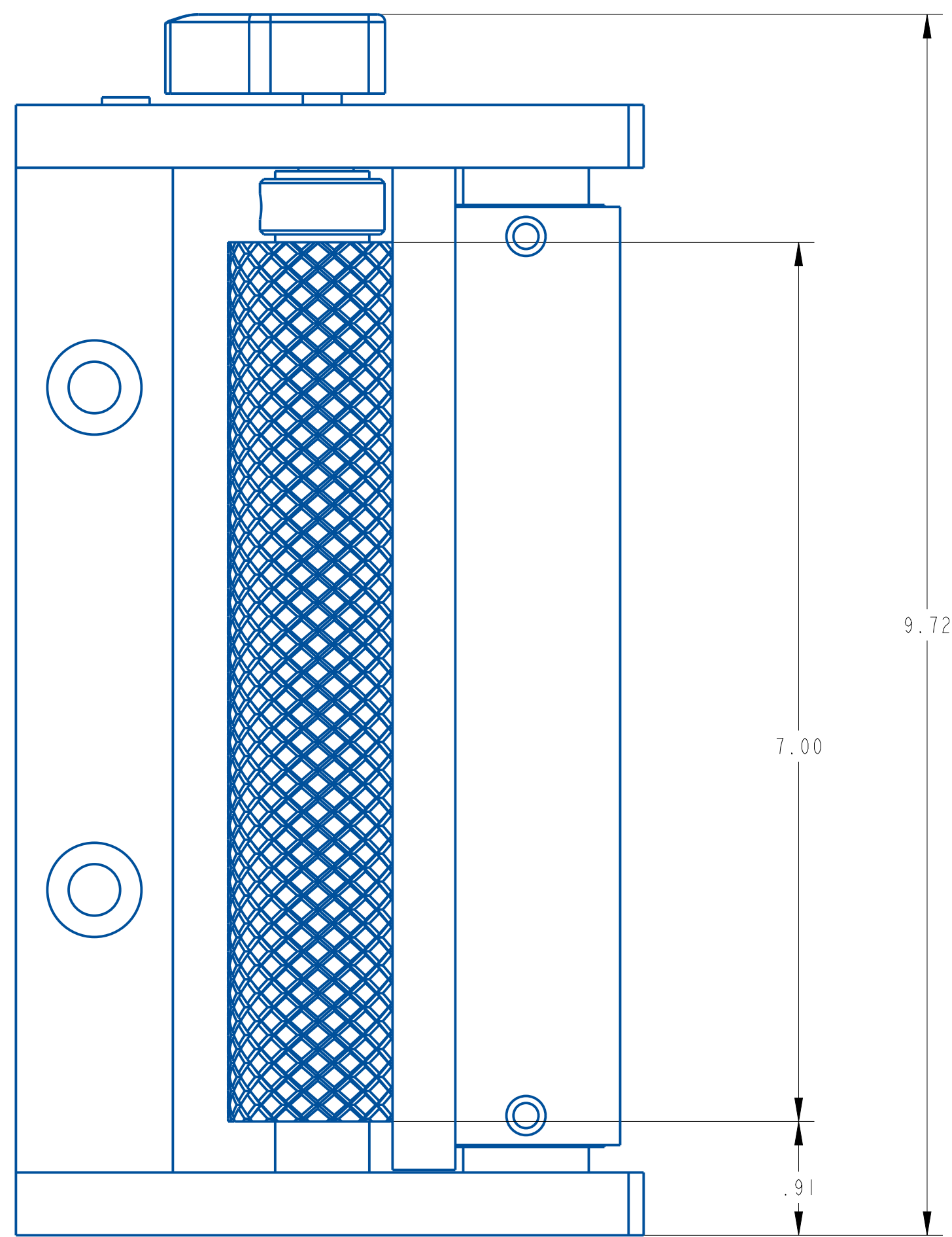
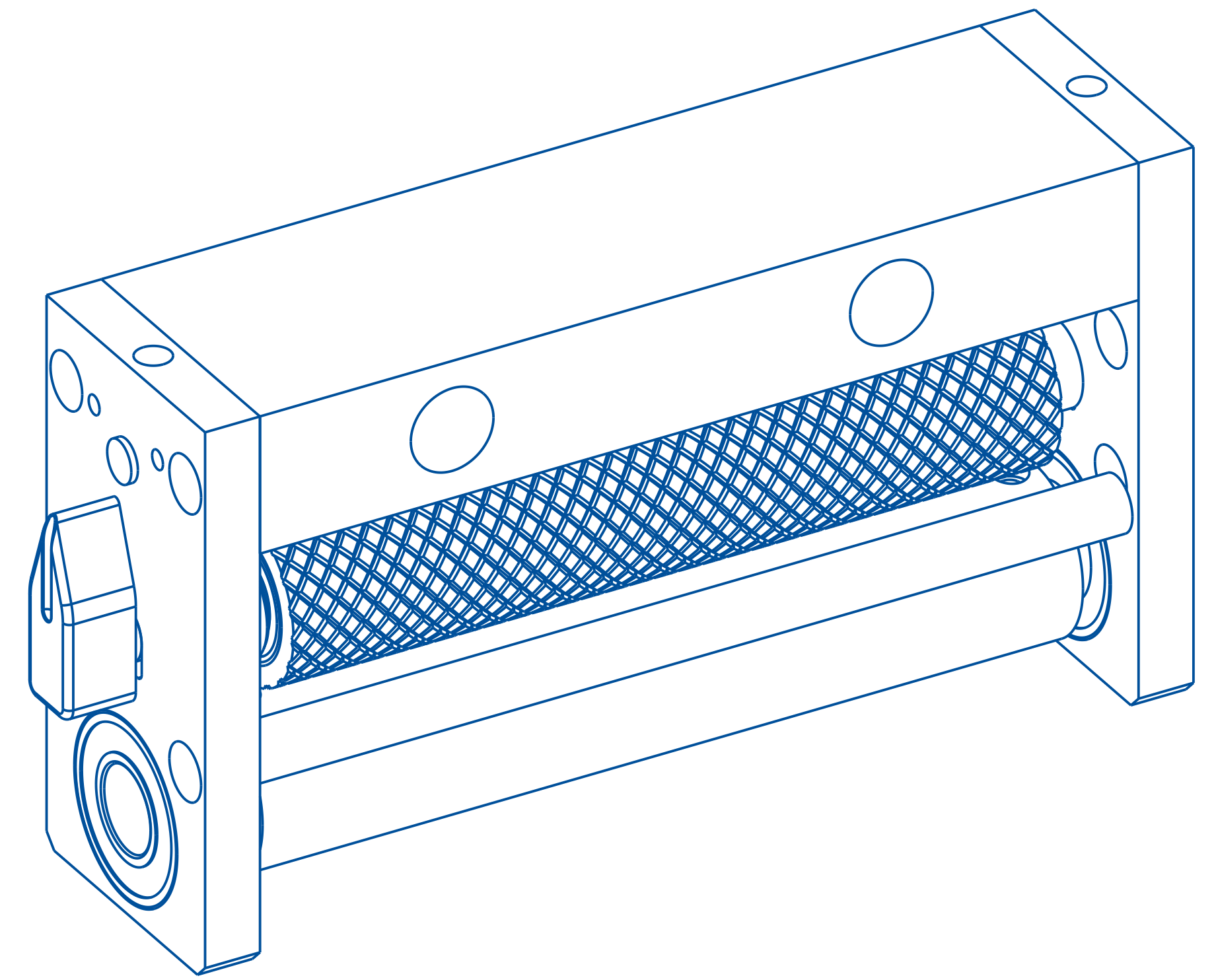
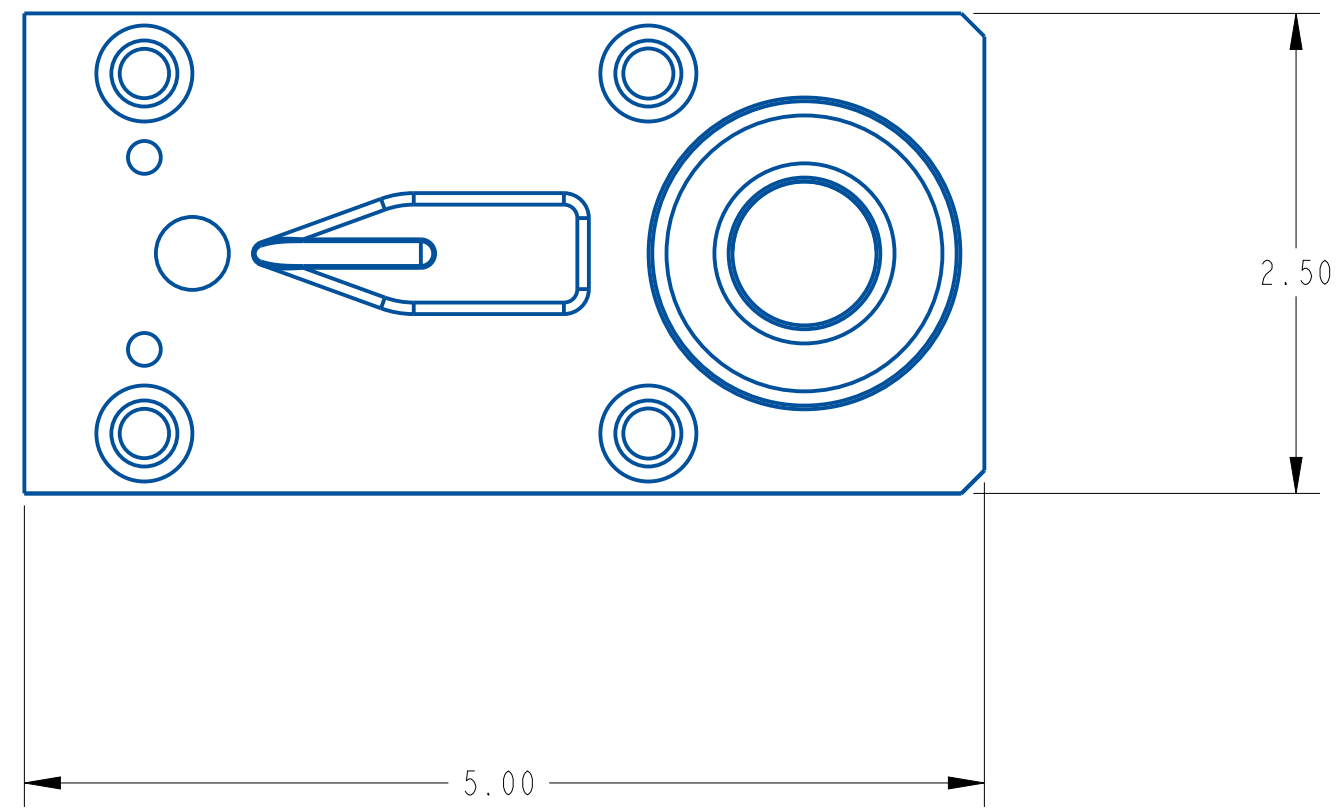

REV	DATE	DESCRIPTION	BY
A	10/05/25	NEW DRAWING	RDL

THIS IS A PRO-ENGINEER DOCUMENT AND MAY NOT BE MODIFIED MANUALLY

UNLESS OTHERWISE SPECIFIED DIMENSIONAL TOLERANCE	.x ± .1 .xx ± .01 .xxx ± .005 ANGLES ± .30°	SURFACE FINISH 125 BREAK ALL EDGES .005/ .015 CORNER RADIUS .010/ .030 ALL ANGLES ARE 90°	QUADREL LABELING SYSTEMS 7670 JENTHER DRIVE MENTOR, OHIO 44060 (440) 602-4700	SCALE: 1/1 DATE: 05-OCT-15 DRW BY: RDL CHK BY: 10/13/2025-SEM APPR BY:
---	--	--	---	--

DRIVE ASSEMBLY, 7" LHH

MAT'L	23100DR-007LH
-------	---------------

Servo Belt Removal & Installation

Remove the clear cover on the side of the coupling of the servo motor. Then loosen the 4 5/16-18 socket heads holding the motor mounting plate to the spacer blocks. (Shown in image on the right)



Loosen the 2 bolts on the coupling. Then remove the motor and coupling assembly. (Shown in image on the left)

Loosen the tension on the servo belt by removing loosening the 2 jam nuts on the set screws shown and removing the set screws. (Shown in image on the right)





Loosen set screw in the collar on the end of the drive shaft. Then remove the collar. (Shown in image on the left)

Remove the 4 5/16-18 socket head bolts that hold the bottom plate to the spacer blocks. Then remove the two button head screws holding the lexan cover on and remove cover. (Shown in image on the right)

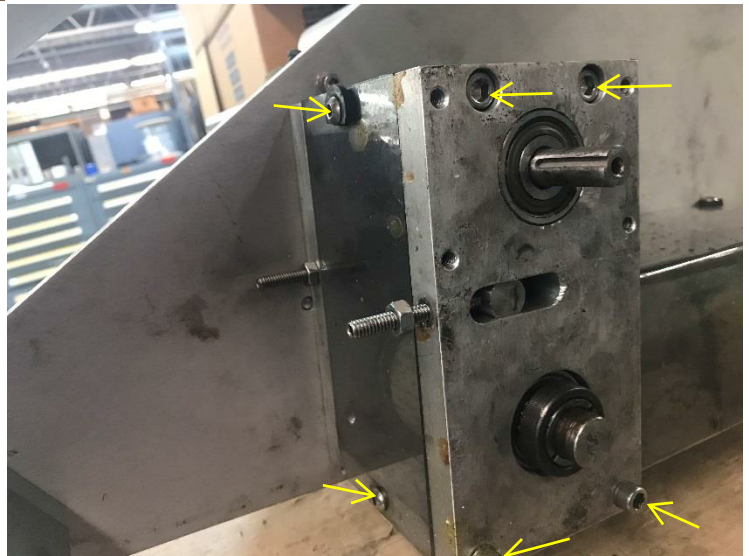

Remove the set screw on the eccentric collar then spin the collar to loosen from shaft. (Shown in image on the left)

Once the bolts are removed, remove the bottom plate. This may take some prying and finessing, be careful to not bend the plate, shafts, or ruin the bearings during the removal of the plate. Once removed clean the plate and bearings. (Shown in image on the right & bottom)



If Equipped

Remove the cover over the rewind kinetrol and other side of the servo belt. (Shown in image on the left)

Remove the tensioner, belt and smaller diameter shaft with the pulley teeth on it. (Shown in image on the right)



Once removed clean all surfaces shafts bearing and check the rewind belt for cracks or uneven wear. You can use a scotch brite pad the clean up the shafts and ect. (Shown in image on the left)

Check the lock collar on the shaft with the pulley grooves ensure the collar is tight and the stack up is correct. The washer goes on top of the collar and shall be flush with the end of the pulley grooves as shown in the image below. Slide the collar over the end of the shaft as shown. This stack up is extremely important.



Ensure your belt is riding properly on the kinetrol pulley. The belt should be running in the middle of the pulley of as close to centered as you can get. Spin the kinetrol and ensure the belt is tracking well. (Shown below)



To adjust this rotate the pulley until you see the set screw. Loosen the set screws and slide the pulley accordingly. Slide the larger pulley down or up as well these pulleys should be together. (Shown in image on the right)



After you have cleaned everything up, checked the rewind belt and properly checked alignment of the pulleys. It is now time to re-assemble. Start by putting the belt in then the tensioner. Ensure the idler has the oil lite washers installed on the top and bottom of the idler. (Shown in the image to the left)

NOTE Blue Loctite is recommended on all fasteners.

Place the eccentric collar over the smaller diameter shaft and slide the bottom servo plate on. Ensure the tensioner is positioned properly in the slot on the bottom plate with the oil lite washer in place. Fasten the plate to the spacer blocks. Once fastened rotate the eccentric collar to lock it into place make sure it is tight this is very important. Lock into place with set screw. (Shown in image below)

NOTE Blue Loctite is recommended on all fasteners.

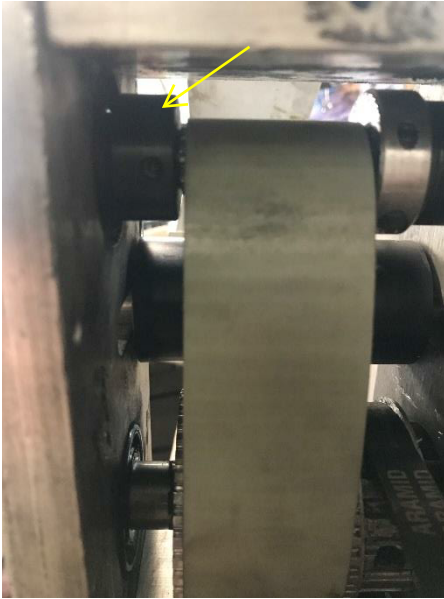

Thread in the set screws evenly to set tension on the belt the belt should not be too tight if you reach around the back you can push against the belt as you tighten it. This is more of a touch setting you do not want the belt to be solid to the touch more like 1/8th - 1/4th inch of travel when you push on the belt. If it is too loose it can skip teeth. When the tension is set lock into place using the jam nuts. (Shown in image below)

NOTE Do NOT loctite set screws for the tensioner.

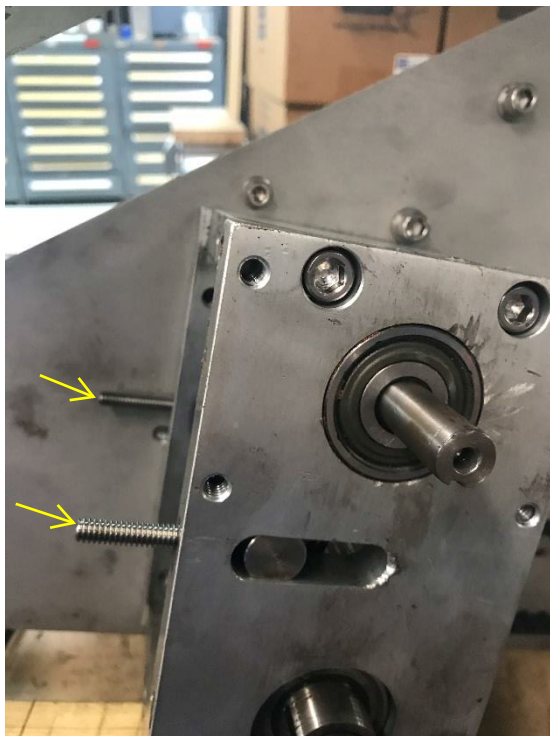

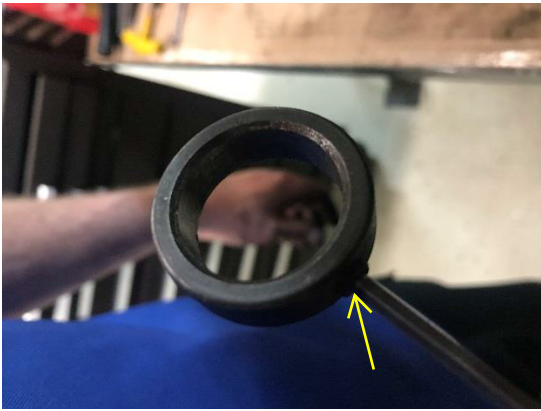

Fasten the collar to the end of the larger diameter shaft as shown.

NOTE Blue Loctite is recommended on all fasteners.

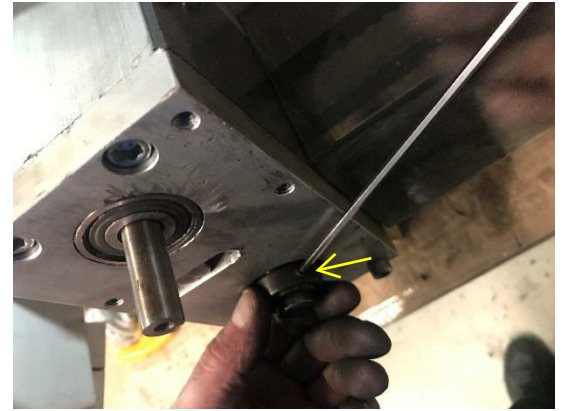

Place the lexan covers on the 2 sides of the servo belt assembly and the cover over the rewind kinetrol assembly. Make sure the fasteners has blue Loctite and rubber grommets. (Shown in image on the left)

Place the servo motor coupling over the end of the smaller diameter shaft. Fasten the motor mounting assembly to the bottom plate using blue Loctite. Align the coupling centered between the shafts so the coupling has enough to fasten to on each of the shafts. Fasten the coupling to the shafts. Mount the lexan covers make sure the fasteners has blue Loctite and rubber grommets. (Shown in image on the right)

NOTE Blue Loctite is recommended on all fasteners.



ASSEMBLY TITLE:

Q120 REWIND ASSEMBLY

GENERAL FUNCTION:

- The rewind drum rolls up the liner
- The rewind pin, when pulled out, allows the liner to be released from the rewind drum.
- The rewind flange supports and guides the liner.
- The friction clutch allows for slippage to accommodate for varying speeds between the drive roll and rewind drum.
- The adjusting knob controls the torque adjustment of the drum.

SET UP AND ADJUSTMENTS:

- Position the rewind flange slightly below the web path and lock with the set screw in the hub.
- When threading liner to the rewind, place the liner between the drum and pin.
- Tighten adjusting knob just enough to allow the rewind drum to keep up with the drive roll.

NOTE: Excessive tightening will cause the web to be wound very tight, causing difficulty in removal and possible step motor stall.

MAINTENANCE:

- Clean all parts that have acquired label or glue residue
- Replace friction disc when worn out.

TROUBLESHOOTING:

PROBLEM

- Rewind drum not rotating when stepping motor rotates
- Rewind drum not keeping up with drive roll
- Web winding too tight on hub
- Grinding in rewind hub

WHAT TO DO

- Replace timing belt from motor to rewind
- Tighten adjusting knob
- Loosen adjusting knob
- Replace friction disc by removing knob and sliding off rewind drum



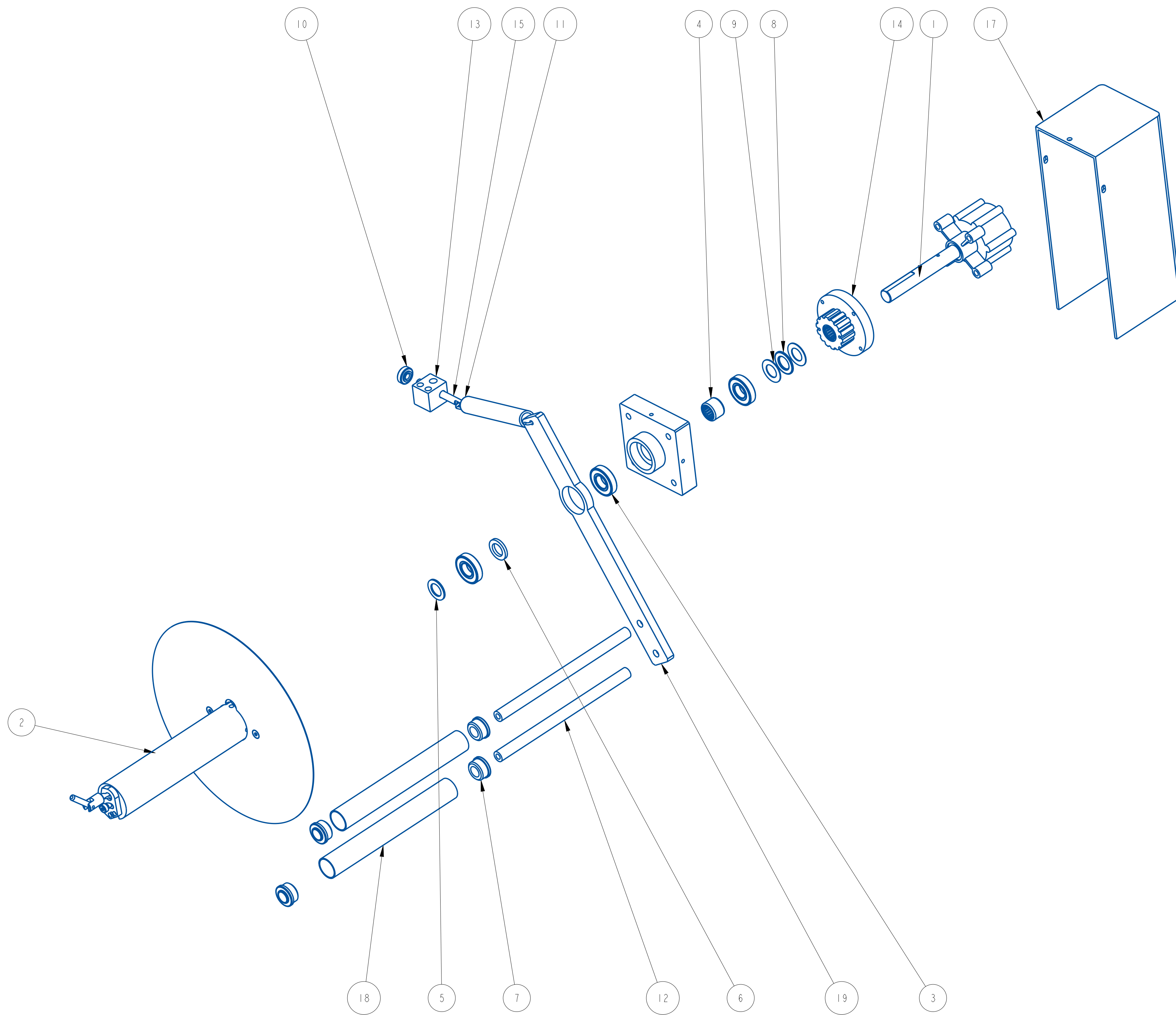

ITEM	QTY	PART NO.	DESCRIPTION	PARENT ITEM
1	1	20499-001	DASHPOT & SHAFT ASSEMBLY	23100R-007LH
2	1	22188-000	7" COLLAPSIBLE REWIND ASSEMBLY	23100R-007LH
3	3	111075-000	BEARING, BALL	23100R-007LH
4	1	121067-000	BEARING, NEEDLE	23100R-007LH
5	1	151008-000	BEARING, THRUST WASHER	23100R-007LH
6	1	151017-000	BEARING, THRUST WASHER	23100R-007LH
7	4	181063-000	BEARING, ROLL END	23100R-007LH
8	1	181081-000	BEARING, NEEDLE ROLLER	23100R-007LH
9	2	181082-000	BEARING, THRUST WASHER	23100R-007LH
10	1	801601-000	CHECK NUT	23100R-007LH
11	1	811216-000	EXTENSION SPRING, STAINLESS	23100R-007LH
12	2	A20928-002	ROLLER SHAFT	23100R-007LH
13	1	A21479-000	SPRING ADJUSTMENT BLOCK	23100R-007LH
14	1	A22120-000	REWIND PULLEY ASSEMBLY	23100R-007LH
15	1	A23131-000	STUD	23100R-007LH
16	1	B20004-007	REWIND BEARING PLATE	23100R-007LH
17	1	B20005-120	GUARD	23100R-007LH
18	2	B20071-003	IDLER ROLLER (DANCER)	23100R-007LH
19	1	C20894-004	REWIND DANCER ARM	23100R-007LH



REV	DATE	DESCRIPTION	BY
A	09/08/25	NEW DRAWING	SEM

THIS IS A PRO-ENGINEER DOCUMENT AND MAY NOT BE MODIFIED MANUALLY

UNLESS OTHERWISE SPECIFIED
DIMENSIONAL TOLERANCE
X ± .1
XX ± .01
XXX ± .005
ANGLES ± 30°

SURFACE FINISH 125
BREAK ALL EDGES .005/0.15
CORNER RADIUS .010/0.30

QUADREL LABELING SYSTEMS
7670 JENTHER DRIVE
MENTOR, OHIO 44060
(440) 602-4700

SCALE: 3/8
DATE: 09/08/25
DRW BY: SEM
CHK BY: 09/08/2025-SEM
APPR BY:

REWIND & DANCER ASSEMBLY w/KINETROL, 7"
MAT'L

23100R-007LH

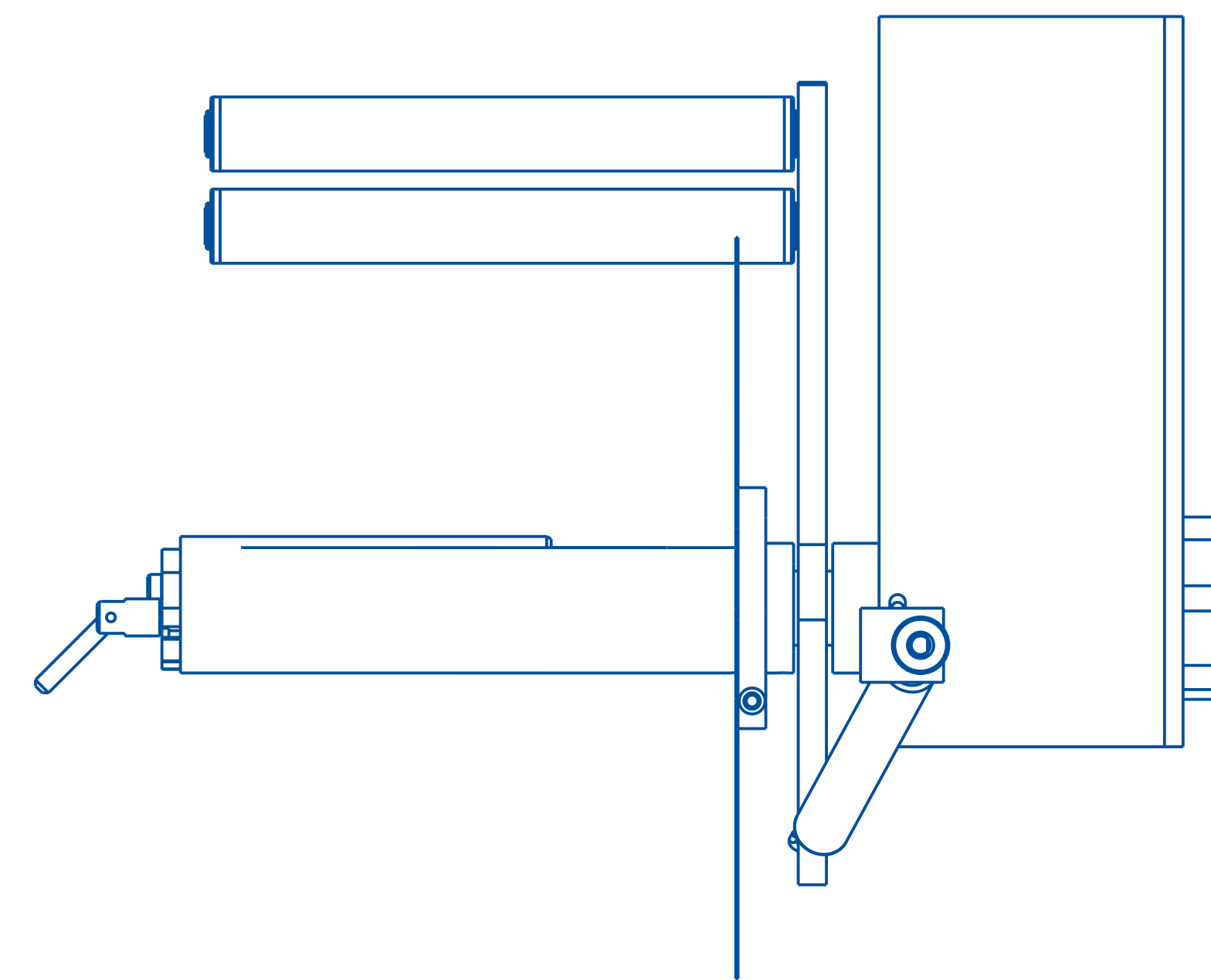
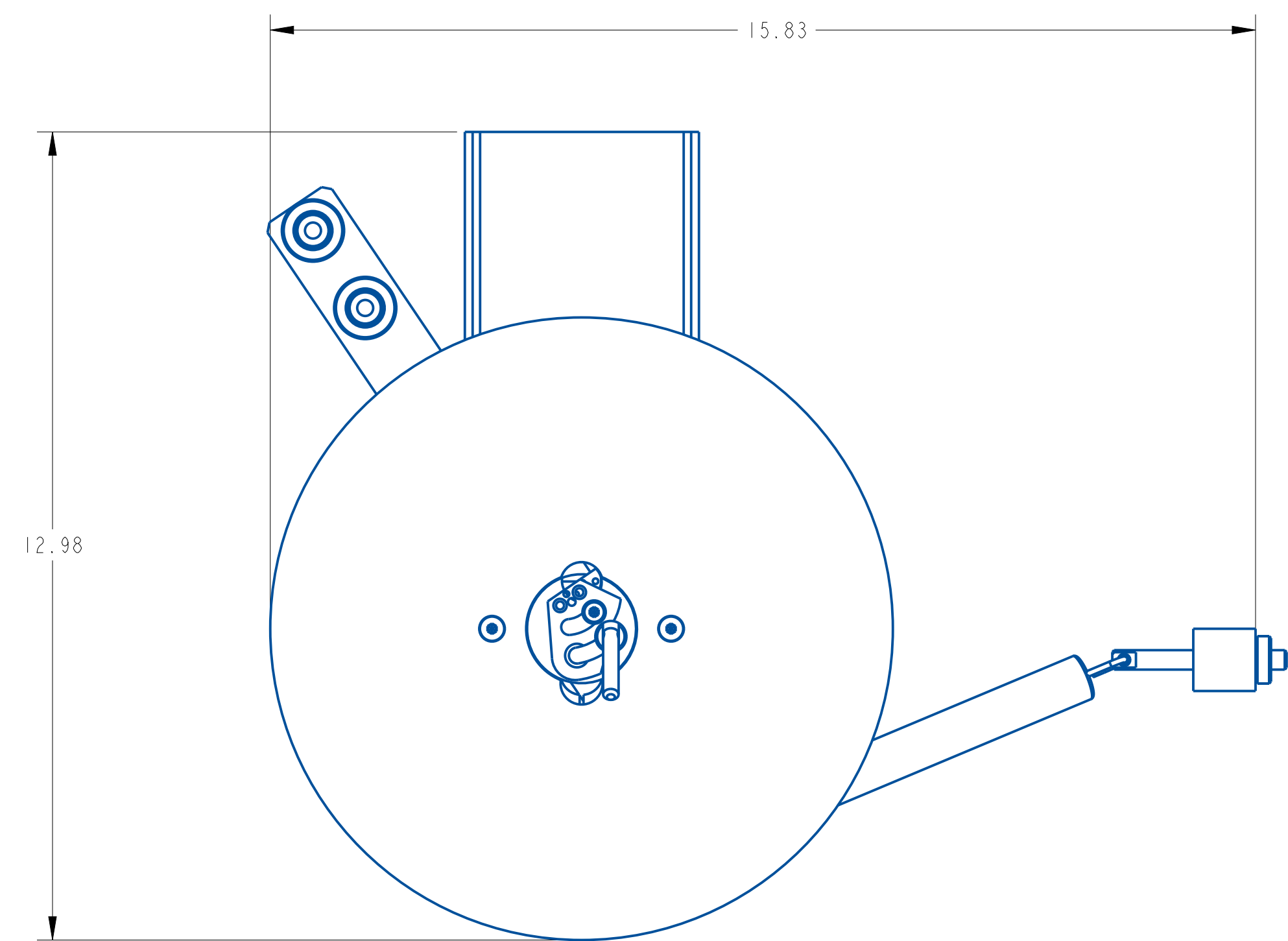
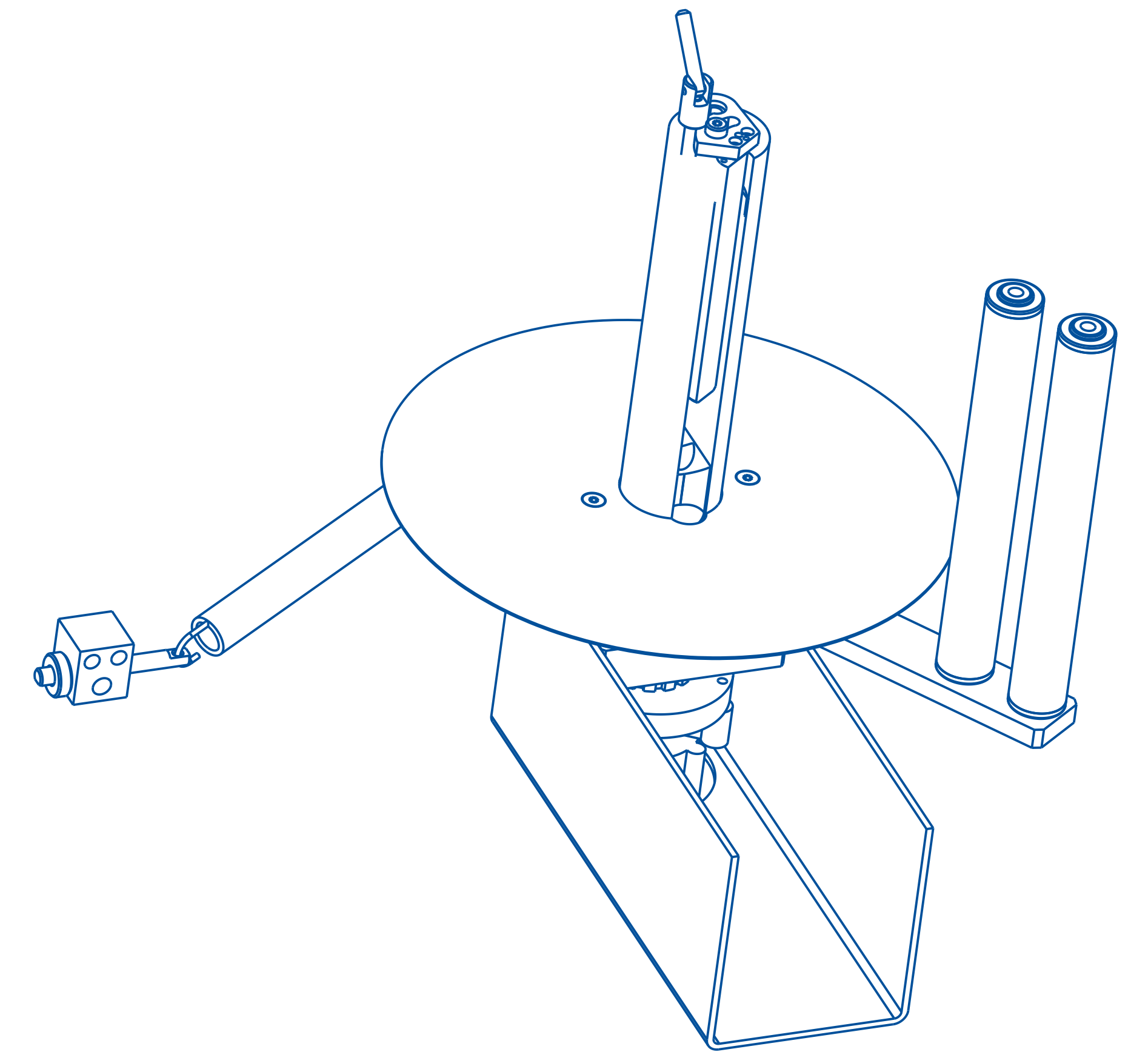
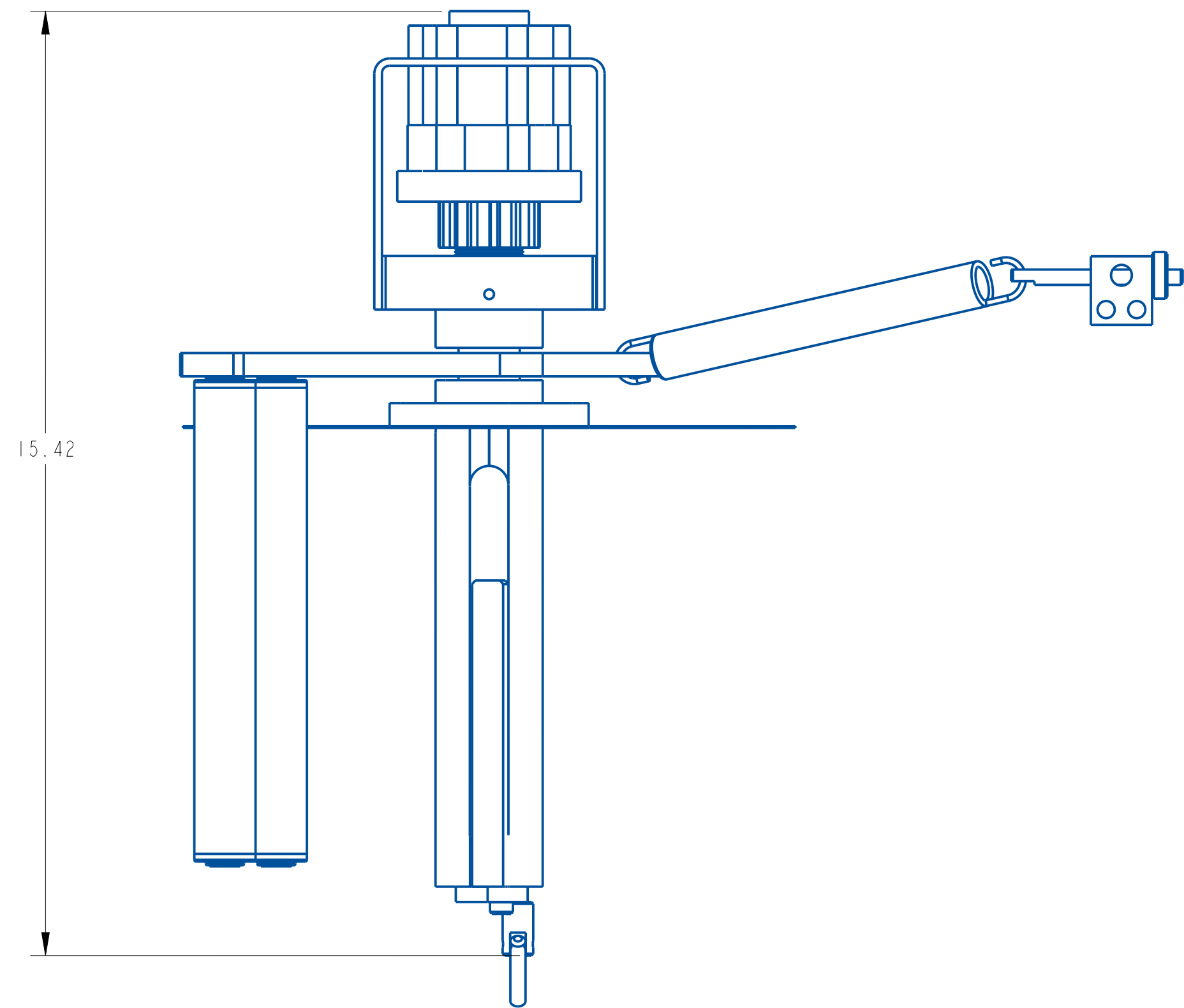

REV	DATE	DESCRIPTION	BY
A	09/08/25	NEW DRAWING	SEM

THIS IS A PRO-ENGINEER DOCUMENT AND MAY NOT BE MODIFIED MANUALLY

UNLESS OTHERWISE SPECIFIED
DIMENSIONAL TOLERANCE
X ± .01
XX ± .005
ANGLES ± .30°
SURFACE FINISH 125
BREAK ALL EDGES .005/.015
CORNER RADIUS .010/.030
ALL ANGLES ARE 90°

QUADREL LABELING SYSTEMS
7670 JENTHER DRIVE
MENTOR, OHIO 44060
(440) 602-4700

SCALE: 1/2
DATE: 09/08/25
DRW BY: SEM
CHK BY: 09/08/2025-SEM
APPR BY:

REWIND & DANCER ASSEMBLY w/KINETROL, 7"
MAT'L 23100R-007LH

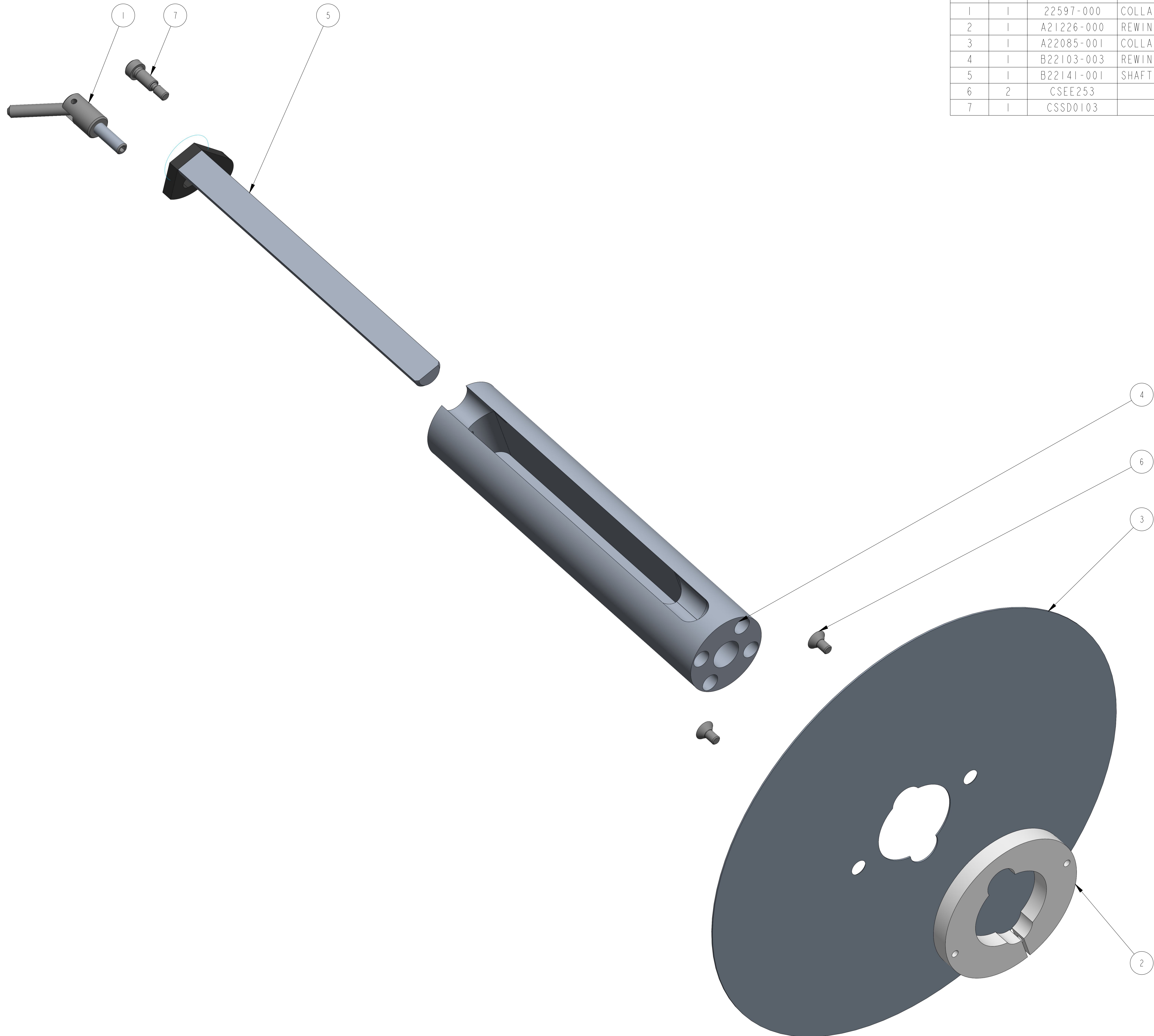

ITEM	QTY	PART NO.	DESCRIPTION	PARENT ITEM
1	1	22597-000	COLLAPSIBLE REWIND LOCKING HANDLE	22188-000
2	1	A21226-000	REWIND FLANGE HUB COLLAR	22188-000
3	1	A22085-001	COLLAPSIBLE REWIND REEL	22188-000
4	1	B22103-003	REWIND HUB 7"	22188-000
5	1	B22141-001	SHAFT ASSEMBLY	22188-000
6	2	CSEE253		22188-000
7	1	CSSD0103		22188-000



REV	DATE	DESCRIPTION	BY
A	MAR-30-21	NEW DRAWING	TJS

THIS IS A PRO-ENGINEER DOCUMENT AND MAY NOT BE MODIFIED MANUALLY

UNLESS OTHERWISE SPECIFIED DIMENSIONAL TOLERANCE	x ± .1 xx ± .01 xxx ± .005 ANGLES ± .30°	SCALE: 1/1 DATE: MAR-30-21 DRW BY: TJS CHK BY: 02/29/2024-SEM APPR BY:
---	---	--

QUADREL LABELING SYSTEMS
 7670 JENTHER DRIVE
 MENTOR, OHIO 44060
 (440) 602-4700

7" COLLAPSIBLE REWIND ASSEMBLY

MAT'L	22188-000	22188-000
-------	-----------	-----------

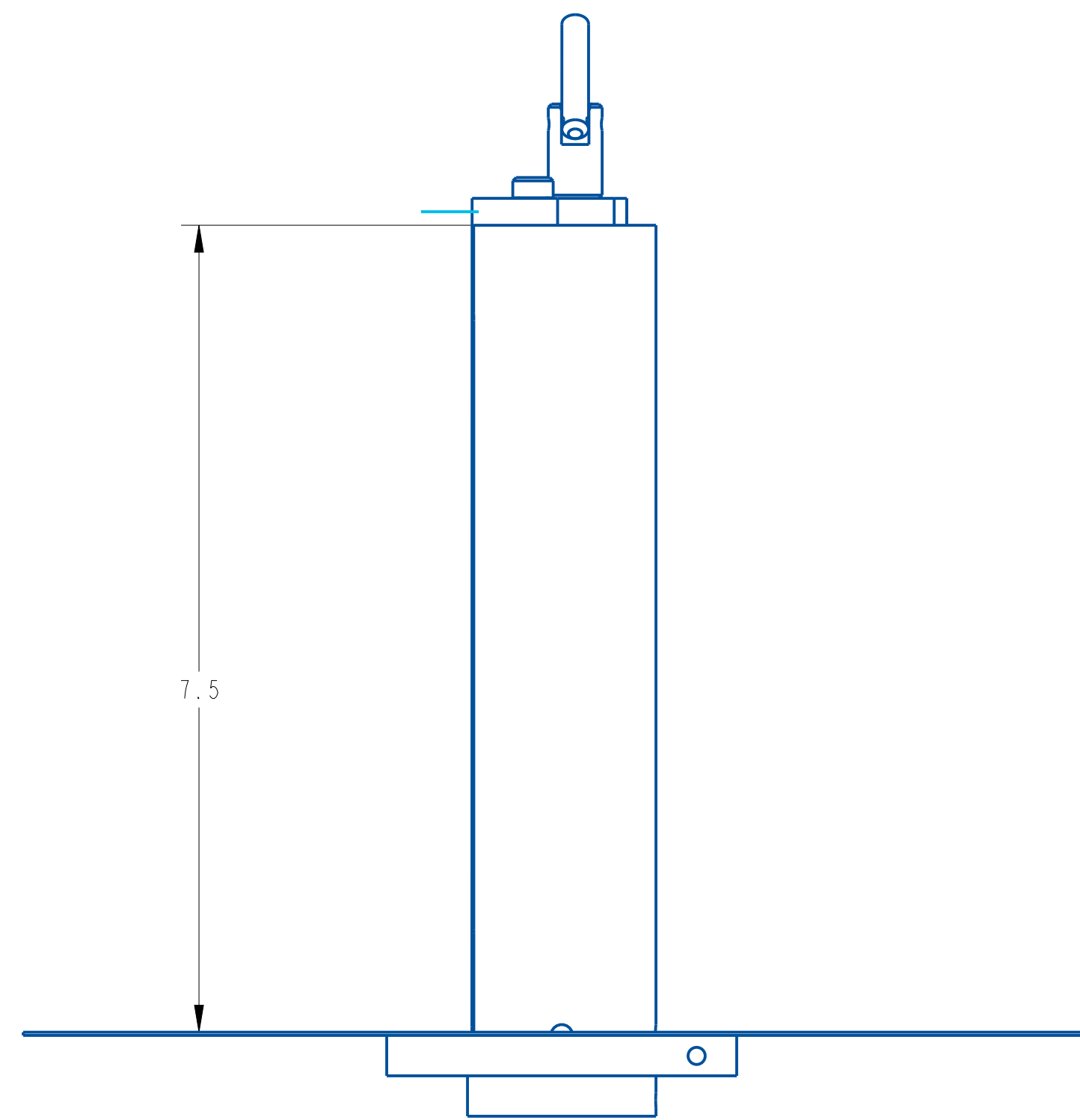
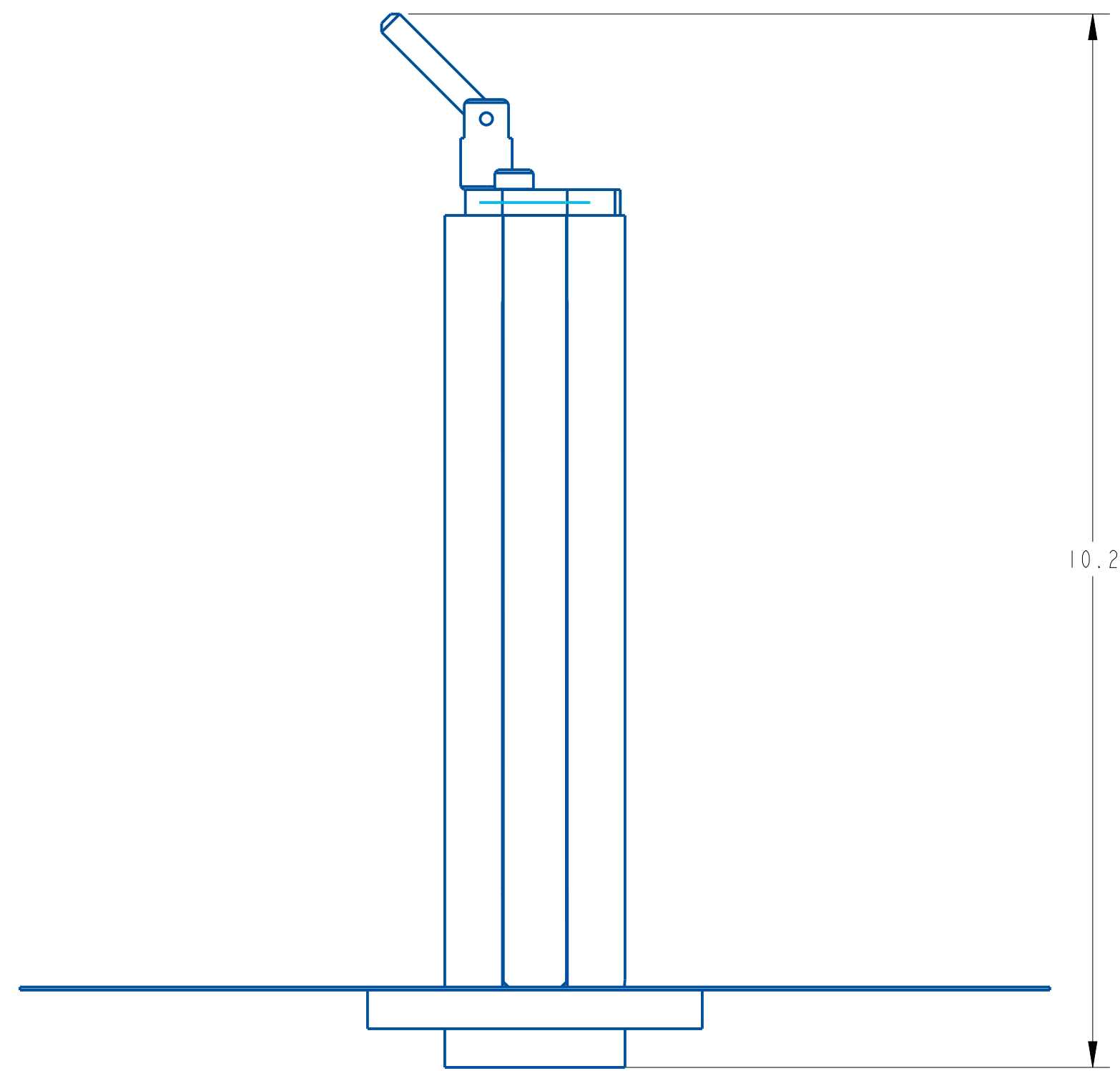
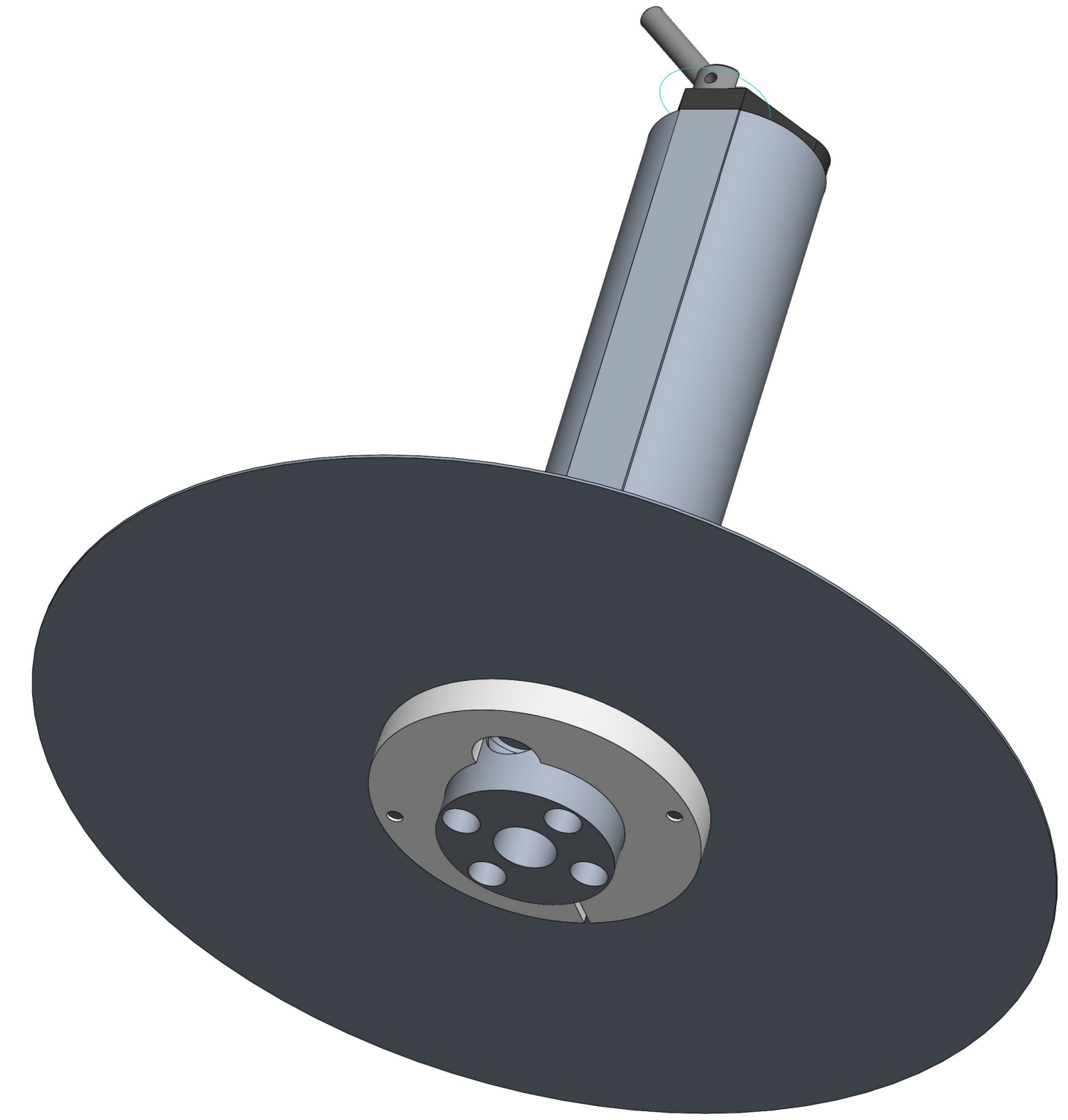
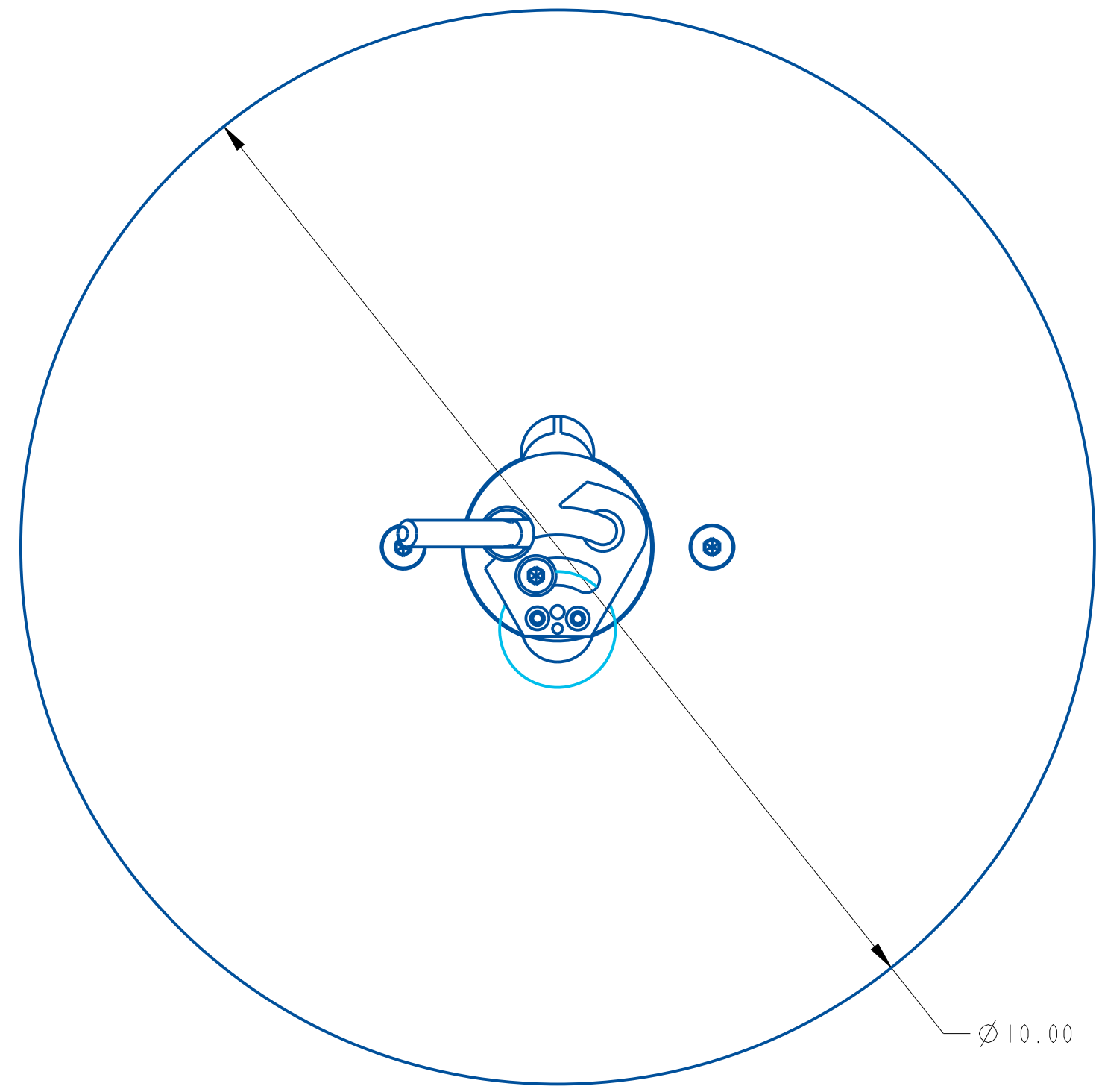

A	MAR-30-21	NEW DRAWING	TJS
REV	DATE	DESCRIPTION	BYE

THIS IS A PRO-ENGINEER DOCUMENT AND MAY NOT BE MODIFIED MANUALLY

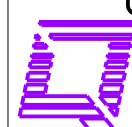
<small>UNLESS OTHERWISE SPECIFIED DIMENSIONAL TOLERANCE</small> X ± .1 XX ± .01 XXX ± .005 ANGLES ± .30° SURFACE FINISH 125 BREAK ALL EDGES .005/ .015 CORNER RADIUS .010/ .030 ALL ANGLES ARE 90°	 QUADREL LABELING SYSTEMS 7670 JENTHER DRIVE MENTOR, OHIO 44060 (440) 602-4700	SCALE: 3/4
		DATE: MAR-30-21
		DRW BY: TJS
		CHK BY: 02/29/2024-SEM
7" COLLAPSIBLE REWIND ASSEMBLY		APPR BY:
MAT'L	22188-000	22188-000

ITEM	QTY	PART NO.	DESCRIPTION
1	1	871352-000	DOWELL,PIN 1/8" x 1/2" SS.
2	1	A26128-000	CLEVIS
3	1	A26129-000	HANDLE
4	1	SYE601	1/4-20 X 1-1/4 LG. SET SCREW

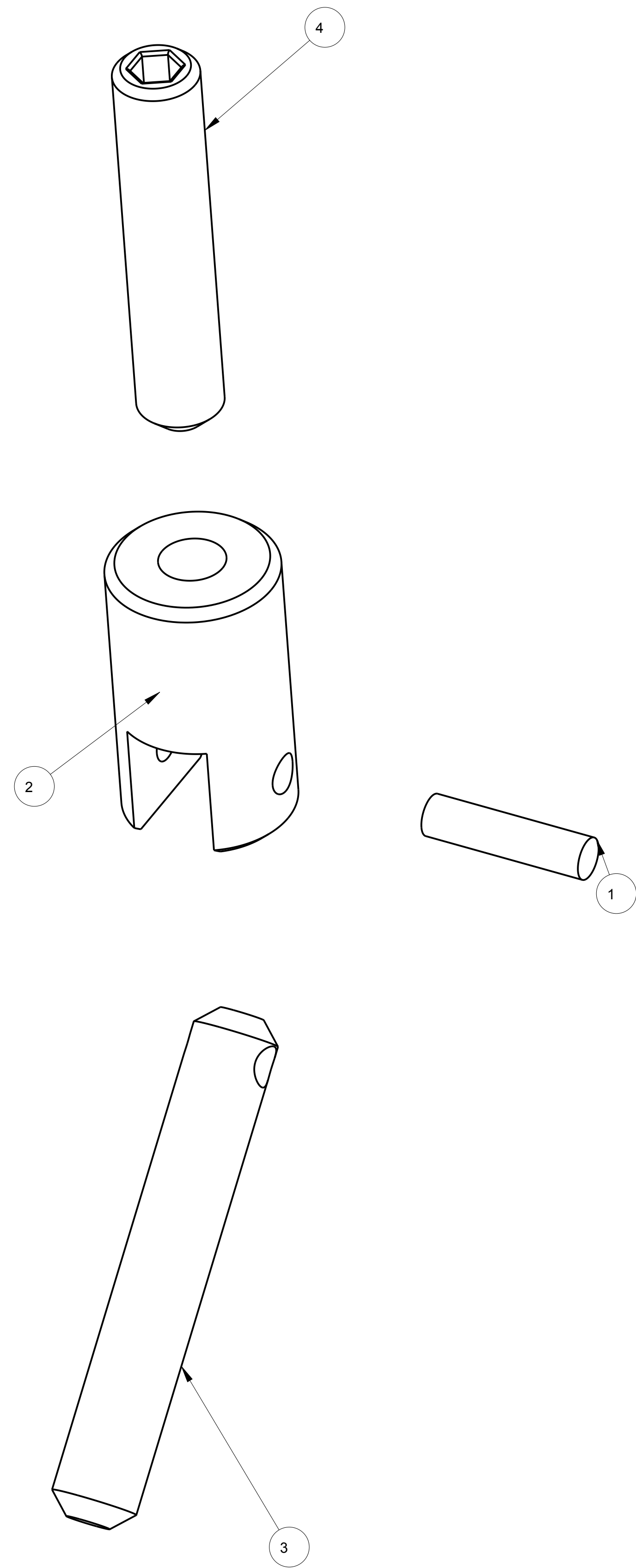

REV	DATE	DESCRIPTION	BY
A	12-11-14	NEW DRAWING	

THIS IS A PRO-ENGINEER DOCUMENT AND MAY NOT BE MODIFIED MANUALLY

UNLESS OTHERWISE SPECIFIED DIMENSIONAL TOLERANCE .X± .1 .XX± .01 .XXX± .005 ANGLES ± 30°	QUADREL LABELING SYSTEMS 7670 JENTHER DRIVE MENTOR, OHIO 44060 (440) 602-4700		SCALE 4/1 DATE 12-11-14 DRAWN BY ATT
	COLLAPSIBLE REWIND LOCKING HANDLE		
	SURFACE FINISH 125 BREAK ALL EDGES .005/.015 CORNER RADIUS .010/.030	MAT'L 22597-000	22597-000

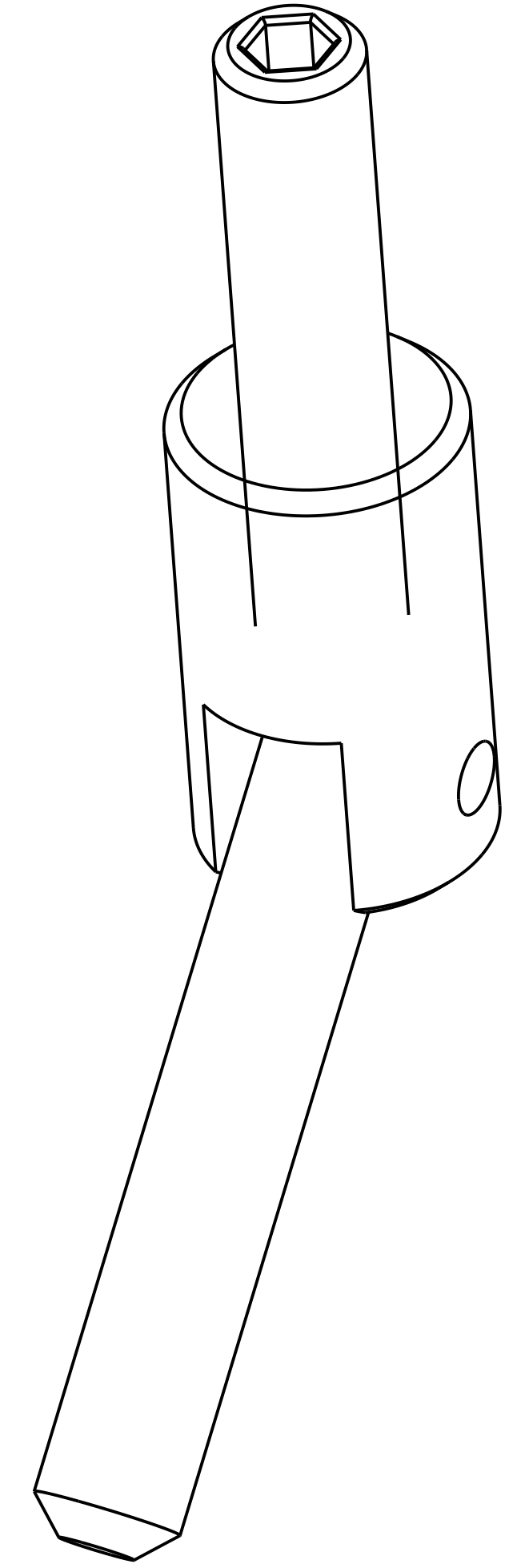
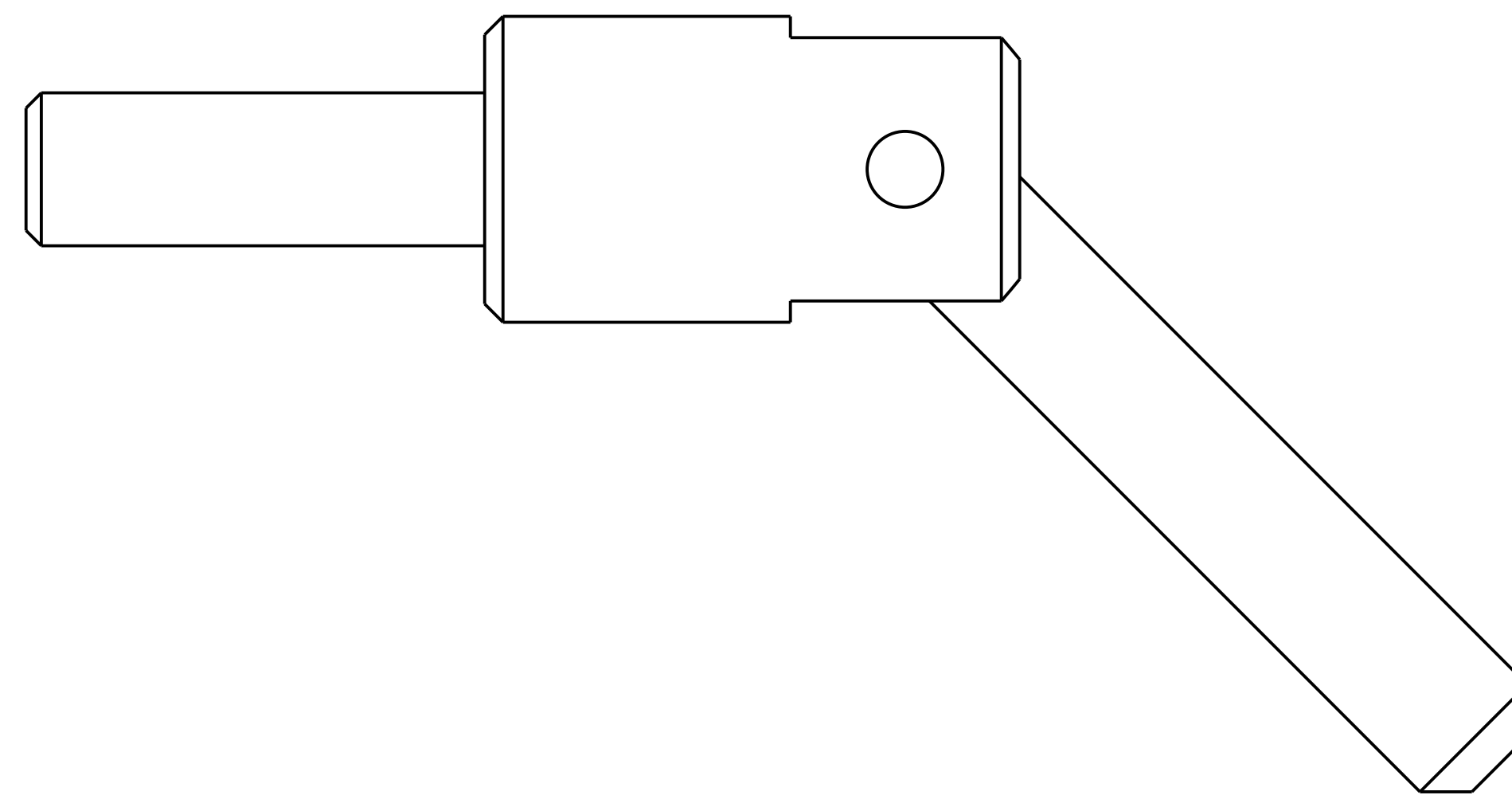
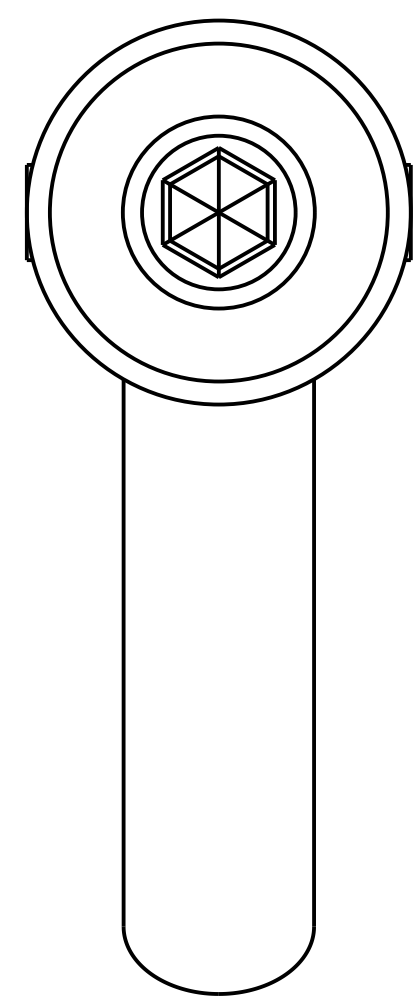
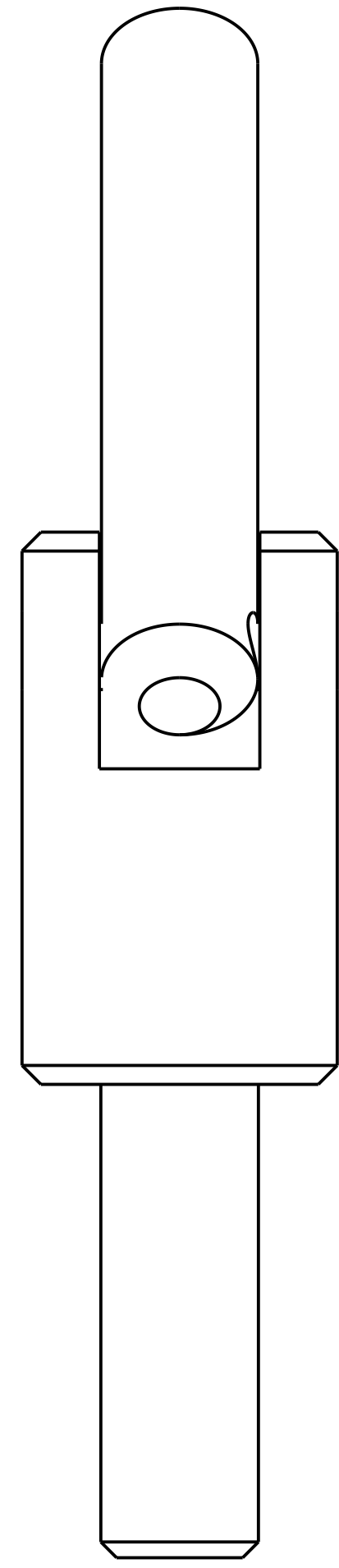

UNLESS OTHERWISE SPECIFIED DIMENSIONAL TOLERANCE		X± .1 XX± .01 XXX± .005 ANGLES ± .30°	
SURFACE FINISH 125 BREAK ALL EDGES .005/015 CORNER RADIUS .010/030		MAT'L 22597-000	

THIS IS A PRO-ENGINEER DOCUMENT AND MAY NOT BE MODIFIED MANUALLY			
REV	DATE	DESCRIPTION	BY
A	12-11-14	NEW DRAWING	
SCALE		4/1	
DATE		12-11-14	
DRAWN BY		ATT	
QUADREL LABELING SYSTEMS 7670 JENTHER DRIVE MENTOR, OHIO 44060 (440) 602-4700			
COLLAPSIBLE REWIND LOCKING HANDLE			
		22597-000	

ASSEMBLY TITLE: Q60 KINETROL REWIND

GENERAL FUNCTION:

- The rewind drum rolls up the liner
- The collapsible rewind shaft when closed allows the liner to be removed easily. The normal running position for the shaft is in the open position
- The rewind flange supports and guides the liner
- The Kinetrol clutch allows for slippage to accommodate for varying speeds between the drive roll and rewind drum
- The adjusting knob controls the torque adjustment of the drum and is set at the factory.

SET UP AND ADJUSTMENTS:

- Position the rewind flange slightly below the web path and lock with the set screw in the hub
- When threading liner to the rewind, place the liner between the drum and pin
- Tighten adjusting knob just enough to allow the rewind drum to keep up with the drive roll.
- Loosen set screw before adjustment and re-tighten after adjustment

NOTE: Excessive tightening will cause the web to be wound very tight, causing difficulty in removal and possible step motor stall.

MAINTENANCE:

- Clean all parts that have acquired label or glue residue

TROUBLESHOOTING:

PROBLEM

- Rewind drum not rotating when stepping motor rotates
- Rewind drum not keeping up with drive roll
- Web winding too tight on hub
- Grinding in rewind hub

WHAT TO DO

- Replace timing belt from motor to rewind
- Adjust clutch dial (1 being loosest & 10 being tightest)
- Loosen adjusting knob
- Replace Kinetrol

Set screw location



ASSEMBLY TITLE: SLOT SENSOR ASSEMBLY

GENERAL FUNCTION:

- The slot sensor detects the separation between labels. This signals the electronics to stop the drive motor.
- The two (2) liner support rods prevent the liner from wearing out the slot sensor.
- The knob and thumbscrew lock the sensor firmly on the mounting rods.
- The male connector provides quick connection to the labeling head.

SET UP AND ADJUSTMENTS:

- See attached cut sheet

MAINTENANCE:

- Keep the sensor optical area clean from label and glue residue

TROUBLESHOOTING:

<u>PROBLEM</u>	<u>WHAT TO DO</u>
- No power to the sensor	- Check male connector and tightly secure connection to the head.
- Liner dragging over the slot	- Loosen knob and rotate slot sensor slot sensor surface liner rests on both support rods
- Too much slack through slot sensor	- Adjust brake brush tension
- Slot sensor moving with web	- Tighten all three (3) adjusting knobs

ITEM	QTY	PART NO.	DESCRIPTION	PARENT ITEM
1	1	201444-300	TRITRONICS MODEL LERC	20033-300
2	2	801297-000	THUMB SCREW PLSTC HEAD 8-32x1	20033-300
3	2	801299-000	KNOB WITH STUD	20033-300
4	1	A21391-301	SLOT SENSOR ADAPTER	20033-300
5	4	A21749-300	SLOT SENSOR SUPPORT ROD MTG BLOCK	20033-300
6	2	A21770-300	SUPPORT ROD WITH FLAT	20033-300
7	1	B20852-300	7 IN. WEB SLOT SENSOR MTG. BAR	20033-300
8	1	203035-000	CABLE, M8, 4COND	NOT SHOWN

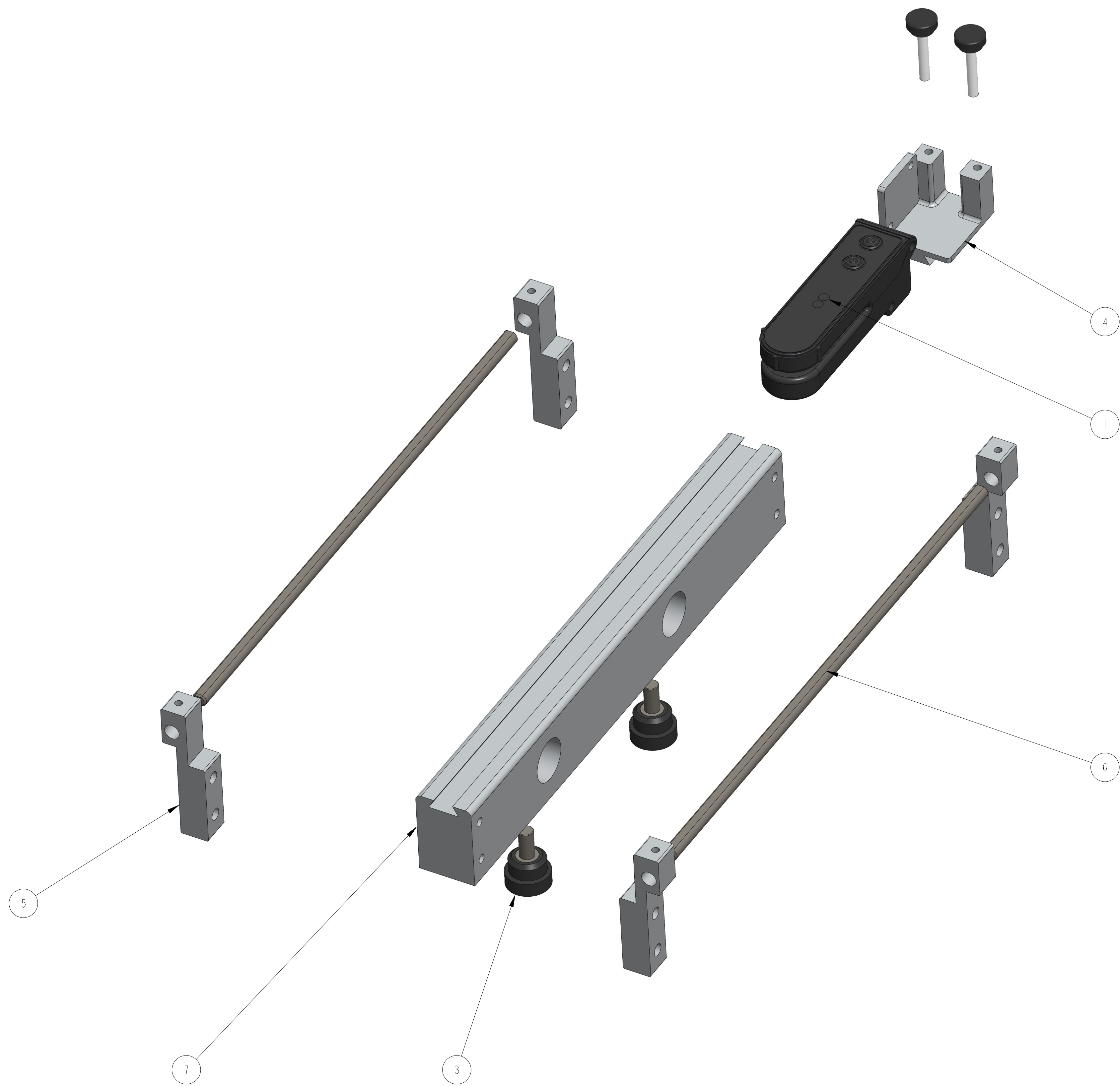

REV	DATE	DESCRIPTION	BY
A	Mar-04-21	NEW DRAWING	TJS

THIS IS A PRO-ENGINEER DOCUMENT AND MAY NOT BE MODIFIED MANUALLY

UNLESS OTHERWISE SPECIFIED DIMENSIONAL TOLERANCE .XX ± .01 .XXX ± .005 ANGLES ± 30° SURFACE FINISH 125 BREAK ALL EDGES .005/0.15 CORNER RADIUS .010/0.30	QUADREL LABELING SYSTEMS 7670 JENTHER DRIVE MENTOR, OHIO 44060 (440) 602-4700	SCALE: 1/1 DATE: Mar-04-21 DRW BY: TJS CHK BY: 02/24/2024-SEM APPR BY:
---	---	--

LABEL DETECT ASSEMBLY

MAT'L 20033-300

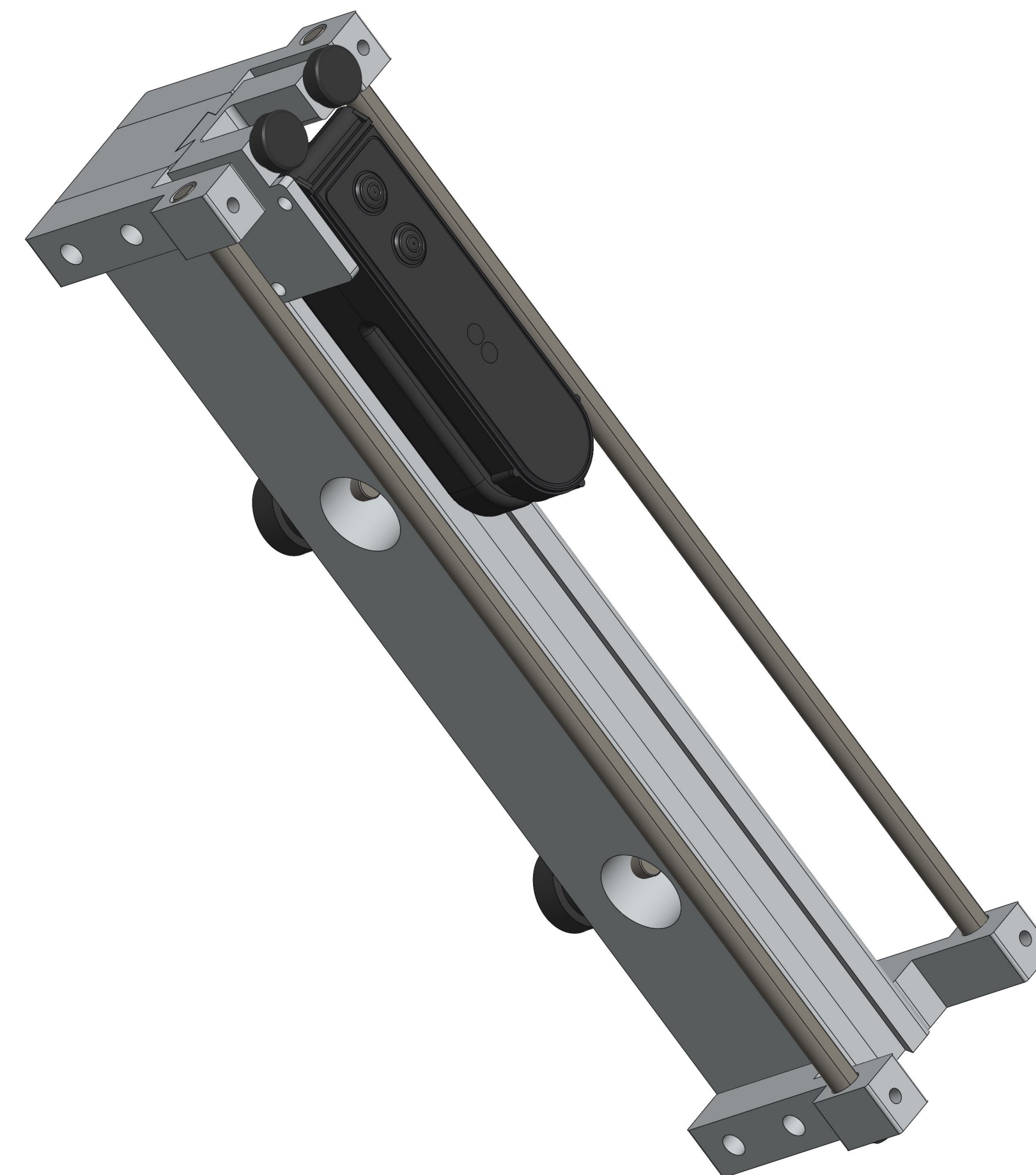
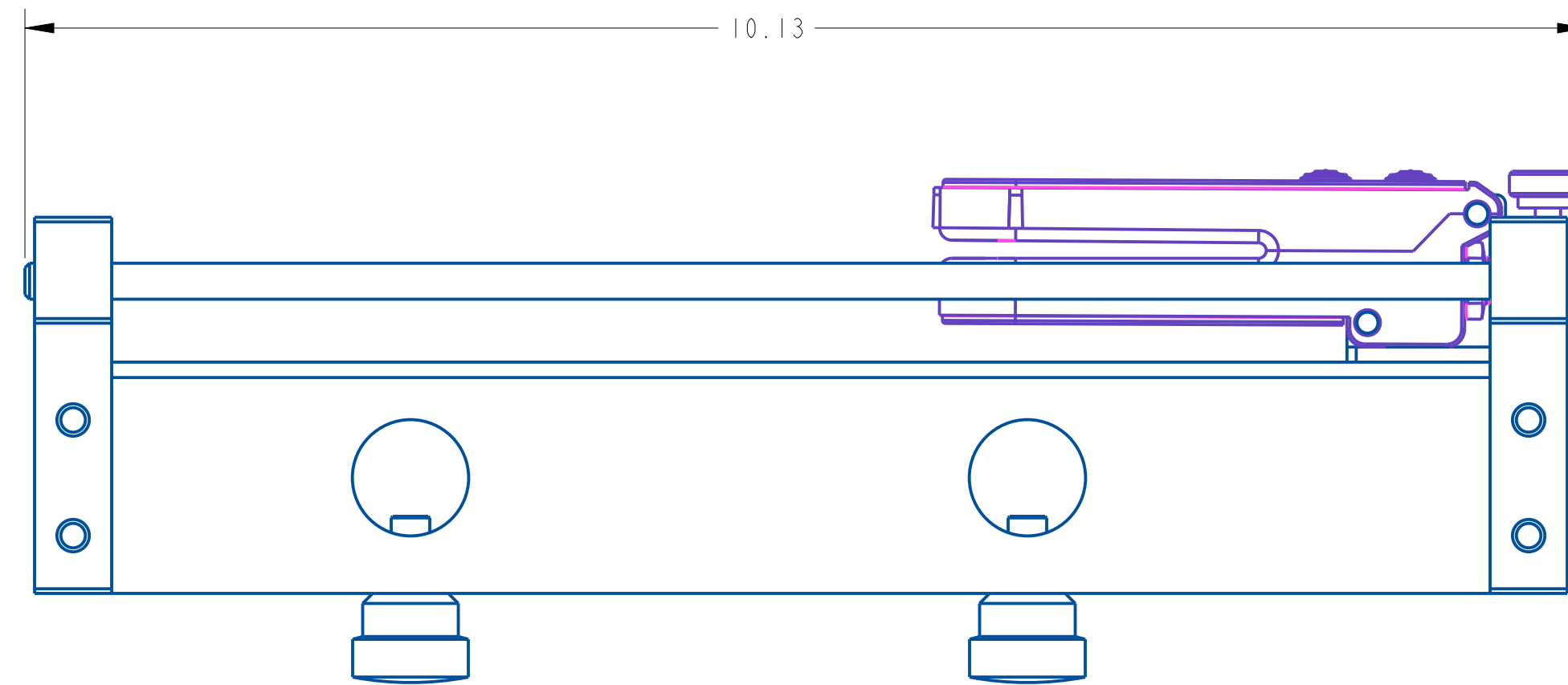
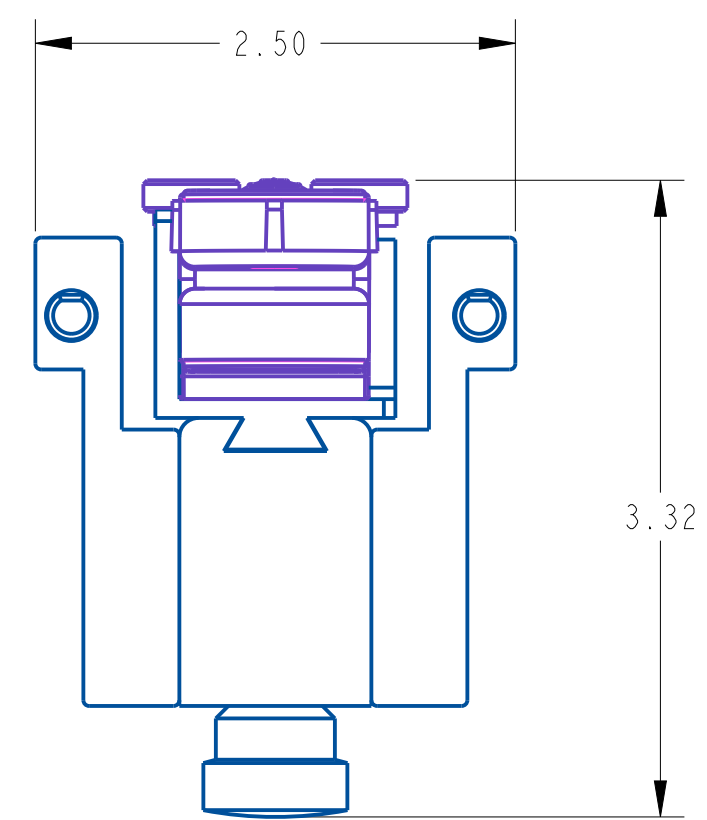
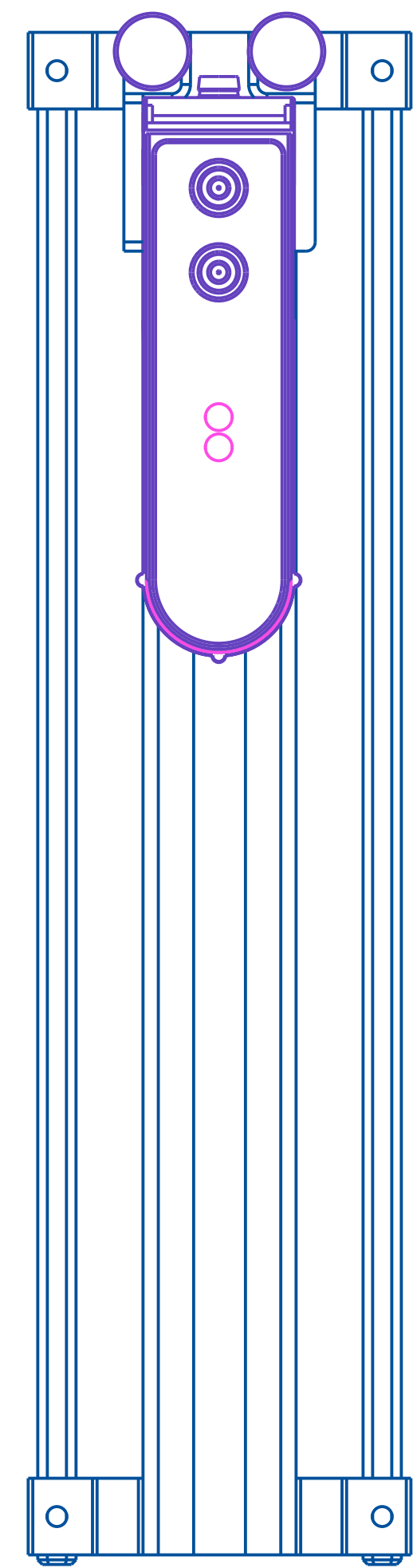

REV	DATE	DESCRIPTION	BY
A	Mar-04-21	NEW DRAWING	TJS

THIS IS A PRO-ENGINEER DOCUMENT AND MAY NOT BE MODIFIED MANUALLY

UNLESS OTHERWISE SPECIFIED
DIMENSIONAL TOLERANCE
X ± .1
XX ± .01
XXX ± .005
ANGLES ± .30°

SURFACE FINISH 125
BREAK ALL EDGES .005/ .015
CORNER RADIUS .010/ .030
ALL ANGLES ARE 90°

QUADREL LABELING SYSTEMS
7670 JENTHER DRIVE
MENTOR, OHIO 44060
(440) 602-4700

SCALE: 1/1
DATE: Mar-04-21
DRW BY: TJS
CHK BY: 02/24/2024-SEM
APPR BY:

LABEL DETECT ASSEMBLY

MAT 'L 20033-300

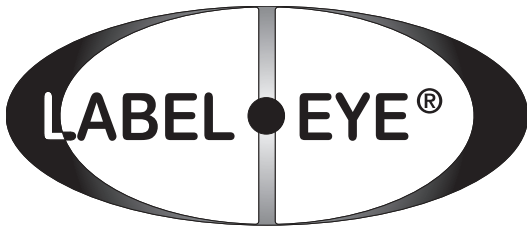

LABEL•EYE Set-Up Instructions

Standard LABEL•EYE

Normal Label Opacity AUTOSET Button

This category includes most paper or metallized film labels adhering to paper or transparent backing materials. To implement the one button AUTOSET routine, utilize the external alignment guides to position the gap between labels in line with the dot shown in the center of the detection zone. Then push the AUTOSET button marked "Normal."

An alternative set up procedure would be to remove a label and the push the "Normal" AUTOSET button.

On rare occasions, when the light is unable to penetrate the backing materials, both the red and green led indicators will blink four times. When this indication occurs, the sensor will be unable to detect the presence of the labels.

Translucent Label Opacity AUTOSET Button

This category includes translucent labels adhering to transparent or paper backing materials. To implement the one button AUTOSET routine, utilize the external alignment guides to position the gap between labels in line with the dot shown in the center of the detection zone. Then push the AUTOSET button marked "Translucent".

Note: This sensor cannot detect transparent labels.

INVERT OUTPUT: The status of the red LED and output transistors can be inverted by pressing both buttons simultaneously. When the output status has been inverted, the red LED and the output transistors will turn off when the label comes into view.

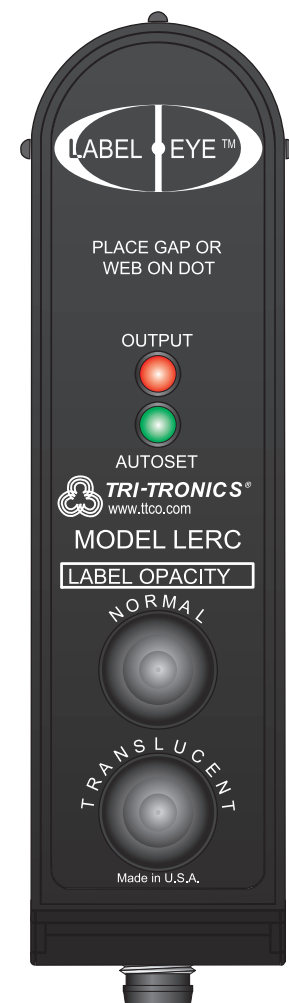

SPECIFICATIONS



SUPPLY VOLTAGE

- 10 to 30Vdc
- Polarity Protected
- Intended for use in class two circuits

CURRENT REQUIREMENTS

- 45 milliamps (exclusive of load)

OUTPUT TRANSISTORS

- (1) NPN and (1) PNP output transistors
- Sensor outputs can sink or source up to 150 milliamps (current limit)
- All outputs are continuously short circuit protected

REMOTE AUTOSET INPUT

- opto isolated momentary sinking input (10 milliamps)
- Note: Remote models only*

RESPONSE TIME

- Light state response = 100 microseconds
- Dark state response = 100 microseconds

LED LIGHT SOURCE

- High intensity red LED
- Pulse modulated

PUSH BUTTON CONTROL

- Automatic set-up routines based on web opacity
- One push button set-up
- Simultaneously pushing both buttons inverts the output

HYSTERESIS

- Minimal hysteresis promotes the detection between the backing material and the label depending on the settings

LIGHT IMMUNITY

- Responds to sensor's pulsed modulated light source ... immune to most ambient light

INDICATORS

- Green LED flashes when AUTOSET routine is activated and stays illuminated when AUTOSET is completed
 - Red LED illuminates when sensors output transistors are ON.
- Note: The status of the output transistors can be inverted by pushing both buttons simultaneously. If Output LED flashes, a short circuit condition exists.*

AMBIENT TEMPERATURE

- -40°C to 70°C (-40°F to 158°F)

RUGGED CONSTRUCTION

- Chemical resistance to harsh cleaners such as detergents, alcohols, and ketones
- Type 1 Enclosure
- Conforms to heavy industry grade CE and UL requirements



RoHS Compliant
Product subject to change without notice.

Model Numbers:

Label•Eye	Description
LER	Red LED, 4 Conductor 6ft Cable
LERC	Red LED, 4-pin M8 Connector
LERR	Red LED, 5 Conductor, 6ft Cable
LERRC-M12	Red LED, 5-Pin M12 Pigtail Connector
LERC-M12	Red LED, 4-Pin M12 Pigtail Connector

Nano Cable (M8) Selection Guide

P/N	Length	Thread Coupling
GEC-6	6ft (1.8m)	Straight Female
GEC-15	15ft (4.6m)	Straight Female
RGEC-6	6ft (1.8m)	90° Female
RGEC-15	15ft (4.6m)	90° Female

DIMENSIONS

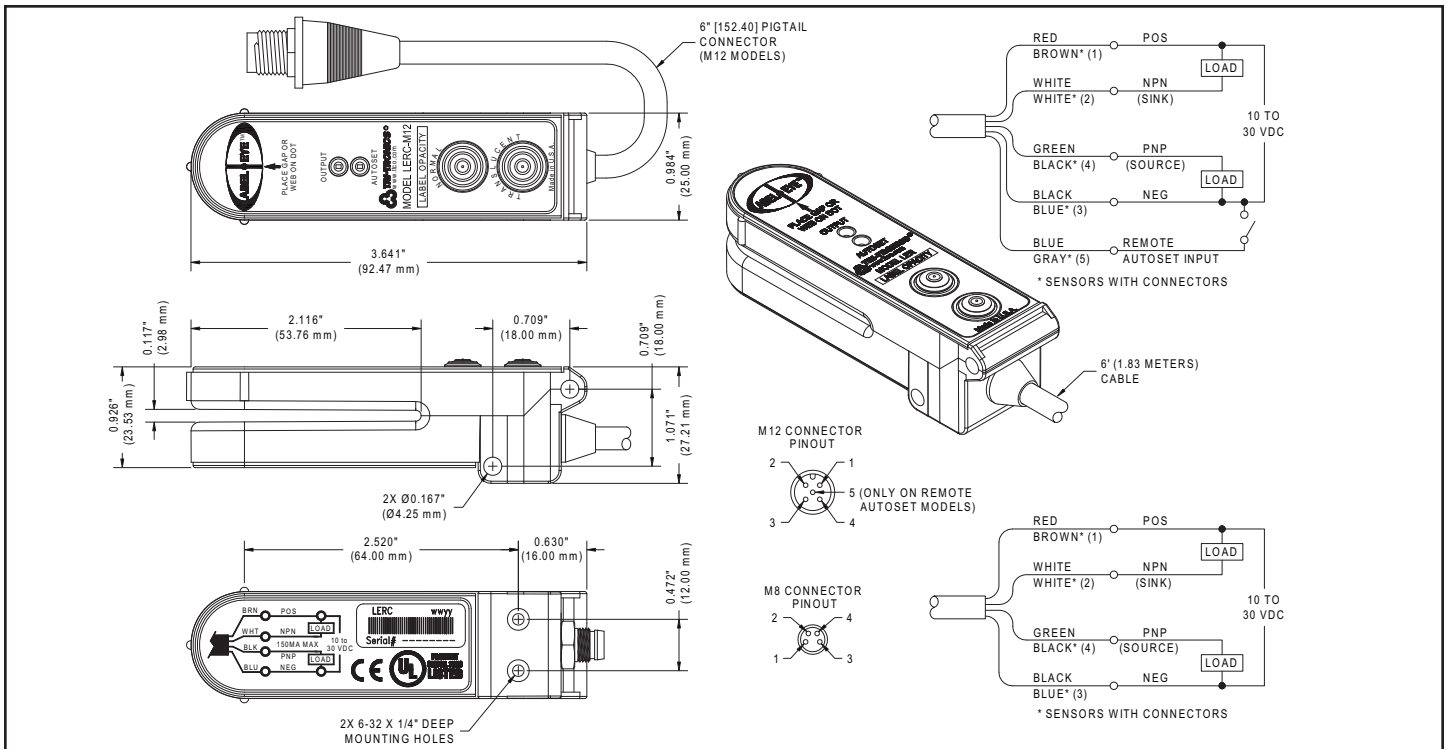

P.O. BOX 25135, TAMPA, FL 33622-5135
813-886-4000 / 800-237-0946
tco.com / info@tco.com

ASSEMBLY TITLE: LOW LABEL FAULT ASSEMBLY

DRAWING NO.:

GENERAL FUNCTION:

- The low label supply fault indicates a depleting supply of labels. It consists of a fiber optic sensor that is set at the desired position on the roll of labels.
- When the label supply passes below the sensor range, a signal is generated this will light the yellow stack lamp and enunciate a low label condition on the operator's touch screen display.
- The male connector provides quick connection to the labeling head.

SET UP AND ADJUSTMENTS:

- Set the sensor eye just before the cardboard inner core, approximately ¼" below the supply reel flange and lined up with the sensing hole in the flange.

MAINTENANCE:

- Keep the sensor optical area clean from label and glue residue

TROUBLESHOOTING:

<u>PROBLEM</u>	<u>WHAT TO DO</u>
- No power to the sensor	- Check male connector and tightly secure connection to the head.

NOTE: The labeler will continue to operate until the operator pauses the labeler or the label supply completely depletes past the broken web sensor.

To reset the fault condition, replenish the label supply and press the labeler run button from run to pause and back to run.

ITEM	QTY	PART NO.	DESCRIPTION	PARENT ITEM
1	1	202201-000	DUAL DIGITAL FIBER AMPLIFIER	20776-006
2	1	202201-001	DUAL DIGITAL FIBER AMPLIFIER	20776-006
3	1	203170-000	CABLE, FIBER , REFLECTIVE, KEYENCE #FU-67V	20776-006
4	1	A23727-000	LOW LEVEL BRACKET	20776-006
5	1	A23728-000	LOW LEVEL SENSOR TUBE	20776-006

*NOT SHOWN
252019-000 CONNECTOR

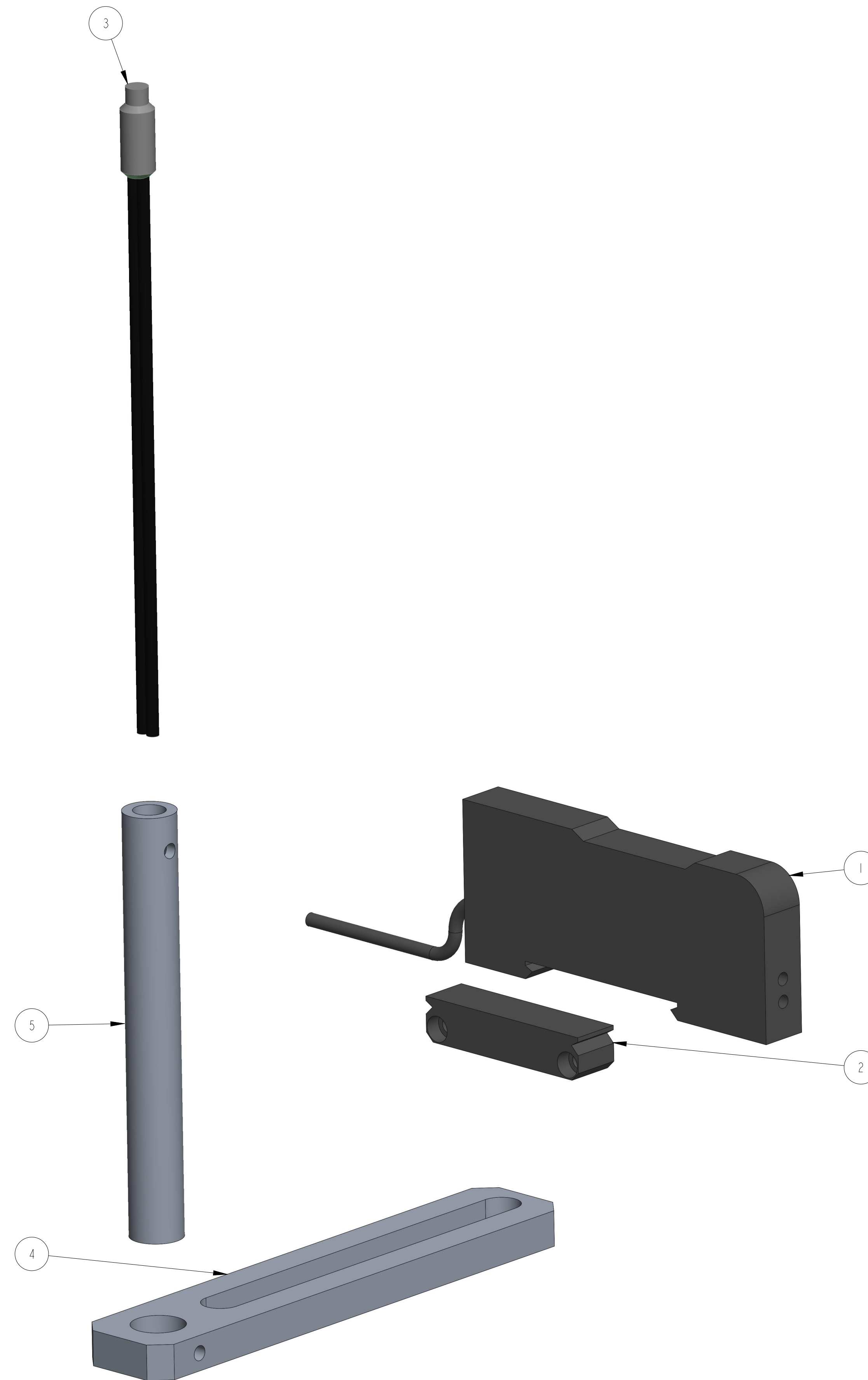

REV	DATE	DESCRIPTION	BY
A	Apr-07-21	NEW DRAWING	TJS

THIS IS A PRO-ENGINEER DOCUMENT AND MAY NOT BE MODIFIED MANUALLY

QUADREL LABELING SYSTEMS
7670 JENTHER DRIVE
MENTOR, OHIO 44060
(440) 602-4700

SCALE: 2/1
DATE: Apr-07-21
DRAWN BY: TJS

MAT'L: 20776-006 & 20776-006P
20776-006

LOW LABEL

UNLESS OTHERWISE SPECIFIED
DIMENSIONAL TOLERANCE
XX ± .01
XXX ± .005
ANGLES ± 30°
SURFACE FINISH 125
BREAK ALL EDGES .005/.015
CORNER RADIUS .010/.030

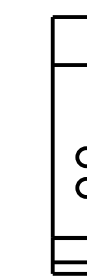
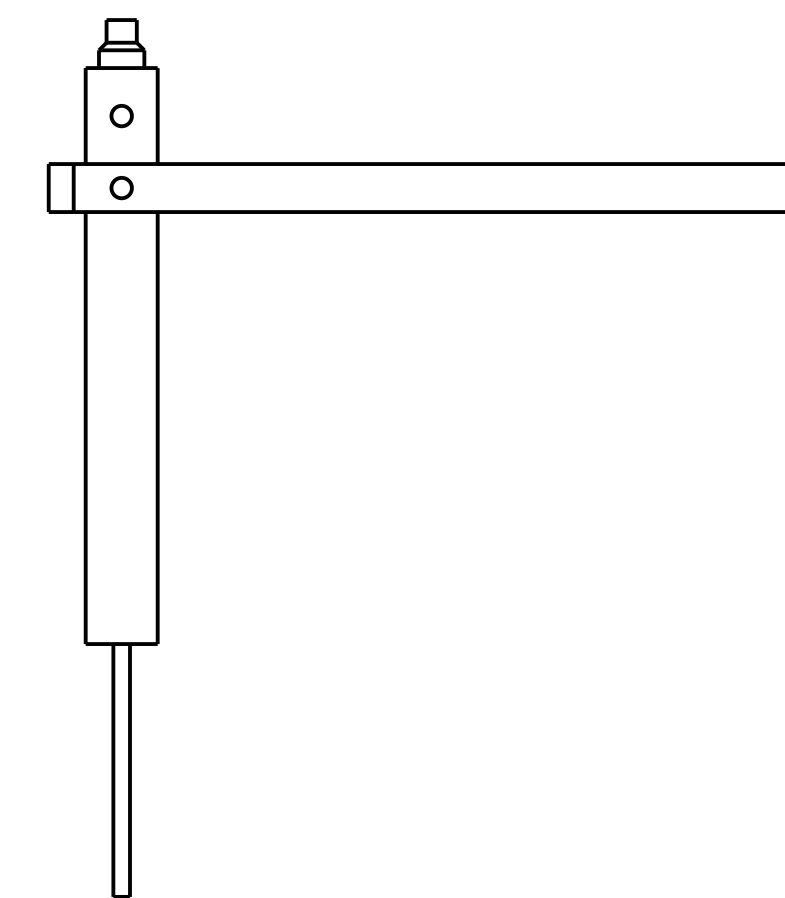
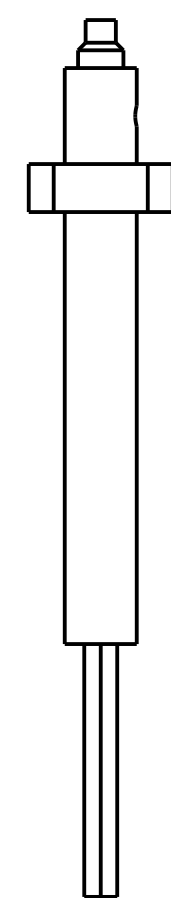
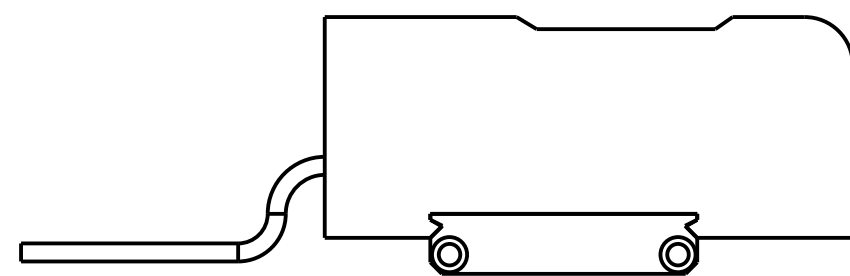
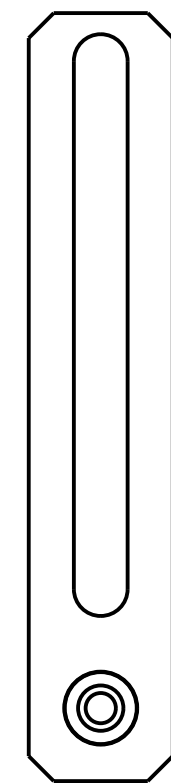
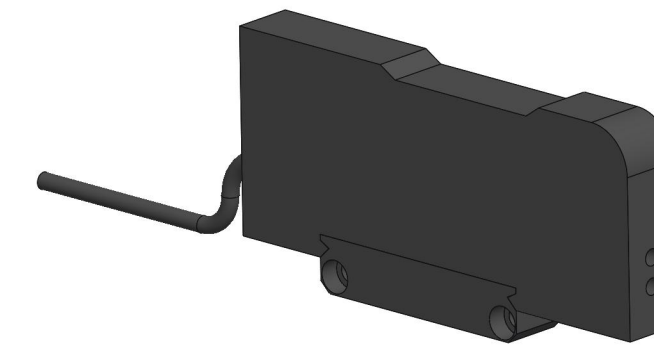

THIS IS A PRO-ENGINEER DOCUMENT AND MAY NOT BE MODIFIED MANUALLY			
UNLESS OTHERWISE SPECIFIED DIMENSIONAL TOLERANCE		QUADREL LABELING SYSTEMS 7670 JENTHER DRIVE MENTOR, OHIO 44060 (440) 602-4700	
X ± .1 .XX ± .01 .XXX ± .005 ANGLES ± 30°	SCALE: 1/1 DATE: Apr-07-21 DRAWN BY: TJS		SURFACE FINISH: 125 BREAK ALL EDGES: .005/.015 CORNER RADIUS: .010/.030
MAT'L 20776-006 & 20776-006P		LOW LABEL 20776-006	



Digital Fiberoptic Sensor FS-N40 Series Instruction Manual

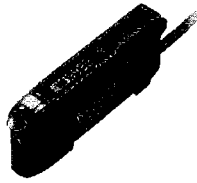

Read this manual before using the product in order to achieve maximum performance. Keep this manual in a safe place after reading it so that it can be used at any time.

For detailed FS-N40 Series setting methods and for details on the functions of the FS-N40 Series, see the "FS-N40 Series User's Manual".

■ Symbols

The following symbols are used in this instruction manual to enable the recognition of important information at a glance. Be sure to read these messages carefully.

	It indicates a hazardous situation which, if not avoided, will result in death or serious injury.
	It indicates a hazardous situation which, if not avoided, could result in death or serious injury.
	It indicates a hazardous situation which, if not avoided, could result in minor or moderate injury.
	It indicates a situation which, if not avoided, could result in product damage as well as property damage.

1 Before Operation

Safety Precautions

	<ul style="list-style-type: none"> This product is only intended to detect objects. Do not use this product for the purpose of protecting a human body or a part of a human body. This product is not intended for use as an explosion-proof product. Do not use this product in a hazardous location and/or potentially explosive atmosphere.
	<ul style="list-style-type: none"> This is a direct current (DC) power supply type sensor. Application of an alternating current may result in explosion or fire.
	<ul style="list-style-type: none"> Use separate conduits for power lines and high-voltage lines. Use of a common conduit may result in device malfunction due to noise or damage to the sensor. Always ground the frame ground terminal when using an off-the-shelf switching regulator. Do not use this product outdoors.

Precautions on Regulations and Standards

■ CE Marking

KEYENCE Corporation has confirmed, on the basis of the following specifications, that this product complies with the essential requirements of the applicable EU Directive(s). Be sure to consider the following specifications when using this product in the member states of the European Union.

● EMC Directive, applicable standard: EN60947-5-2, Class A

Ensure that the cable length is 30 meters or less. These specifications do not give any guarantee that the end-product with this product incorporated complies with the essential requirements of the EMC Directive. The manufacturer of the end-product is solely responsible for confirming the compliance of the end-product itself according to the EMC Directive.

■ UL Certificate

This product is a UL/c-UL certified product.

- UL File No.: E301717
- Category: NRKH/NRKH7(NRKH2/NRKH8: FS-N42N(P))
- Enclosure Type 1 (based on UL50)

Be sure to consider the following specifications when using this product as a UL/c-UL certified product.

- Use a power supply with Class 2 output defined in NFPA70 (NEC: National Electrical Code).
- Connect the power supply, external input, and control output to a single power supply with Class 2 output.
- Use OP-73864, OP-73865 or OP-85498 cable with FS-N41C when the field wiring is required.

■ FCC Regulations

This product complies with the following regulations specified by the FCC.

- Applicable regulation FCC Part 15 Subpart B Class A
- This device complies with part 15 of the FCC Rules. Operation is subject to the following two conditions: (1) This device may not cause harmful interference, and (2) this device must accept any interference received, including interference that may cause undesired operation.

• FCC Caution

Changes or modifications not expressly approved by the party responsible for compliance could void the user's authority to operate the equipment.

Package Contents

- Main unit
- Instruction manual

2 Installation and Wiring

Mounting the Main Unit

■ Mounting the Main Unit on a DIN rail

- 1 Align the claw at the bottom of the main unit with the DIN rail, as shown in the figure. While pushing the main body in the direction of arrow 1, push down in the direction of arrow 2.
- 2 To remove the sensor, raise the main body in the direction of arrow 3 while pushing the main body in the direction of arrow 1.

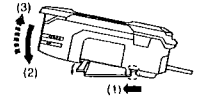

■ Installation on a wall (main unit only)

- 1 Attach the main unit to the optional mounting adapter (OP-88245), and then insert M3 screws into the two locations shown in the figure to secure the main unit in place.

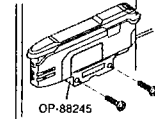

Connecting Multiple Amplifiers

Up to 16 expansion units can be connected to 1 main unit. However, each dual output type will be treated as 2 expansion units.

	When connecting to multiple amplifiers or when mounting main units together, mount the units on a DIN rail installed on a metal surface.
	<ul style="list-style-type: none"> • Be sure to turn the power off before connecting multiple expansion units. • Do not touch the expansion connector.

- 1 Remove the protection covers from the main unit and expansion unit(s).

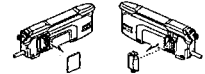

- 2 Install the amplifiers on the DIN rail one at a time.

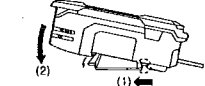

- 3 Slide the main unit and expansion unit(s) together. Mate the two claws of the expansion unit with the recesses on the main unit side until a click is heard/felt.

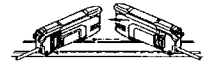

- 4 Attach the end units (optional, sold separately: OP-26751) to the DIN rail on both sides of the amplifiers in the same way as step (2).

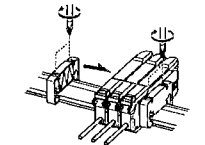

- 5 Secure the amplifiers between the end units. Tighten the screws from the top (two screws x two units) with a Phillips screwdriver to fix the end units in place.

OP-26751 (a set of two)

Fiber Unit Installation

■ Using a fiber cutter

- 1 Insert the fiber into the cutter hole.
- 2 Bring down the blade in a single, swift motion to cut the fiber. (Do not use a hole that has already been used.)

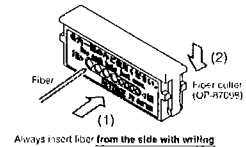

Always insert fiber from the side with writing

■ Connecting to the amplifier unit

- 1 Open the cover (1), and then lower the lever in the direction indicated by (2).
- 2 Insert the fiber unit into the installation holes (approximately 14 mm). (3)
- 3 Move the lever back in the direction indicated by (4).

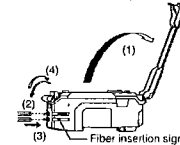

	When installing a coaxial reflective fiber in the main unit, install the single-core fiber in the transmission installation hole and the multi-core fiber in the reception installation hole.
--	---

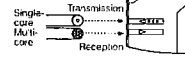

Wiring (Cable Type)

● FS-N41N/N42N/N43N/N44N

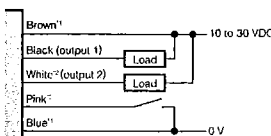

- *1 FS-N41N/N43N only
- *2 FS-N43N/N44N only

● FS-N41P/N42P/N43P/N44P

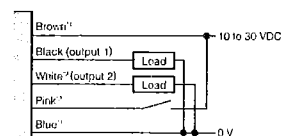

- *1 FS-N41P/N43P only
- *2 FS-N43P/N44P only

Wiring (M8 Connector Type: FS-N41C)

Select NPN or PNP and the function of I/O pin (2) during the initial settings.

Sensor pin layout



FS-N41C supports "IO-Link: Specification V.1.1/COM2 (38.4 kbps)". The setting file (IODD) can be downloaded from Keyence's web site (<http://www.keyence.com>).

● When using the sensor in PNP mode

OUT1 + OUT2

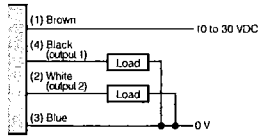

OUT1 + INPUT

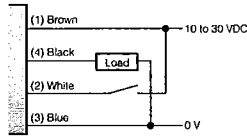

● When using the sensor in NPN mode

OUT1 + OUT2

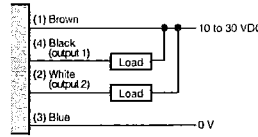

OUT1 + INPUT

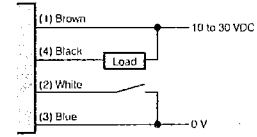

The wire colors indicate the colors when using an OP-73864/73865 M8 connector cable (sold separately).

3 Basic Settings

■ Names and functions

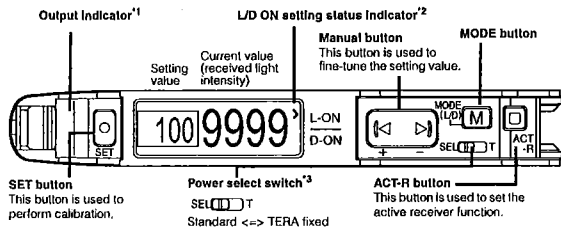

- *1 On dual output types (including the FS-N41C), the indicator operates according to the output channel selected with the output channel selection switch.
- *2 On dual output types (including the FS-N41C), this becomes the output indicator. It displays the current output status of channels 1 and 2.
- *3 On dual output types (including the FS-N41C), this becomes the output channel selection switch. It is not present on zero line types (FS-N40).

■ Initial settings (FS-N41C only)

When turning on the sensor for the first time, or when the sensor has been initialized, select the initial settings shown below.

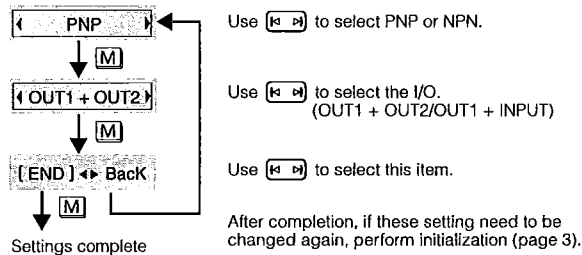

■ Basic settings

● Switching the output style (Light ON/Dark ON)

- 1 Press **[M]** once. Switch L-On/D-On
- 2 Use **[K D]** to switch the output style.
- 3 Press **[M]** three times.

● Switching the display language

- 1 Press **[M]** twice. Language / 语言
- 2 Use **[K D]** to select the language.
- 3 Press **[M]** twice.

● Fine-tuning the setting value (threshold)

Use **[K D]** to adjust the value. Hold down the button to make adjustments more quickly.

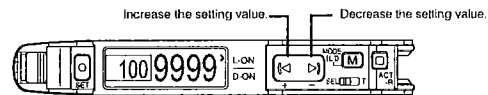

■ Basic calibration methods

● 2-point calibration (the most basic setting method)

- 1 Press **[SET]** with no object to detect present.

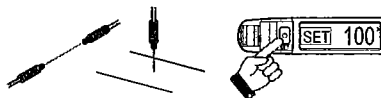

- 2 Press **[SET]** with an object to detect present.

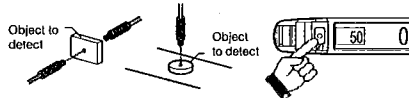

This sets the setting value to the midpoint between the received light intensities of points 1 and 2. If "..." blinks for 2 seconds on the display, the difference between the received light intensities is small, and detection may be unstable.

● Maximum sensitivity calibration

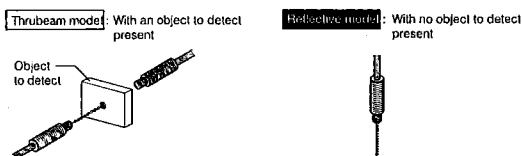

- 1 With the items arranged as shown in the figures on the left, hold down **[SET]** for 3 seconds or more. When **[SET]** blinks, release this button.

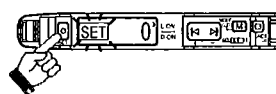

The setting value is set slightly higher than the received light intensity when the setting was configured.

4 Useful Functions

● Initialization

Initialize all the settings and return the sensor to its factory default state.

- 1 Hold down and for 3 seconds or more.
- 2 Press once.
- 3 Press once.
- 4 Press once.

● Key lock

Disable button operations.

- 1 Hold down and for 3 seconds or more.

Cancel: Use the same procedure.

● Active receiver (ACT-R)

This function makes the fiber unit's receiver blink in green.

Operation when the sensor is shipped from the factory

When the sensor output is ON, the fiber unit's receiver lights in green. (This is linked to the output.)

To change the normal lighting status of the receiver (change the settings)

- 1 Press three times.
- 2 Use to select the status from those shown below.

Output Link: The receiver will light when the output is ON.
Reversed Op: The receiver will light when the output is OFF.
Always On: The receiver will be lit always.
Disable: The receiver will be off always.

- 3 Press twice to return to the normal status.

To force the receiver to blink in green (pairing mode)

- 1 Press once.
- 2 Press .
- 3 The light-receiving side blinks in green.
- 4 Press four times to return to the normal status.

● Saturation avoidance function

Use this function when the received light intensity does not change from the maximum displayed value.

- 1 Press and simultaneously.

Cancel: Use the same procedure.



● Zero shift function

Use this function to change the received light intensity display to zero.

- 1 Press and simultaneously.

Cancel: Hold down and for 3 seconds or more.

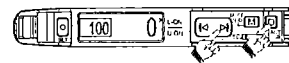

To make it easy to perform optical-axis alignment (optical-axis alignment assist mode)

- 1 Press twice.
- 2 Press to make the light-receiving side blink in green.
- 3 Move the tip of the fiber unit within the movable range.

The light-receiving side lights in green near the peak light intensity within the range in which the tip moved.

Align the optical axis within the middle of the range in which the light-receiving side lights.

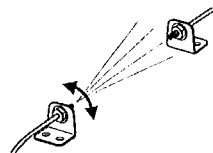

- 4 When you finish the alignment, press three times.

The sensor returns to the normal status.

5 Specifications

The response times are listed on the following page.

Model	NPN output		FS-N41N	FS-N42N	FS-N43N	FS-N44N	FS-N41C ¹		FS-N40
	PNP output		FS-N41P	FS-N42P	FS-N43P	FS-N44P	(selectable output)		
Cable/connecter	Cable						MS connector ²		-
Main unit/expansion unit	Main unit		Expansion unit		Main unit		Expansion unit		Expansion unit
Number of control outputs	1		1		2		2 ³		None ⁴
Number of external inputs	-		-		1		1		1 ³
Light source LED	Transmitter side: Red, four-element LED (wavelength: 660 nm)								
Control output	Open-collector, 30 V or less 100 mA or less per output, 100 mA or less total for 2 outputs (when used as a solitary unit) 20 mA (when used as an expansion unit)								
	Residual voltage	NPN 1.4 V or less (output current: 10 mA or less) 2 V or less (output current: 10 to 100 mA) PNP 1.6 V or less (output current: 10 mA or less) 2.2 V or less (output current: 10 to 100 mA)							
External input	Input time: 2 ms (ON)/20 ms (OFF) or longer ⁵								
Unit expansion (excluding the FS-N41C)	Up to 16 units (17 units connected in total including the main unit). However, each two output type will be treated as two expansion units.								
Protection circuit	Protection against reverse power connection, output overcurrent, output surge, and reverse output connection								
Mutual interference prevention	S-HSPD/HSPD: 0 units, FINE: 4 units, TURBO/SUPER/ULTRA/MEGA/TERA: 8 units (The mutual interference prevention values are twice those shown here when Double Is set.)								
Power supply	Power supply voltage								
	10 to 30 VDC (including 10% ripple (P-P) or less), class 2 or LPS ⁶								
Power consumption ⁷	NPN FS-N40								
	During normal operation: 870 mW or less (34 mA or less at 24 V/62 mA or less at 12 V) ECO ON: 800 mW or less (31 mA or less at 24 V/56 mA or less at 12 V) ECO FULL: 710 mW or less (28 mA or less at 24 V/49 mA or less at 12 V)								
Power consumption ⁷	PNP FS-N41C								
	One output type (FS-N41P/N42P) and FS-N41C During normal operation: 910 mW or less (36 mA or less at 24 V/65 mA or less at 12 V) ECO ON: 840 mW or less (33 mA or less at 24 V/60 mA or less at 12 V) ECO FULL: 750 mW or less (30 mA or less at 24 V/52 mA or less at 12 V)								
Power consumption ⁷	Two output type (FS-N43P/N44P)								
	During normal operation: 990 mW or less (39 mA or less at 24 V/72 mA or less at 12 V) ECO ON: 920 mW or less (36 mA or less at 24 V/66 mA or less at 12 V) ECO FULL: 830 mW or less (33 mA or less at 24 V/59 mA or less at 12 V)								
Ambient light	Incandescent lamp: 20,000 lx or less, sunlight: 30,000 lx or less								
Ambient temperature	-20°C to +55°C (no freezing) ⁸								
Vibration resistance	10 to 55 Hz; double amplitude 1.5 mm, 2 hours each for X, Y, and Z axes								
Shock resistance	500 m/s ² ; 3 times each for X, Y, and Z axes								
Case material	Main unit and cover: polycarbonate								
Weight	Approx. 79 g	Approx. 48 g	Approx. 83 g	Approx. 73 g	Approx. 25 g	Approx. 23 g			

¹ IO-Link Specification V1, MCOM2 (38.4 kbps) is supported.
² Ensure the cable length is 30 m or less for the MS connector type. In case of connecting with IO-Link, set it to 20 m or less.
³ Output 2 and the external input are selectable.
⁴ This counts as 1 output when connecting multiple units to the FS-MCBNPN, NLP Series.
⁵ The input time becomes 25 ms (ON)/25 ms (OFF) when external calibration input is selected.

⁶ When expanding the system to 9 or more units, use a power supply voltage of 12 V or higher.
⁷ The load current is excluded. The power consumption including the load when the maximum number of units are connected is 38 W max.
⁸ When expanded by 1 to 2 units: -20°C to +55°C. When expanded by 3 to 10 units: -20°C to +50°C. When expanded by 11 to 16 units: -20°C to +45°C. When using 2 outputs, 1 unit is counted as 2 units. Note that all the temperature prescriptions assume that the sensor has been mounted on a DIN rail installed on a metal surface. Exercise special care when installing the product in an airtight space.

WARRANTIES AND DISCLAIMERS

- (1) KEYENCE warrants the Products to be free of defects in materials and workmanship for a period of one (1) year from the date of shipment. If any models or samples were shown to Buyer, such models or samples were used merely to illustrate the general type and quality of the Products and not to represent that the Products would necessarily conform to said models or samples. Any Products found to be defective must be shipped to KEYENCE with all shipping costs paid by Buyer or offered to KEYENCE for inspection and examination. Upon examination by KEYENCE, KEYENCE, at its sole option, will refund the purchase price of, or repair or replace at no charge any Products found to be defective. This warranty does not apply to any defects resulting from any action of Buyer, including but not limited to improper installation, improper interfacing, improper repair, unauthorized modification, misapplication and mishandling, such as exposure to excessive current, heat, condensation, moisture, vibration or outdoors air. Components which wear are not warranted.
- (2) KEYENCE is pleased to offer suggestions on the use of its various Products. They are only suggestions, and it is Buyer's responsibility to ascertain the fitness of the Products for Buyer's intended use. KEYENCE will not be responsible for any damages that may result from the use of the Products.
- (3) The Products and any samples ("Products/Samples") supplied to Buyer are not to be used internally in humans, for human transportation, as safety devices or fail-safe systems, unless their written specifications state otherwise. Should any Products/Samples be used in such a manner or misused in any way, KEYENCE assumes no responsibility, and additionally Buyer will indemnify KEYENCE and hold KEYENCE harmless from any liability or damage whatsoever arising out of any misuse of the Products/Samples.
- (4) OTHER THAN AS STATED HEREIN, THE PRODUCTS/SAMPLES ARE PROVIDED WITH NO OTHER WARRANTIES WHATSOEVER. ALL EXPRESS, IMPLIED, AND STATUTORY WARRANTIES, INCLUDING, WITHOUT LIMITATION, THE WARRANTIES OF MERCHANTABILITY, FITNESS FOR A PARTICULAR PURPOSE, AND NON-INFRINGEMENT OF PROPRIETARY RIGHTS, ARE EXPRESSLY DISCLAIMED. IN NO EVENT SHALL KEYENCE AND ITS AFFILIATED ENTITIES BE LIABLE TO ANY PERSON OR ENTITY FOR ANY DIRECT, INDIRECT, INCIDENTAL, PUNITIVE, SPECIAL OR CONSEQUENTIAL DAMAGES (INCLUDING, WITHOUT LIMITATION, ANY DAMAGES RESULTING FROM LOSS OF USE, BUSINESS INTERRUPTION, LOSS OF INFORMATION, LOSS OR INACCURACY OF DATA, LOSS OF PROFITS, LOSS OF SAVINGS, THE COST OF PROCUREMENT OF SUBSTITUTED GOODS, SERVICES OR TECHNOLOGIES, OR FOR ANY MATTER ARISING OUT OF OR IN CONNECTION WITH THE USE OR INABILITY TO USE THE PRODUCTS, EVEN IF KEYENCE OR ONE OF ITS AFFILIATED ENTITIES WAS ADVISED OF A POSSIBLE THIRD PARTY'S CLAIM FOR DAMAGES OR ANY OTHER CLAIM AGAINST BUYER. In some jurisdictions, some of the foregoing warranty disclaimers or damage limitations may not apply.

BUYER'S TRANSFER OBLIGATIONS:

If the Products/Samples purchased by Buyer are to be resold or delivered to a third party, Buyer must provide such third party with a copy of this document, all specifications, manuals, catalogs, leaflets and written information provided to Buyer pertaining to the Products/Samples.

E 1101-3

6 Detailed Settings

Hold down **[M]** for 3 seconds or more to enter the settings menu. Then, press **[M]** to change the item and press **[←/→]** to switch the setting value. Press **[M]** + **[←/→]** when an item is being set to return to the previous item.

A Power Modes Press **[←/→]** to select the value.

Select from eight power modes. The initial setting is FINE.

Mode	S-HSPD ^{*1}	HSPD	FINE	TURBO
Response time	23 μs	50 μs	250 μs	500 μs
Maximum displayable light intensity	9999			

Mode	SUPER	ULTRA	MEGA	TERA
Response time	1 ms	4 ms	16 ms	64 ms
Maximum displayable light intensity	9999			

B Switch L-on/D-on Press **[←/→]** to select the value.

- Light ON
- Dark ON

C Display Bar Press **[←/→]** to select the value.

- OFF
- ON

[END] <> ADVANCE Press **[←/→]** to select the value.

End **[M]** ADVANCE
Settings complete

D Detection Mode ^{*3} Press **[←/→]** to select the value.

Select from the following operation modes.

- Standard
- Preset
- Percent
- Zeroshift
- Area detection
- Area % Mode
- DATUM
- Rising edge
- Falling edge

E Output timer ^{*4} Press **[←/→]** to select the value.

F Ext. Input Press **[←/→]** to select the value.

This can only be used on types that support an external input. It is possible to select from the following values.

- OFF
- External Set
- Zero shift
- Reset
- LED OFF
- Pause
- Sleep

When connected to the multi-output unit FS-MC8N/P or the communication unit NU Series, this setting can be configured on types that do not support an external input.

G Saturate Cancel Press **[←/→]** to select the value.

H Attenuation Press **[←/→]** to select the value.

I Zero Shift Press **[←/→]** to select the value.

J Limit Detection ^{*4} Press **[←/→]** to select the value.

If Limit Detection is set to ON, a notification of a drop in light intensity is shown on the display when the light intensity drops due to factors such as dirt. With dual output types, it is also possible to output alarms to an external device. When connected to the multi-output unit FS-MC8N/P, it is possible to output alarms from the "common output" of the FS-MC8N/P even for types that do not support the alarm output.

K Auto Power Press **[←/→]** to select the value.

L Hysteresis Press **[←/→]** to select the value.

M Language Press **[←/→]** to select the value.

Select from English (initial setting), Japanese, Chinese, and German.

N Flip Display Press **[←/→]** to select the value.

O Sub Display Press **[←/→]** to select the value.

P ACT-R Press **[←/→]** to select the value.

Q Brightness Press **[←/→]** to select the value.

R ECO ^{*5} Press **[←/→]** to select the value.

S Initialize Press **[←/→]** to select the value.

T Custom Setting Press **[←/→]** to select the value.

U Interference ^{*5} ^{*7} Press **[←/→]** to select the value.

V Key Lock Method Press **[←/→]** to select the value.

W Display Gain ^{*5} Press **[←/→]** to select the value.

X IO-Link Mode ^{*8} Press **[←/→]** to select the value.

Y IO Data Format ^{*8} Press **[←/→]** to select the value.

Z I/O Selection ^{*8} Press **[←/→]** to select the value.

Settings complete

Output 2 setting

1 **2** When using a dual output type, if the output channel selection switch is set to the "2" side, output 2 can be set.

Hold down **[M]** for 3 seconds or more to enter setup mode.

a Second Output Press **[←/→]** to select the value.

b Switch L-On/D-On Press **[←/→]** to select the value.

c Output timer 2 Press **[←/→]** to select the value.

Settings complete

^{*1} When S-HSPD is selected for Power Modes Output 2 of dual output types is fixed to OFF.
IO-Link communication cannot be used (FS-N41C).
^{*2} This is 65535 when connected to an NU Series unit.
^{*3} When S-HSPD is selected for Power Modes Area detection, Area % Mode, DATUM, Rising edge, or Falling edge cannot be selected.
^{*4} This cannot be used when S-HSPD is selected for Power Modes.
^{*5} This cannot be used when S-HSPD or HSPD is selected for Power Modes.
^{*6} When S-HSPD is selected for Power Modes, FULL cannot be selected for the ECO function. The IO-Link communication cannot be used when FULL is selected for ECO (FS-N41C).
^{*7} This item is not displayed on the FS-N41C.
^{*8} This item is only displayed on the FS-N41C.

KEYENCE CORPORATION
1-3-14, Higashi-Nakajima, Higashi-Yodogawa-ku,
Osaka, 533-8555, Japan
PHONE: +81-6-6379-2211 www.keyence.com

AUSTRIA Ph: +43 22 36-3782 66-0	HONG KONG Ph: +852-3104-1010	NETHERLANDS Ph: +31 40 20 66 100	TAIWAN Ph: +886-2-2721-8080
BELGIUM Ph: +32 1 528 1222	HUNGARY Ph: +36 1 802 73 60	PHILIPPINES Ph: +63-(0)2-981-5000	THAILAND Ph: +66-2-369-2777
BRAZIL Ph: +55-11-3045-4011	INDIA Ph: +91-44-4963-0900	POLAND Ph: +48 71 36861 60	UK & IRELAND Ph: +44-1908-696900
CANADA Ph: +1-905-366-7655	INDONESIA Ph: +62-21-2966-0120	ROMANIA Ph: +40 269-232-808	USA Ph: +1-201-930-0100
CHINA Ph: +86-21-3357-1001	ITALY Ph: +39-02-6688220	SINGAPORE Ph: +65-6392-1011	VIETNAM Ph: +84-24-3772-5555
CZECH REPUBLIC Ph: +420 222 191 483	KOREA Ph: +82-31-789-4300	SLOVAKIA Ph: +421 2 5939 6461	
FRANCE Ph: +33 1 56 37 78 00	MALAYSIA Ph: +60-3-7883-2211	SLOVENIA Ph: +386 1-4701-666	
GERMANY Ph: +49 6102 36 89-0	MEXICO Ph: +52-55-8850-0100	SWITZERLAND Ph: +41 43-45577 30	

ASSEMBLY TITLE: BROKEN WEB / END OF WEB

DRAWING NO:

GENERAL FUNCTION:

- The broken web fault indicates that the labeler label stock has broken after the labeler pull roll. It consists of a reflective sensor and a reflector. The sensor is capable of reading clear or opaque label liner.

-When the broken web passes through the sensor, a signal is generated, that signal will shut the conveyor system down and light the red lamp on the stack lamp assembly.

-To reset the fault condition, rethread labels and press labeler run/pause to turn off the red light and place the labeler in run mode. The conveyor will restart and the labeling process will continue.

SET-UP AND ADJUSTMENTS:

- The sensor is set in light on operation mode. It is a retro-reflective operation. To set the sensor, refer to the following manufacture's instruction sheet.

- Ensure that all label material is removed from the sensor and reflector area for proper set up.

MAINTENANCE:

- See Maintenance Section

TROUBLESHOOTING:

- See Troubleshooting Section

ITEM	QTY	PART NO.	DESCRIPTION	PARENT ITEM
1	1	202192-002	CLEAR PRODUCT SENSOR	21606-012
2	1	203161-000	REFLECTOR	21606-012
3	1	252019-000	4 PIN MALE CONNECTOR	21606-012
4	1	A24242-000	SENSOR MTG. BLOCK	21606-012
5	1	A24243-000	REFLECTOR MTG. BLOCK	21606-012
6	2	A25772-000	POST, SENSOR	21606-012

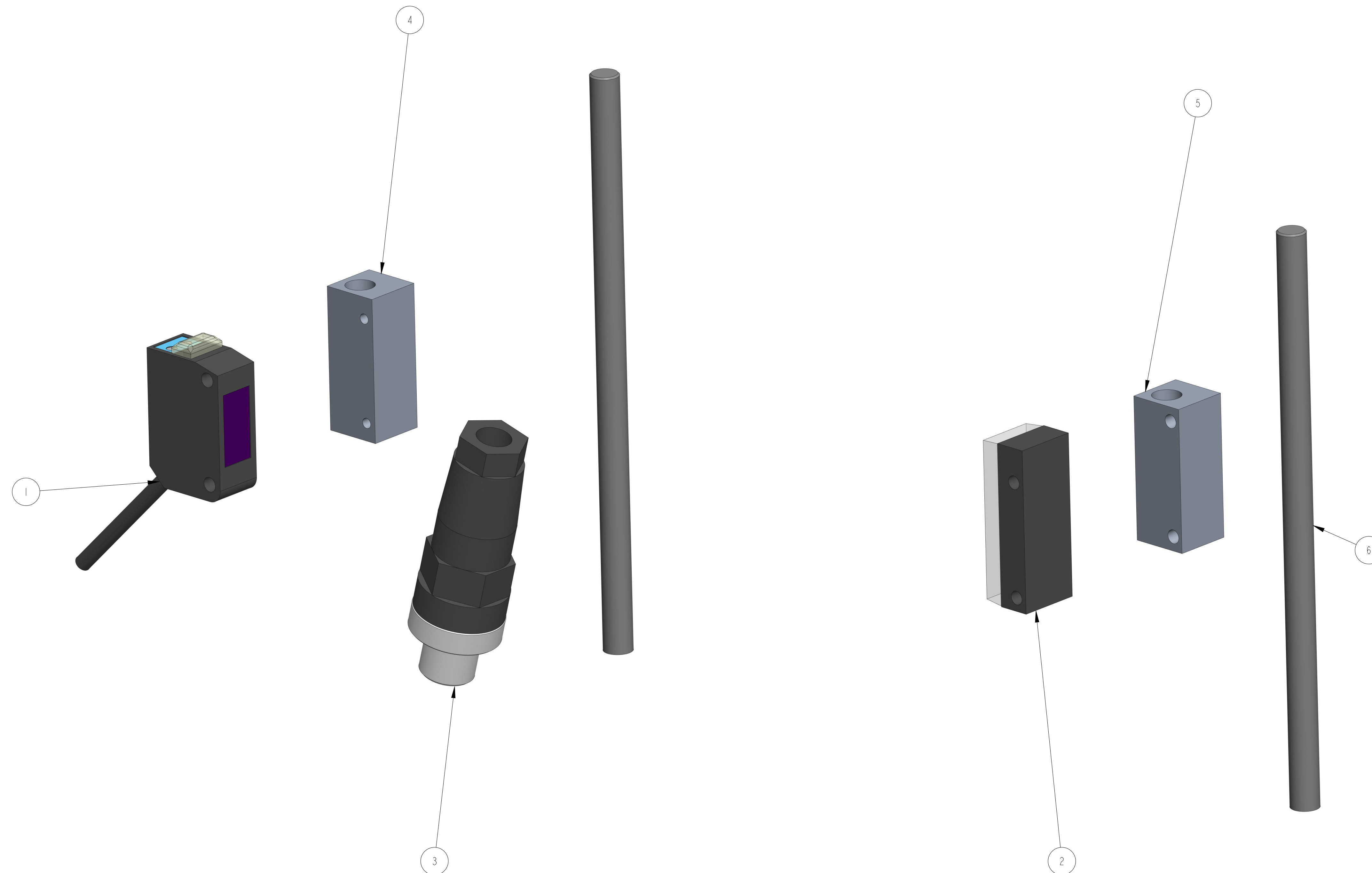

REV	DATE	DESCRIPTION	BY
A	11/11/24	NEW DRAWING	SEM

THIS IS A PRO-ENGINEER DOCUMENT AND MAY NOT BE MODIFIED MANUALLY

UNLESS OTHERWISE SPECIFIED DIMENSIONAL TOLERANCE	QUADREL LABELING SYSTEMS 7670 JENTHER DRIVE MENTOR, OHIO 44060 (440) 602-4700	SCALE: 2/1 DATE: 11/11/24 DRW BY: SEM CHK BY: CREO_CHK APPR BY:
.1 .01 .005 ANGLES ± 30°	BROKEN WEB/END OF WEB, PNP DUAL POSTS, USE PZ-G62P	
SURFACE FINISH 125 BREAK ALL EDGES .005/0.15 CORNER RADIUS .010/0.30	MAT'L	21606-012

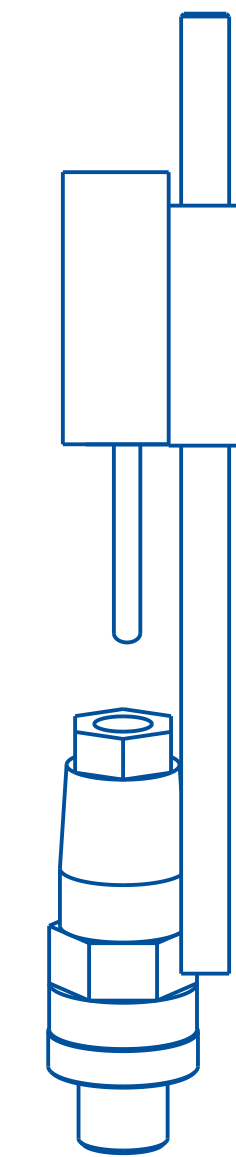
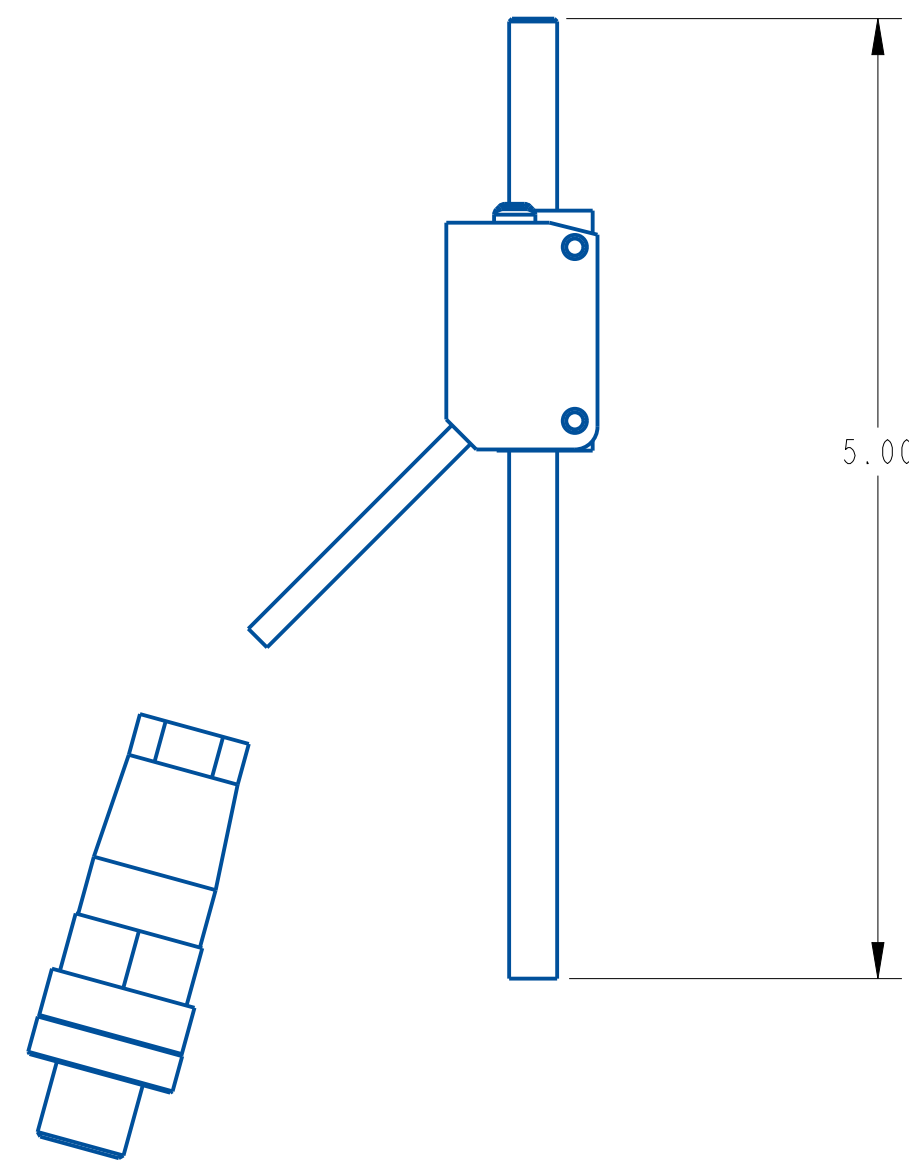
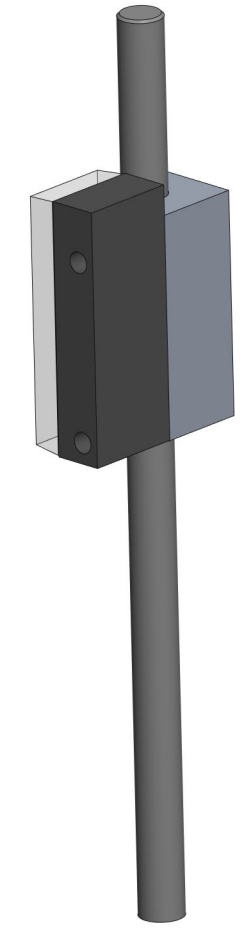
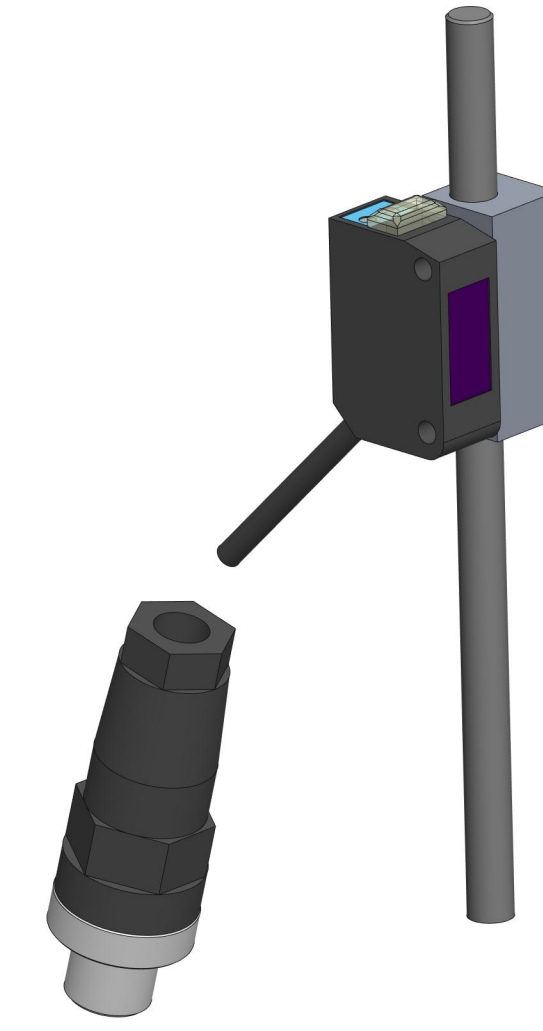
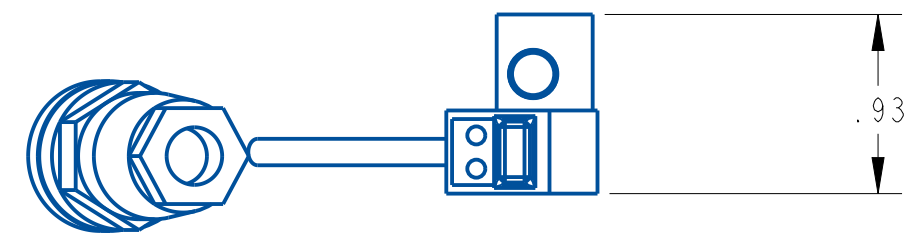

REV	DATE	DESCRIPTION	BY
A	11/11/24	NEW DRAWING	SEM

THIS IS A PRO-ENGINEER DOCUMENT AND MAY NOT BE MODIFIED MANUALLY

UNLESS OTHERWISE SPECIFIED
 DIMENSIONAL TOLERANCE
 .X ± .1
 .XX ± .01
 .XXX ± .005
 ANGLES ± .30°
 SURFACE FINISH 125
 BREAK ALL EDGES .005/.015
 CORNER RADIUS .010/.030
 ALL ANGLES ARE 90°

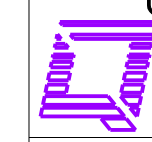

QUADREL LABELING SYSTEMS
 7670 JENTHER DRIVE
 MENTOR, OHIO 44060
 (440) 602-4700

BROKEN WEB/END OF WEB, PNP DUAL POSTS, USE PZ-G62P

MAT'L 21606-012

PZ-G Series

Instruction Manual

Read this manual thoroughly before using the product.
Keep this manual readily available for future reference.

96M11227



Safety precautions

- Avoid running the PZ-G cable along with power and high voltage lines, as this may cause interference and/or permanent damage.
- When using a commercially available switching regulator, ground its chassis grounding and earth grounding terminals.
- Do not use in locations where direct ambient light or external light directly shines on the light receiving surface.
- With retro-reflective type sensors, when detecting highly reflective materials (such as mirrored surfaces), stabilization may be difficult. To correct this, change the angle of the sensor head, or adjust the sensitivity.
- Avoid using power which exceeds the specifications for ripple (10% max)
- Avoid using excess force when rotating the operation mode selector switch (Light-on, Dark-on) and the sensitivity adjustment trimmer.
- This product is just intended to detect the object(s). Do not use this product for the purpose to protect a human body or a part of human body.
- This product is not intended for use as explosion-proof product. Do not use this product in a hazardous location and/or potentially explosive atmosphere.

Precautions on Regulations and Standards

UL Certificate

This product is an UL/C-UL Listed product.

- UL File No. E301717
- Category NRKH,NRKH7
- Enclosure Type 1 (Based on UL50)

Be sure to consider the following specifications when using this product as an UL/C-UL Listed Product.

- Use the power supply with Class 2 output defined in NFPA70 (NEC: National Electrical Code).
- Power supply/ Control input/ Control output circuits shall be connected to a single Class 2 source only.
- Use with the over current protection device which is rated 30V or more and not more than 1A.

Part Names

PZ-G5xN/G5xP

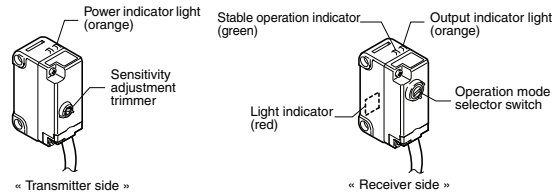

PZ-G5xB

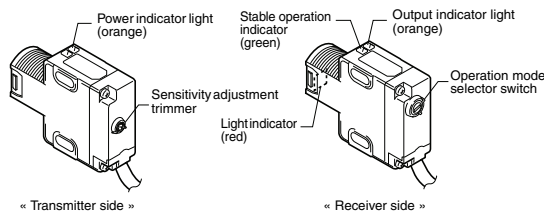

PZ-G4xN/G4xP/G10xN/G10xP/G6xN/G6xP

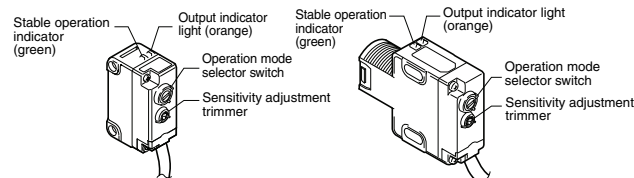

* The model name with "C" (PZ-GxxCx) is the connector type, and the model name with "E" (PZ-GxxEx) is the pigtail quick disconnect type.

Mounting Method

Side Mounting (Prepare M3 screws)

Tightening torque: 0.5 N·m or less

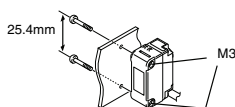

Tightening torque: 0.5 N·m or less

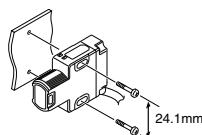

Mounting with the M18 nut (includes nut type)

The M18 nut is also available separately as OP-84225 (2 pcs. supplied).
Tightening torque: 1.0 N·m or less

Panel (5 mm or less)

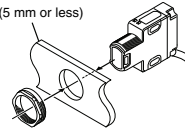

Panel cut size

$\phi 18.5 \pm 0.2$ mm

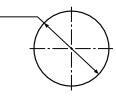

Note

- Mount the M18 nut (supplied) straight in. If mounted at an angle it cannot be tightened properly.
- When tightening the M18 nut (supplied), firmly hold the main body down. The case of the main body may be damaged if held in place with a tool such as pliers.
- When tightening the M18 nut (supplied), if excess force is applied to the nut with a tool such as pliers, it may bend it out of shape. Therefore, do not apply excess force.

Sensitivity Adjustment Method

Caution



Avoid using excess force when rotating the sensitivity adjustment trimmer and operation mode selector switch as it may cause damage.

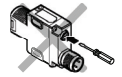

Operation mode selector switch

With the operation mode selector switch, you can select either the LIGHT-ON mode (L) or the DARK-ON (D) mode.



Reflective type (PZ-G41/G42/G101/G102/G10R/G10G/G10B Series)

The following assumes LIGHT-ON (L) is set.

Sequence	Adjustment method	Sensitivity adjustment trimmer
①	Position target in place. Slowly rotate the sensitivity trimmer from the MIN position towards the MAX position until the (orange) output indicator turns on (Position "A"). If the output indicator does not turn off, even at MIN, then MIN is considered Position "A".	A
②	Remove the target. Adjust the sensitivity trimmer from MIN towards MAX until the (orange) output indicator turns on (Position "B"). If the output indicator does not light up, the MAX position is considered Position "B".	B
③	Adjust the sensitivity trimmer to the midpoint between "A" and "B". Verify that the (green) stable operation light turns on with and without a target in place.	A B

Reference To use the sensor in DARK-ON mode, adjust the mode selector switch to "D".

Thrubeam type (PZ-G51/G52 Series) / Retro-reflective type (PZ-G61/G62 Series)

The following assumes DARK-ON (D) is set.

Sequence	Adjustment method	Sensitivity adjustment trimmer
①	Remove the target. Adjust the sensitivity trimmer to MAX. Mount the sensor heads in place so the (orange) output indicator turns off (on thrubeam models, the red light on the receiver face will turn on)	MIN MAX
②	Position target in place. Verify that the orange output indicator turns on (on thrubeam models, the red light on the receiver face will turn off). Adjust sensitivity lower if the output indicator does not turn on (or if the red light on the receiver face does not turn off on thrubeam models)	

Reference To use the sensor in LIGHT-ON mode, adjust the mode selector switch to "L".

I/O Circuit Diagram

PZ-G5xN/G5xP/G5xB (Transmitter side)

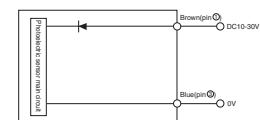

PZ-G5xN (Receiver side)/ G4xN/G10xN/G6xN

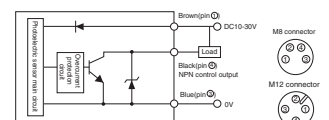

PZ-G5xP (Receiver side)/ G4xP/G10xP/G6xP

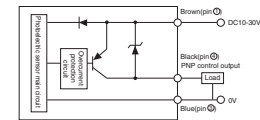

PZ-G5xB (Receiver side)/ G4xB/G10xB/G6xB

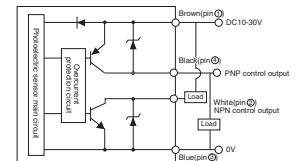

* The pin numbers represent those of the connector type / pigtail quick disconnect type. The model name with "C" (PZ-GxxCx) is the connector type, and the model name with "E" (PZ-GxxEx) is the pigtail quick disconnect type.

[PZ-GxxCN/GxxCP..... M8 connector
PZ-GxxCB/GxxEN/GxxEP..... M12 connector]

Indicators

The following describes each ON/OFF condition of indicator when LIGHT-ON (L) is set.

Reference When the DARK-ON (D) is set, the output indicator ON/OFF will reverse.

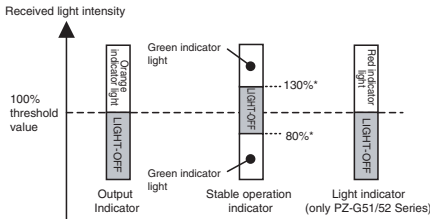

* For PZ-G62, the upper limit is 107% and the lower limit is 93%.

If the stable operation indicator turns off during operation, readjust or fine-adjust the sensitivity.

Mutual interference

- For reflective type / retro-reflective type sensors, mutual interference protection can be set for up to 2 units. However, when the sensors are mounted facing each other, change the angle of the sensor head to prevent light being emitted into each unit. (The mark detection type does not include the mutual interference function.)
- Mutual interference prevention can be set when mounting a polarizing filter attachment (optional with thru-beam type sensors) (If operation is unstable even after mounting the polarizing filter, slightly lower the sensitivity.)
- For more detailed information about mutual interference or attachment, see the PZ-G Series catalog or contact your nearest KEYENCE office.

Specifications

Type		Thru-beam		Reflective				Retro-reflective		Mark detection						
Configuration	Cable shape	Output mode	Normal	High-power	Diffuse-reflective Long-detecting distance	Diffuse-reflective Short-detecting distance	Narrow-view reflective	Definite reflective	Long detecting distance (with P.R.O. function)	Transparent target detection (without P.R.O. function)	Red	Green	Blue			
Rectangular	Cable	NPN	PZ-G51N	PZ-G52N	PZ-G41N	PZ-G42N	PZ-G101N	PZ-G102N	PZ-G61N	PZ-G62N						
		PNP	PZ-G51P	PZ-G52P	PZ-G41P	PZ-G42P	PZ-G101P	PZ-G102P	PZ-G61P	PZ-G62P						
	M8 connector	NPN	PZ-G51CN	PZ-G52CN	PZ-G41CN	PZ-G42CN	PZ-G101CN	PZ-G102CN	PZ-G61CN	PZ-G62CN				PZ-G10RCN	PZ-G10GCN	PZ-G10BCN
		PNP	PZ-G51CP	PZ-G52CP	PZ-G41CP	PZ-G42CP	PZ-G101CP	PZ-G102CP	PZ-G61CP	PZ-G62CP				PZ-G10RCP	PZ-G10GCP	PZ-G10BCP
Nut	Cable	NPN	PZ-G51EN	PZ-G52EN	PZ-G41EN	PZ-G42EN	PZ-G101EN	PZ-G102EN	PZ-G61EN	PZ-G62EN						
		PNP	PZ-G51EP	PZ-G52EP	PZ-G41EP	PZ-G42EP	PZ-G101EP	PZ-G102EP	PZ-G61EP	PZ-G62EP						
Nut	M12 connector	Bipolar	PZ-G51B	PZ-G52B	PZ-G41B	PZ-G42B	PZ-G101B	PZ-G102B	PZ-G61B	PZ-G62B						
		(NPN+PNP)	PZ-G51CB	PZ-G52CB	PZ-G41CB	PZ-G42CB	PZ-G101CB	PZ-G102CB	PZ-G61CB	PZ-G62CB						
Detecting distance ¹			20 m	40 m	1 m (30 x 30 cm white mat paper)	300 mm (10 x 10 cm white mat paper)	200 mm	5 to 45 mm	0.1 to 4.2 m (when R-2L reflector is used)	0.1 to 1 m (when R-2L reflector is used)	8 to 15 mm					
Spot diameter			-	-	-	-	Approx. φ 5 mm (when the detecting distance is 100 mm)	Approx. φ 2 mm (when the detecting distance is 40 mm)	-	-	Approx. 1.5 x 4 mm (when the detecting distance is 10 mm)					
Light source (LED)			Red LED	Infrared LED x 2	Red LED				Infrared LED		Red LED	Green LED	Blue LED			
Sensitivity adjustment		1-turn trimmer (230 degrees)														
Response time		500 μs										50 μs				
Operation mode		LIGHT-ON/DARK-ON, trimmer-selectable														
Indicator (LED)		Transmitter: power (orange) Receiver: output (orange), stable operation (green), light (red)			Output (orange), stable operation (green)											
Control output		Open-collector 100 mA max. (30 V max.), Residual voltage 1 V max.														
Protection circuit		Reverse-polarity protection, over-current protection, output surge absorber														
Ratings	Power voltage	10 to 30 VDC, Ripple (P-P): ±10% max, Class 2.														
	Current consumption	Transmitter: 20 mA max. Receiver: 28 mA max.	Transmitter: 25 mA max. Receiver: 28 mA max.	34 mA max.												
Environmental resistance	Enclosure rating	IEC/JEM: IP67 / NEMA: 4X, 6, 12 / DIN: IP69K														
	Ambient light	Incandescent lamp: 5,000 (lx) max, Sunlight: 20,000 (lx) max.														
	Ambient temperature	-20 °C to +55 °C (No freezing)														
	Relative humidity	35 to 85 % RH (No condensation)														
	Vibration resistance	10 to 55 Hz, 1.5 mm double amplitude in X, Y, Z directions, 2 hours each														
Shock resistance	1000 m/s ² in X, Y, Z directions, 6 times each															
Interference prevention		2 units (when polarizing filter attachment is used)		2 units (with the automatic different cycle function)												
Material		Case, M18 nut (nut type only): reinforced glass polybutylene terephthalate (PBT), Trimmer: reinforced glass polyamide (PA) Cable (Cable type / pigtail quick disconnect type only): Polyvinyl chloride (PVC), Screw (Case connection): Steel, zinc-nickel plated, Packing (Case connection): Nitrile-butadiene rubber (NBR) Connector (pigtail quick disconnect type only): Brass-nickel plated, Polybutylene terephthalate (PBT), Polyvinyl chloride (PVC)														
Lens cover		Polyarylate (PAR)				Acrylic plastic (PMMA)			Polyarylate (PAR)							
Tightening torque		Rectangular type (side screw part): 0.5 N·m max. Nut type (front M18 part): 1.0 N·m max., (side slot part): 0.5 N·m max.														
Accessory ²		Instruction manual, M18 nut x 2 (nut thru-beam type), M18 nut x 1 (other nut types)														
Weight		Rectangular cable type: Approx. 60 g (Approx. 50 g for thru-beam transmitter), Rectangular M8 connector type: Approx. 10 g, rectangular M12 pigtail quick disconnect type: Approx. 30 g Nut type cable type: Approx. 65 g (Approx. 55 g for thru-beam transmitter), Nut type M12 connector type: Approx. 15 g														

¹ The detection distance is measured with the maximum sensitivity.

² The cable for the connector type / pigtail quick disconnect type is sold separately. The reflector for the retro-reflective type is sold separately.

WARRANTY

KEYENCE products are strictly factory-inspected. However, in the event of a failure, contact your nearest KEYENCE office with details of the failure.

1. WARRANTY PERIOD

The warranty period shall be for one year from the date that the product has been delivered to the location specified by the purchaser.

2. WARRANTY SCOPE

(1) If a failure attributable to KEYENCE occurs within the abovementioned warranty period, we will repair the product, free of charge. However, the following cases shall be excluded from the warranty scope.

- Any failure resulting from improper conditions, improper environments, improper handling, or improper usage other than described in the instruction manual, the user's manual, or the specifications specifically arranged between the purchaser and KEYENCE.
- Any failure resulting from factors other than a defect of our product, such as the purchaser's equipment or the design of the purchaser's software.
- Any failure resulting from modifications or repairs carried out by any person other than KEYENCE staff.
- Any failure that can certainly be prevented when the expendable part(s) is maintained or replaced correctly as described in the instruction manual, the user's manual, etc.
- Any failure caused by a factor that cannot be foreseen at a scientific/technical level at the time when the product has been shipped from KEYENCE.
- Any disaster such as fire, earthquake, and flood, or any other external factor, such as abnormal voltage, for which we are not liable.

(2) The warranty scope is limited to the extent set forth in item (1), and KEYENCE assumes no liability for any purchaser's secondary damage (damage of equipment, loss of opportunities, loss of profits, etc.) or any other damage resulting from a failure of our product.

3. PRODUCT APPLICABILITY

KEYENCE products are designed and manufactured as general-purpose products for general industries.

Therefore, our products are not intended for the applications below and are not applicable to them. If, however, the purchaser consults with us in advance regarding the employment of our product, understands the specifications, ratings, and performance of the product on their own responsibility, and takes necessary safety measures, the product may be applied. In this case, the warranty scope shall be the same as above.

- Facilities where the product may greatly affect human life or property, such as nuclear power plants, aviation, railroads, ships, motor vehicles, or medical equipment
- Public utilities such as electricity, gas, or water services
- Usage outdoors, under similar conditions or in similar environments

E 1040-1

KEYENCE CORPORATION

1-3-14, Higashi-Nakajima, Higashi-Yodogawa-ku,
Osaka, 533-8555, Japan

PHONE: +81-6-6379-2211 www.keyence.com

Specifications are subject to change without notice.

A7WW1-MAN-0069

Copyright (c) 2010 KEYENCE CORPORATION. All rights reserved.

11227E 1070-1 96M11227J

Printed in Japan



ASSEMBLY TITLE: BROKEN WEB / END OF WEB

DRAWING NO:

GENERAL FUNCTION:

- The broken web fault indicates that the labeler label stock has broken after the labeler pull roll. It consists of a reflective sensor and a reflector. The sensor is capable of reading clear or opaque label liner.

-When the broken web passes through the sensor, a signal is generated, that signal will shut the conveyor system down and light the red lamp on the stack lamp assembly.

-To reset the fault condition, rethread labels and press labeler run/pause to turn off the red light and place the labeler in run mode. The conveyor will restart and the labeling process will continue.

SET-UP AND ADJUSTMENTS:

- The sensor is set in light on operation mode. It is a retro-reflective operation. To set the sensor, refer to the following manufacture's instruction sheet.

- Ensure that all label material is removed from the sensor and reflector area for proper set up.

MAINTENANCE:

- See Maintenance Section

TROUBLESHOOTING:

- See Troubleshooting Section

ITEM	QTY	PART NO.	DESCRIPTION	PARENT ITEM
1	1	202192-002	CLEAR PRODUCT SENSOR	21606-013
2	1	203161-000	REFLECTOR	21606-013
3	1	252019-000	4 PIN MALE CONNECTOR	21606-013
4	1	A24241-000	MOUNTING BLOCK	21606-013
5	1	A24242-000	SENSOR MTG. BLOCK	21606-013
6	1	A24243-000	REFLECTOR MTG. BLOCK	21606-013
7	2	A24244-000	SUPPORT ROD WITH FLAT	21606-013

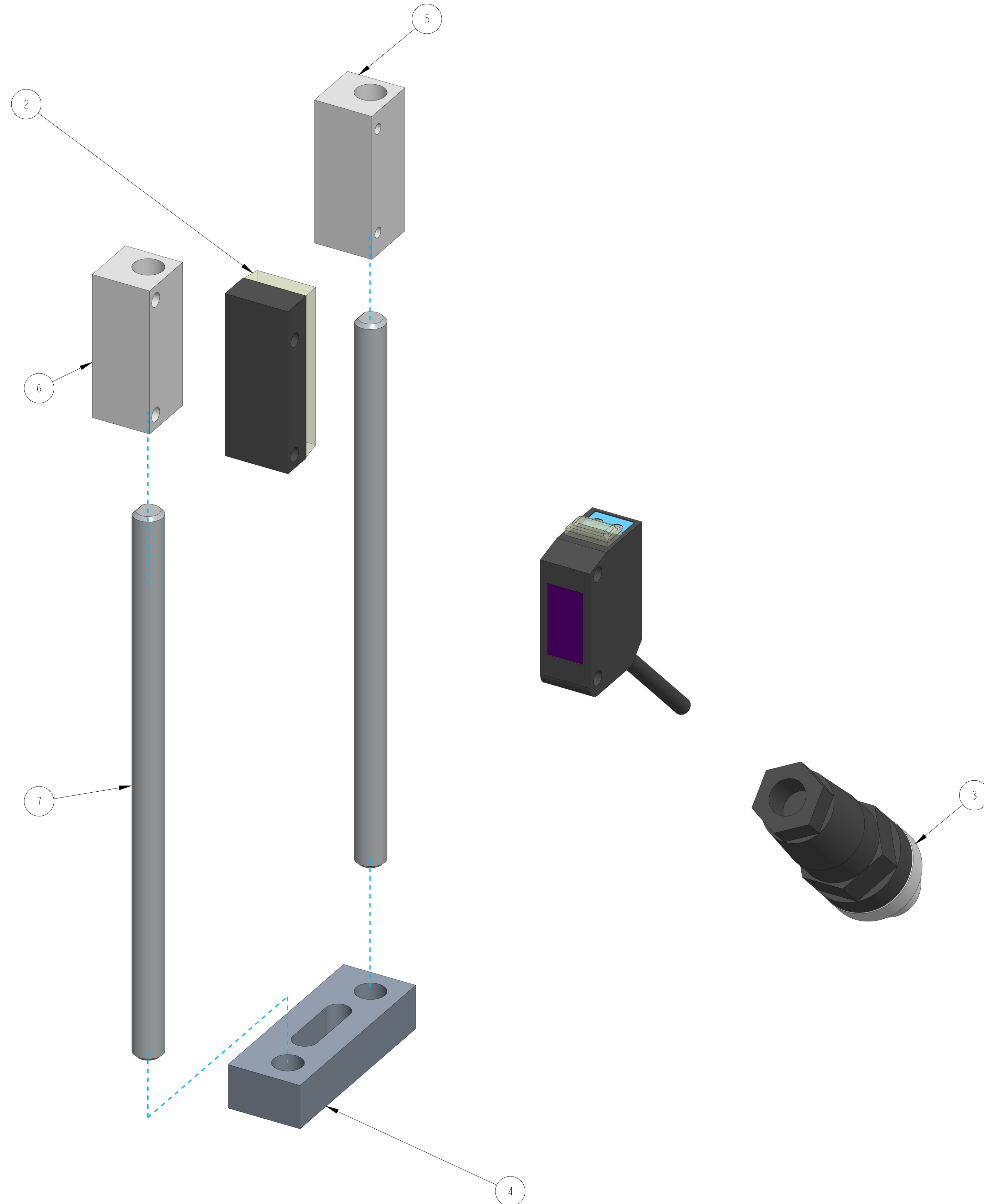

REV	DATE	DESCRIPTION	BY
A	11/11/24	NEW DRAWING	SEM

THIS IS A PRO-ENGINEER DOCUMENT AND MAY NOT BE MODIFIED MANUALLY

UNLESS OTHERWISE SPECIFIED DIMENSIONAL TOLERANCE .1 .01 .005 ANGLES ± 30° SURFACE FINISH 125 BREAK ALL EDGES .005/.015 CORNER RADIUS .010/.030	QUADREL LABELING SYSTEMS 7670 JENTHER DRIVE MENTOR, OHIO 44060 (440) 602-4700	SCALE: 2/1 DATE: 11/11/24 DRW BY: SEM CHK BY: &CREO_CHK APPR BY:
--	---	--

BROKEN WEB/END OF WEB, PNP SINGLE BASE, USE PZ-G62P

MAT'L	21606-013
-------	-----------

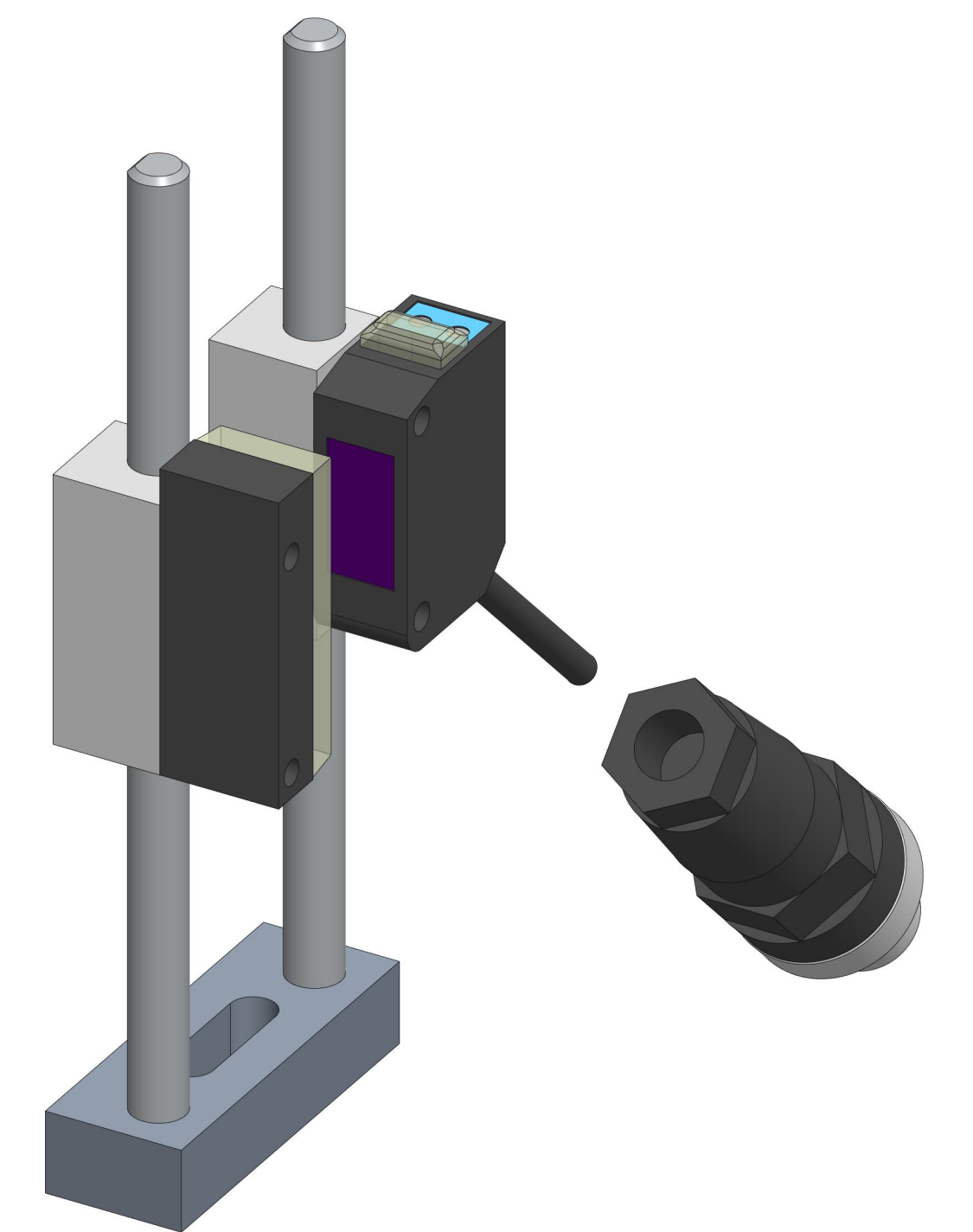
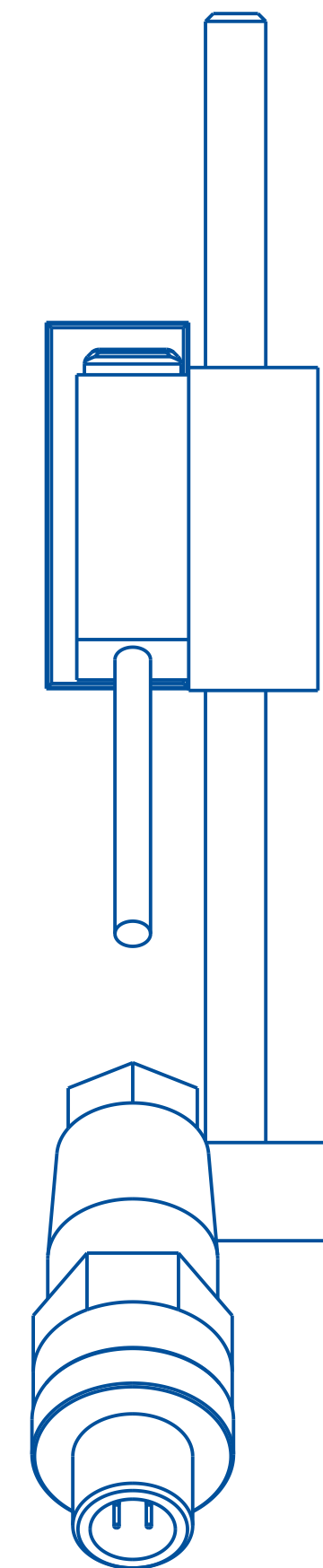
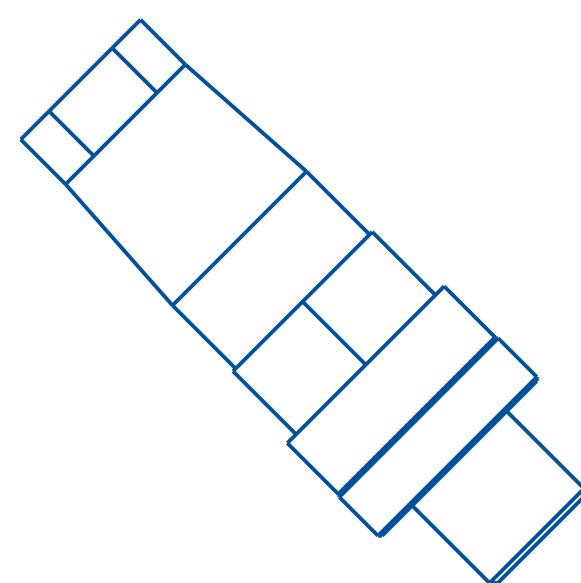
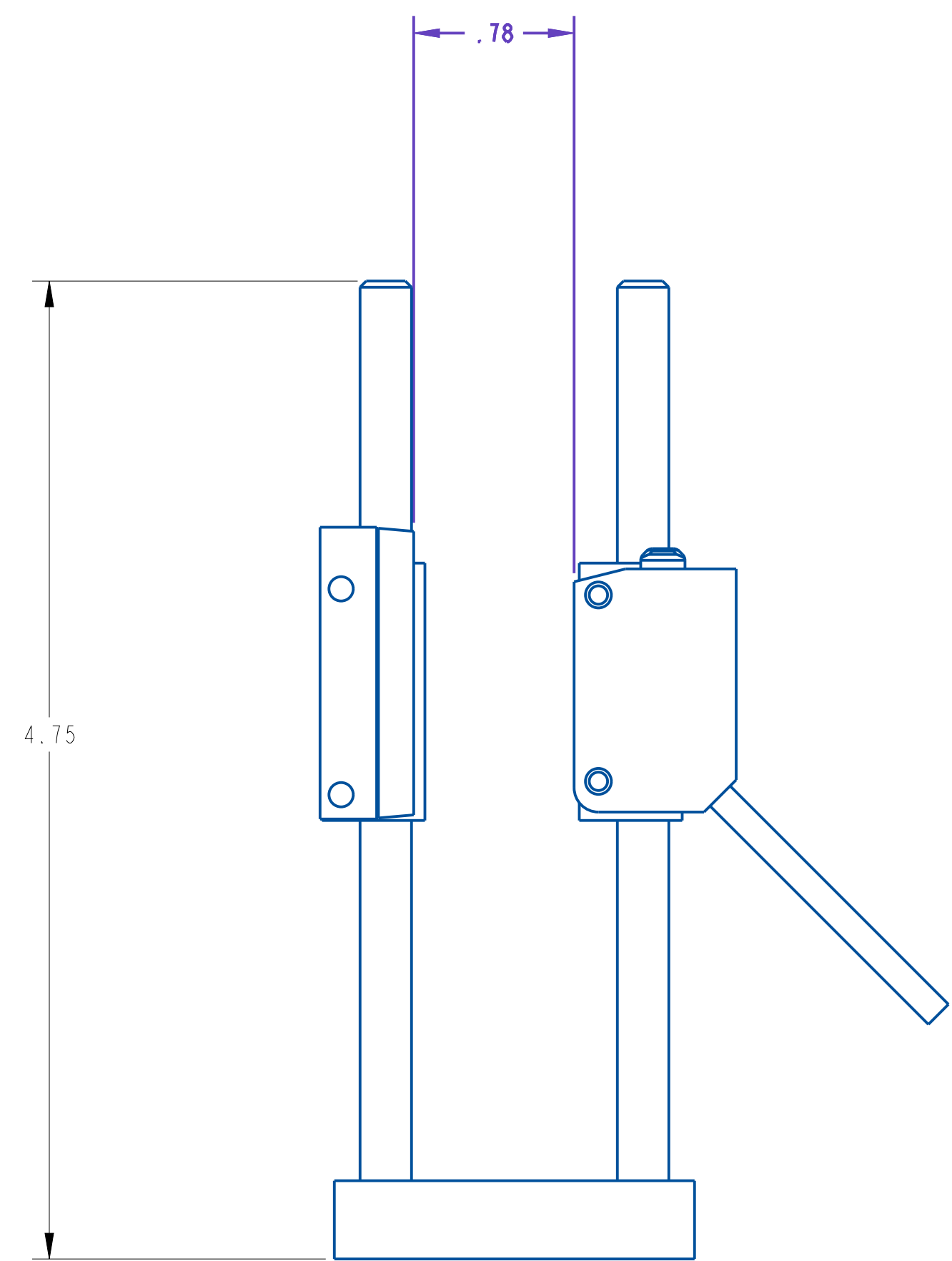
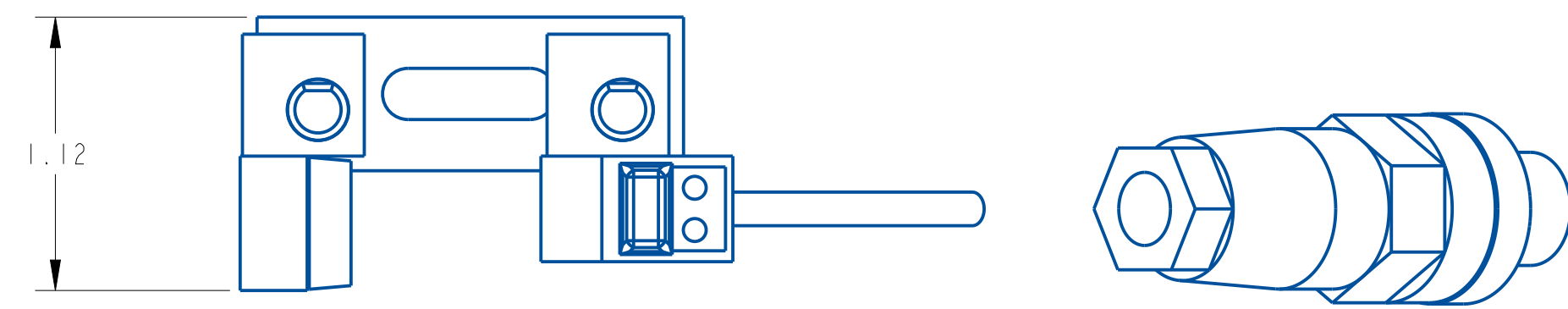

REV	DATE	DESCRIPTION	BY
A	11/11/24	NEW DRAWING	SEM

THIS IS A PRO-ENGINEER DOCUMENT AND MAY NOT BE MODIFIED MANUALLY

UNLESS OTHERWISE SPECIFIED
DIMENSIONAL TOLERANCE

X ± .1
XX ± .01
XXX ± .005
ANGLES ± .30°

SURFACE FINISH 125
BREAK ALL EDGES .005/.015
CORNER RADIUS .010/.030
ALL ANGLES ARE 90°

QUADREL LABELING SYSTEMS
7670 JENTHER DRIVE
MENTOR, OHIO 44060
(440) 602-4700

SCALE: 3/2
DATE: 11/11/24
DRW BY: SEM
CHK BY: CREO_CHK
APPR BY:

BROKEN WEB/END OF WEB, PNP SINGLE BASE, USE PZ-G62P

MAT'L

21606-013

PZ-G Series

Instruction Manual

Read this manual thoroughly before using the product.
Keep this manual readily available for future reference.

96M11227



Safety precautions

- Avoid running the PZ-G cable along with power and high voltage lines, as this may cause interference and/or permanent damage.
- When using a commercially available switching regulator, ground its chassis grounding and earth grounding terminals.
- Do not use in locations where direct ambient light or external light directly shines on the light receiving surface.
- With retro-reflective type sensors, when detecting highly reflective materials (such as mirrored surfaces), stabilization may be difficult. To correct this, change the angle of the sensor head, or adjust the sensitivity.
- Avoid using power which exceeds the specifications for ripple (10% max)
- Avoid using excess force when rotating the operation mode selector switch (Light-on, Dark-on) and the sensitivity adjustment trimmer.
- This product is just intended to detect the object(s). Do not use this product for the purpose to protect a human body or a part of human body.
- This product is not intended for use as explosion-proof product. Do not use this product in a hazardous location and/or potentially explosive atmosphere.

Precautions on Regulations and Standards

UL Certificate

This product is an UL/C-UL Listed product.

- UL File No. E301717
- Category NRKH,NRKH7
- Enclosure Type 1 (Based on UL50)

Be sure to consider the following specifications when using this product as an UL/C-UL Listed Product.

- Use the power supply with Class 2 output defined in NFPA70 (NEC: National Electrical Code).
- Power supply/ Control input/ Control output circuits shall be connected to a single Class 2 source only.
- Use with the over current protection device which is rated 30V or more and not more than 1A.

Part Names

PZ-G5xN/G5xP

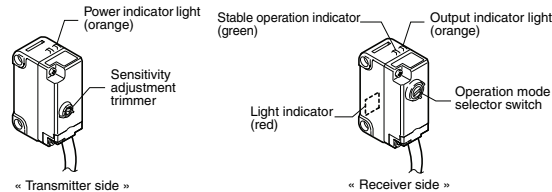

PZ-G5xB

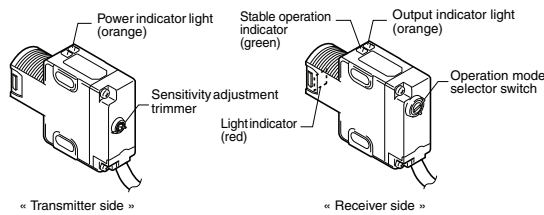

PZ-G4xN/G4xP/G10xN/G10xP/G6xN/G6xP

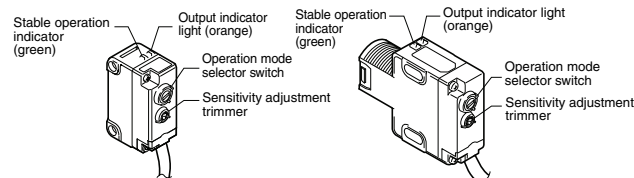

* The model name with "C" (PZ-GxxCx) is the connector type, and the model name with "E" (PZ-GxxEx) is the pigtail quick disconnect type.

Mounting Method

Side Mounting (Prepare M3 screws)

Tightening torque: 0.5 N·m or less

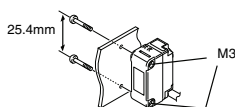

Tightening torque: 0.5 N·m or less

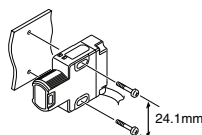

Mounting with the M18 nut (includes nut type)

The M18 nut is also available separately as OP-84225 (2 pcs. supplied).
Tightening torque: 1.0 N·m or less

Panel (5 mm or less)

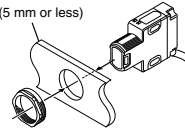

Panel cut size

$\phi 18.5 \pm 0.2$ mm

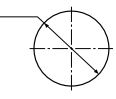

Note

- Mount the M18 nut (supplied) straight in. If mounted at an angle it cannot be tightened properly.
- When tightening the M18 nut (supplied), firmly hold the main body down. The case of the main body may be damaged if held in place with a tool such as pliers.
- When tightening the M18 nut (supplied), if excess force is applied to the nut with a tool such as pliers, it may bend it out of shape. Therefore, do not apply excess force.

Sensitivity Adjustment Method

Caution



Avoid using excess force when rotating the sensitivity adjustment trimmer and operation mode selector switch as it may cause damage.

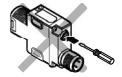

Operation mode selector switch

With the operation mode selector switch, you can select either the LIGHT-ON mode (L) or the DARK-ON (D) mode.



Reflective type (PZ-G41/G42/G101/G102/G10R/G10G/G10B Series)

The following assumes LIGHT-ON (L) is set.

Sequence	Adjustment method	Sensitivity adjustment trimmer
①	Position target in place. Slowly rotate the sensitivity trimmer from the MIN position towards the MAX position until the (orange) output indicator turns on (Position "A"). If the output indicator does not turn off, even at MIN, then MIN is considered Position "A".	
②	Remove the target. Adjust the sensitivity trimmer from MIN towards MAX until the (orange) output indicator turns on (Position "B"). If the output indicator does not light up, the MAX position is considered Position "B".	
③	Adjust the sensitivity trimmer to the midpoint between "A" and "B". Verify that the (green) stable operation light turns on with and without a target in place.	

Reference To use the sensor in DARK-ON mode, adjust the mode selector switch to "D".

Thrubeam type (PZ-G51/G52 Series) / Retro-reflective type (PZ-G61/G62 Series)

The following assumes DARK-ON (D) is set.

Sequence	Adjustment method	Sensitivity adjustment trimmer
①	Remove the target. Adjust the sensitivity trimmer to MAX. Mount the sensor heads in place so the (orange) output indicator turns off (on thrubeam models, the red light on the receiver face will turn on)	
②	Position target in place. Verify that the orange output indicator turns on (on thrubeam models, the red light on the receiver face will turn off). Adjust sensitivity lower if the output indicator does not turn on (or if the red light on the receiver face does not turn off on thrubeam models)	

Reference To use the sensor in LIGHT-ON mode, adjust the mode selector switch to "L".

I/O Circuit Diagram

PZ-G5xN/G5xP/G5xB (Transmitter side)

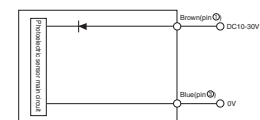

PZ-G5xN (Receiver side)/ G4xN/G10xN/G6xN

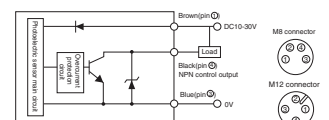

PZ-G5xP (Receiver side)/ G4xP/G10xP/G6xP

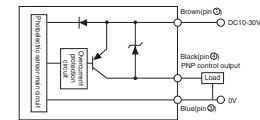

PZ-G5xB (Receiver side)/ G4xB/G10xB/G6xB

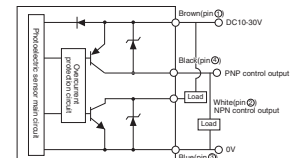

* The pin numbers represent those of the connector type / pigtail quick disconnect type. The model name with "C" (PZ-GxxCx) is the connector type, and the model name with "E" (PZ-GxxEx) is the pigtail quick disconnect type.

[PZ-GxxCN/GxxCP..... M8 connector
PZ-GxxCB/GxxEN/GxxEP..... M12 connector]

Indicators

The following describes each ON/OFF condition of indicator when LIGHT-ON (L) is set.

Reference When the DARK-ON (D) is set, the output indicator ON/OFF will reverse.

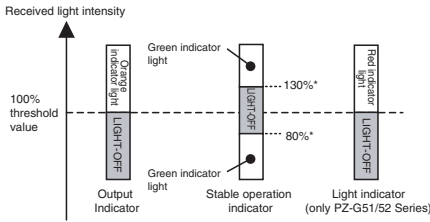

* For PZ-G62, the upper limit is 107% and the lower limit is 93%.

If the stable operation indicator turns off during operation, readjust or fine-adjust the sensitivity.

Mutual interference

- For reflective type / retro-reflective type sensors, mutual interference protection can be set for up to 2 units. However, when the sensors are mounted facing each other, change the angle of the sensor head to prevent light being emitted into each unit. (The mark detection type does not include the mutual interference function.)
- Mutual interference prevention can be set when mounting a polarizing filter attachment (optional with thru-beam type sensors) (If operation is unstable even after mounting the polarizing filter, slightly lower the sensitivity.)
- For more detailed information about mutual interference or attachment, see the PZ-G Series catalog or contact your nearest KEYENCE office.

Specifications

Type		Thru-beam		Reflective				Retro-reflective		Mark detection				
Configuration	Cable shape	Output mode	Normal	High-power	Diffuse-reflective Long-detecting distance	Diffuse-reflective Short-detecting distance	Narrow-view reflective	Definite reflective	Long detecting distance (with P.R.O. function)	Transparent target detection (without P.R.O. function)	Red	Green	Blue	
Rectangular	Cable	NPN	PZ-G51N	PZ-G52N	PZ-G41N	PZ-G42N	PZ-G101N	PZ-G102N	PZ-G61N	PZ-G62N				
		PNP	PZ-G51P	PZ-G52P	PZ-G41P	PZ-G42P	PZ-G101P	PZ-G102P	PZ-G61P	PZ-G62P				
	M8 connector	NPN	PZ-G51CN	PZ-G52CN	PZ-G41CN	PZ-G42CN	PZ-G101CN	PZ-G102CN	PZ-G61CN	PZ-G62CN	PZ-G10RCN	PZ-G10GCN	PZ-G10BCN	
		PNP	PZ-G51CP	PZ-G52CP	PZ-G41CP	PZ-G42CP	PZ-G101CP	PZ-G102CP	PZ-G61CP	PZ-G62CP	PZ-G10RCP	PZ-G10GCP	PZ-G10BCP	
Nut	Cable	NPN	PZ-G51EN	PZ-G52EN	PZ-G41EN	PZ-G42EN	PZ-G101EN	PZ-G102EN	PZ-G61EN	PZ-G62EN				
		PNP	PZ-G51EP	PZ-G52EP	PZ-G41EP	PZ-G42EP	PZ-G101EP	PZ-G102EP	PZ-G61EP	PZ-G62EP				
Nut	M12 connector	Bipolar	PZ-G51B	PZ-G52B	PZ-G41B	PZ-G42B	PZ-G101B	PZ-G102B	PZ-G61B	PZ-G62B				
		(NPN+PNP)	PZ-G51CB	PZ-G52CB	PZ-G41CB	PZ-G42CB	PZ-G101CB	PZ-G102CB	PZ-G61CB	PZ-G62CB				
Detecting distance ¹			20 m	40 m	1 m (30 x 30 cm white mat paper)	300 mm (10 x 10 cm white mat paper)	200 mm	5 to 45 mm	0.1 to 4.2 m (when R-2L reflector is used)	0.1 to 1 m (when R-2L reflector is used)	8 to 15 mm			
Spot diameter			-	-	-	-	Approx. φ 5 mm (when the detecting distance is 100 mm)	Approx. φ 2 mm (when the detecting distance is 40 mm)	-	-	Approx. 1.5 x 4 mm (when the detecting distance is 10 mm)			
Light source (LED)			Red LED	Infrared LED x 2	Red LED				Infrared LED		Red LED	Green LED	Blue LED	
Sensitivity adjustment		1-turn trimmer (230 degrees)												
Response time		500 μs										50 μs		
Operation mode		LIGHT-ON/DARK-ON, trimmer-selectable												
Indicator (LED)		Transmitter: power (orange) Receiver: output (orange), stable operation (green), light (red)			Output (orange), stable operation (green)									
Control output		Open-collector 100 mA max. (30 V max.), Residual voltage 1 V max.												
Protection circuit		Reverse-polarity protection, over-current protection, output surge absorber												
Ratings	Power voltage	10 to 30 VDC, Ripple (P-P): ±10% max, Class 2.												
	Current consumption	Transmitter: 20 mA max. Receiver: 28 mA max.	Transmitter: 25 mA max. Receiver: 28 mA max.	34 mA max.										
Environmental resistance	Enclosure rating	IEC/JEM: IP67 / NEMA: 4X, 6, 12 / DIN: IP69K												
	Ambient light	Incandescent lamp: 5,000 (lx) max, Sunlight: 20,000 (lx) max.												
	Ambient temperature	-20 °C to +55 °C (No freezing)												
	Relative humidity	35 to 85 % RH (No condensation)												
	Vibration resistance	10 to 55 Hz, 1.5 mm double amplitude in X, Y, Z directions, 2 hours each												
Shock resistance	1000 m/s ² in X, Y, Z directions, 6 times each													
Interference prevention		2 units (when polarizing filter attachment is used)		2 units (with the automatic different cycle function)										
Material		Case, M18 nut (nut type only): reinforced glass polybutylene terephthalate (PBT), Trimmer: reinforced glass polyamide (PA) Cable (Cable type / pigtail quick disconnect type only): Polyvinyl chloride (PVC), Screw (Case connection): Steel, zinc-nickel plated, Packing (Case connection): Nitrile-butadiene rubber (NBR) Connector (pigtail quick disconnect type only): Brass-nickel plated, Polybutylene terephthalate (PBT), Polyvinyl chloride (PVC)												
Lens cover		Polyarylate (PAR)				Acrylic plastic (PMMA)			Polyarylate (PAR)					
Tightening torque		Rectangular type (side screw part): 0.5 N·m max. Nut type (front M18 part): 1.0 N·m max., (side slot part): 0.5 N·m max.												
Accessory ²		Instruction manual, M18 nut x 2 (nut thru-beam type), M18 nut x 1 (other nut types)												
Weight		Rectangular cable type: Approx. 60 g (Approx. 50 g for thru-beam transmitter), Rectangular M8 connector type: Approx. 10 g, rectangular M12 pigtail quick disconnect type: Approx. 30 g Nut type cable type: Approx. 65 g (Approx. 55 g for thru-beam transmitter), Nut type M12 connector type: Approx. 15 g												

¹ The detection distance is measured with the maximum sensitivity.

² The cable for the connector type / pigtail quick disconnect type is sold separately. The reflector for the retro-reflective type is sold separately.

WARRANTY

KEYENCE products are strictly factory-inspected. However, in the event of a failure, contact your nearest KEYENCE office with details of the failure.

1. WARRANTY PERIOD

The warranty period shall be for one year from the date that the product has been delivered to the location specified by the purchaser.

2. WARRANTY SCOPE

(1) If a failure attributable to KEYENCE occurs within the abovementioned warranty period, we will repair the product, free of charge. However, the following cases shall be excluded from the warranty scope.

- Any failure resulting from improper conditions, improper environments, improper handling, or improper usage other than described in the instruction manual, the user's manual, or the specifications specifically arranged between the purchaser and KEYENCE.
- Any failure resulting from factors other than a defect of our product, such as the purchaser's equipment or the design of the purchaser's software.
- Any failure resulting from modifications or repairs carried out by any person other than KEYENCE staff.
- Any failure that can certainly be prevented when the expendable part(s) is maintained or replaced correctly as described in the instruction manual, the user's manual, etc.
- Any failure caused by a factor that cannot be foreseen at a scientific/technical level at the time when the product has been shipped from KEYENCE.
- Any disaster such as fire, earthquake, and flood, or any other external factor, such as abnormal voltage, for which we are not liable.

(2) The warranty scope is limited to the extent set forth in item (1), and KEYENCE assumes no liability for any purchaser's secondary damage (damage of equipment, loss of opportunities, loss of profits, etc.) or any other damage resulting from a failure of our product.

3. PRODUCT APPLICABILITY

KEYENCE products are designed and manufactured as general-purpose products for general industries.

Therefore, our products are not intended for the applications below and are not applicable to them. If, however, the purchaser consults with us in advance regarding the employment of our product, understands the specifications, ratings, and performance of the product on their own responsibility, and takes necessary safety measures, the product may be applied. In this case, the warranty scope shall be the same as above.

- Facilities where the product may greatly affect human life or property, such as nuclear power plants, aviation, railroads, ships, motor vehicles, or medical equipment
- Public utilities such as electricity, gas, or water services
- Usage outdoors, under similar conditions or in similar environments

E 1040-1

KEYENCE CORPORATION

1-3-14, Higashi-Nakajima, Higashi-Yodogawa-ku,
Osaka, 533-8555, Japan

PHONE: +81-6-6379-2211 www.keyence.com

Specifications are subject to change without notice.

A7WW1-MAN-0069

Copyright (c) 2010 KEYENCE CORPORATION. All rights reserved.

11227E 1070-1 96M11227J

Printed in Japan



System

ASSEMBLY TITLE: FRAME ASSEMBLY

GENERAL FUNCTION:

- Provides solid mounting for labeling head if not installed on a system that allows for vertical and horizontal adjustment.
- Allows for vertical and horizontal adjustment in the setup of the labeling head operation.

SET-UP AND ADJUSTMENTS:

- Rotate leveling pads to appropriate position. Secure locknut when proper height is achieved.
- Using ratchet handle, adjust labeling head vertical and horizontal position.

MAINTENANCE:

- Clean wipe down rails with clean cloth.

ITEM	QTY	PART NO.	DESCRIPTION	PARENT ITEM
1	4	791449-000	CASTERS, SWIVEL 3-1/2"	22601F-007
2	4	792065-000	CAP INSERT FOR 4X4 TUBE (1/4WALL)	22601F-007
3	4	A24366-000	MODIFIED LEVELING MOUNT	22601F-007
4	1	D21104-033	ML BASE	22601F-007

NOT SHOWN
C21415-002 - WRAP SUPPORT RISER 60"

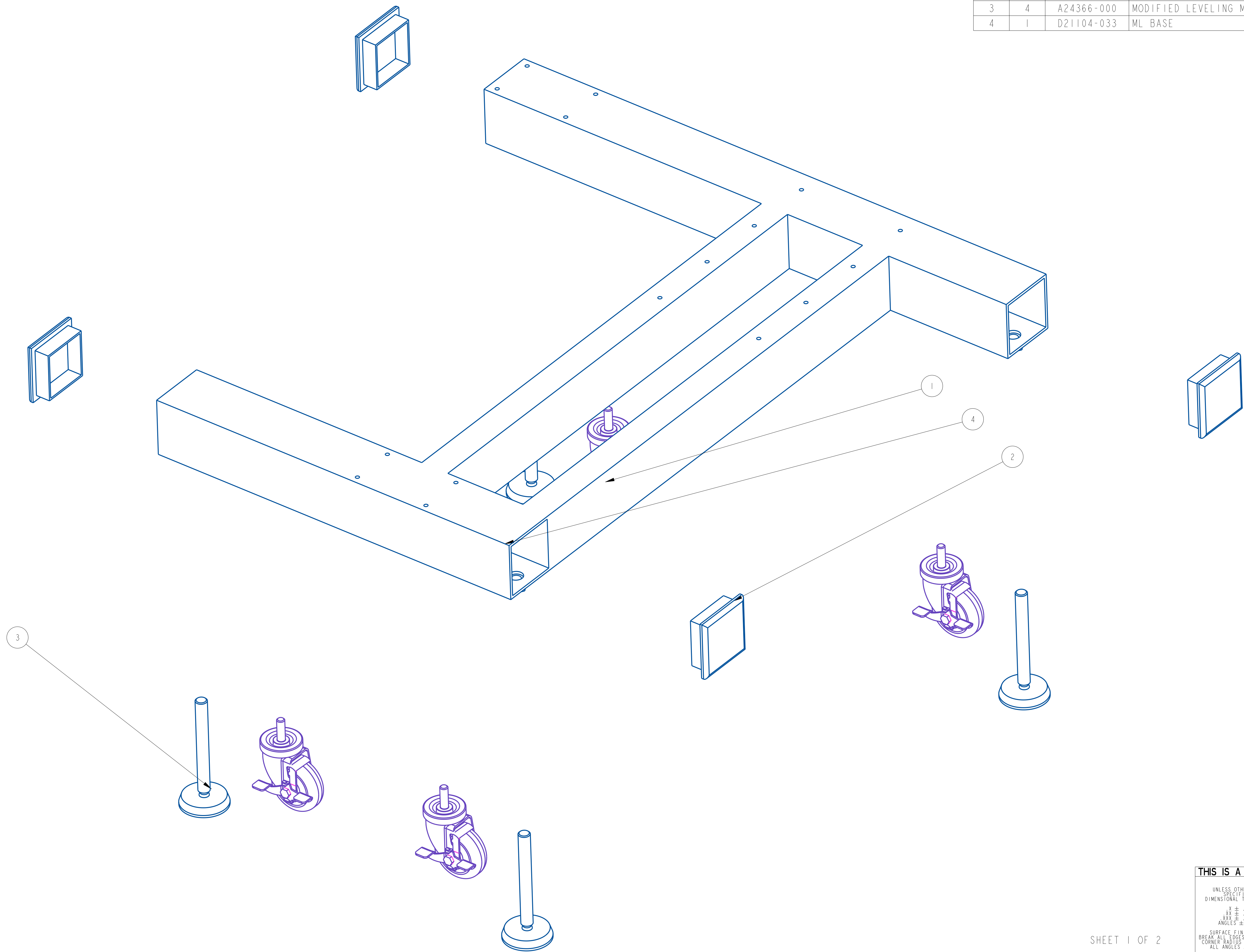

REV	DATE	DESCRIPTION	BY
A	Feb-12-26	NEW DRAWING	TAZ

THIS IS A PRO-ENGINEER DOCUMENT AND MAY NOT BE MODIFIED MANUALLY

QUADREL LABELING SYSTEMS
7670 JENTHER DRIVE
MENTOR, OHIO 44060
(440) 602-4700

SCALE: 11/32
DATE: Feb-12-26
DRW BY: TAZ
CHK BY:
APPR BY:

LH ML125 FRAME ASSEMBLY

MAT'L	22601F-007	22601F-007
-------	------------	------------

UNLESS OTHERWISE SPECIFIED
DIMENSIONAL TOLERANCE
X ± .1
XX ± .01
XXX ± .005
ANGLES ± .30°
SURFACE FINISH 125
BREAK ALL EDGES .005/0.15
CORNER RADIUS .010/0.30
ALL ANGLES ARE 90°

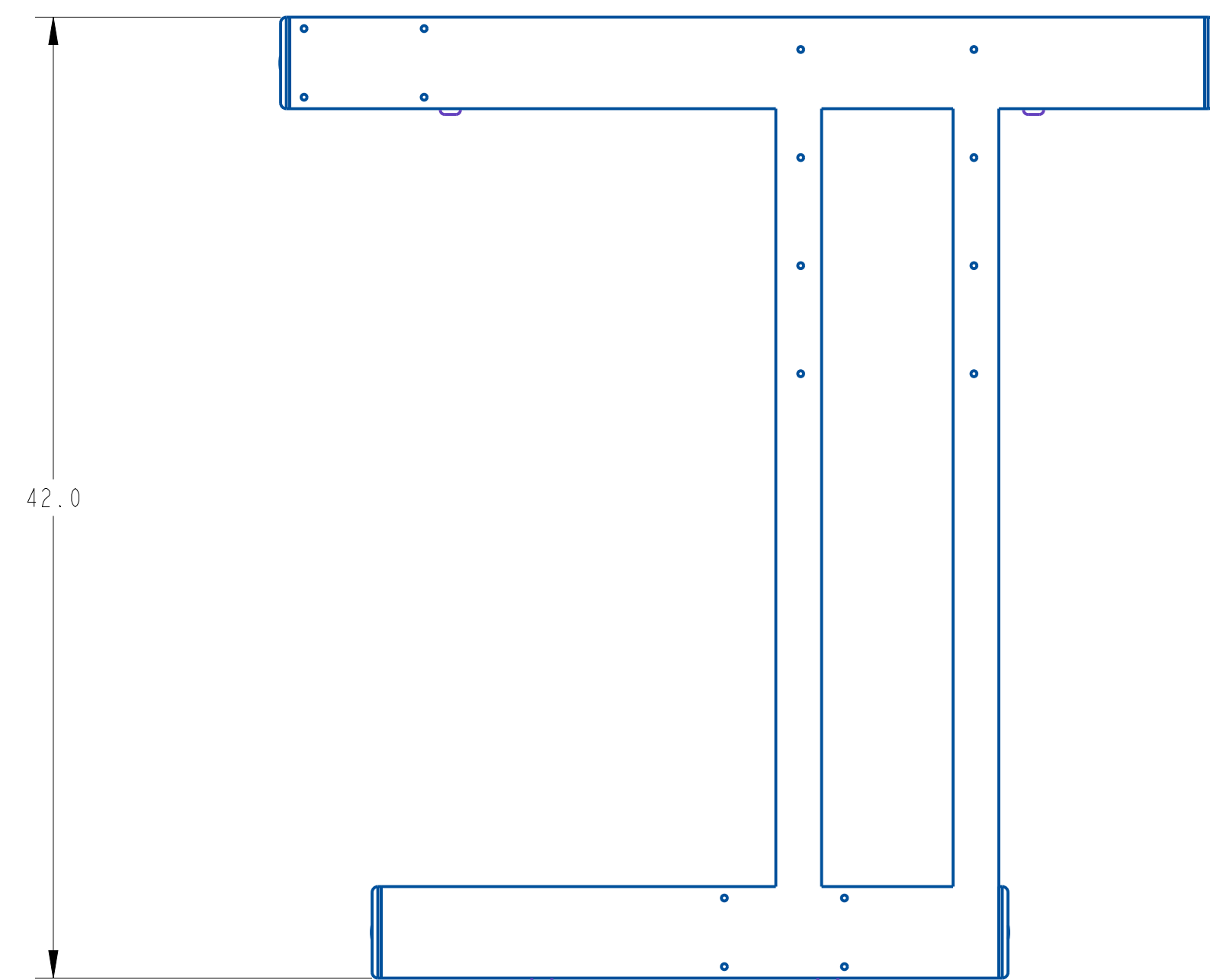
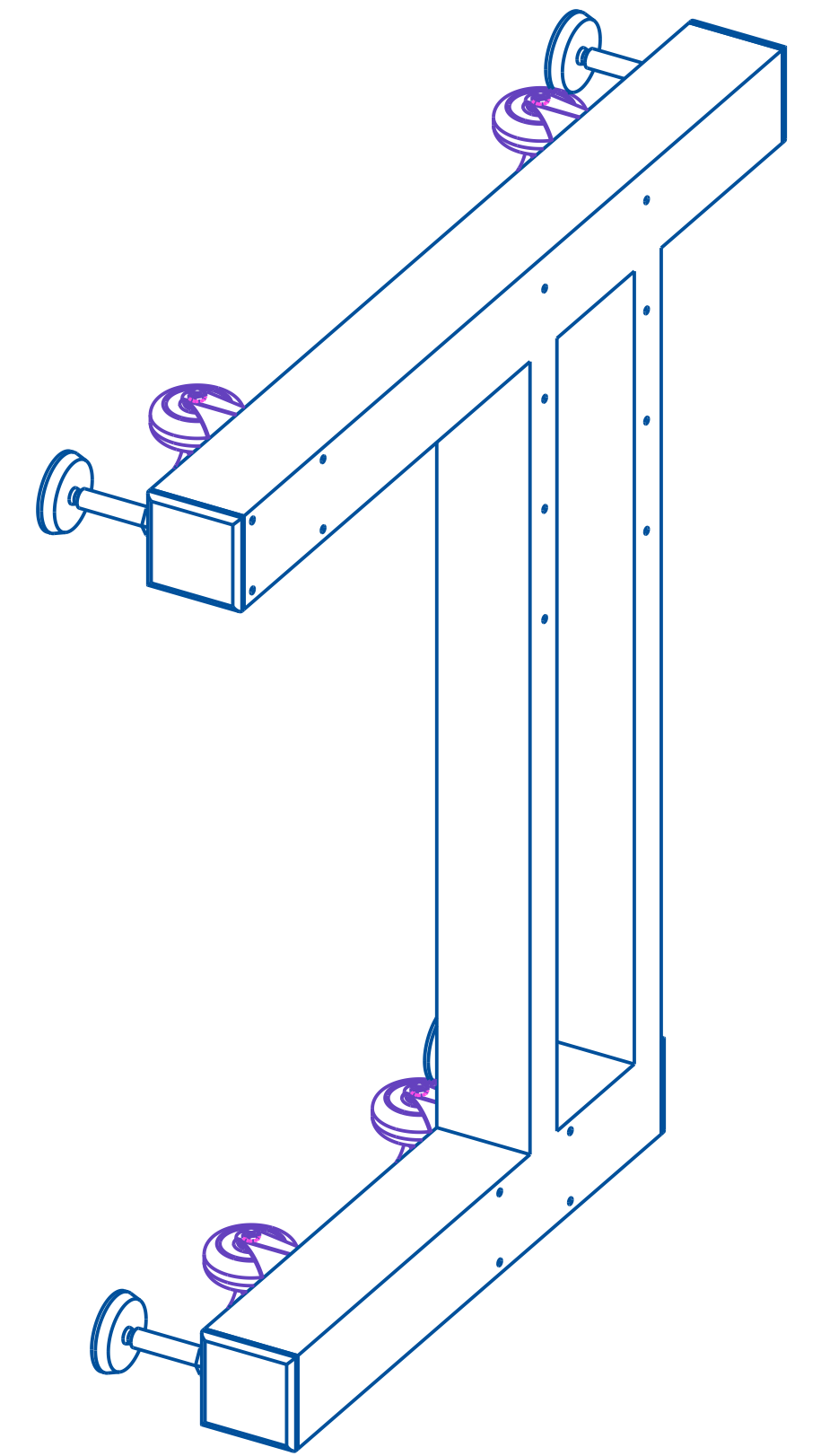
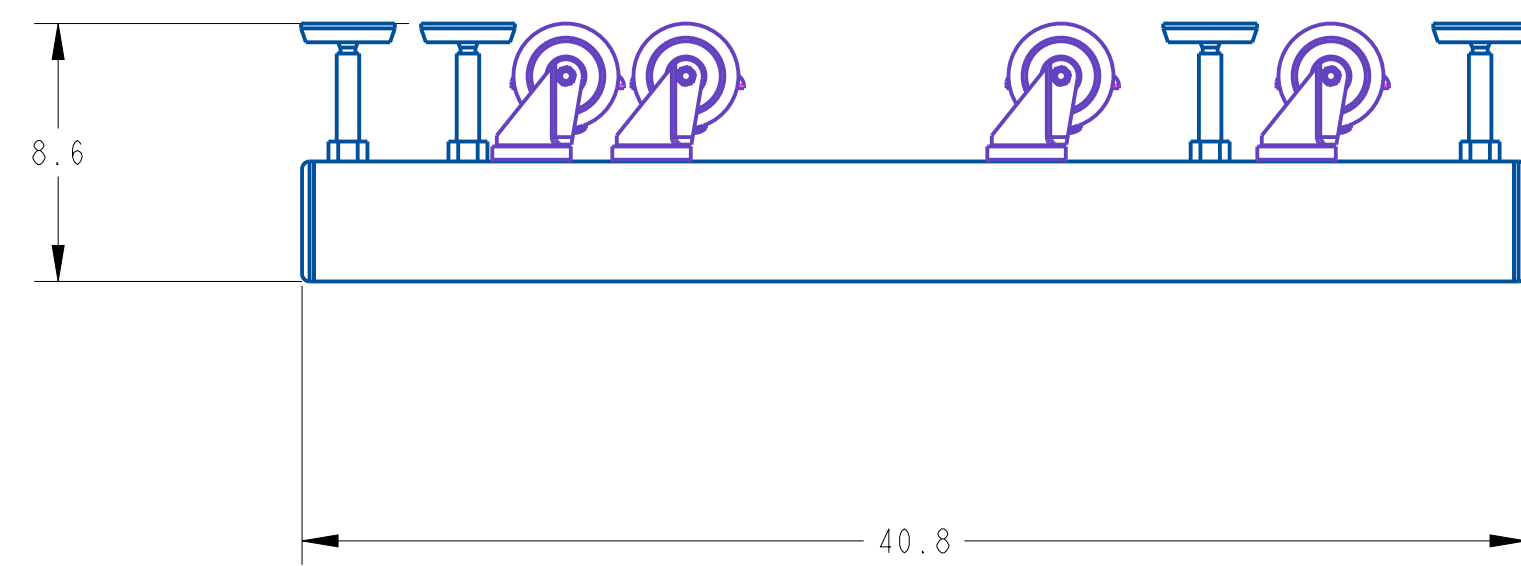

REV	DATE	DESCRIPTION	BY
A	Feb-12-26	NEW DRAWING	TAZ

THIS IS A PRO-ENGINEER DOCUMENT AND MAY NOT BE MODIFIED MANUALLY

QUADREL LABELING SYSTEMS
 7670 JENTHER DRIVE
 MENTOR, OHIO 44060
 (440) 602-4700

SCALE: 5/32
 DATE: Feb-12-26
 DRW BY: TAZ
 CHK BY:
 APPR BY:

LH ML125 FRAME ASSEMBLY
 MAT'L 22601F-007 22601F-007

UNLESS OTHERWISE SPECIFIED
 DIMENSIONAL TOLERANCE
 X ± .1
 XX ± .01
 XXX ± .005
 ANGLES ± .30°
 SURFACE FINISH 125
 BREAK ALL EDGES .005/ .015
 CORNER RADIUS .010/ .030
 ALL ANGLES ARE 90°

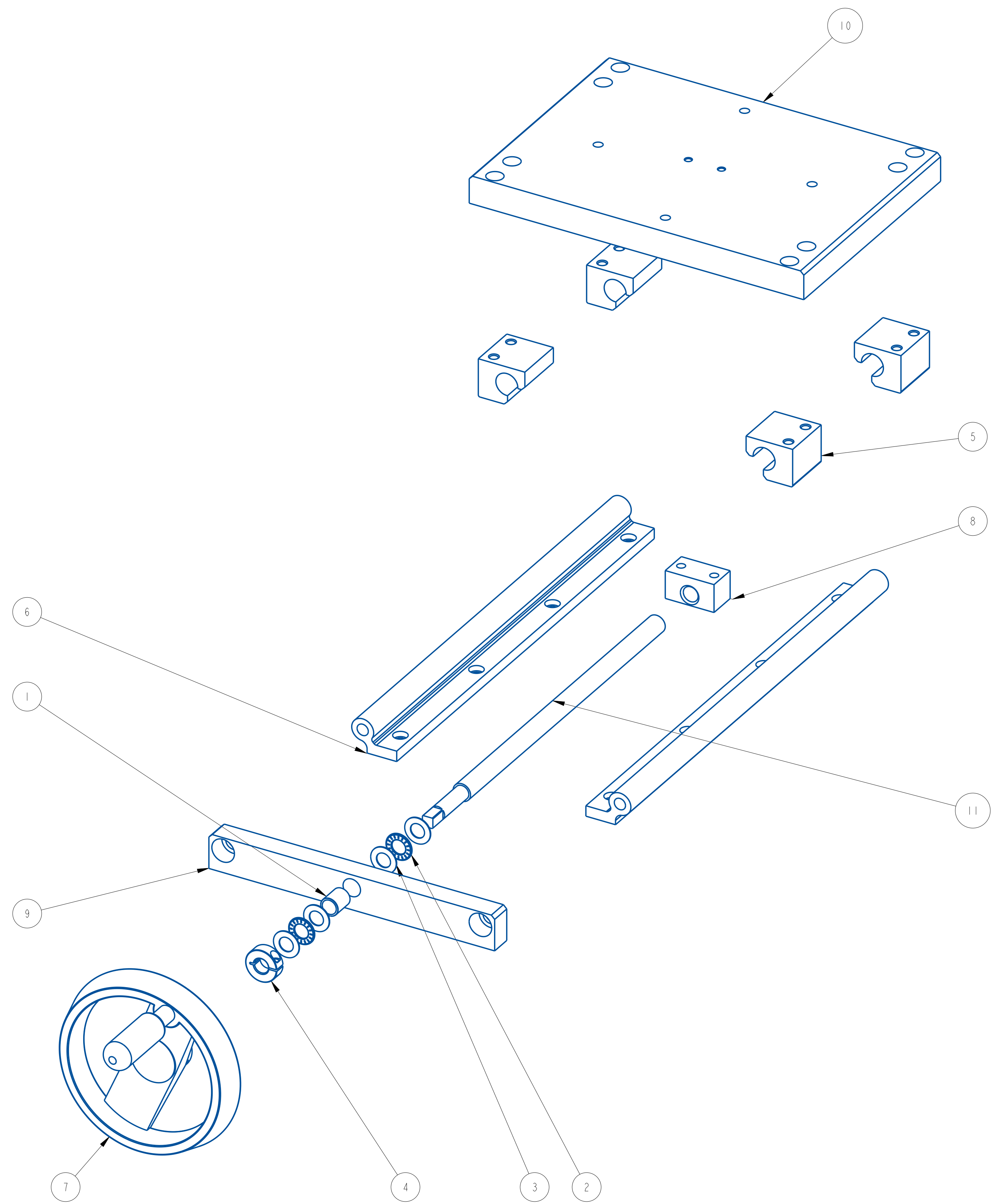

ITEM	QTY	PART NO.	DESCRIPTION	PARENT ITEM
1	1	141177-000	SLEEVE BEARING, 5/8OD. x 1/2ID. x 3/4LNG	84272HA-000
2	2	181079-000	BEARING, NEEDLE ROLLER	84272HA-000
3	4	181080-000	BEARING, THRUST WASHER	84272HA-000
4	1	361169-000	COLLAR, 1/2 IN. ID ONE-PIECE CLAMP	84272HA-000
5	4	792248-001	PILLOW BLOCK	84272HA-000
6	2	792276-000	DRYLIN RAIL	84272HA-000
7	1	801080-000	6" HANDWHEEL	84272HA-000
8	1	A24077-000	BRONZE NUT, RH	84272HA-000
9	1	B21620-000	BEARING PLATE	84272HA-000
10	1	C20753-501	HORIZONTAL SLED, WIDE VERSION	84272HA-000
11	1	C20801-000	THREADED ROD	84272HA-000

REV	DATE	DESCRIPTION	BY
A	Feb-12-26	NEW DRAWING	TAZ

THIS IS A PRO-ENGINEER DOCUMENT AND MAY NOT BE MODIFIED MANUALLY

UNLESS OTHERWISE SPECIFIED DIMENSIONAL TOLERANCE .X ± .1 .XX ± .01 .XXX ± .005 ANGLES ± 30° SURFACE FINISH 125 BREAK ALL EDGES .005/.015 CORNER RADIUS .010/.030	QUADREL LABELING SYSTEMS 7670 JENTHER DRIVE MENTOR, OHIO 44060 (440) 602-4700	SCALE: 1/2 DATE: Feb-12-26 DRW BY: TAZ APPR BY:	
	IGUS HORIZONTAL SLIDE ASSEMBLY		
	MAT'L	84272HA-000	84272HA-000

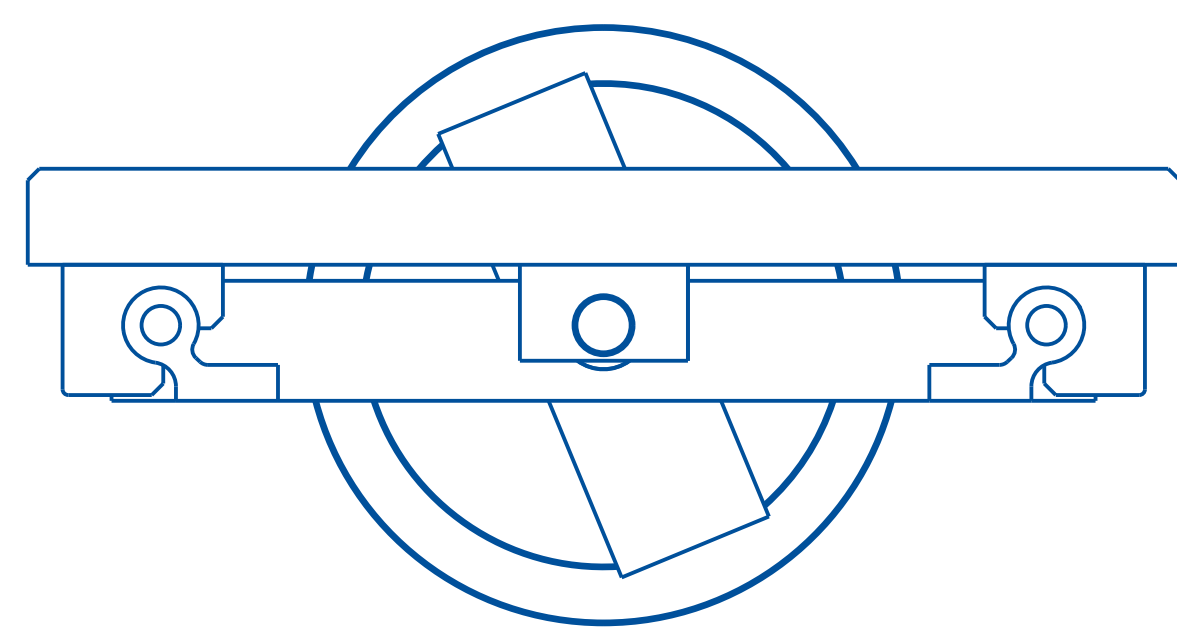
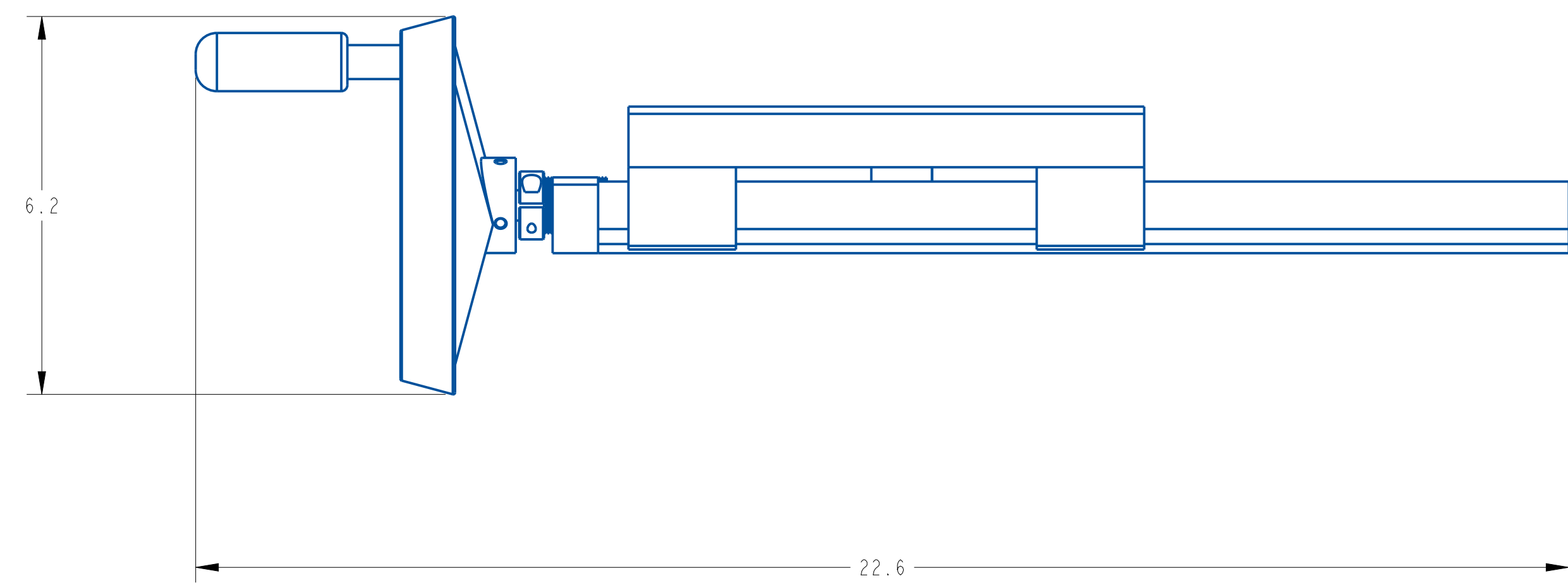
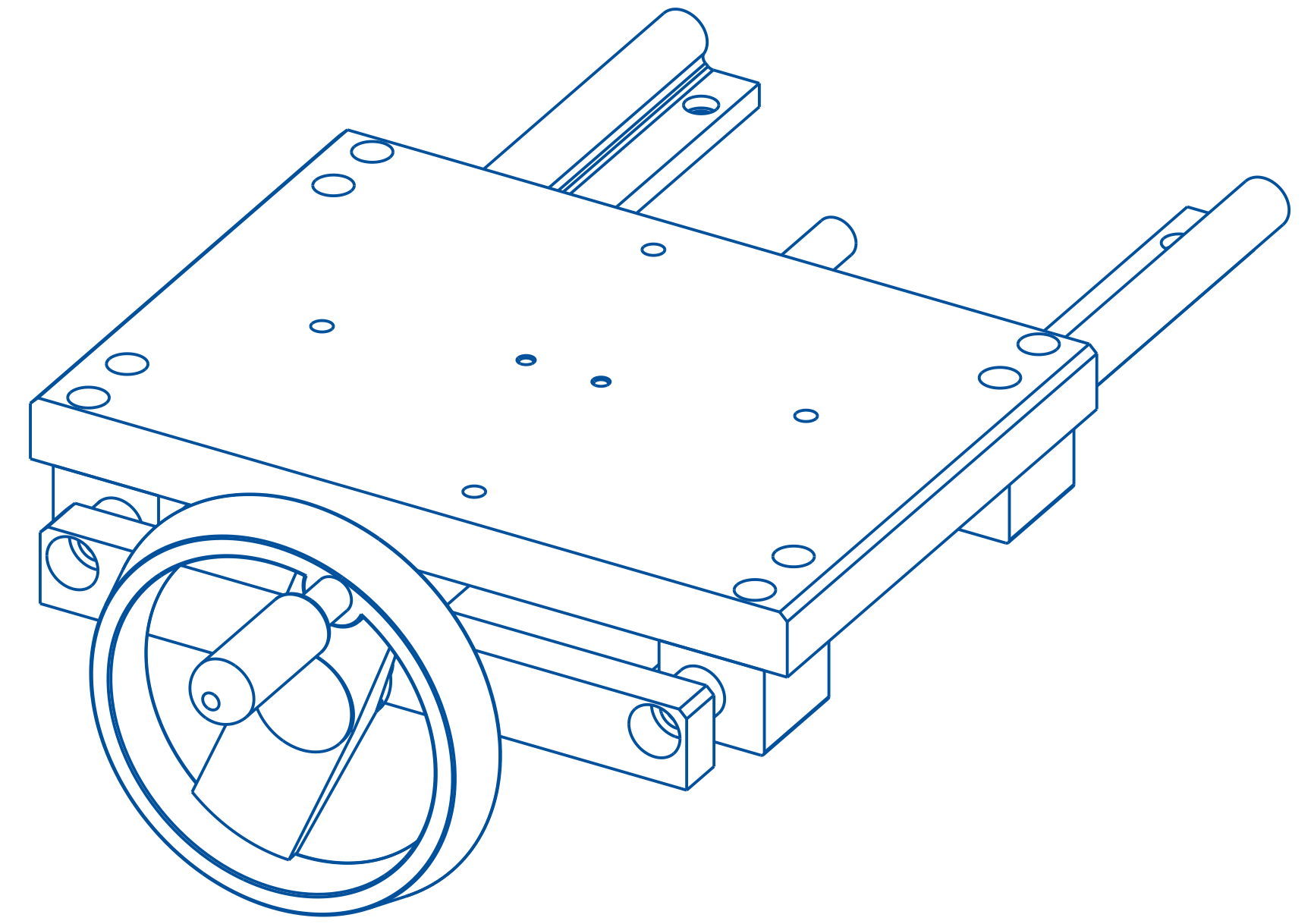
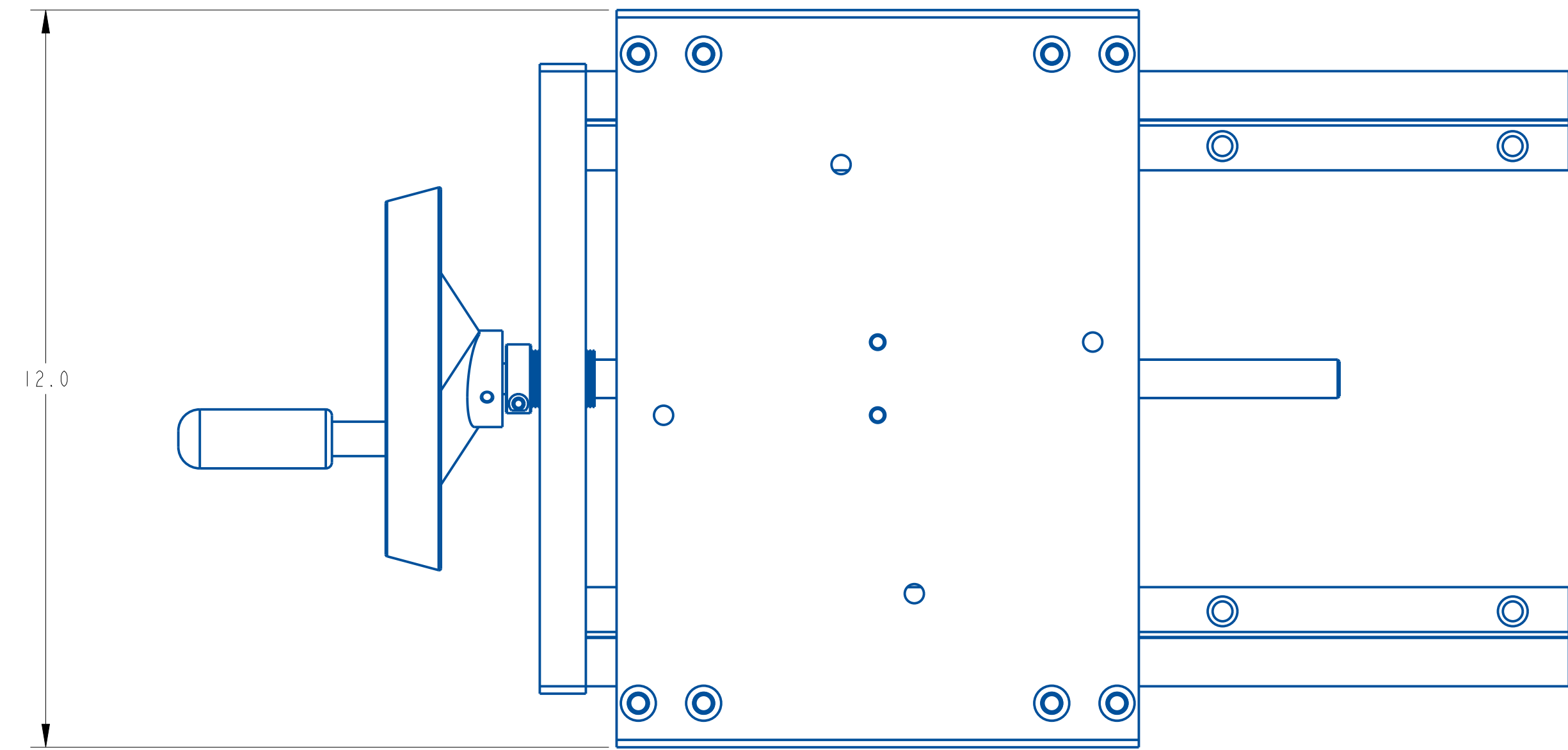

REV	DATE	DESCRIPTION	BY
A	Feb-12-26	NEW DRAWING	TAZ

THIS IS A PRO-ENGINEER DOCUMENT AND MAY NOT BE MODIFIED MANUALLY

UNLESS OTHERWISE SPECIFIED
DIMENSIONAL TOLERANCE

X ± .1
XX ± .01
XXX ± .005
ANGLES ± .30°

SURFACE FINISH 125
BREAK ALL EDGES .005/ .015
CORNER RADIUS .010/ .030
ALL ANGLES ARE 90°

QUADREL LABELING SYSTEMS
7670 JENTHER DRIVE
MENTOR, OHIO 44060
(440) 602-4700

SCALE: 1/2
DATE: Feb-12-26
DRW BY: TAZ
CHK BY:
APPR BY:

IGUS HORIZONTAL SLIDE ASSEMBLY

MAT'L 84272HA-000 84272HA-000

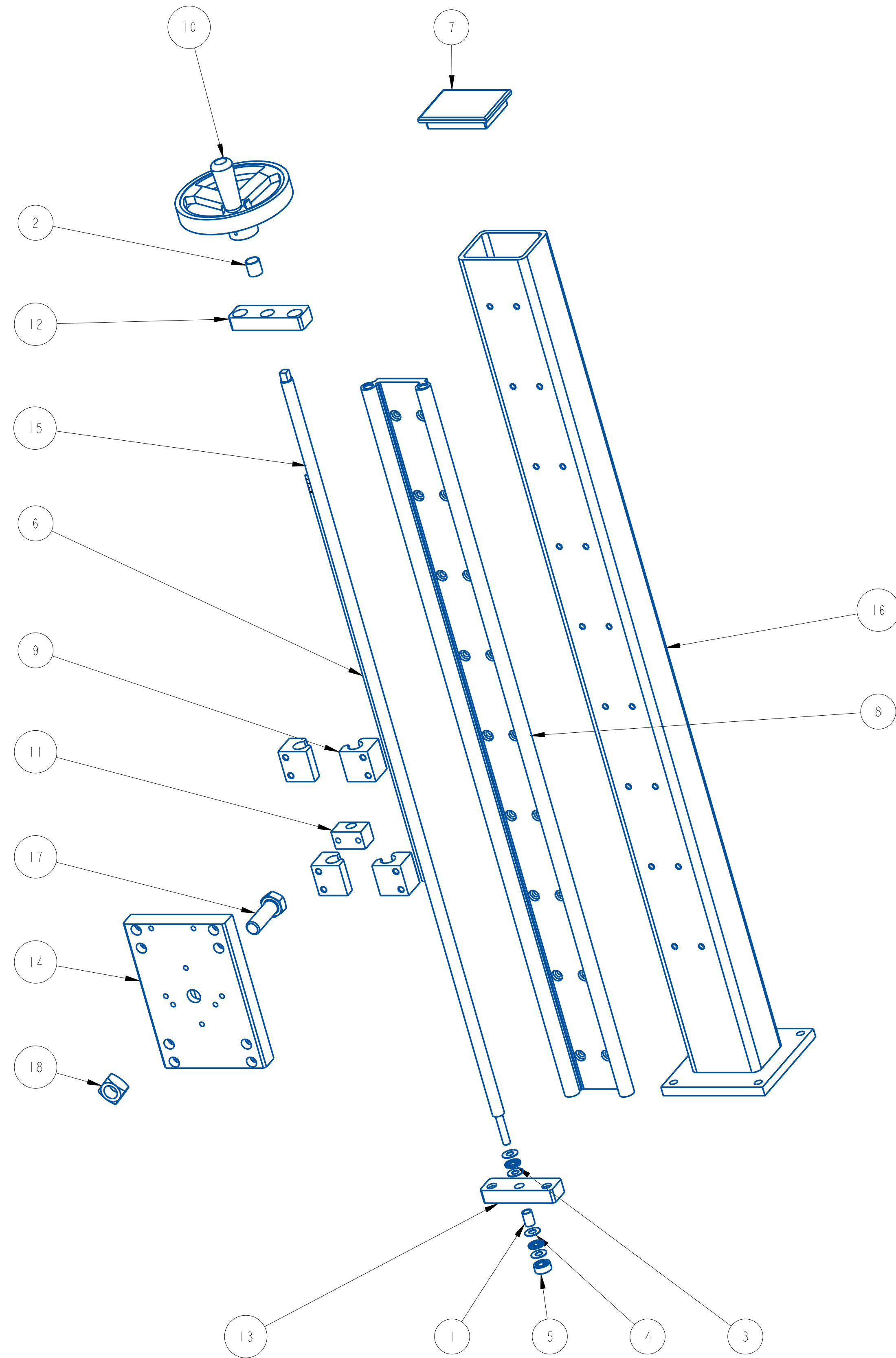

ITEM	QTY	PART NO.	DESCRIPTION	PARENT ITEM
1	1	141172-000	SLEEVE BEARING, 1/2OD. x 3/8ID. x 3/4LNG	82713V-000
2	1	141173-000	SLEEVE BEARING, 23/32OD. x 5/8ID. x 3/4LNG	82713V-000
3	2	181108-000	BEARING, NEEDLE ROLLER	82713V-000
4	4	181111-000	THRUST WASHER	82713V-000
5	1	362186-000	COLLAR, 3/8 IN. ID ONE-PIECE CLAMP	82713V-000
6	1	791914-001	MYLAR SCALE, QUADREL LOGO	82713V-000
7	1	792245-000	CAP INSERT FOR 3 X 4 TUBE	82713V-000
8	1	792247-000	DRYLIN RAIL	82713V-000
9	4	792248-001	PILLOW BLOCK	82713V-000
10	1	801080-000	HANDLE WHEEL, MODIFIED	82713V-000
11	1	A24077-000	BRONZE NUT, RH	82713V-000
12	1	B21345-000	TOP BEARING PLATE	82713V-000
13	1	B21346-000	BOTTOM BEARING PLATE	82713V-000
14	1	C20626-000	STAND SLED	82713V-000
15	1	C20835-000	THREADED ROD, SQUARE END	82713V-000
16	1	D21048-102	WELDMENT, VERTICAL MEMBER	82713V-000
17	1	HCS281		82713V-000
18	1	SON022		82713V-000

REV	DATE	DESCRIPTION	BY
A	12-21-18	NEW DRAWING	ATT

THIS IS A PRO-ENGINEER DOCUMENT AND MAY NOT BE MODIFIED MANUALLY

UNLESS OTHERWISE SPECIFIED DIMENSIONAL TOLERANCE .X ± .1 .XX ± .01 .XXX ± .005 ANGLES ± 30°	QUADREL LABELING SYSTEMS 7670 JENTHER DRIVE MENTOR, OHIO 44060 (440) 602-4700	SCALE: 1/4 DATE: 12-21-18 DRW BY: ATT CHK BY: &CREO_CHK APPR BY:
VERTICAL STAND W/ IGUS SLIDE		
MAT'L	82713V-000	82713V-000

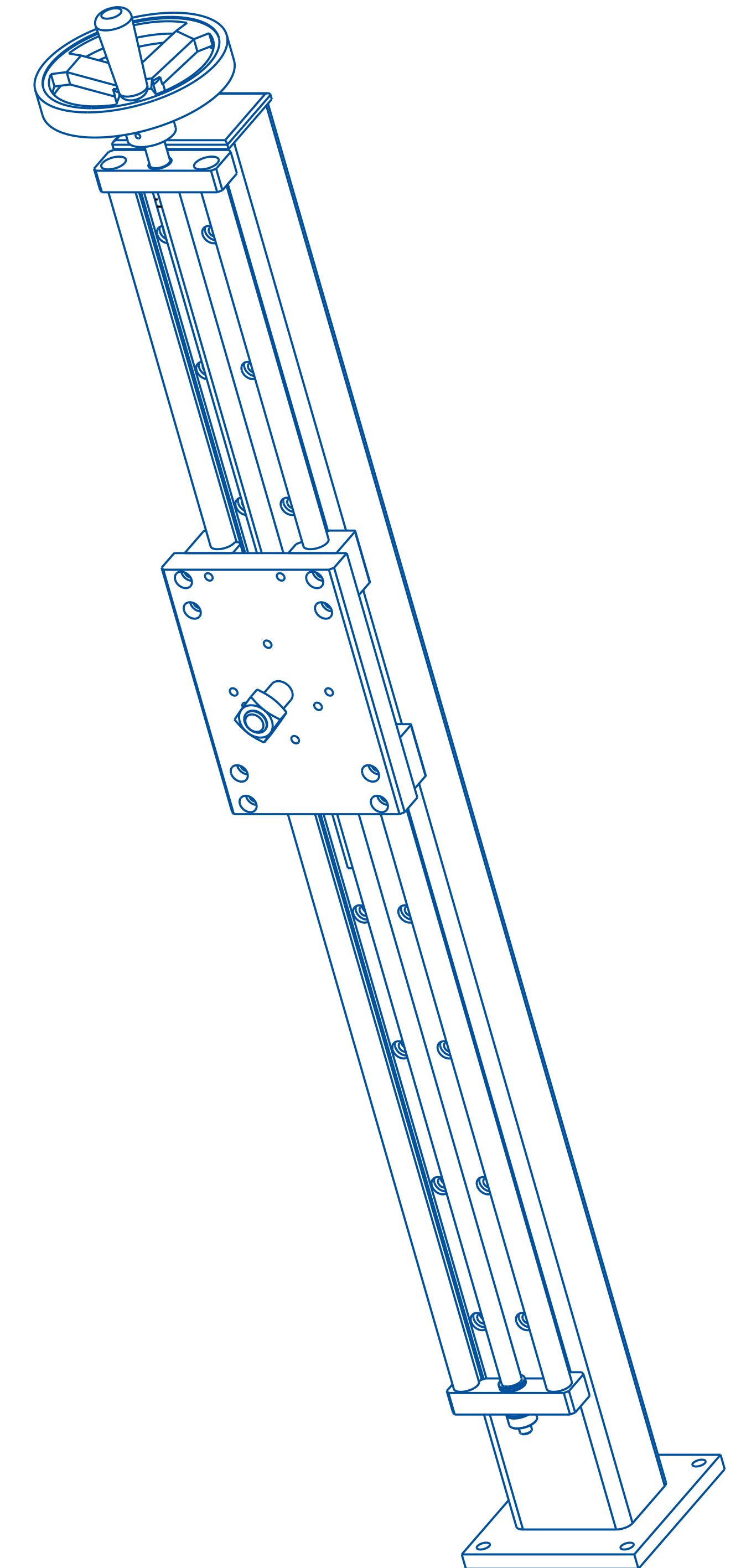
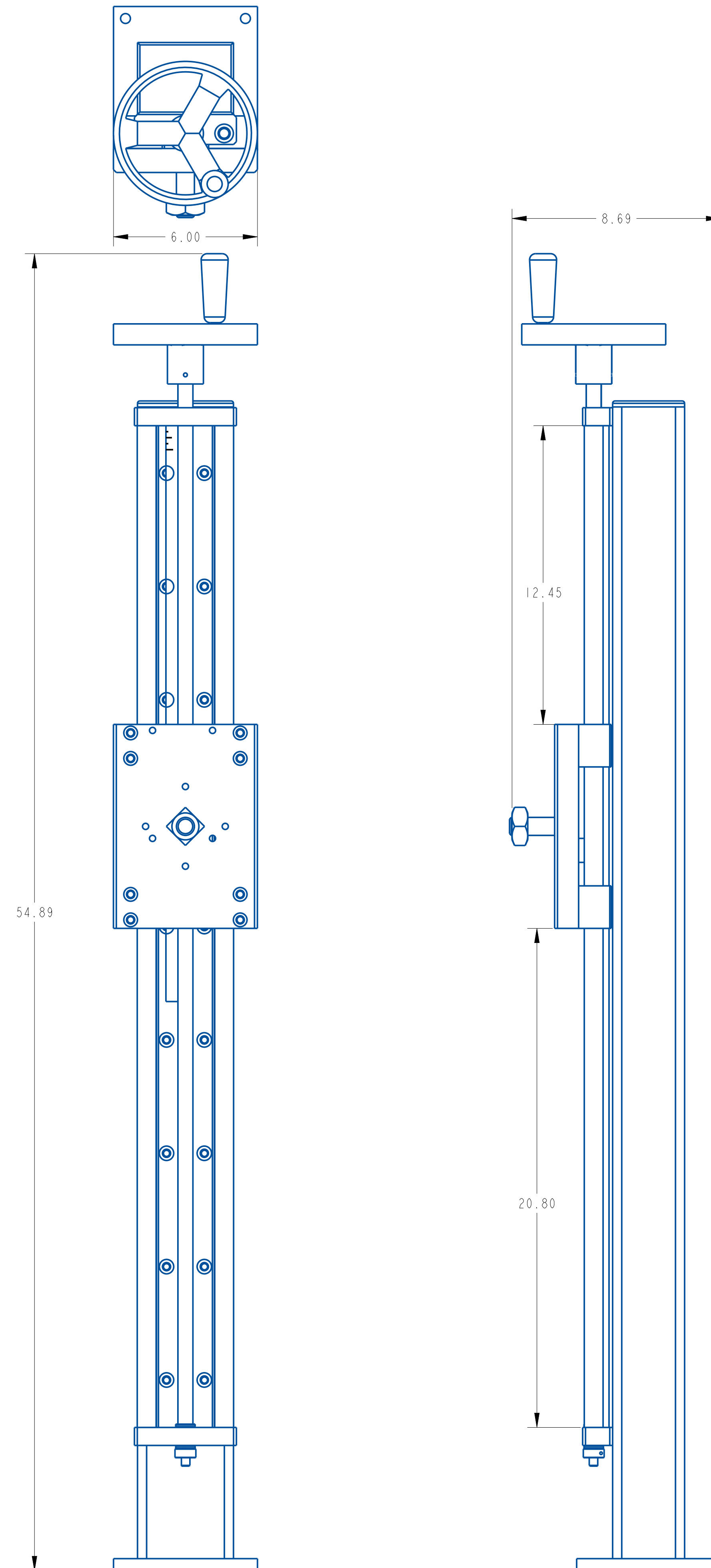

SHEET 2 OF 2

REV	DATE	DESCRIPTION	BY
A	12-21-18	NEW DRAWING	ATT

THIS IS A PRO-ENGINEER DOCUMENT AND MAY NOT BE MODIFIED MANUALLY

UNLESS OTHERWISE SPECIFIED DIMENSIONAL TOLERANCE	.x ± .1 .xx ± .01 .xxx ± .005 ANGLES ± .30°	QUADREL LABELING SYSTEMS 7670 JENTHER DRIVE MENTOR, OHIO 44060 (440) 602-4700	SCALE: 5/16 DATE: 12-21-18 DRW BY: ATT CHK BY: 07/26/2024-SEM APPR BY:
SURFACE FINISH 125 BREAK ALL EDGES .005/0.15 CORNER RADIUS .010/0.30 ALL ANGLES ARE 90°		VERTICAL STAND W/ IGUS SLIDE	MAT'L 82713V-000

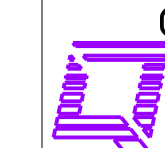

MAT'L

82713V-000

82713V-000

ITEM	QTY	PART NO.	DESCRIPTION	PARENT ITEM
1	2	801850-000	CLAMPING LEVER	22816-016
2	2	B21190-114	YOKE SIDE PLATE	22816-016
3	1	B21555-300	MTG YOKE BACK PLATE	22816-016

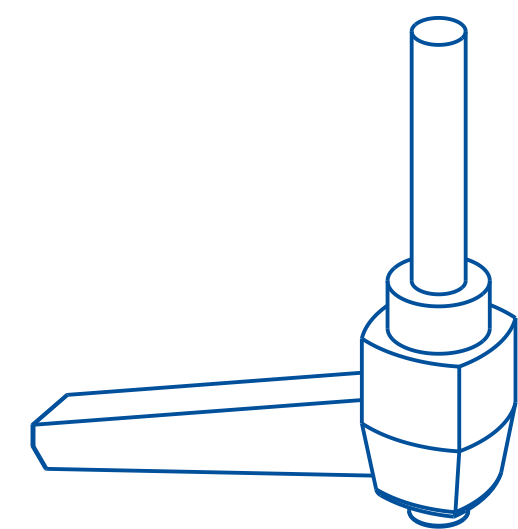
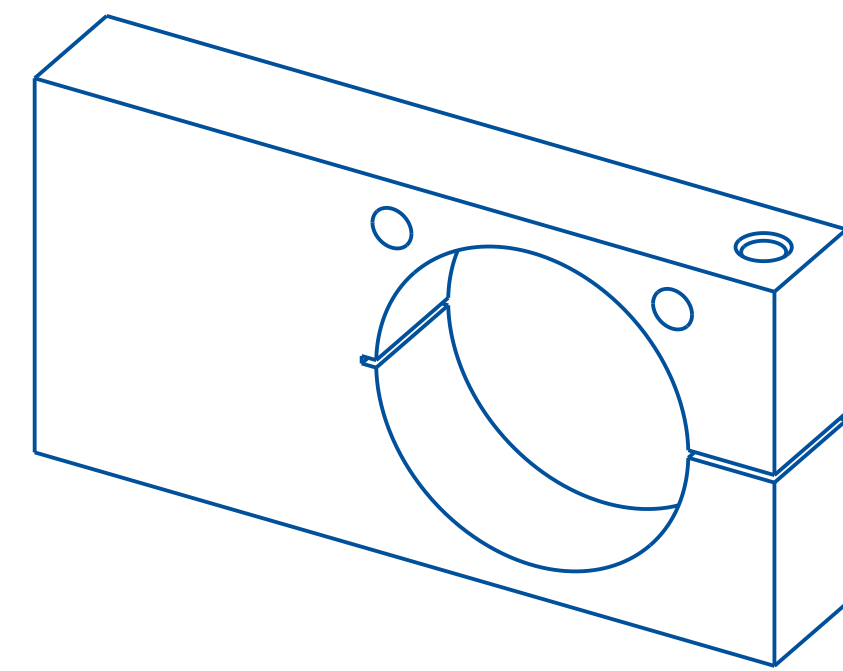
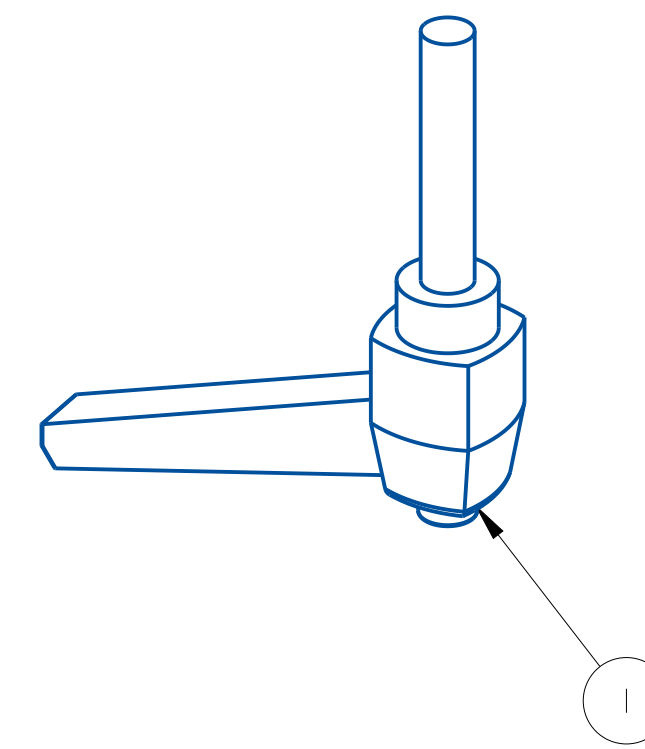
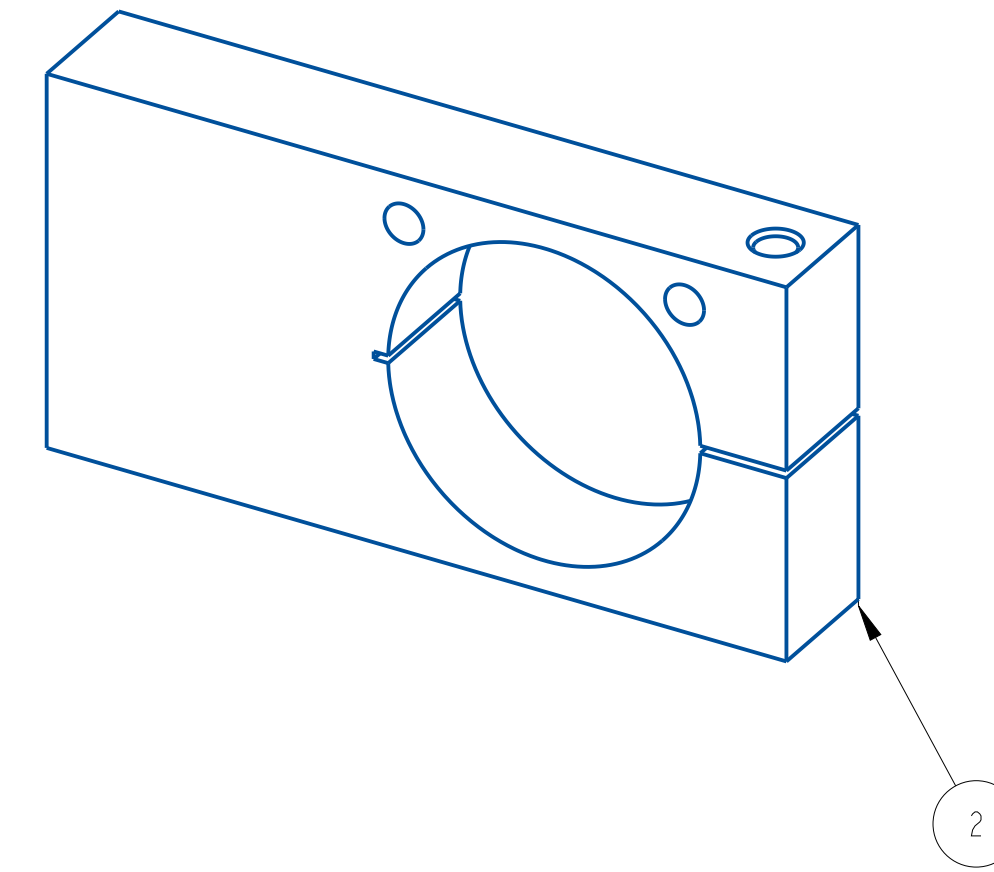
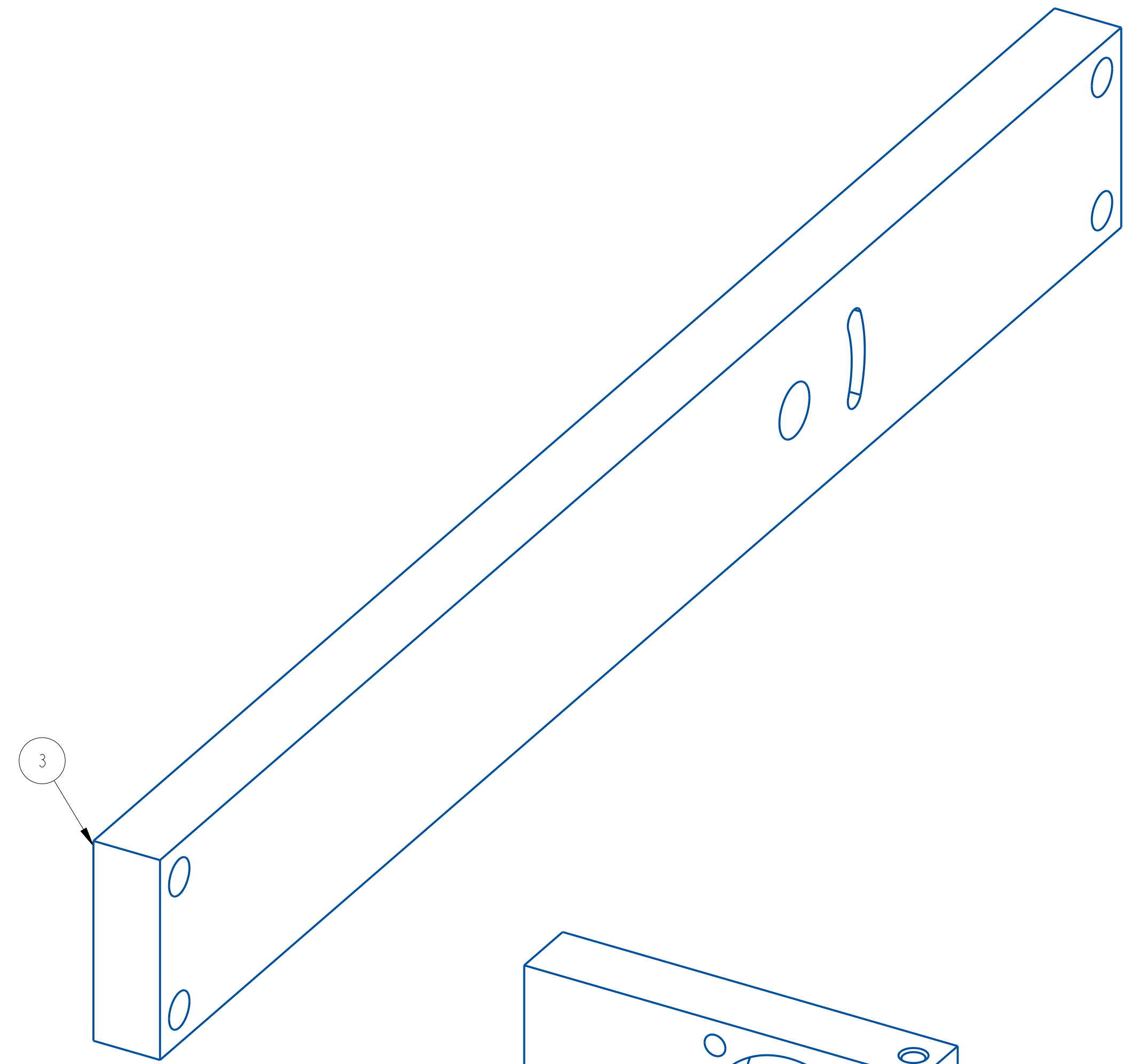

REV	DATE	DESCRIPTION	BY
A	Feb-12-26	NEW DRAWING	TAZ

THIS IS A PRO-ENGINEER DOCUMENT AND MAY NOT BE MODIFIED MANUALLY

UNLESS OTHERWISE SPECIFIED DIMENSIONAL TOLERANCE .X ± .1 .XX ± .01 .XXX ± .005 ANGLES ± .30° SURFACE FINISH 125 BREAK ALL EDGES .005/.015 CORNER RADIUS .010/.030 ALL ANGLES ARE 90°	QUADREL LABELING SYSTEMS 7670 JENTHER DRIVE MENTOR, OHIO 44060 (440) 602-4700		SCALE: 3/4 DATE: Feb-12-26 DRW BY: TAZ CHK BY: APPR BY:
	Q110/Q120/Q125 YOKE ASSEMBLY		
	MAT'L	22816-016	22816-016

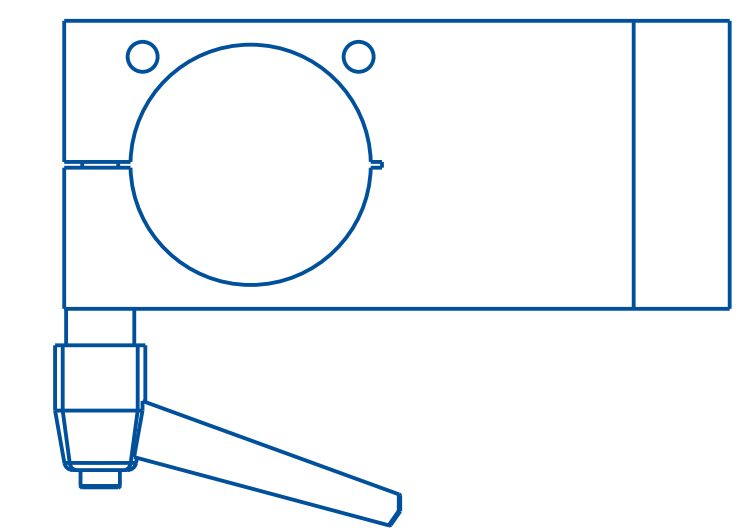
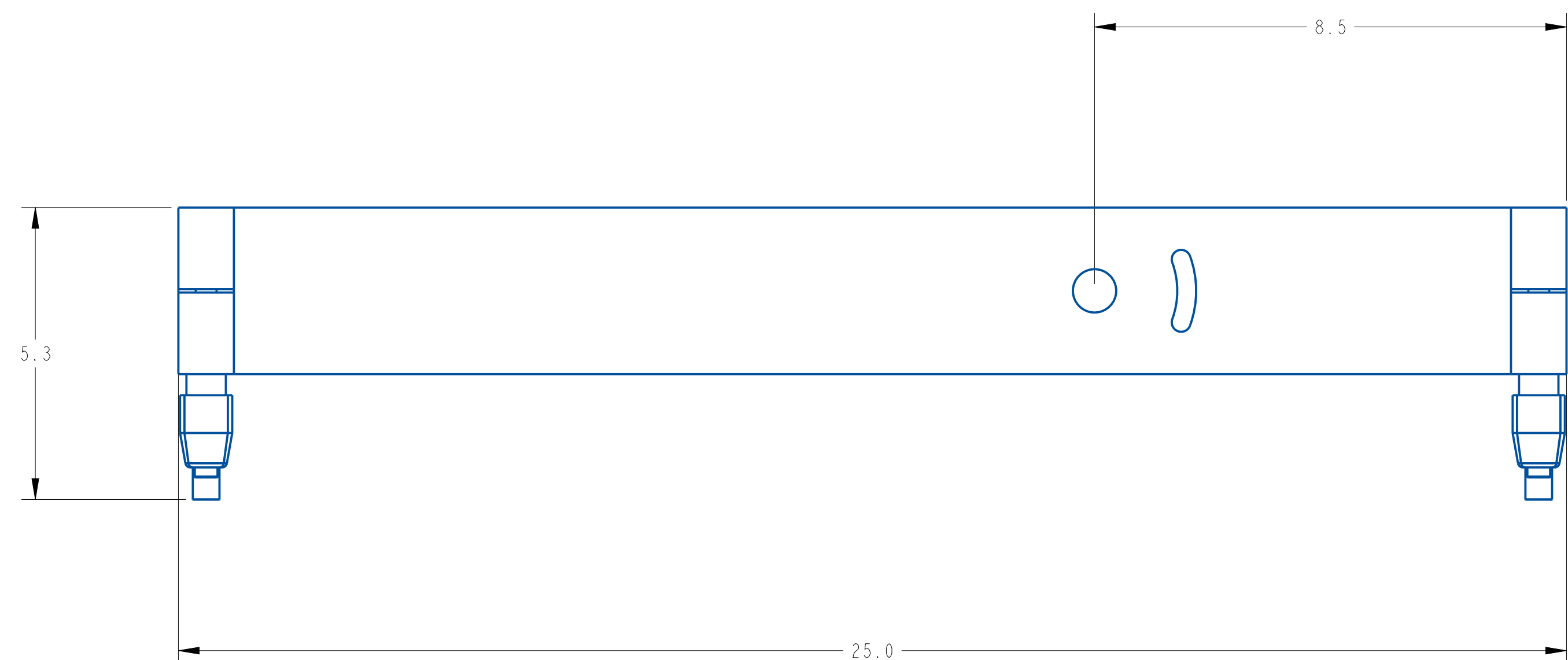
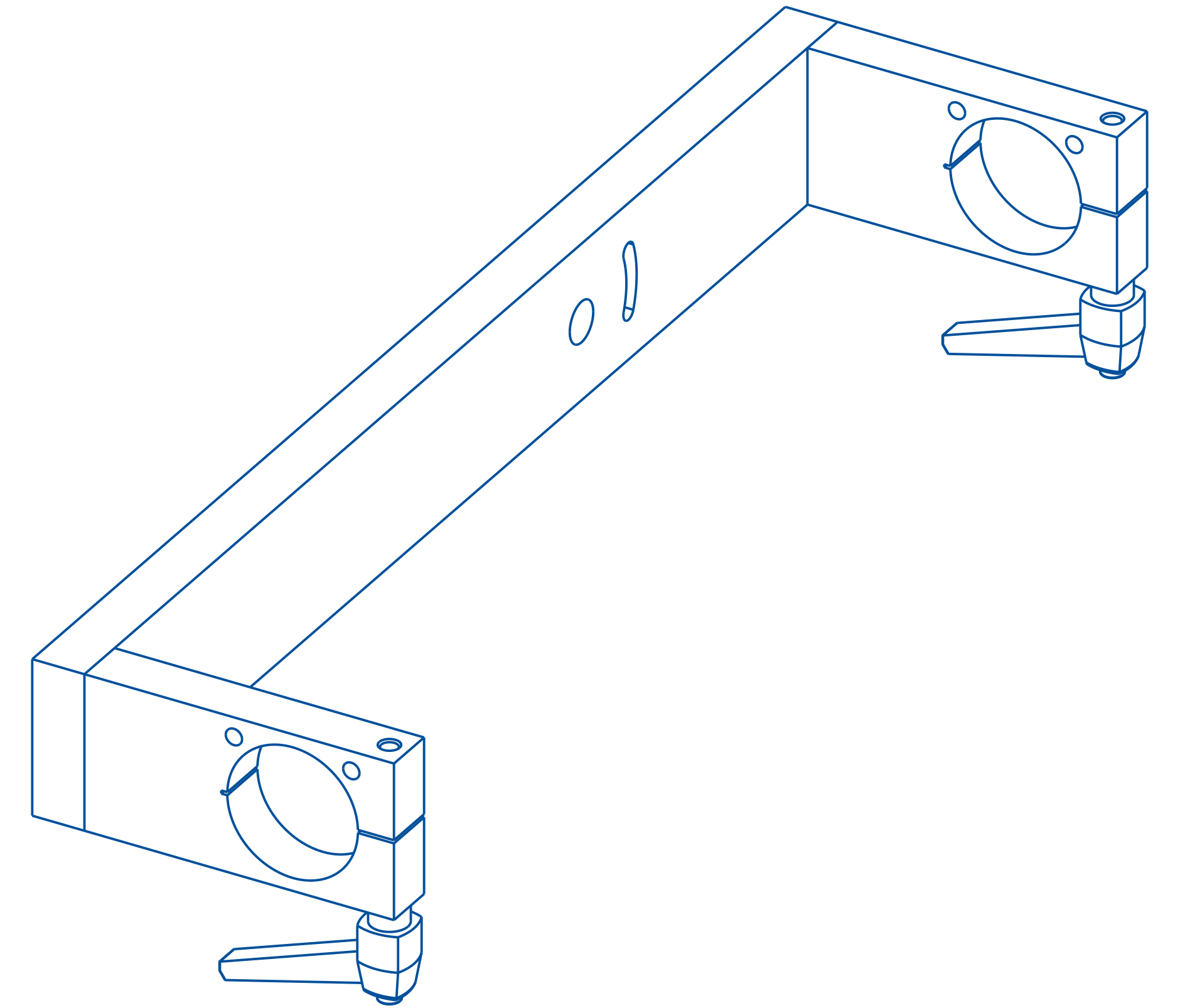
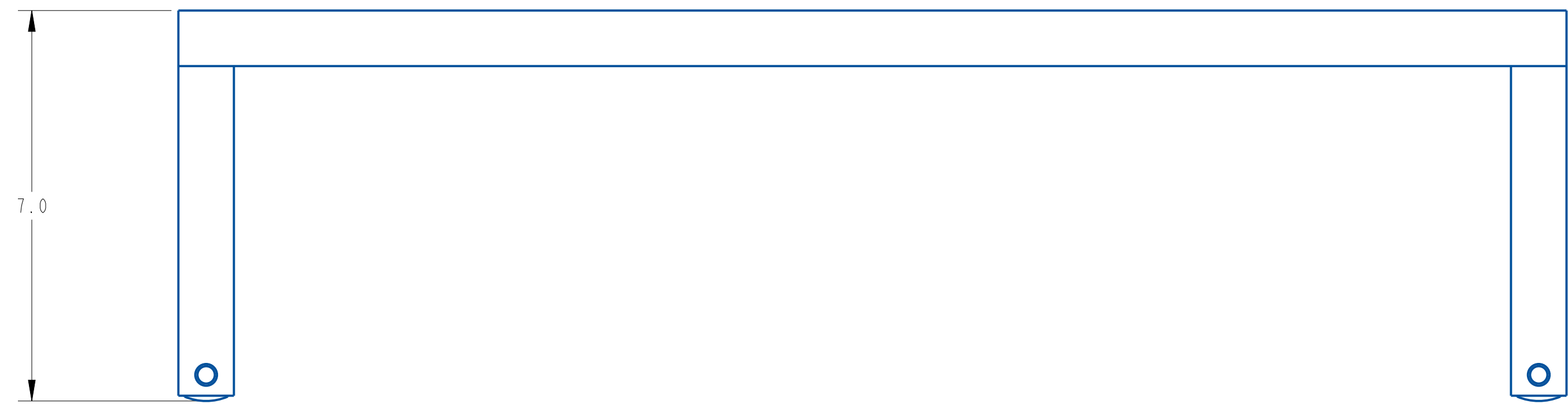

REV	DATE	DESCRIPTION	BY
A	Feb-12-26	NEW DRAWING	TAZ

THIS IS A PRO-ENGINEER DOCUMENT AND MAY NOT BE MODIFIED MANUALLY

QUADREL LABELING SYSTEMS
 7670 JENTHER DRIVE
 MENTOR, OHIO 44060
 (440) 602-4700

SCALE: 1/2
 DATE: Feb-12-26
 DRW BY: TAZ
 CHK BY:
 APPR BY:

Q110/Q120/Q125 YOKE ASSEMBLY
 MAT'L 22816-016 22816-016

UNLESS OTHERWISE SPECIFIED
 DIMENSIONAL TOLERANCE
 .x ± .1
 .xx ± .01
 .xxx ± .005
 ANGLES ± .30°
 SURFACE FINISH 125
 BREAK ALL EDGES .005/.015
 CORNER RADIUS .010/.030
 ALL ANGLES ARE 90°

ITEM	QTY	PART NO.	DESCRIPTION	PARENT ITEM
1	2	793045-000	DIAMOND KNURL KNOB	22892-001
2	2	A26179-120	KNOB STUD	22892-001
3	1	C21348-120	ADJUSTMENT PLATE	22892-001

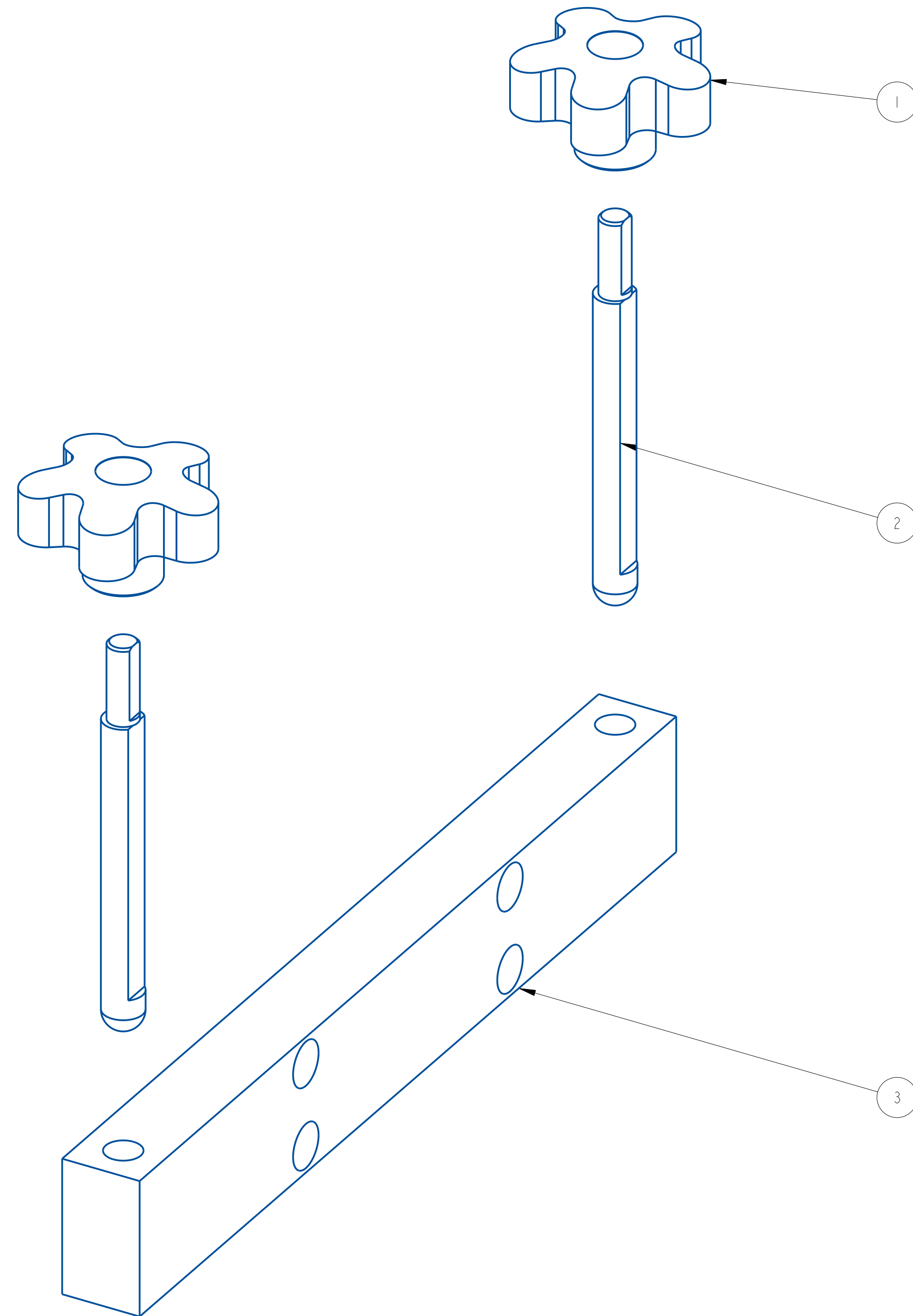

REV	DATE	DESCRIPTION	BY
A	02/12/26	NEW DRAWING	SEM

THIS IS A PRO-ENGINEER DOCUMENT AND MAY NOT BE MODIFIED MANUALLY

UNLESS OTHERWISE SPECIFIED DIMENSIONAL TOLERANCE .X ± .1 .XX ± .01 .XXX ± .005 ANGLES ± 30° SURFACE FINISH 125 BREAK ALL EDGES .005/0.15 CORNER RADIUS .010/0.30 ALL ANGLES ARE 90°	QUADREL LABELING SYSTEMS 7670 JENTHER DRIVE MENTOR, OHIO 44060 (440) 602-4700		SCALE: 1/1 DATE: 02/12/26 DRW BY: SEM CHK BY: 02/12/2026-SEM APPR BY:
	TOP TRAP ADJUSTMENT		
	MAT'L		22892-001

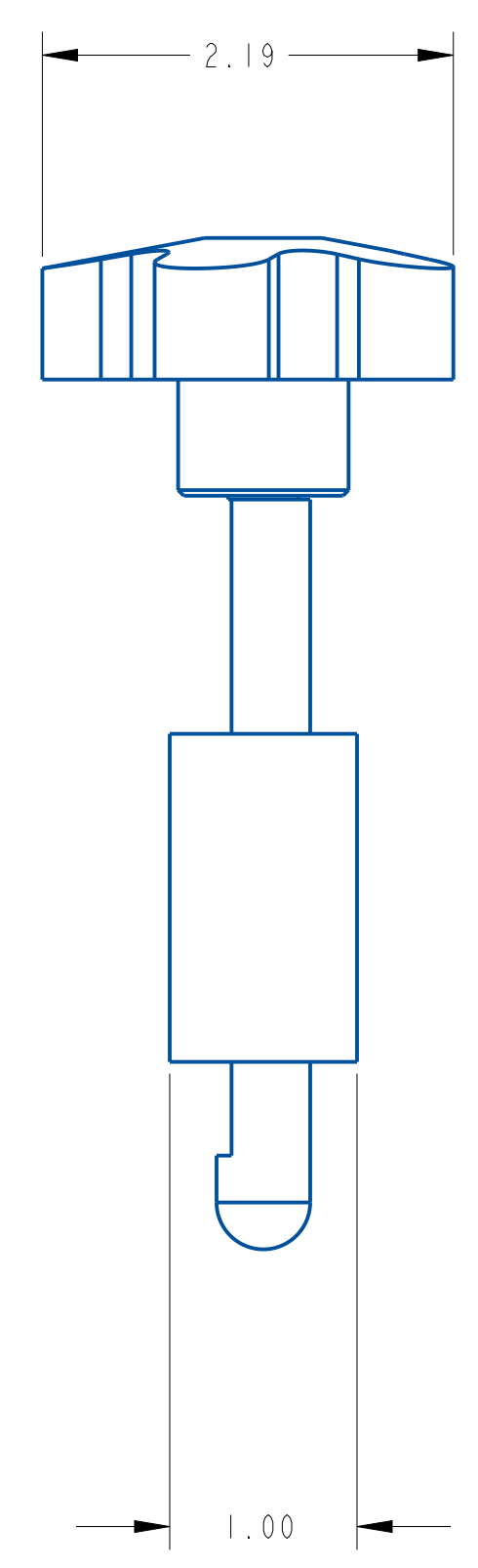
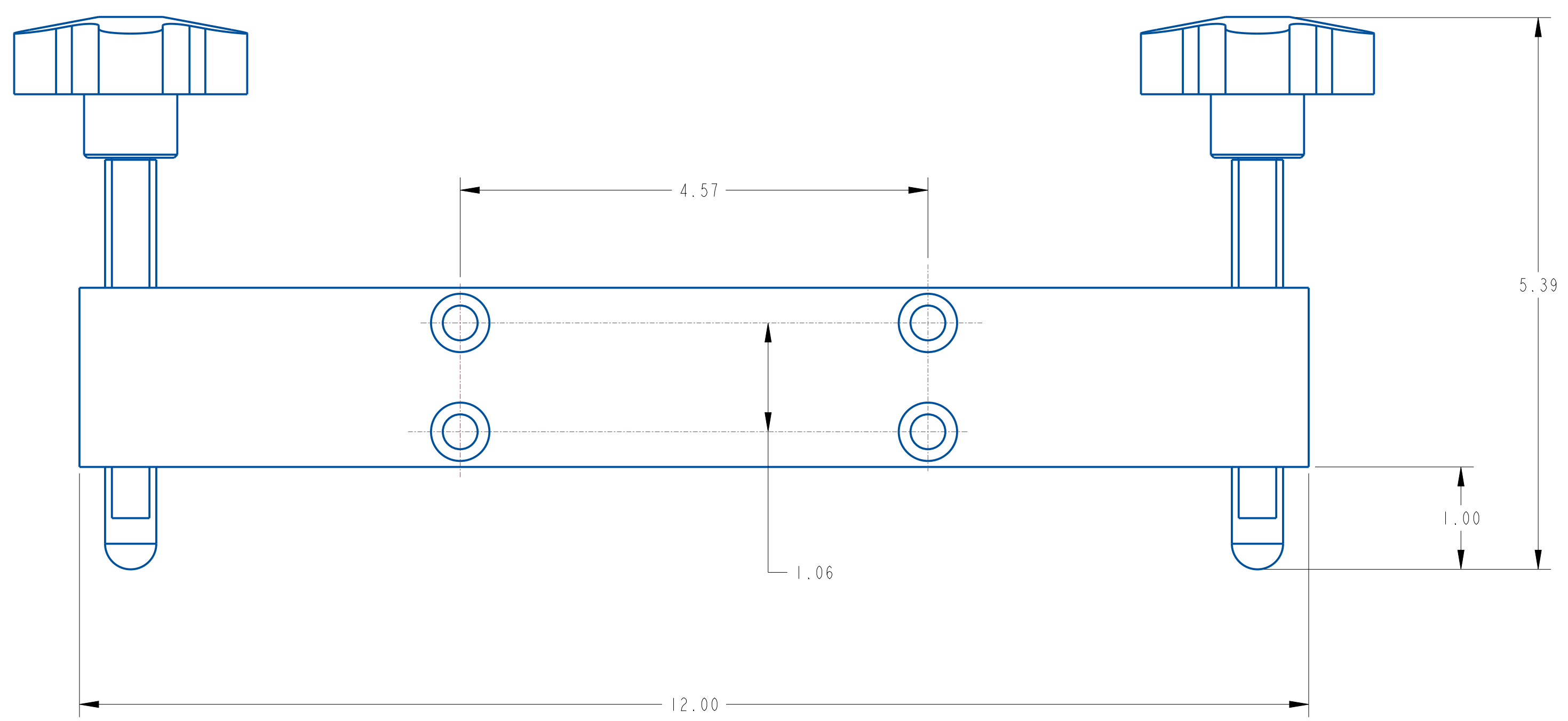
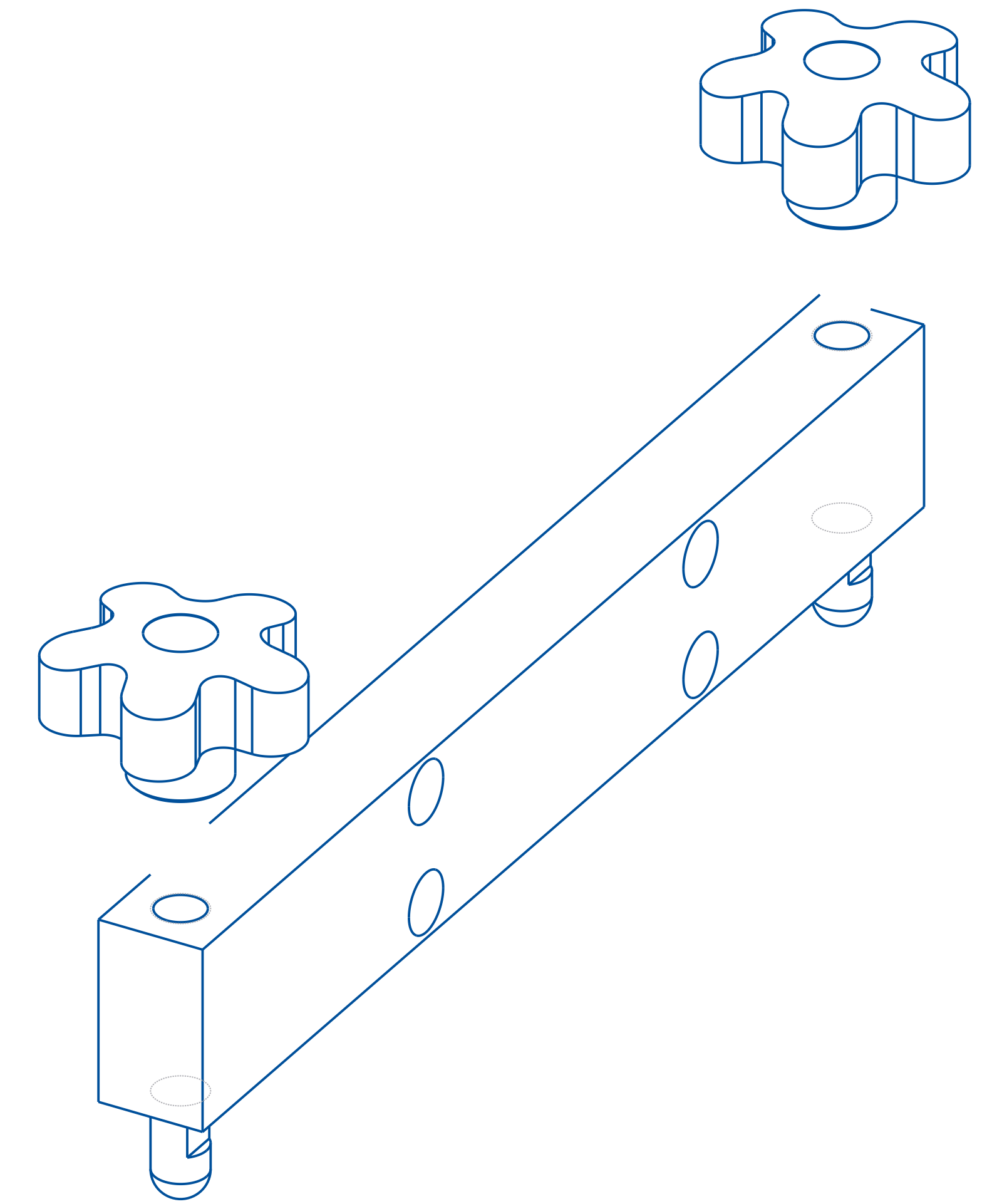
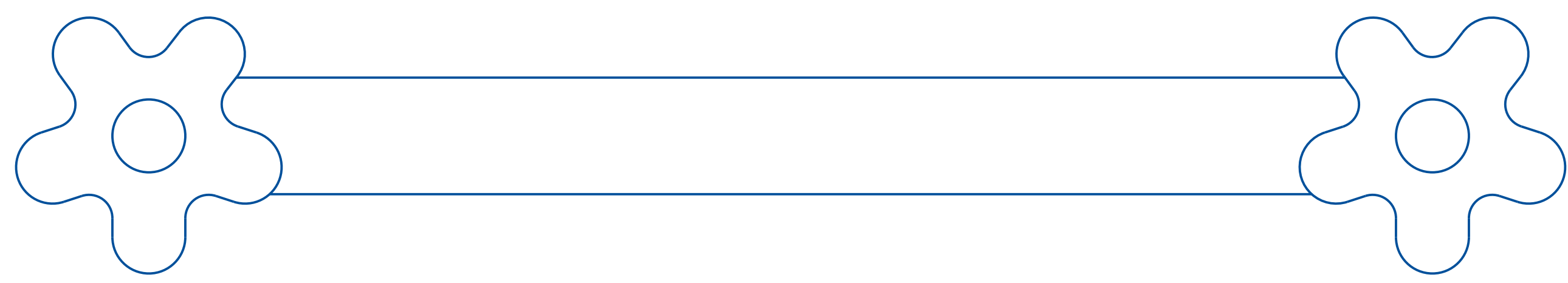

THIS IS A PRO-ENGINEER DOCUMENT AND MAY NOT BE MODIFIED MANUALLY

REV	DATE	DESCRIPTION	BYE
A	09/22/25	NEW DRAWING	SEM

UNLESS OTHERWISE SPECIFIED
 DIMENSIONAL TOLERANCE
 .x ± .1
 .xx ± .01
 .xxx ± .005
 ANGLES ± .30°
 SURFACE FINISH 125
 BREAK ALL EDGES .005/.015
 CORNER RADIUS .010/.030
 ALL ANGLES ARE 90°

QUADREL LABELING SYSTEMS
 7670 JENTHER DRIVE
 MENTOR, OHIO 44060
 (440) 602-4700

SCALE: 1/1
 DATE: 09/22/25
 DRW BY: SEM
 CHK BY: 02/12/2026-SEM
 APPR BY:

TOP TRAP ADJUSTMENT

MAT'L

22892-001

7.5 WRAP STATION ASSEMBLY

7.5.1 GENERAL INFORMATION

The wrap station is generally positioned near the labeler and is made up of a belt/roller assembly activated by a DC motor (with encoder), and AC motor, or servo motor coupled to a gear box and adjusting plate. The wrap station paired with a foam back plate assembly is used for cylindrical products to ensure impression 360 degrees around the container. There are two wrap styles depending on your specific application. A triangle wrap station (pictured on the left) is used primarily in “flag and wrap” applications where the wrap station is positioned after the top hold down. Our direct wrap or rectangle wrap station (pictured on the right) is positioned directly after the peel plate. This wrap station comes with a dc motor with an encoder to ensure absolute synchrony with the labeling head.

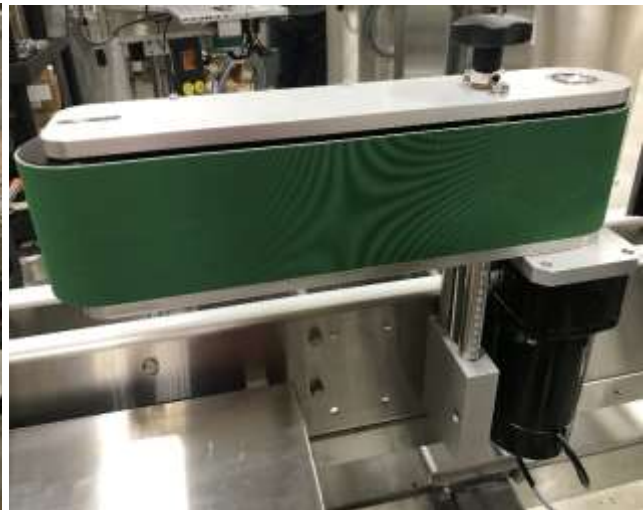
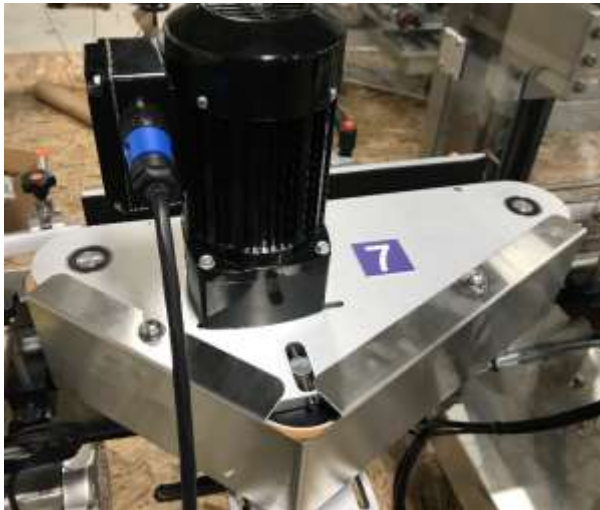

7.5.2 ADJUSTMENTS

Depending on the height of your product and placement of your label you may need to adjust the height of the wrap station. Adjusting the height on your wrap station is very simple. On a triangle wrap station rotate the handwheel counter clockwise or clockwise to raise and lower the wrap station.



On a rectangle wrap station locate the handle on the mount for the wrap station. Loosen the ratchet handle, then simply turn the knob on top of the wrap station clockwise and counter clockwise to raise and lower the wrap station. This is the only adjustment for the rectangle wrap station on this mount.



The triangle wrap station has the ability to travel in and out. This adjustment is used in applications with skinnier products, or a situation where you need to move the wrap out of the way. To achieve this adjustment loosen both ratchet handles and the wrap station. Tighten when in place.



CAUTION

Do not make this adjustment when the wrap station is running.



In more difficult applications such as tapered containers you may need to adjust the tilt of the wrap station to match the products taper (If the taper is too great other methods are used). To adjust the tilt or to square the wrap station to the conveyor or container locate the 4 set screws on the wrap mount loosen the jam nuts and tighten or loosen the set screws to tilt the wrap station as desired.



ASSEMBLY TITLE:**WRAP ASSEMBLY****DRAWING:****GENERAL FUNCTION:**

- The wrap station is used in conjunction with a single labeling head to apply a label around a cylindrical product. The wrap station length will vary with respect to the maximum length of label being applied.

SET UP AND ADJUSTMENTS:

- The wrap station is attached to mounting blocks which clamp to mounting rails affixed to the conveyor side plate. The wrap station can be moved by loosening the locking levers holding the wrap station in place. Position as needed and retighten locking levers.
- Set the speed of the wrap station with the manual speed control mounted in the drive/disconnect enclosure. The maximum rate allowable is 1000 in/min as this is the maximum application rate of the Q10 labeling head.
- The final wrap speed should be set from 1.5 to 2 times the rate of the conveyor. All line compensation systems will automatically adjust the labeling head speed with respect to the speed of the wrap station .

MAINTENANCE:

- Keep the wrap belt free of label adhesive and debris. This will prevent jamming and web tears.
- Periodically check belt tension. Use the setscrew adjustment at each end to control belt tension.

CAUTION:

- **Before performing any maintenance or cleaning make sure the system is powered down.**

TROUBLESHOOTING:**PROBLEM**

- Belt not fully engaged
- Wrap station not feeding the label correctly
- Speed set incorrectly
- Belt Jam
- Tension too stiff

WHAT TO DO

- Increase tension on belt by adjusting tensioner set screws.
- Adjust wrap station inward.
- Reset speed as necessary.
- Speed set incorrectly, reset speed as necessary.
- Relieve tension.

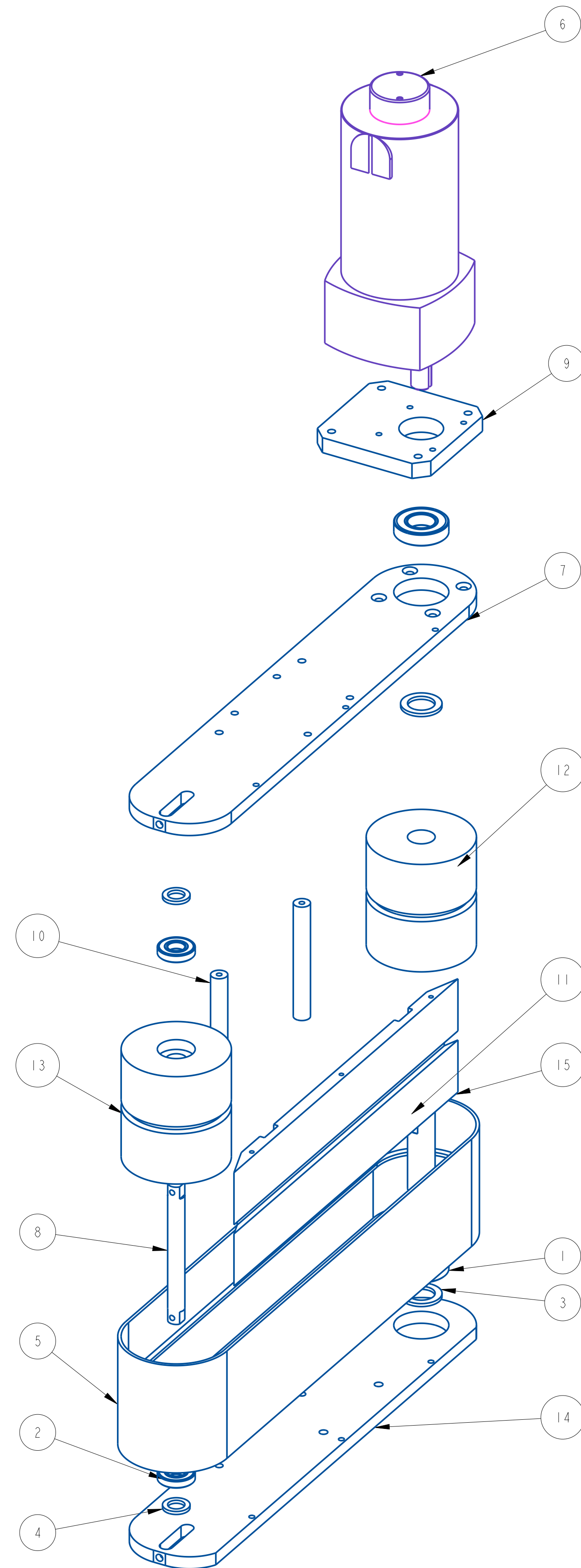

ITEM	QTY	PART NO.	DESCRIPTION	PARENT ITEM
1	2	111064-000	BEARING, BANDED THRUST BALL	22886-03LH
2	2	111075-000	BEARING, BALL	22886-03LH
3	2	151011-000	BEARING, THRUST WASHER	22886-03LH
4	2	151017-000	BEARING, THRUST WASHER	22886-03LH
5	1	193372-009	WHITE FDA LINOTEX	22886-03LH
6	1	412118-000	MOTOR, 1/4 HP 125 RPM	22886-03LH
7	1	A20053-000	LOWER PLATE, ML60 POWER BELT	22886-03LH
8	1	A21743-000	IDLER SHAFT	22886-03LH
9	1	A23731-000	MOTOR MTG. PLATE (MODULINE)	22886-03LH
10	2	A25302-007	SPACER	22886-03LH
11	1	B20776-000	DRIVE SHAFT	22886-03LH
12	1	B21968-000	DRIVE ROLL W/GROOVE	22886-03LH
13	1	B21969-000	IDLER ROLL W/GROOVE	22886-03LH
14	1	B22085-000	LOWER PLATE (MODULINE WRAP)	22886-03LH
15	1	D21858-000	BACK-UP PLATE W/ GROOVE	22886-03LH

NOT SHOWN:
A26230-009 GUARD

REV	DATE	DESCRIPTION	BY
A	Feb-12-26	NEW DRAWING	TAZ

THIS IS A PRO-ENGINEER DOCUMENT AND MAY NOT BE MODIFIED MANUALLY

<small>UNLESS OTHERWISE SPECIFIED DIMENSIONAL TOLERANCE</small> xx ± .01 xxx ± .005 ANGLES ± .30° SURFACE FINISH 125 BREAK ALL EDGES .005/.015 CORNER RADIUS .010/.030 ALL ANGLES ARE 90°		QUADREL LABELING SYSTEMS 7670 JENTHER DRIVE MENTOR, OHIO 44060 (440) 602-4700	SCALE: 11/32 DATE: Feb-12-26 DRW BY: TAZ CHK BY: APPR BY:	
		ML POWERED BACK BELT 4"x18" W/ DC MOTOR AND FDA BELT		
		MAT'L	22886-03LH	22886-03LH

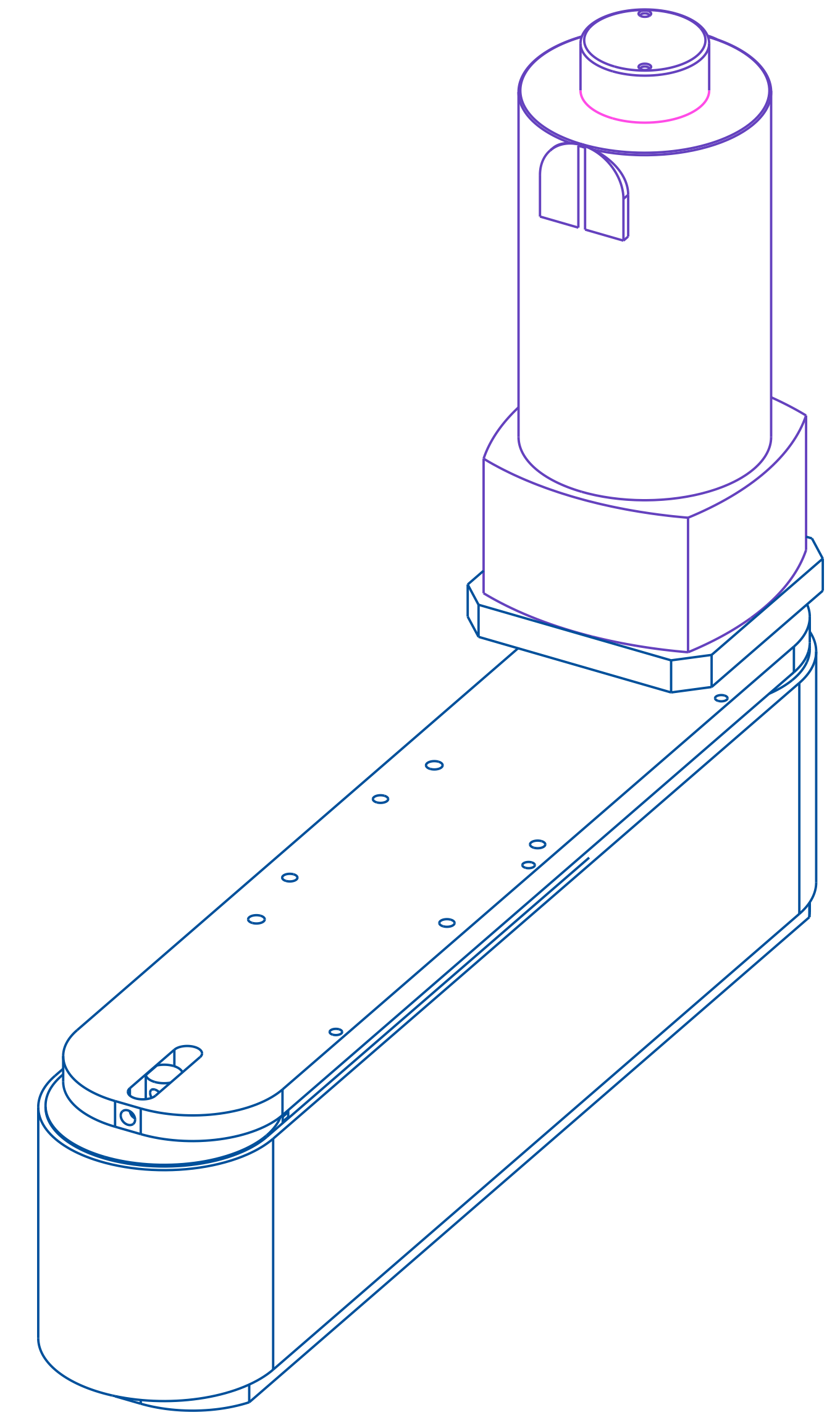
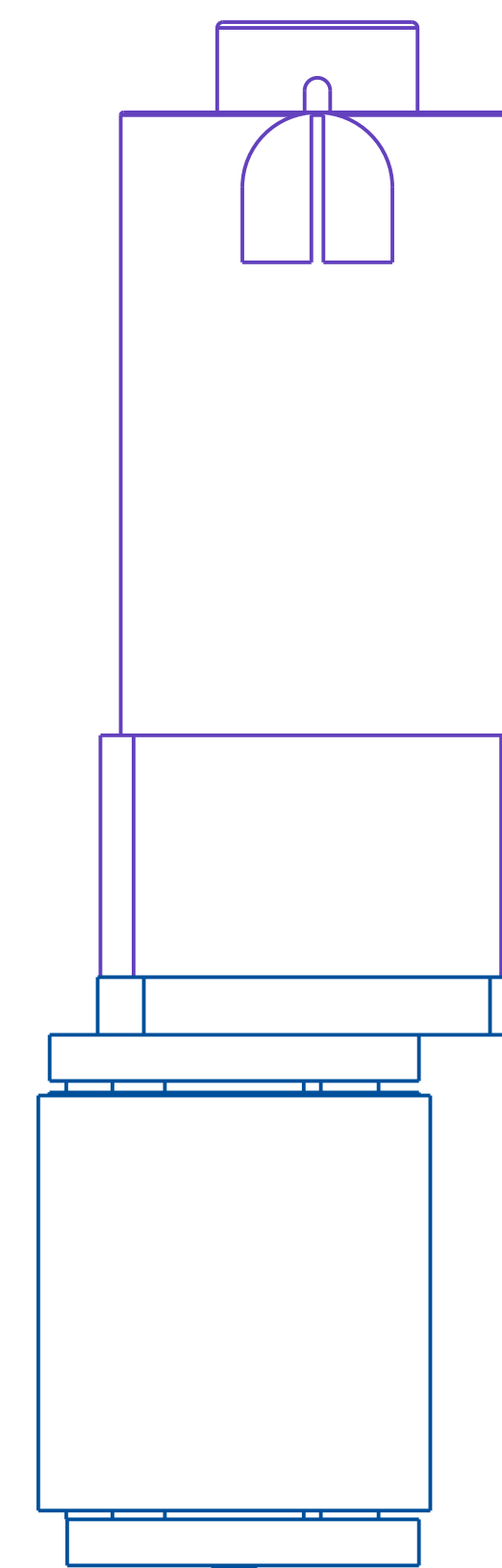
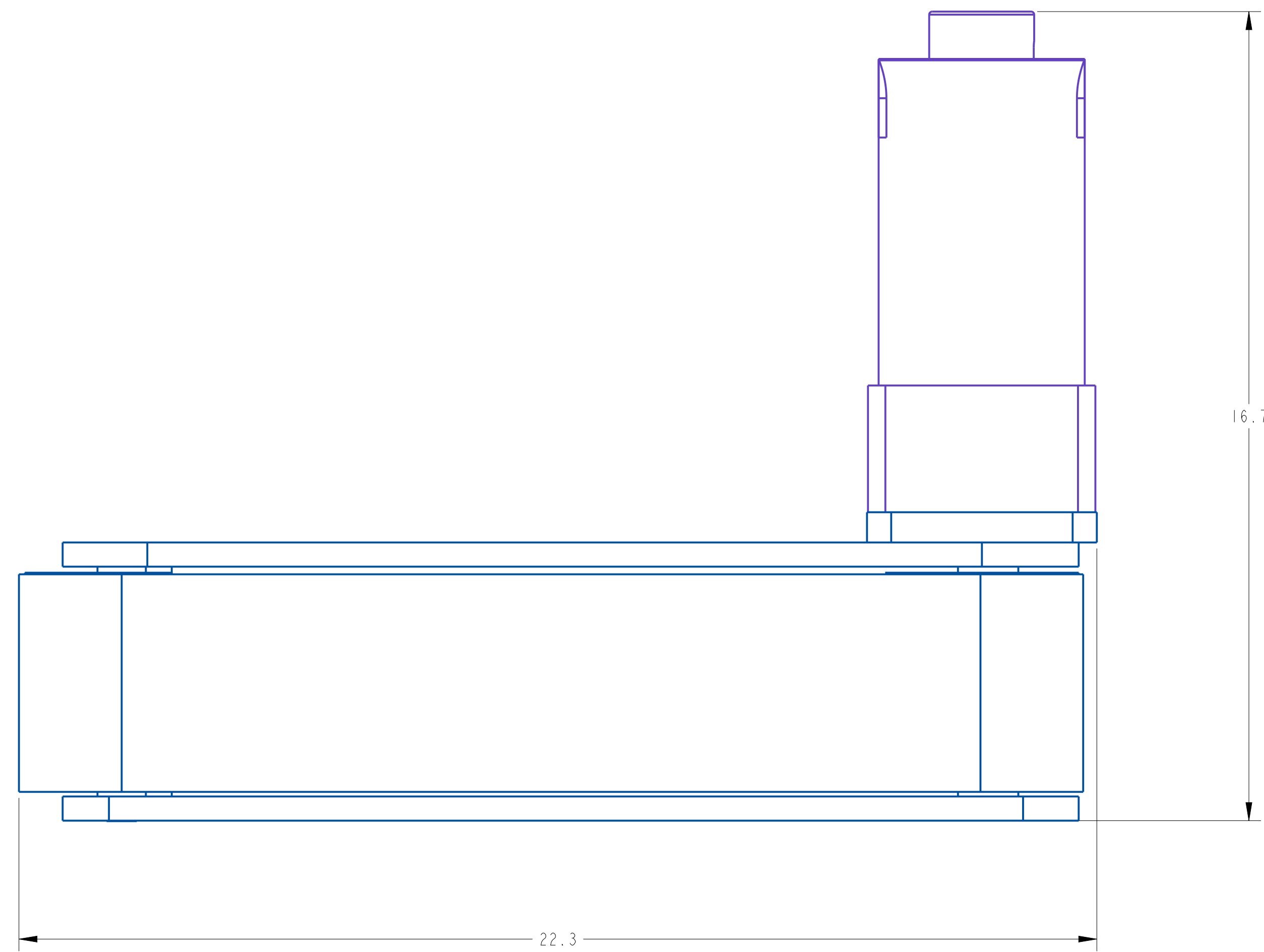
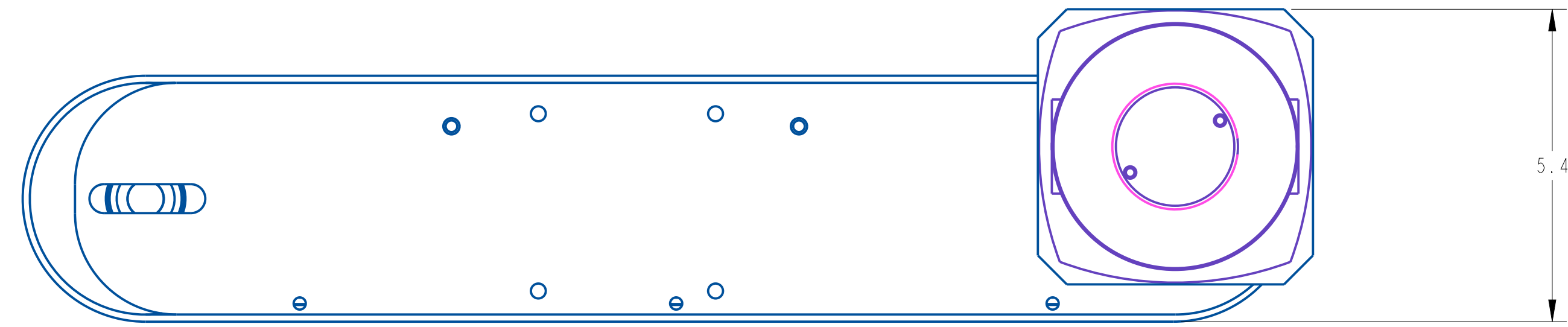

REV	DATE	DESCRIPTION	BY
A	Feb-12-26	NEW DRAWING	TAZ

THIS IS A PRO-ENGINEER DOCUMENT AND MAY NOT BE MODIFIED MANUALLY

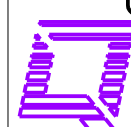
UNLESS OTHERWISE SPECIFIED DIMENSIONAL TOLERANCE .X ± .1 .XX ± .01 .XXX ± .005 ANGLES ± .30° SURFACE FINISH 125 BREAK ALL EDGES .005/.015 CORNER RADIUS .010/.030 ALL ANGLES ARE 90°	 7670 JENTHER DRIVE MENTOR, OHIO 44060 (440) 602-4700	SCALE: 1/2
		DATE: Feb-12-26
		DRW BY: TAZ
		CHK BY:
ML POWERED BACK BELT 4"X18" W/ DC MOTOR AND FDA BELT		APPR BY:
MAT'L	22886-03LH	22886-03LH

ITEM	QTY	PART NO.	DESCRIPTION	PARENT ITEM
1	2	801843-000	RATCHET HANDLE 3/8 X 16	21955-000
2	4	A21257-000	BRACKET, EQUAL LEG	21955-000
3	2	C20971-000	ML RAIL	21955-000
4	4	WA011		21955-000

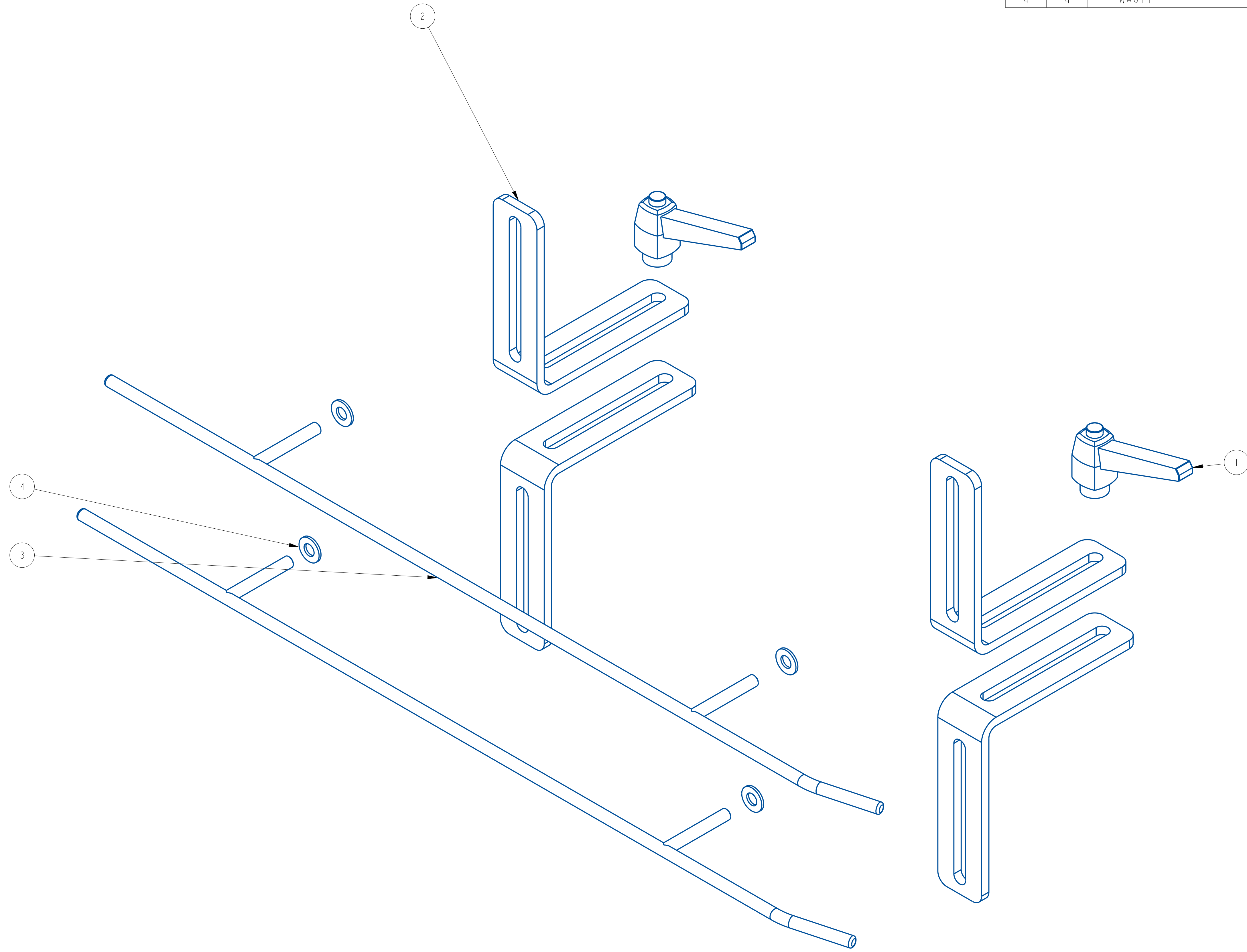

REV	DATE	DESCRIPTION	BY
A	07/25/2007	NEW DRAWING	SEM

THIS IS A PRO-ENGINEER DOCUMENT AND MAY NOT BE MODIFIED MANUALLY

UNLESS OTHERWISE SPECIFIED DIMENSIONAL TOLERANCE .X ± .1 .XX ± .01 .XXX ± .005 ANGLES ± 30°	QUADREL LABELING SYSTEMS 7670 JENTHER DRIVE MENTOR, OHIO 44060 (440) 602-4700	SCALE: 3/4 DATE: 07/25/2007 DRW BY: SEM CHK BY: 07/26/2024-SEM APPR BY:
--	---	---

ML GUIDE RAIL

MAT'L	BOM 21955-000	D21912-000
-------	---------------	------------

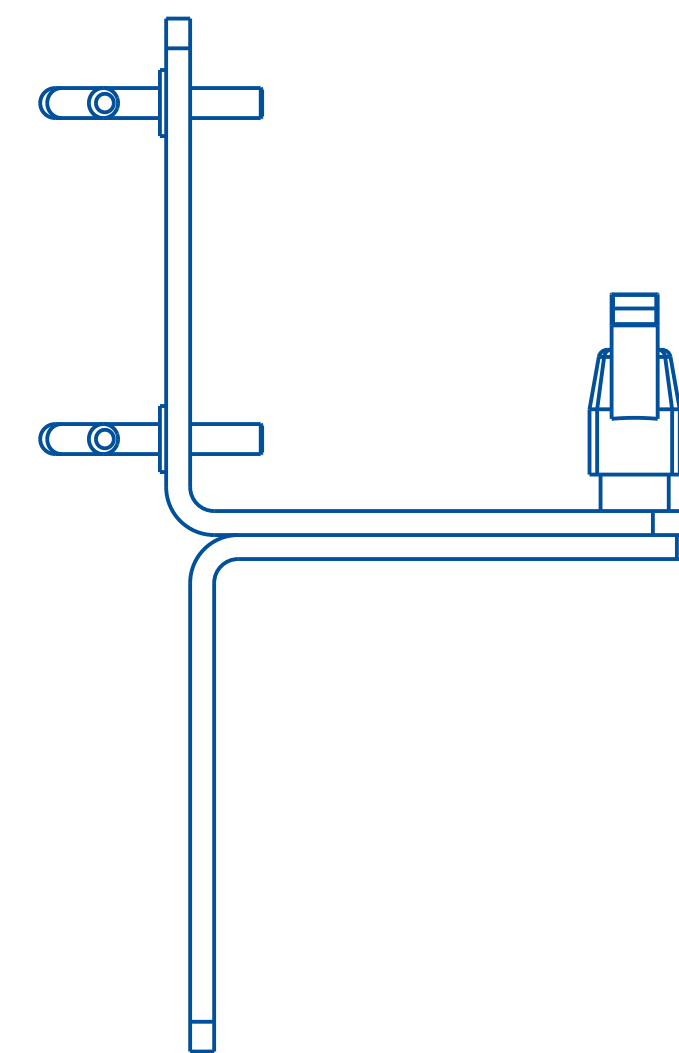
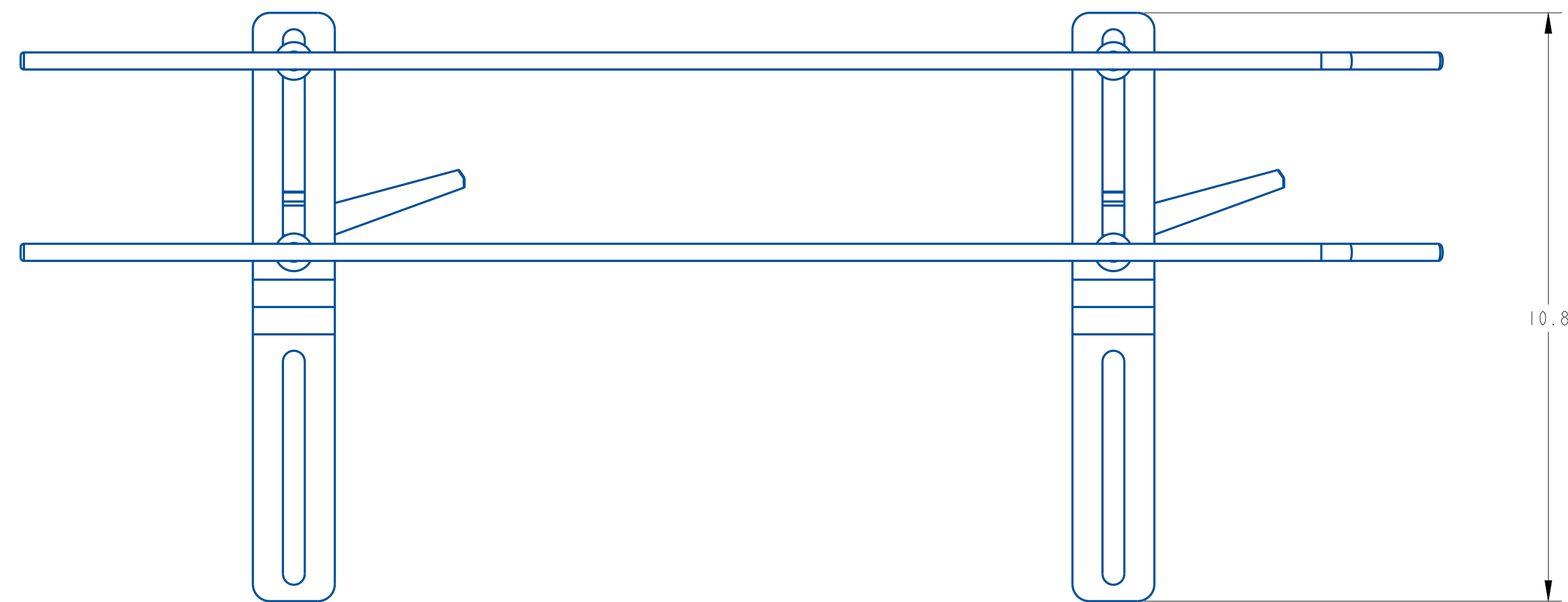
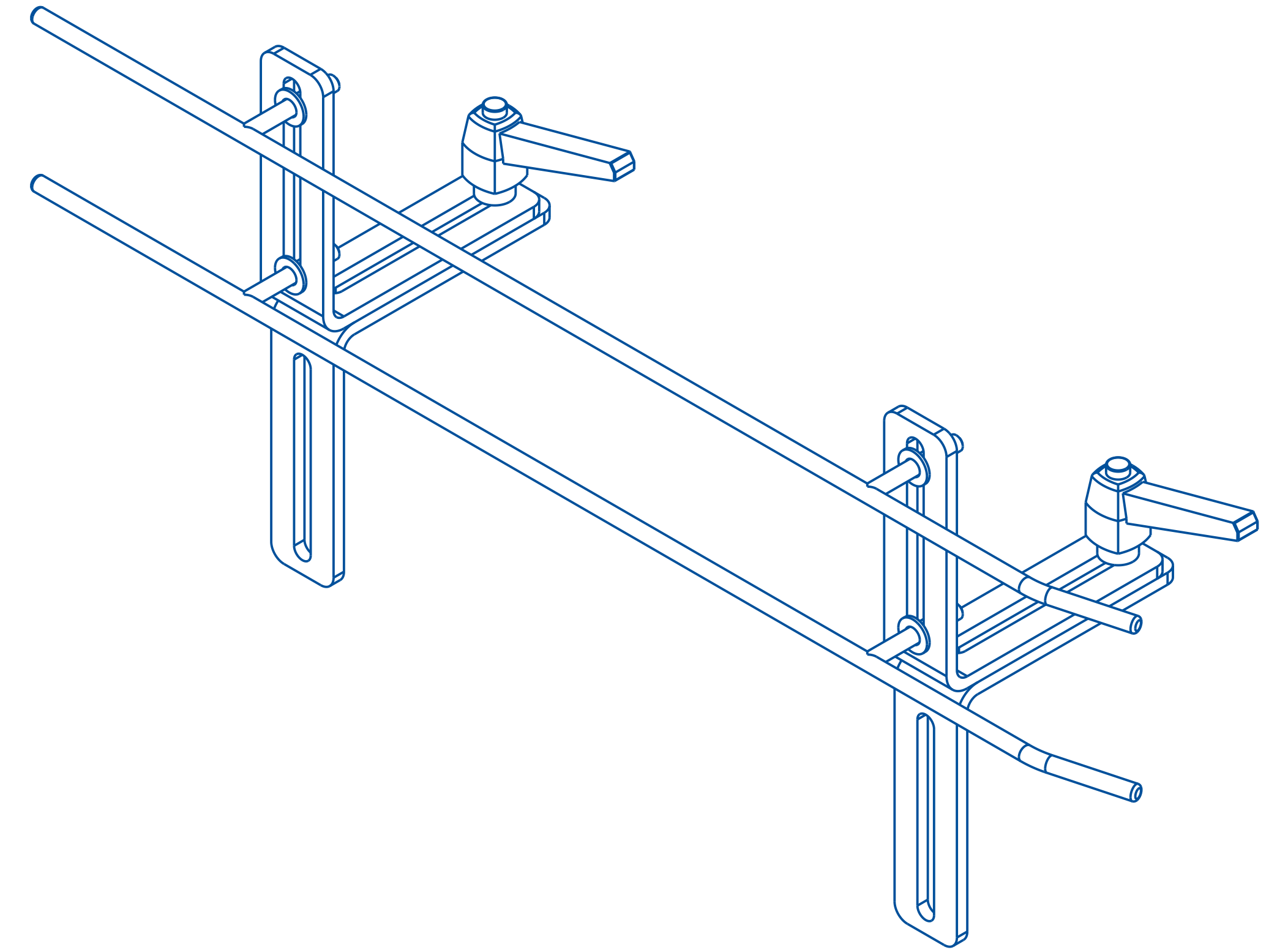
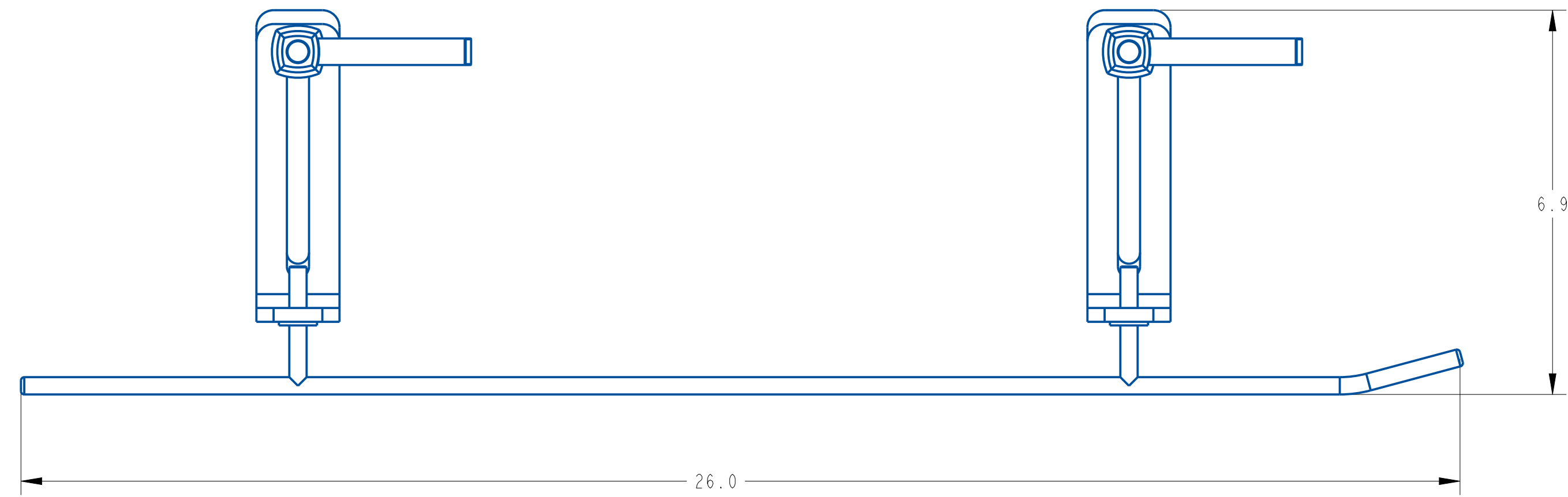

REV	DATE	DESCRIPTION	BY
A	07/25/2007	NEW DRAWING	SEM

THIS IS A PRO-ENGINEER DOCUMENT AND MAY NOT BE MODIFIED MANUALLY

UNLESS OTHERWISE SPECIFIED DIMENSIONAL TOLERANCE	x ± .1 xx ± .01 xxx ± .005 ANGLES ± .30°	SCALE: 1/2 DATE: 07/25/2007 DRW BY: SEM CHK BY: 07/26/2024-SEM APPR BY:
QUADREL LABELING SYSTEMS 7670 JENTHER DRIVE MENTOR, OHIO 44060 (440) 602-4700		
ML GUIDE RAIL		
MAT'L	BOM 21955-000	D21912-000

ASSEMBLY TITLE: PRODUCT DETECT ASSEMBLY

DRAWING NO: 21462-005

GENERAL FUNCTION:

The product detect signal is used to trigger the labeling cycle. Optimum placement and setup of the product detect sensor is critical to accurate and repeatable label placement.

SETUP AND ADJUSTMENTS:

Set the position of the product detect sensor at a point up-stream of the peel plate area. Set the vertical position of the sensor at a point on the product that provides a stable and repeatable sense area. Loosen the vertical adjustment knobs to move the assembly along the vertical axis.

Follow the manufactures data sheet for a particular set and calibration.

MAINTENANCE:

No scheduled maintenance is required for this assembly. Always keep the drive areas free of label flash and debris.

CAUTION: Before performing any maintenance or cleaning make sure the system is powered down.

TROUBLESHOOTING:

PROBLEM:

- No label trigger or intermittent trigger.

WHAT TO DO:

- Product does not intersect sensor scan field. Adjust sensor position until sensor detects product.
- Sensor gain set is too low. Increase gain until sensor indicator displays ON status(with product in sensor field).

ITEM	QTY	PART NO.	DESCRIPTION
1	2	092045-000	ROD TO ROD CROSS BLOCK
2	1	202192-002	CLEAR PRODUCT SENSOR
3	1	203160-000	REFLECTOR
4	1	A20654-001	ADJ. ROD
5	1	A23241-000	SUPPORT FOOT
6	1	A23249-000	ROD TO ROD CROSS BLOCK
7	1	A23250-000	SQUARE BAR
8	1	A23250-003	SQUARE BAR
9	1	A23250-012	SQUARE BAR

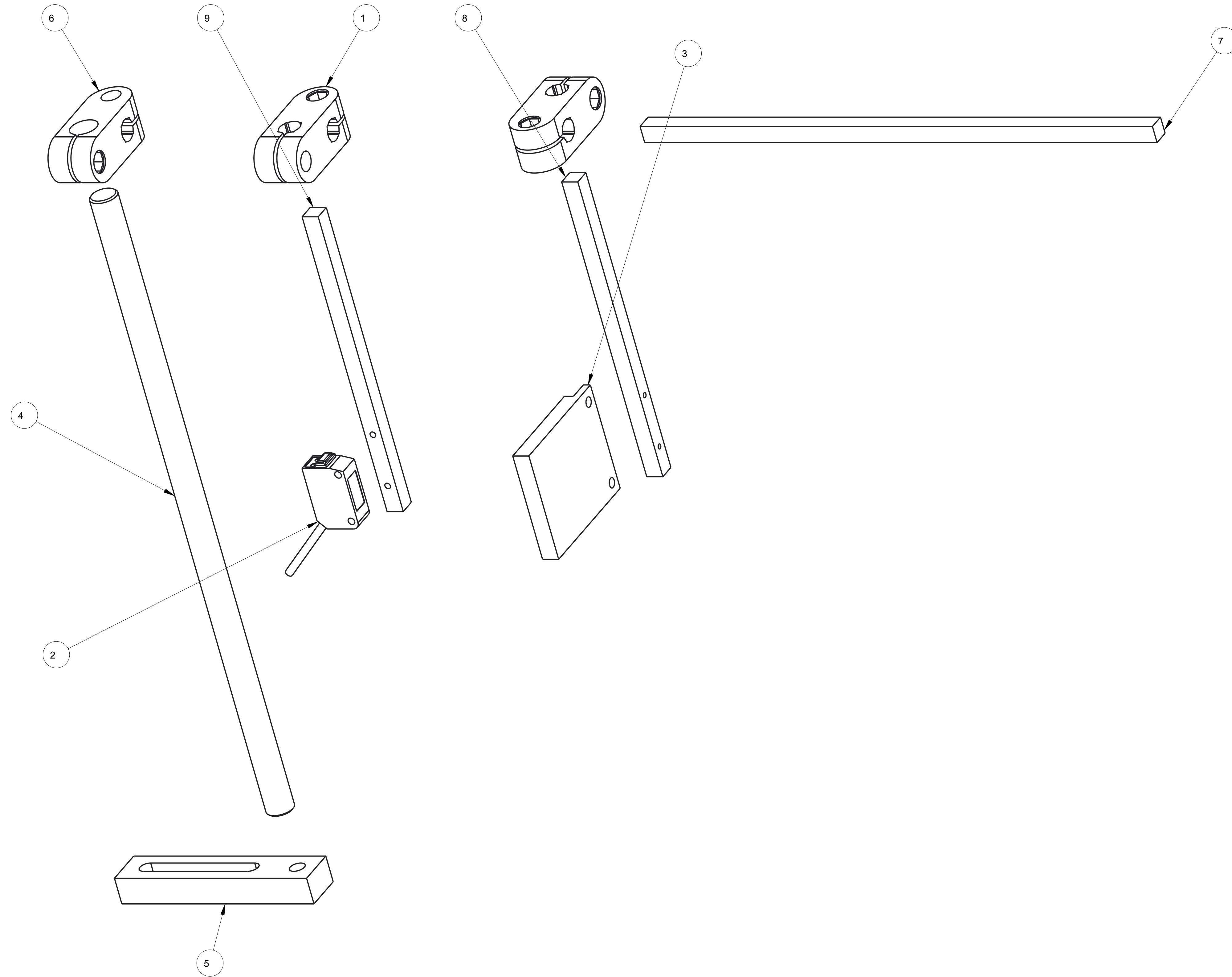

A		02-SEP-16	NEW DRAWING	CRT
REV	DATE	DESCRIPTION	BY	

THIS IS A PRO-ENGINEER DOCUMENT AND MAY NOT BE MODIFIED MANUALLY

UNLESS OTHERWISE SPECIFIED DIMENSIONAL TOLERANCE .X± .1 .XX± .01 .XXX± .005 ANGLES ± 30°	QUADREL LABELING SYSTEMS 7670 JENTHER DRIVE MENTOR, OHIO 44060 (440) 602-4700		SCALE	1/1
			DATE	02-SEP-16
			DRAWN BY	CRT
PRODUCT DETECT				
MAT'L	21462-005		21462-005	

SURFACE FINISH 125
 BREAK ALL EDGES .005/015
 CORNER RADIUS .010/030

PZ-G Series

Instruction Manual

Read this manual thoroughly before using the product.
Keep this manual readily available for future reference.

96M11227



Safety precautions

- Avoid running the PZ-G cable along with power and high voltage lines, as this may cause interference and/or permanent damage.
- When using a commercially available switching regulator, ground its chassis grounding and earth grounding terminals.
- Do not use in locations where direct ambient light or external light directly shines on the light receiving surface.
- With retro-reflective type sensors, when detecting highly reflective materials (such as mirrored surfaces), stabilization may be difficult. To correct this, change the angle of the sensor head, or adjust the sensitivity.
- Avoid using power which exceeds the specifications for ripple (10% max)
- Avoid using excess force when rotating the operation mode selector switch (Light-on, Dark-on) and the sensitivity adjustment trimmer.
- This product is just intended to detect the object(s). Do not use this product for the purpose to protect a human body or a part of human body.
- This product is not intended for use as explosion-proof product. Do not use this product in a hazardous location and/or potentially explosive atmosphere.

Precautions on Regulations and Standards

UL Certificate

This product is an UL/C-UL Listed product.

- UL File No. E301717
- Category NRKH,NRKH7
- Enclosure Type 1 (Based on UL50)

Be sure to consider the following specifications when using this product as an UL/C-UL Listed Product.

- Use the power supply with Class 2 output defined in NFPA70 (NEC: National Electrical Code).
- Power supply/ Control input/ Control output circuits shall be connected to a single Class 2 source only.
- Use with the over current protection device which is rated 30V or more and not more than 1A.

Part Names

PZ-G5xN/G5xP

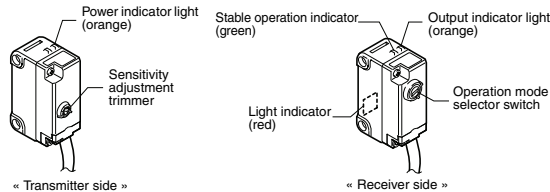

PZ-G5xB

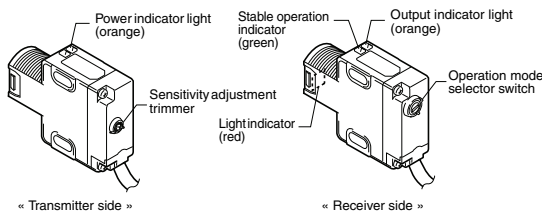

PZ-G4xN/G4xP/G10xN/G10xP/G6xN/G6xP

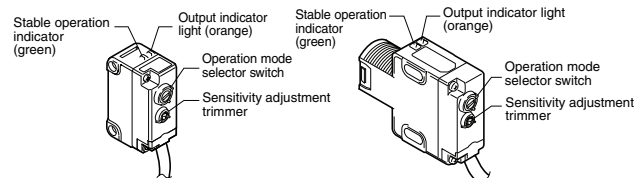

* The model name with "C" (PZ-GxxCx) is the connector type, and the model name with "E" (PZ-GxxEx) is the pigtail quick disconnect type.

Mounting Method

Side Mounting (Prepare M3 screws)

Tightening torque: 0.5 N·m or less

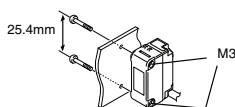

Tightening torque: 0.5 N·m or less

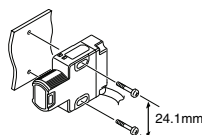

Mounting with the M18 nut (includes nut type)

The M18 nut is also available separately as OP-84225 (2 pcs. supplied).
Tightening torque: 1.0 N·m or less

Panel (5 mm or less)

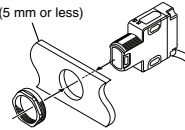

Panel cut size

$\phi 18.5 \pm 0.2$ mm

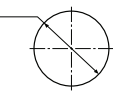

Note

- Mount the M18 nut (supplied) straight in. If mounted at an angle it cannot be tightened properly.
- When tightening the M18 nut (supplied), firmly hold the main body down. The case of the main body may be damaged if held in place with a tool such as pliers.
- When tightening the M18 nut (supplied), if excess force is applied to the nut with a tool such as pliers, it may bend it out of shape. Therefore, do not apply excess force.

Sensitivity Adjustment Method

Caution



Avoid using excess force when rotating the sensitivity adjustment trimmer and operation mode selector switch as it may cause damage.

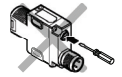

Operation mode selector switch

With the operation mode selector switch, you can select either the LIGHT-ON mode (L) or the DARK-ON (D) mode.



Reflective type (PZ-G41/G42/G101/G102/G10R/G10G/G10B Series)

The following assumes LIGHT-ON (L) is set.

Sequence	Adjustment method	Sensitivity adjustment trimmer
①	Position target in place. Slowly rotate the sensitivity trimmer from the MIN position towards the MAX position until the (orange) output indicator turns on (Position "A"). If the output indicator does not turn off, even at MIN, then MIN is considered Position "A".	
②	Remove the target. Adjust the sensitivity trimmer from MIN towards MAX until the (orange) output indicator turns on (Position "B"). If the output indicator does not light up, the MAX position is considered Position "B".	
③	Adjust the sensitivity trimmer to the midpoint between "A" and "B". Verify that the (green) stable operation light turns on with and without a target in place.	

Reference To use the sensor in DARK-ON mode, adjust the mode selector switch to "D".

Thrubeam type (PZ-G51/G52 Series) / Retro-reflective type (PZ-G61/G62 Series)

The following assumes DARK-ON (D) is set.

Sequence	Adjustment method	Sensitivity adjustment trimmer
①	Remove the target. Adjust the sensitivity trimmer to MAX. Mount the sensor heads in place so the (orange) output indicator turns off (on thrubeam models, the red light on the receiver face will turn on)	
②	Position target in place. Verify that the orange output indicator turns on (on thrubeam models, the red light on the receiver face will turn off). Adjust sensitivity lower if the output indicator does not turn on (or if the red light on the receiver face does not turn off on thrubeam models)	

Reference To use the sensor in LIGHT-ON mode, adjust the mode selector switch to "L".

I/O Circuit Diagram

PZ-G5xN/G5xP/G5xB (Transmitter side)

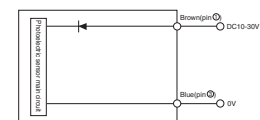

PZ-G5xN (Receiver side)/ G4xN/G10xN/G6xN

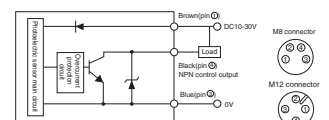

PZ-G5xP (Receiver side)/ G4xP/G10xP/G6xP

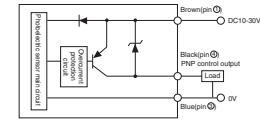

PZ-G5xB (Receiver side)/ G4xB/G10xB/G6xB

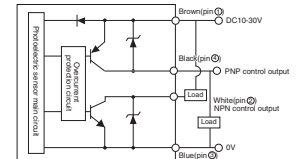

* The pin numbers represent those of the connector type / pigtail quick disconnect type. The model name with "C" (PZ-GxxCx) is the connector type, and the model name with "E" (PZ-GxxEx) is the pigtail quick disconnect type.

[PZ-GxxCN/GxxCP..... M8 connector
PZ-GxxCB/GxxEN/GxxEP..... M12 connector]

Indicators

The following describes each ON/OFF condition of indicator when LIGHT-ON (L) is set.

Reference When the DARK-ON (D) is set, the output indicator ON/OFF will reverse.

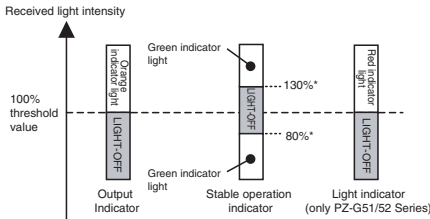

* For PZ-G62, the upper limit is 107% and the lower limit is 93%.

If the stable operation indicator turns off during operation, readjust or fine-adjust the sensitivity.

Mutual interference

- For reflective type / retro-reflective type sensors, mutual interference protection can be set for up to 2 units. However, when the sensors are mounted facing each other, change the angle of the sensor head to prevent light being emitted into each unit. (The mark detection type does not include the mutual interference function.)
- Mutual interference prevention can be set when mounting a polarizing filter attachment (optional with thru-beam type sensors) (If operation is unstable even after mounting the polarizing filter, slightly lower the sensitivity.)
- For more detailed information about mutual interference or attachment, see the PZ-G Series catalog or contact your nearest KEYENCE office.

Specifications

Type		Thru-beam		Reflective				Retro-reflective		Mark detection						
Configuration	Cable shape	Output mode	Normal	High-power	Diffuse-reflective Long-detecting distance	Diffuse-reflective Short-detecting distance	Narrow-view reflective	Definite reflective	Long detecting distance (with P.R.O. function)	Transparent target detection (without P.R.O. function)	Red	Green	Blue			
Rectangular	Cable	NPN	PZ-G51N	PZ-G52N	PZ-G41N	PZ-G42N	PZ-G101N	PZ-G102N	PZ-G61N	PZ-G62N						
		PNP	PZ-G51P	PZ-G52P	PZ-G41P	PZ-G42P	PZ-G101P	PZ-G102P	PZ-G61P	PZ-G62P						
	M8 connector	NPN	PZ-G51CN	PZ-G52CN	PZ-G41CN	PZ-G42CN	PZ-G101CN	PZ-G102CN	PZ-G61CN	PZ-G62CN				PZ-G10RCN	PZ-G10GCN	PZ-G10BCN
		PNP	PZ-G51CP	PZ-G52CP	PZ-G41CP	PZ-G42CP	PZ-G101CP	PZ-G102CP	PZ-G61CP	PZ-G62CP				PZ-G10RCP	PZ-G10GCP	PZ-G10BCP
Nut	Cable	NPN	PZ-G51EN	PZ-G52EN	PZ-G41EN	PZ-G42EN	PZ-G101EN	PZ-G102EN	PZ-G61EN	PZ-G62EN						
		PNP	PZ-G51EP	PZ-G52EP	PZ-G41EP	PZ-G42EP	PZ-G101EP	PZ-G102EP	PZ-G61EP	PZ-G62EP						
Nut	M12 connector	Bipolar	PZ-G51B	PZ-G52B	PZ-G41B	PZ-G42B	PZ-G101B	PZ-G102B	PZ-G61B	PZ-G62B						
		(NPN+PNP)	PZ-G51CB	PZ-G52CB	PZ-G41CB	PZ-G42CB	PZ-G101CB	PZ-G102CB	PZ-G61CB	PZ-G62CB						
Detecting distance ¹			20 m	40 m	1 m (30 x 30 cm white mat paper)	300 mm (10 x 10 cm white mat paper)	200 mm	5 to 45 mm	0.1 to 4.2 m (when R-2L reflector is used)	0.1 to 1 m (when R-2L reflector is used)	8 to 15 mm					
Spot diameter			-	-	-	-	Approx. φ 5 mm (when the detecting distance is 100 mm)	Approx. φ 2 mm (when the detecting distance is 40 mm)	-	-	Approx. 1.5 x 4 mm (when the detecting distance is 10 mm)					
Light source (LED)			Red LED	Infrared LED x 2	Red LED				Infrared LED		Red LED	Green LED	Blue LED			
Sensitivity adjustment		1-turn trimmer (230 degrees)														
Response time		500 μs										50 μs				
Operation mode		LIGHT-ON/DARK-ON, trimmer-selectable														
Indicator (LED)		Transmitter: power (orange) Receiver: output (orange), stable operation (green), light (red)			Output (orange), stable operation (green)											
Control output		Open-collector 100 mA max. (30 V max.), Residual voltage 1 V max.														
Protection circuit		Reverse-polarity protection, over-current protection, output surge absorber														
Ratings	Power voltage	10 to 30 VDC, Ripple (P-P): ±10% max, Class 2.														
	Current consumption	Transmitter: 20 mA max. Receiver: 28 mA max.	Transmitter: 25 mA max. Receiver: 28 mA max.	34 mA max.												
Environmental resistance	Enclosure rating	IEC/JEM: IP67 / NEMA: 4X,6,12 / DIN: IP69K														
	Ambient light	Incandescent lamp: 5,000 (lx) max, Sunlight: 20,000 (lx) max.														
	Ambient temperature	-20 °C to +55 °C (No freezing)														
	Relative humidity	35 to 85 % RH (No condensation)														
	Vibration resistance	10 to 55 Hz, 1.5 mm double amplitude in X, Y, Z directions, 2 hours each														
Shock resistance	1000 m/s ² in X, Y, Z directions, 6 times each															
Interference prevention		2 units (when polarizing filter attachment is used)		2 units (with the automatic different cycle function)												
Material		Case, M18 nut (nut type only): reinforced glass polybutylene terephthalate (PBT), Trimmer: reinforced glass polyamide (PA) Cable (Cable type / pigtail quick disconnect type only): Polyvinyl chloride (PVC), Screw (Case connection): Steel, zinc-nickel plated, Packing (Case connection): Nitrile-butadiene rubber (NBR) Connector (pigtail quick disconnect type only): Brass-nickel plated, Polybutylene terephthalate (PBT), Polyvinyl chloride (PVC)														
Lens cover		Polyarylate (PAR)				Acrylic plastic (PMMA)			Polyarylate (PAR)							
Tightening torque		Rectangular type (side screw part): 0.5 N·m max. Nut type (front M18 part): 1.0 N·m max., (side slot part): 0.5 N·m max.														
Accessory ²		Instruction manual, M18 nut x 2 (nut thru-beam type), M18 nut x 1 (other nut types)														
Weight		Rectangular cable type: Approx. 60 g (Approx. 50 g for thru-beam transmitter), Rectangular M8 connector type: Approx. 10 g, rectangular M12 pigtail quick disconnect type: Approx. 30 g Nut type cable type: Approx. 65 g (Approx. 55 g for thru-beam transmitter), Nut type M12 connector type: Approx. 15 g														

¹ The detection distance is measured with the maximum sensitivity.

² The cable for the connector type / pigtail quick disconnect type is sold separately. The reflector for the retro-reflective type is sold separately.

WARRANTY

KEYENCE products are strictly factory-inspected. However, in the event of a failure, contact your nearest KEYENCE office with details of the failure.

1. WARRANTY PERIOD

The warranty period shall be for one year from the date that the product has been delivered to the location specified by the purchaser.

2. WARRANTY SCOPE

(1) If a failure attributable to KEYENCE occurs within the abovementioned warranty period, we will repair the product, free of charge. However, the following cases shall be excluded from the warranty scope.

- Any failure resulting from improper conditions, improper environments, improper handling, or improper usage other than described in the instruction manual, the user's manual, or the specifications specifically arranged between the purchaser and KEYENCE.
- Any failure resulting from factors other than a defect of our product, such as the purchaser's equipment or the design of the purchaser's software.
- Any failure resulting from modifications or repairs carried out by any person other than KEYENCE staff.
- Any failure that can certainly be prevented when the expendable part(s) is maintained or replaced correctly as described in the instruction manual, the user's manual, etc.
- Any failure caused by a factor that cannot be foreseen at a scientific/technical level at the time when the product has been shipped from KEYENCE.
- Any disaster such as fire, earthquake, and flood, or any other external factor, such as abnormal voltage, for which we are not liable.

(2) The warranty scope is limited to the extent set forth in item (1), and KEYENCE assumes no liability for any purchaser's secondary damage (damage of equipment, loss of opportunities, loss of profits, etc.) or any other damage resulting from a failure of our product.

3. PRODUCT APPLICABILITY

KEYENCE products are designed and manufactured as general-purpose products for general industries.

Therefore, our products are not intended for the applications below and are not applicable to them. If, however, the purchaser consults with us in advance regarding the employment of our product, understands the specifications, ratings, and performance of the product on their own responsibility, and takes necessary safety measures, the product may be applied. In this case, the warranty scope shall be the same as above.

- Facilities where the product may greatly affect human life or property, such as nuclear power plants, aviation, railroads, ships, motor vehicles, or medical equipment
- Public utilities such as electricity, gas, or water services
- Usage outdoors, under similar conditions or in similar environments

E 1040-1

KEYENCE CORPORATION

1-3-14, Higashi-Nakajima, Higashi-Yodogawa-ku,
Osaka, 533-8555, Japan

PHONE: +81-6-6379-2211 www.keyence.com

Specifications are subject to change without notice.

A7WW1-MAN-0069

Copyright (c) 2010 KEYENCE CORPORATION. All rights reserved.

11227E 1070-1 96M11227J

Printed in Japan



Electronics

--	22513-004	1	Servo Cables, 5m
--	222397-002	1	Enclosure, 20x20x12
--	222026-001	1	Panel, 20x20
--	251799-000	3	End Cap
--	251859-000	2	10 Position Jumper, ST1.5
--	251853-000	40	Terminal Block, ST1.5, Spring
--	251854-000	8	Ground Terminal, ST1.5
--	251795-000	6	Phoenix Contact 3022276 End Terminal
--	251798-000	2	Partition Plate, ST2,5
--	251801-000	2	2 Position Jumper, ST2.5
--	251797-000	4	Phoenix Contact Terminal Block, ST2.5
--	251796-000	2	Phoenix Contact 3031238 Ground Terminal
--	241061-000	2	Fuse, 1A
--	241053-000	2	Fuse, 3A
--	241060-000	2	Fuse, 5A
13	263824-000	1	DC Drive Inhibit Connector
12	411457-000	1	DC Drive, Minarik MM23001C
11	202607-000	1	Contactur Surge Suppressor
10	202604-000	1	Contactur, 24V
9	251788-001	6	Fuse Holder, 300V, Indicating
8	241116-001	1	Circuit Breaker, 2 Pole, 10A
7	272117-003	1	Disconnect, 25A Base Mount
6	211548-003	1	Power Supply, 48V, 10A
5	221678-000	1	Regeneration Clamp
4	202628-000	2	Relay, 24V, Single
3	262821-000	1	PLC 232 Cable, 1ft
2	221717-001	1	PLC, Keyence KV-N24DTP
1	211528-005	1	24VDC Supply, 2.5A

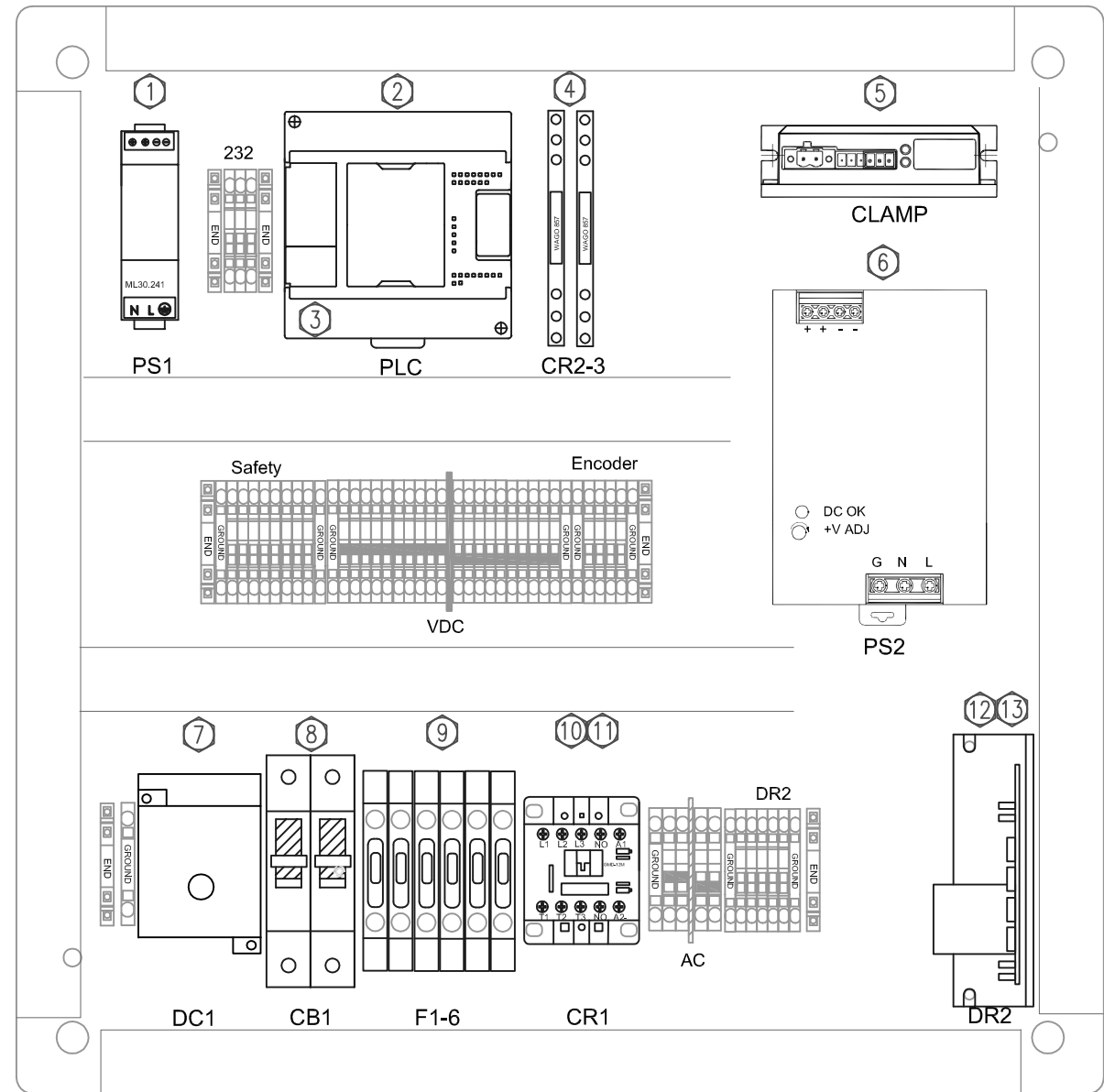

3/4" Wireway Unless Noted
Component Hardware: 8-32 SHCS
Wireway/Din Rail Hardware: 8-32 BHCS

UNLESS OTHERWISE SPECIFIED DIMENSIONAL TOLERANCE .X ± .XTOL .XX ± .XXTOL .XXX ± .XXXTOL ANGLES ± ANG.TOL SURFACE FINISH FINISHTOL BREAK ALL EDGES .005/.015 CORNER RADIUS .010/.030	QUADREL LABELING SYSTEMS 7670 Jenther Drive Mentor, Ohio 44060 (440) 602-4700	SCALE: 1:1
		DATE: 09FEB2024
		DRAWN BY: CAV
		REVISED:
	ML60/125 Servo Panel Layout	
	MAT'L 22601E-008	B22601E-007P

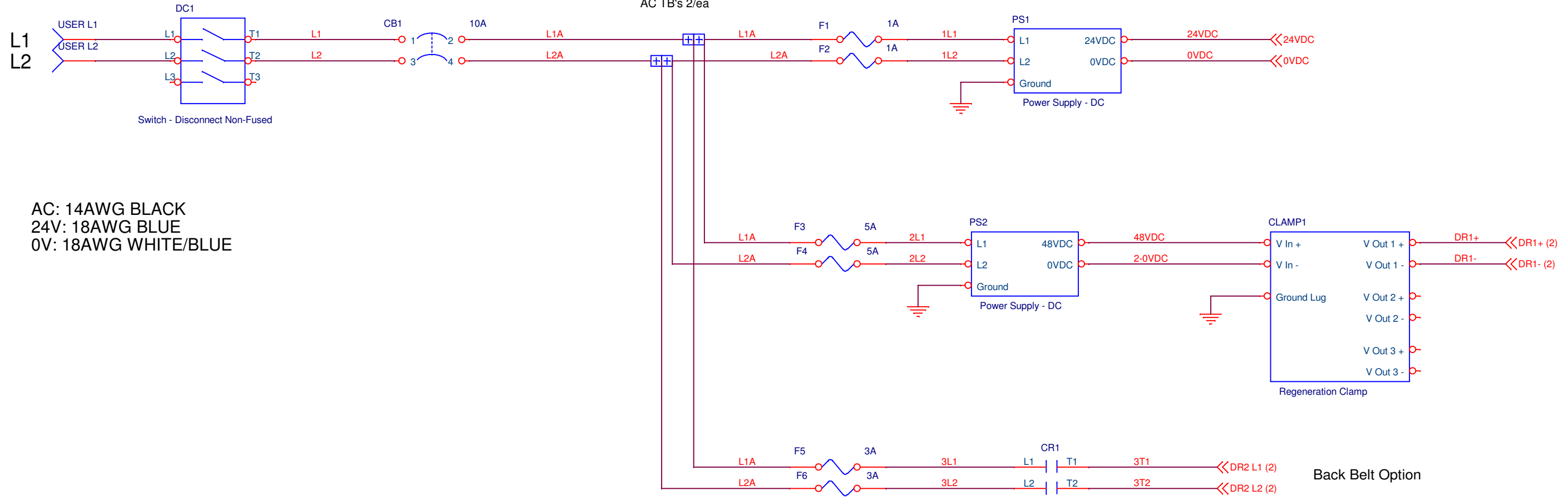

AC: 14AWG BLACK
24V: 18AWG BLUE
0V: 18AWG WHITE/BLUE

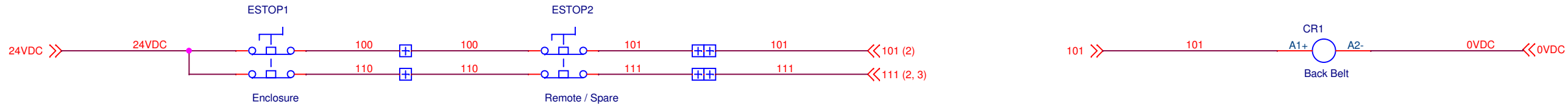

Jump EStop 2 Terminals if Not Installed

QUADREL			
LABELING SYSTEMS			
7670 JENTHER DR.			
MENTOR, OH			
44060			
Drawn By: CAV	REV	DESCRIPTION	BY DATE
	B	Encoder Options	CAV 13JUN2024
	A	Updated Wiring	CAV 22MAY2024
	-	Release	CAV 30APR2024
POWER, SAFETY			
Schematic #			Rev
SB22601-009			B
Date: Thursday, June 13, 2024		Sheet	01 of 04

To Change Encoder Count Polarity: Swap A and B wiring

Labeler #1

Cable Assy
Verify "1" and "2" on Wires Before Terminating!

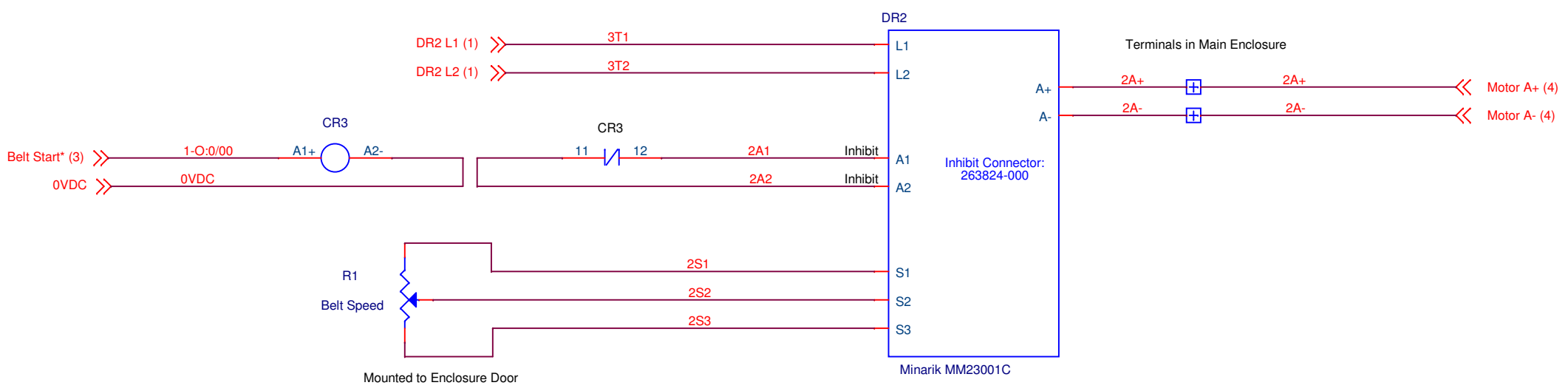
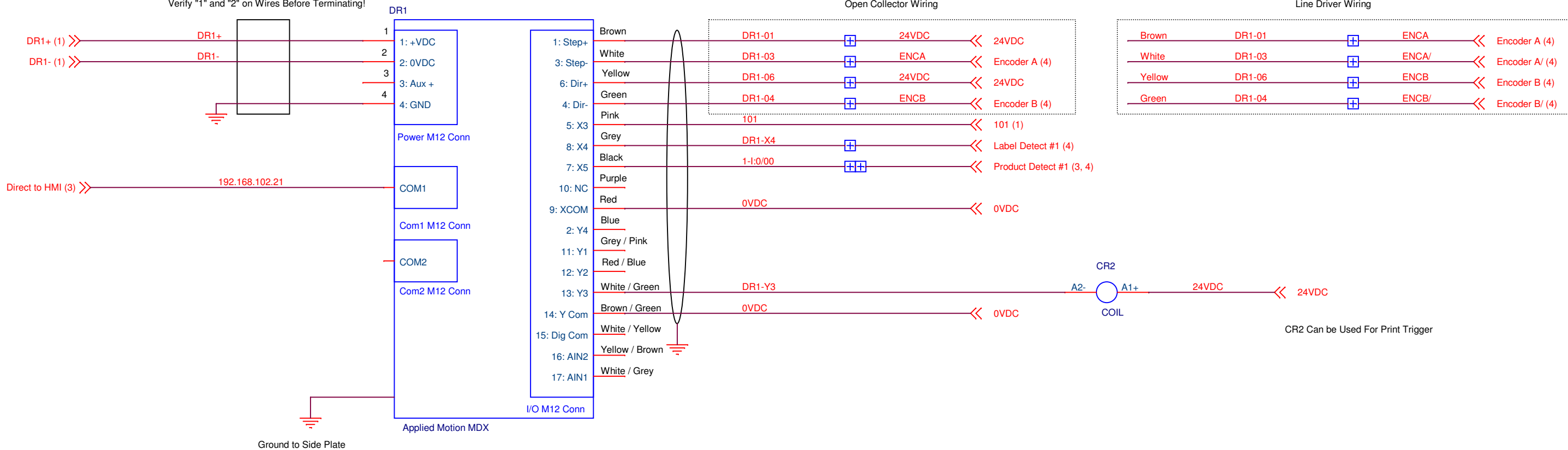

*Belt Start Option:
Use Stop Gate Output if Belt is to Start/Stop with External Sensors

QUADREL			
LABELING SYSTEMS			
7670 JENTHER DR.			
MENTOR, OH			
44060			
Drawn By: CAV	REV	DESCRIPTION	BY DATE
	B	Encoder Options	CAV 13JUN2024
	A	Updated Wiring	CAV 22MAY2024
	-	Release	CAV 30APR2024
Labeler, Back Belt			
Schematic #			Rev
SB22601-009			B
Date: Wednesday, July 10, 2024			
Sheet 02 of 04			

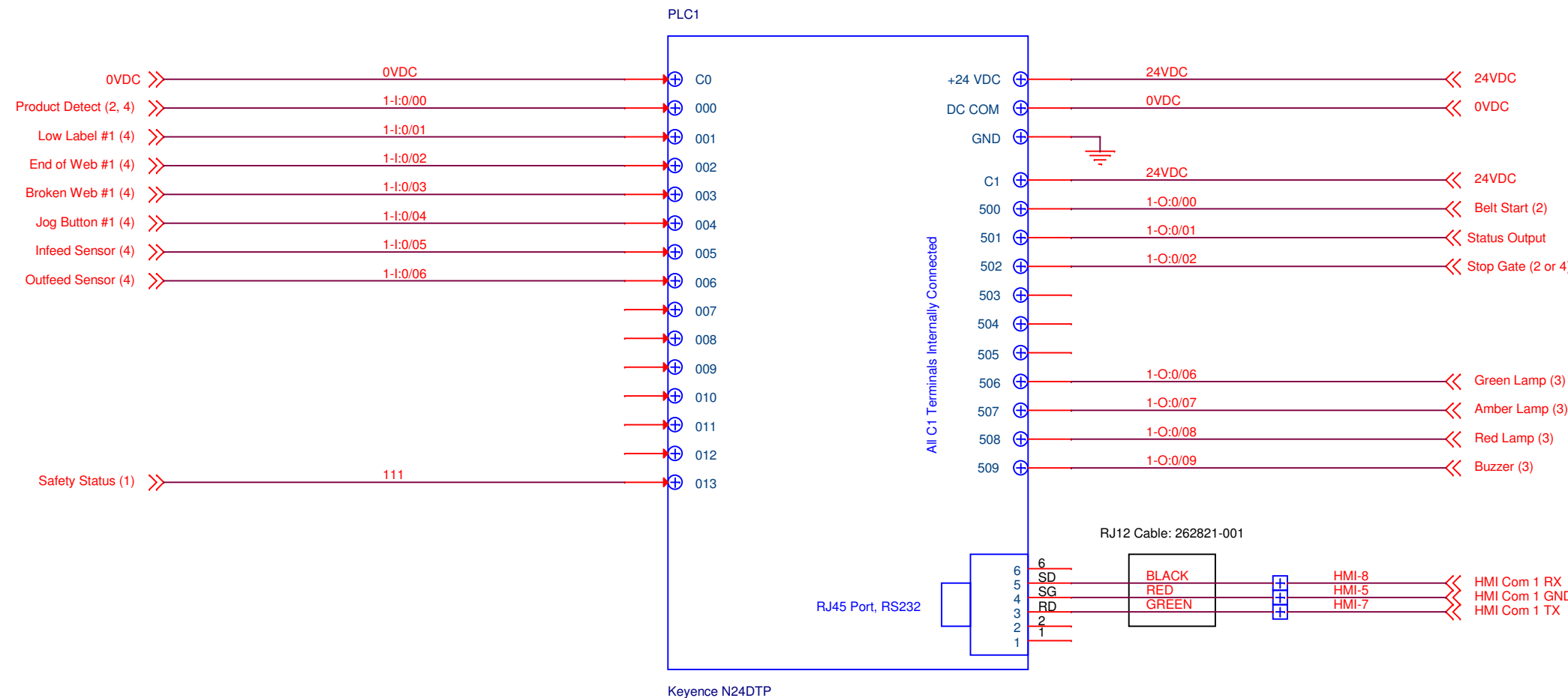

Status Output:
Signal On/High when Labeler OK

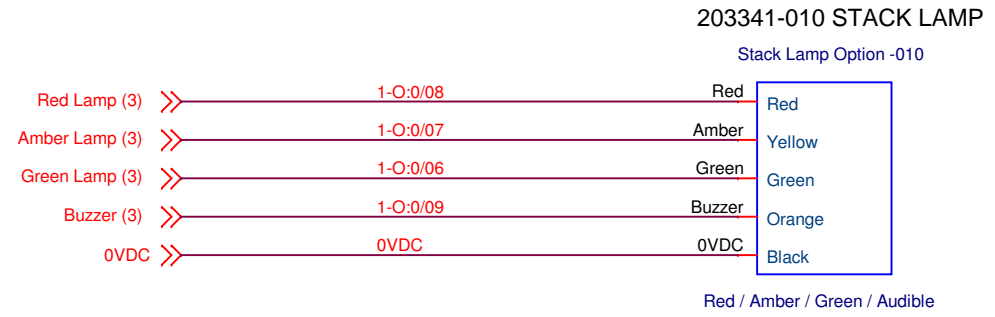
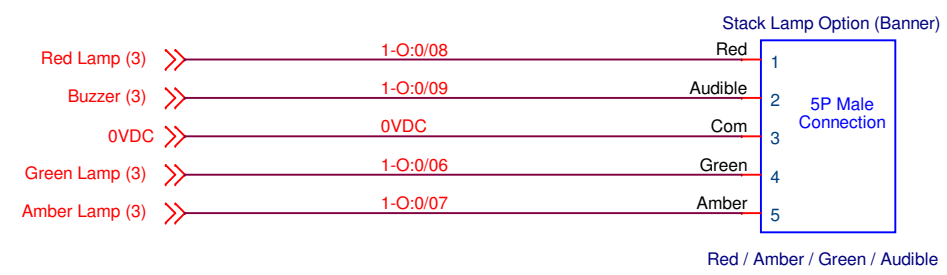
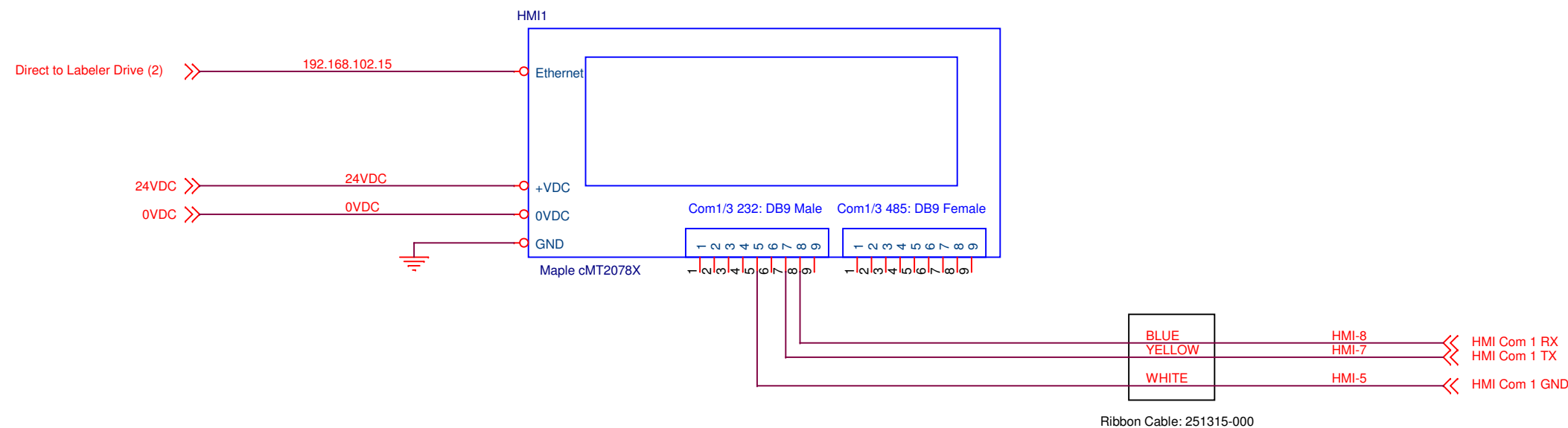

QUADREL LABELING SYSTEMS			
7670 JENTHER DR. MENTOR, OH 44060			
B	Encoder Options	CAV	13JUN2024
A	Updated Wiring	CAV	22MAY2024
-	Release	CAV	30APR2024
REV	DESCRIPTION	BY	DATE
Title PLC, HMI			
Schematic # SB22601-009			Rev B
Date: Thursday, June 13, 2024 Sheet 03 of 04			

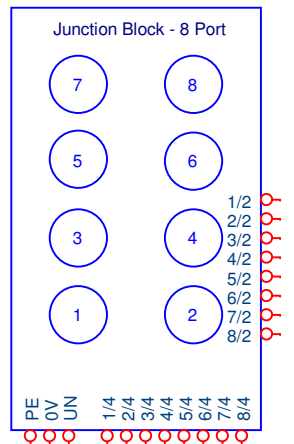
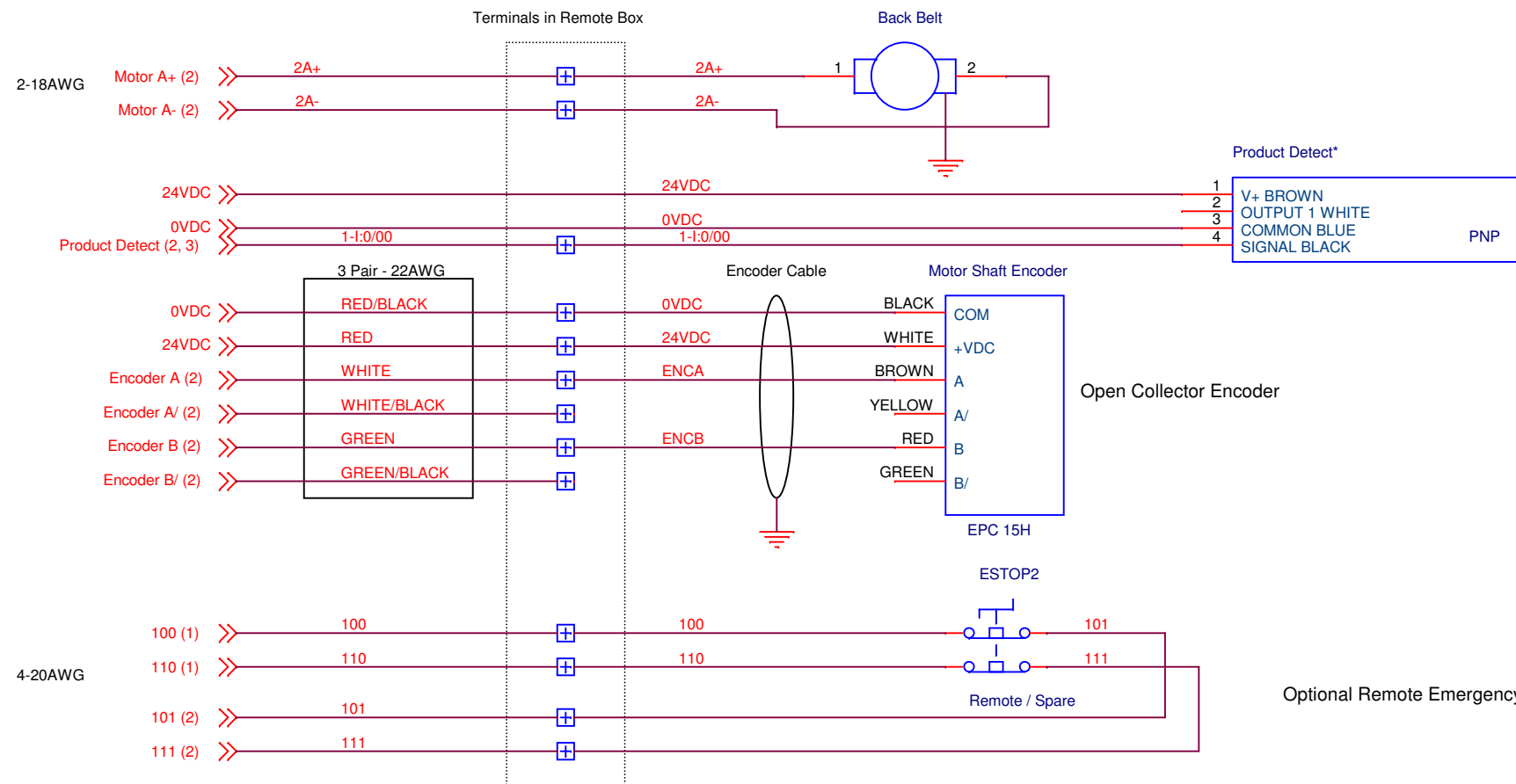

All Sensors: PNP

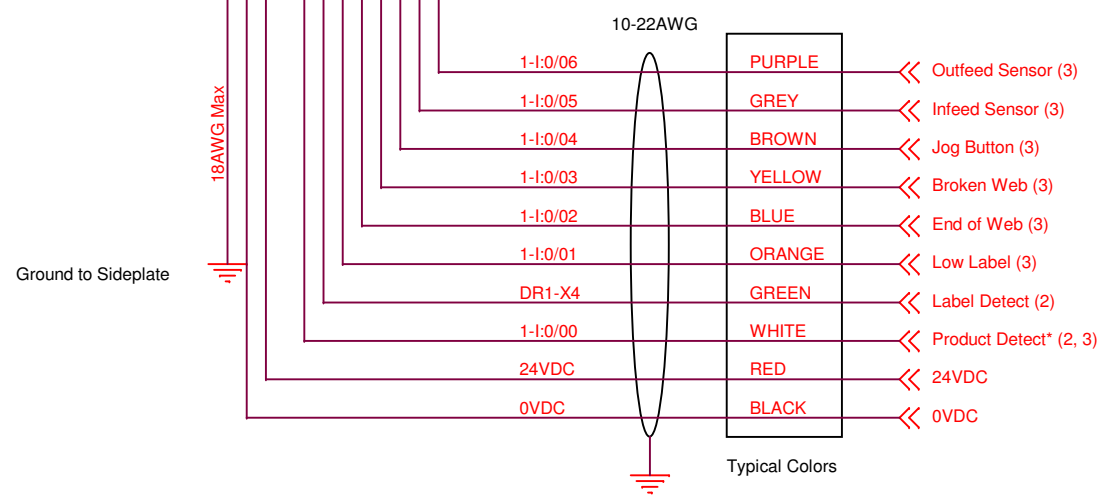
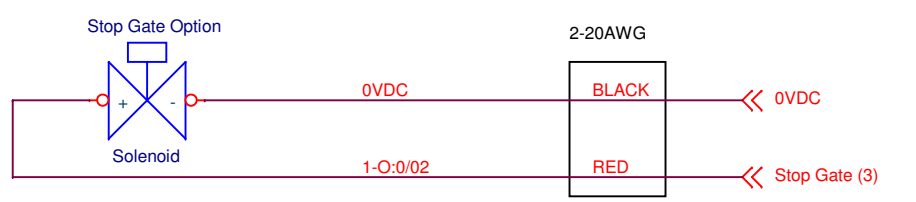
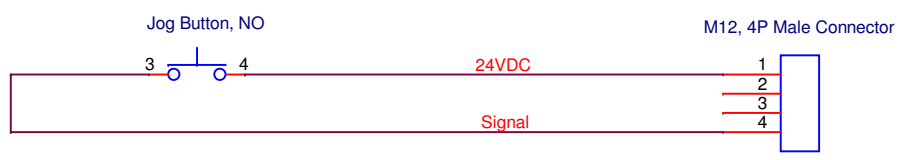
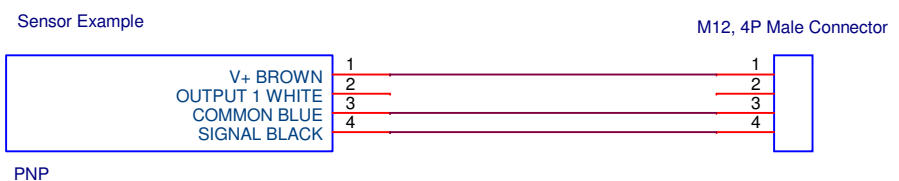

Ground from Sideplate to Enclosure Panel

*Product Detect to Junction Block if not Mounted to Back Belt

QUADREL LABELING SYSTEMS			
7670 JENTHER DR. MENTOR, OH 44060			
REV	DESCRIPTION	BY	DATE
B	Encoder Options	CAV	13JUN2024
A	Updated Wiring	CAV	22MAY2024
-	Release	CAV	30APR2024
Title: SENSORS			
Schematic #: SB22601-009			Rev: B
Date: Thursday, November 14, 2024 Sheet 04 of 04			

9 MAINTENANCE

9.1 GENERAL INFORMATION

This labeler has been designed with the minimal maintenance requirement possible. There are however some things to take into consideration.

The system is built to perform in humid conditions, but must not be pressure washed. In case of wash down conditions, it is recommended to cover each labeling head with a plastic tarp.

For the overall cleaning, it is recommended to use compressed air and clean, damp wipes.

Always turn off the system before proceeding with cleaning and maintenance.

The following section explains the preventive maintenance for each section

After every 100 hours of operation, a visual inspection of the system should be done and where it is necessary, lubricate and cleaning should be performed.



CAUTION

WEAR PROTECTIVE EYEWEAR when performing any maintenance on this equipment.



CAUTION

To reduce risk of fire, electrocution or other personal Injury when operating or maintaining the labeling head, follow basic safety precaution, including the following:

DO NOT perform any servicing or maintenance with the power ON.

Always disconnect the electrical plug from the wall socket

Make sure that the power is OFF or that the available E-stop buttons have been activated.

LABELING SYSTEM

This labeling system is reliable, versatile and durable. It will operate for years with very light maintenance if it is performed regularly. Most of the maintenance takes only a few minutes and substantially increases the operational life of the system and maintains label placement accuracy.

Not all sections may apply to your equipment.

Daily:	D
Weekly:	W
Monthly	M
Quarterly	Q
Semi-Annually	S

ASSEMBLY TITLE: LABELING HEAD ASSEMBLY

D- Remove glue residue and labels from all rollers and idler. DO NOT use a knife or other tool to scrape the rollers. Adhesive Remover such as Goo-Gone or 3M Adhesive Remover is recommended. DO NOT use an adhesive remover that reacts with plastics or sensor lenses will be damaged.

M- Check for loose idlers and components and tighten as needed.

S – Lubricate all idler rollers shafts using 80w-90w gear lube on the white bearings where they contact the axle.

ASSEMBLY TITLE: UNWIND ASSEMBLY

S- Check and adjust dancer spring. If final spring tension is too soft then replace.

S- Check and inspect band brake. Replace if torn

ASSEMBLY TITLE: REWIND ASSEMBLY

S- Check and inspect friction disc (if applicable), Replace when worn out.

S- Check Kinetrol (if applicable) for leaks, Replace if necessary.

ASSEMBLY TITLE: BRAKE BRUSH ASSEMBLY

S- Reverse brake brush direction

S- Inspect Brake brush when brush body contour no longer viable or bristles are worn down. Replace

ASSEMBLY TITLE: SLOT SENSOR ASSEMBLY

D- Keep the sensor optical area clean from label and glue residue

ASSEMBLY TITLE: SIDE PLATE ASSEMBLY

S- Lubricate all idler rollers shafts using 80w-90w gear lube on the white bearings where they contact the axle.

ASSEMBLY TITLE: PEEL PLATE ASSEMBLY

D- Clean all the parts that may acquire labels or glue residue. DO NOT use a knife or other tool to scrape the rollers. Adhesive removers are recommended.

W- Inspect Teflon tape on peel plate tip. Replace if the steel is exposed.

S – Lubricate all idler rollers shafts 80w-90w gear lube

ASSEMBLY TITLE: DRIVE AND PINCH ROLL ASSEMBLY

D- Remove glue residue and labels from drive roller. DO NOT use a knife or other tool to scrape the rollers. Isopropyl alcohol and adhesive removers are recommended.

W- Clean the knurled roll with a soft brass brush and adhesive remover.

M- Check and inspect drive roll. No play should be present when powered up. If there is a groove the width of the label liner, replace the worn roller.

M – Lubricate knurled roll shafts using 80w-90w gear lube.

S- Inspect and Lubricate, springs and slugs.

ASSEMBLY TITLE: ROLLER/BRUSH IMPRESSER

D- Check the rollers/brushes. They should be free of label flash, glue and debris. This will prevent jamming and web tears.

W- Check the foam rollers. If foam wear is noticeable, replace as necessary.

NOTE: Exercise caution when removing bad labels from foam. Careless removal can result in torn foam which may leave the labeler inoperable until the roller is replaced!

ASSEMBLY TITLE: OPERATOR PANEL

-No maintenance is required for the operator panel

-Occasionally, the keypad may be cleaned with any non-solvent based cleaning solution. Glass cleaner on a clean towel then wipe the membrane.

ASSEMBLY TITLE: ELECTRICAL

W- Check the foam filter for the fan. Clean or replace.

ASSEMBLY TITLE: CONVEYOR

D – Inspect conveyor chain for broken flights of table top chain

W – Inspect conveyor for labels / adhesive and remove as needed

S – Check gearbox oil levels and add as needed.

American Lubricants SHC-90W oil.

ASSEMBLY TITLE: FEEDSCREW

W – Remove glue residue and labels from feed screws

W – Lubricate internal feedscrew drive assembly, with multi-purpose grease.

S – Lubricate grease fittings / chains / bearings with quality multi-purpose grease – as needed

ASSEMBLY TITLE: VERTICAL ROLLER

W – Remove labels from rollers with adhesive remover / cleaner

W – Lubricate chains with food grade grease.

ASSEMBLY TITLE: EJECT STATION

D – Clean all parts that have acquired label or glue residue

ASSEMBLY TITLE: INFEEED / OUTFEED BANK SENSOR

W – Clean and glue residue or labels off sensor and/or reflectors

ASSEMBLY TITLE: SLEEVE

M – Drive rollers – Inspect for wear and clean with a citrus based adhesive removal

M – Inspect tension belts for cutter blade and cutter assembly for wear. Replace as needed.

M – Inspect cutter blades and bearings for wear. Replace as needed

M – Inspect perforation blades / bearings for wear and free of debris. Replace as needed.

S- Check, inspect, and grease all lead screws (threaded rods)

S – Inspect mandrel and bearings for wear. Ensure they spin freely
Replace as needed.

NOTES:

GENERAL PURPOSE FEEDSCREW LUBRICATION GUIDE

During your weekly maintenance of your Quadrel Labeling Systems equipment follow the steps below to ensure proper lubrication of the internal drive system for your feedscrew assembly.



Step 1 – Your dual feedscrews are connected inside the conveyor with a spline shaft assembly. First remove the chain so you have easy access to the this.



Step 2 – Open your feedscrews to your largest product. This will expose the spline assembly shaft that you will be applying the multi-purpose grease to.



Step 3 – Apply multi-purpose grease to the now exposed spline shaft assembly. Ensure to apply multi-purpose grease all the way around the spline shaft– Top, bottom and sides

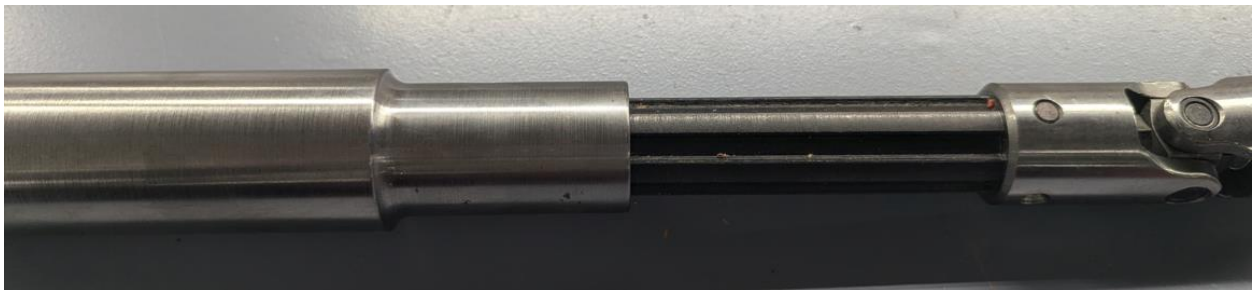

Step 4 – Slowly move the feedscrews in and out to so the grease can spread evenly over the length of entire spline shaft assembly.

Step 5 – Reconnect conveyor chain

Setup procedure for Powered rewind using MGC403-11-00MD drive

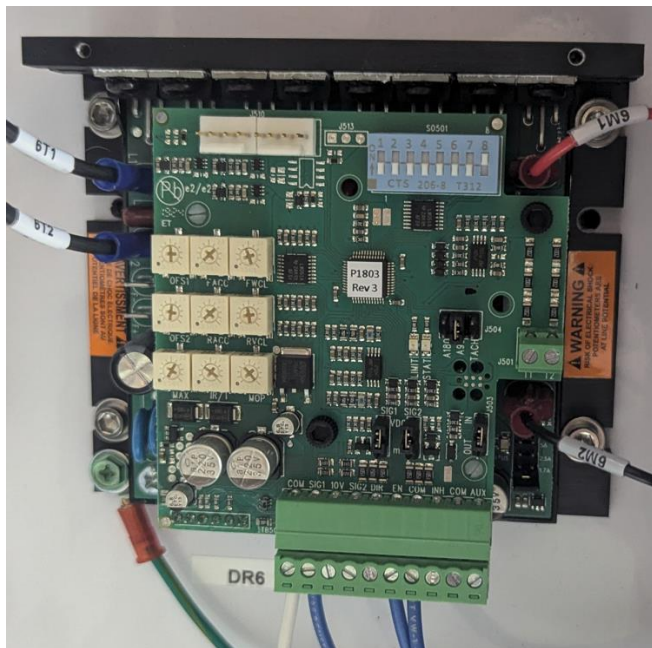

Upon receiving drive set the following **BEFORE** installing in the machine.

1. Dip switches - set all switches to the off position. This is the Light blue row of switches shown in the image below

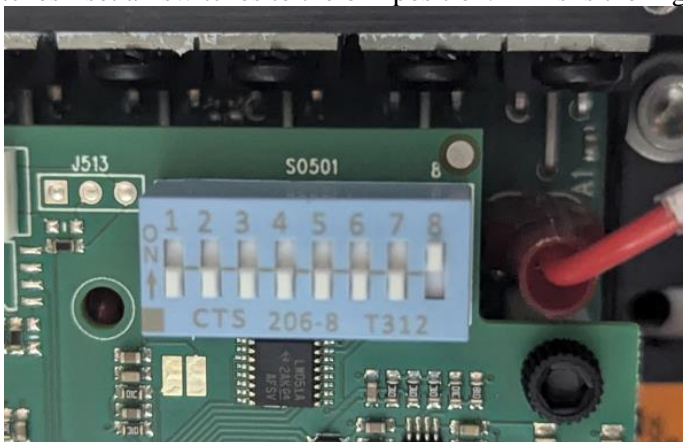

- a.
2. Set Jumpers on drive based on electrical schematic for your machine
 - a. SIG1 – VDC
 - b. SIG2 – VDC
 - c. J504 – A90
 - d. AMP CURRENT – 1.7A – This located near the 10 pin green connector that

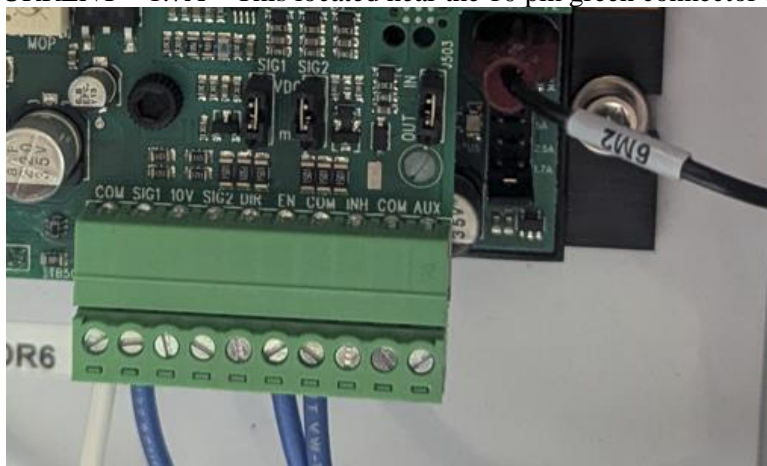

i.

3. Using a small flat blade / Slot screwdriver adjust the following pots as indicated in the image below:

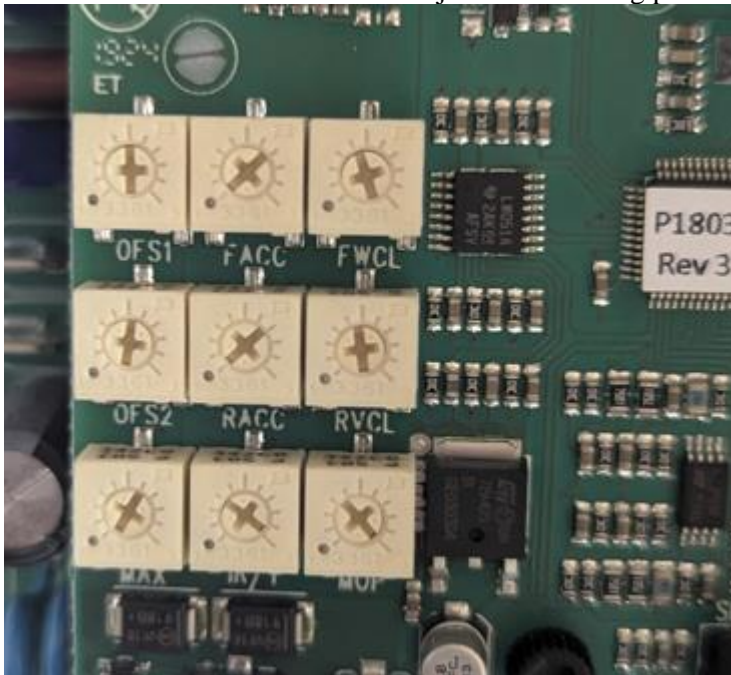

- a.
- i. Top row **OFS1** – WILL BE ADJUSTED AT LATER STEP
 - ii. Top row – **FACC** - turn counter clockwise until it stops.
 - iii. Top row **FWCL** – set to half way point – midpoint
 - iv. Middle row - **OFS2** – turn counter clockwise until it stops. This turns the pot OFF
 - v. Middle row – **RACC** - turn counter clockwise until it stops
 - vi. Middle row – **RVCL** – set to half way point – midpoint
 - vii. Bottom row – **MAX** – Set to 3/4 point
 - viii. Bottom row – **Leave other 2 pots at factory setting – DO NOT ADJUST**

4. Install drive in machine then proceed to next steps

5. Set the Cam on the rewind dancer per image below when the dancer arm is at rest. Rest is when the arm is all the way back against the rubber bumper as shown

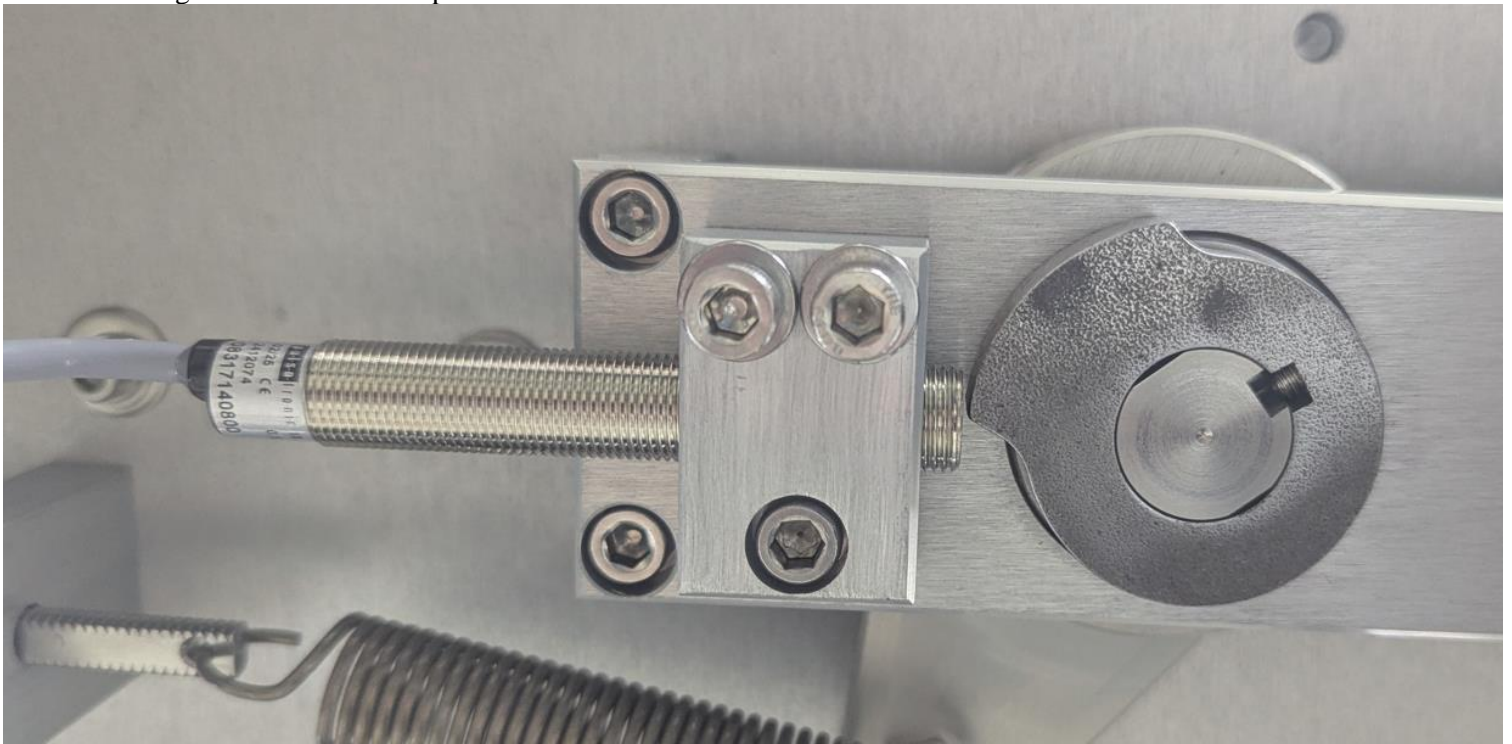



6. On the HMI go to into labeling head service menu. You will be looking at the REWIND PROX VOLTAGE (example below)

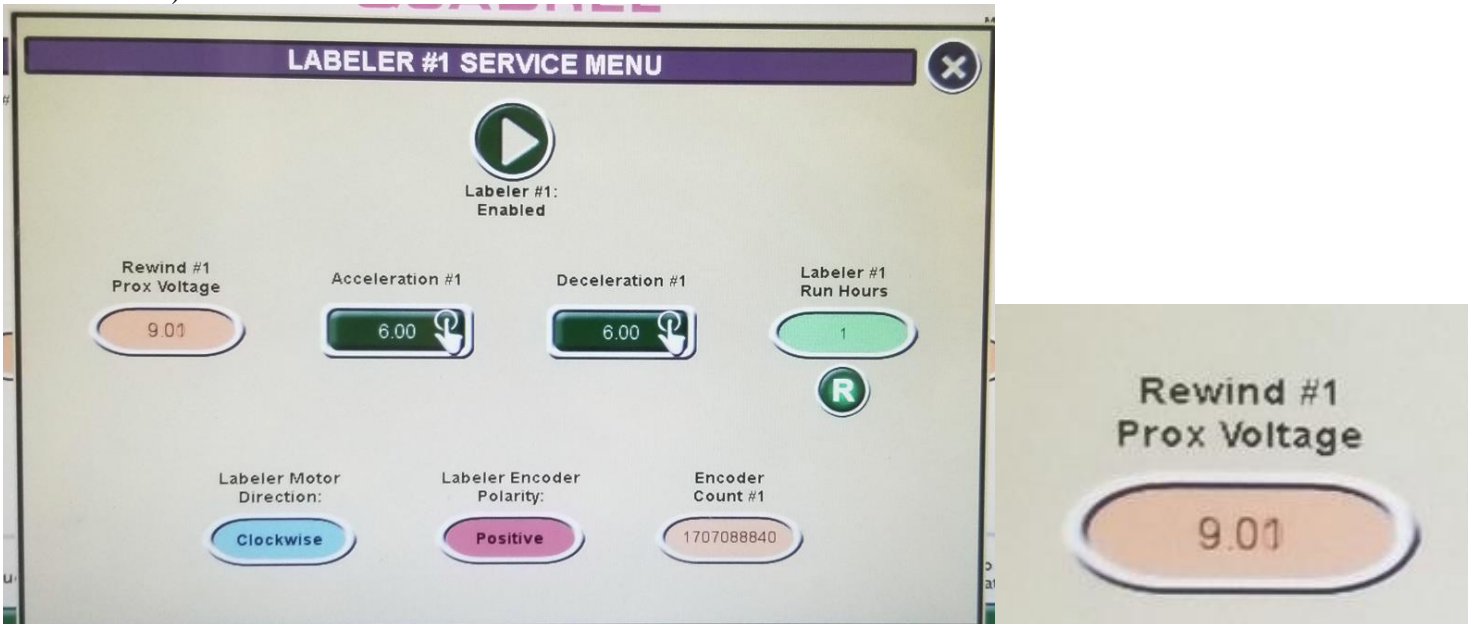

7. Adjust the sensor gap at the cam by loosening the bolt using an allen key so that the sensor can be moved forward or backward. The bolt does NOT touch the sensor. Loosening it opens the clamp so you can adjust.
8. Set the gap so the REWIND PROX VOLTAGE on the HMI reads **.90 it must be under 1 volt.**
 - a. **Retighten screw so the clamp sensor no longer moves**

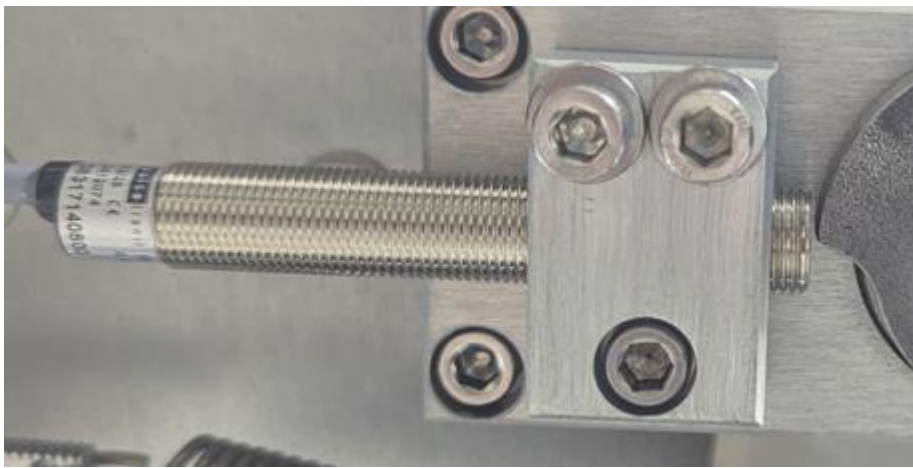

b.

9. Test by moving the rewind dancer arm forward. When doing this you should see the rewind prox voltage on the HMI increase up to 9 volts

a. If you do not see the voltage increase steadily, recheck cam sensor gap in step 7

10. Turn on rewind switch on the back of the labeler. This will engage / turn on the motor.

11. Move the rewind dancer arm forward the rewind hub should start to turn clockwise. It will slow then stop as you move forward. Rewind hub should ALWAYS be turning clockwise. If it moves counter clockwise move to **step 11a**

a. While holding the arm in the position where it started to run counter clockwise, it MUST be running counter clockwise, you will adjust **OFS1** until the rewind hub stops moving.



i.

b. This adjustment may need to be done multiple times until it no longer moves counter clockwise when rewind arm is all the forward and at rest.

9.2 BELTS

Monthly, a visual inspection of the rewind belt and timing belt, to do this depending on the labeling head you may need to remove the bottom cover on the head.

Refer to photos below.

Servo labeling head.

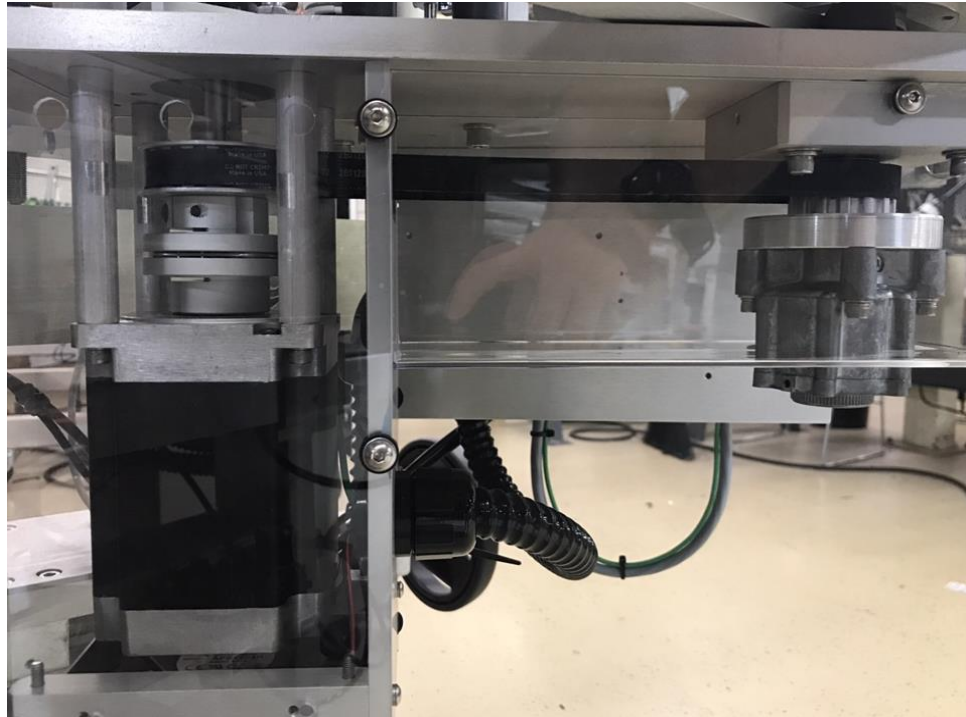

Stepping labeling head.

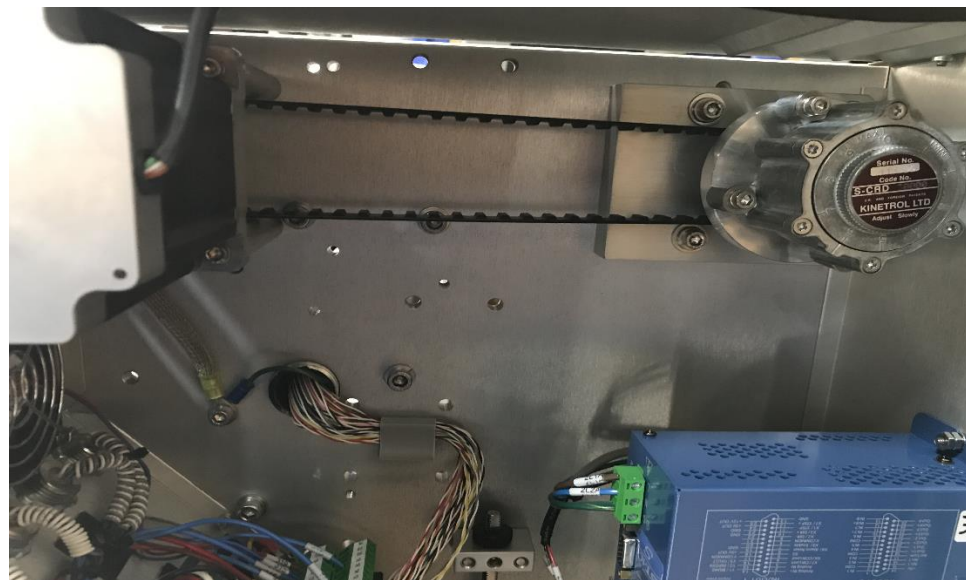

CAUTION

DO NOT ATTEMPT doing this with the equipment under tension (with power on).

The visual inspection should consist of looking for cracks or defects in the belts. If this is the case, change the belts that are defective. Refer to the parts listing in the labeling head section of this manual.

The brake band mechanism requires a monthly visual inspection as well. Also once every 12 months you should consider replacing the belt (it is possible that you may need to change it later or earlier than 12 months depending the usage of the labeling head).

The brake band belt assembly is located at the base of the unwind assembly. See images below for reference.

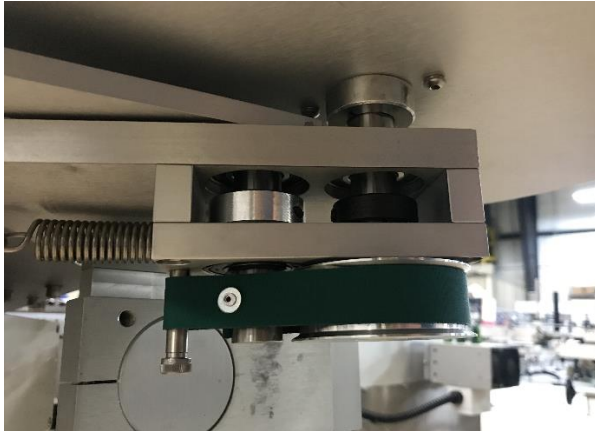

For replacement parts see the unwind assembly drawing for your labeling head in this manual.

9.3 ROLLERS

It is important that your labeler is as clean as possible in its environment in order for it to perform properly. Daily, it is suggested to clean all the rollers including the drive roller (the rubber roller), the pressure shoe and peel plate using a damp cloth with alcohol. Make sure those parts have no glue or labels on it.

Weekly, spray a silicone base lubricant on each end of the plastic bearing.

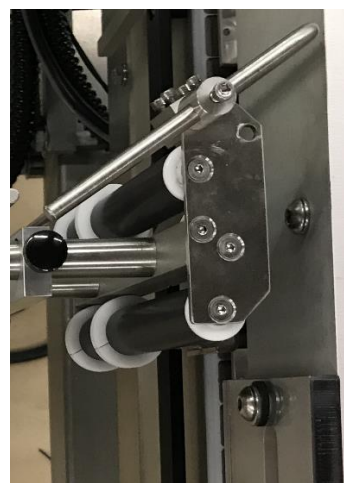
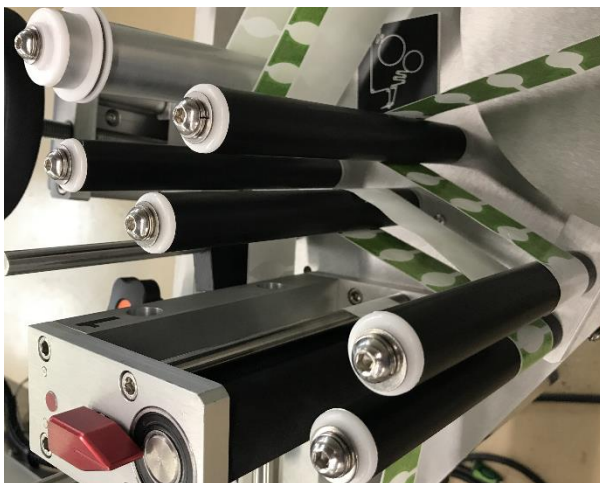

9.4 SENSORS

The sensors all have an electronic eye called a photocell; these must be free of lint or dirt. Since the photocells are generally made with glass or plastic lenses. They naturally attract substances which could easily trigger the sensor, use a cotton swap to gently clean the eye of the sensor as you would any lens, in a circular motion.

9.5 CONVEYOR

Always keep the belt or (chain) clean. To clean it simply use compressed air with an osha approved nozzle and/or damp wipes. If necessary, a soft cleaning agent can be used.

9.5.1 CLEANING

To clean the under carriage portion of the conveyor, simply remove the belt using an punch or similar tool and hammer to tap out the retaining belt link pin. (see images below, the chain has an orientation to the pins, you must tap it out from the narrow diameter) Clean the desired portion with a damp cloth and replace the pin to the belt. The pin will be tapped in the opposite side you tapped it out. *You can also lift the chain and wipe under it.

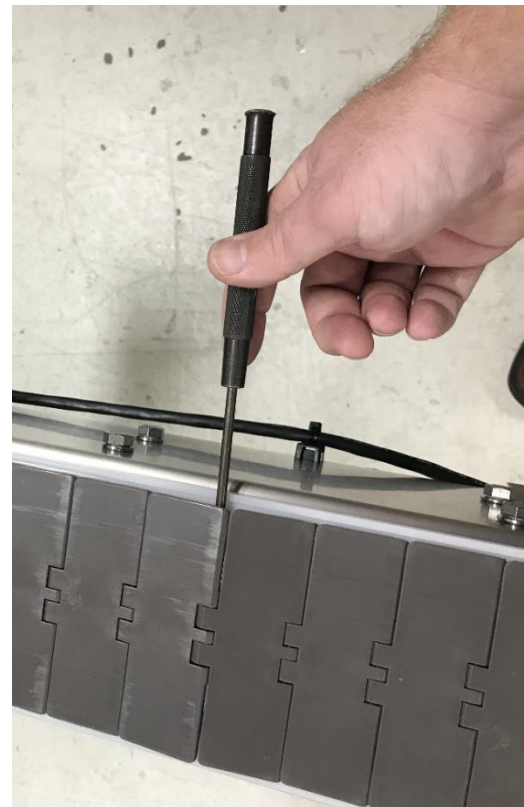
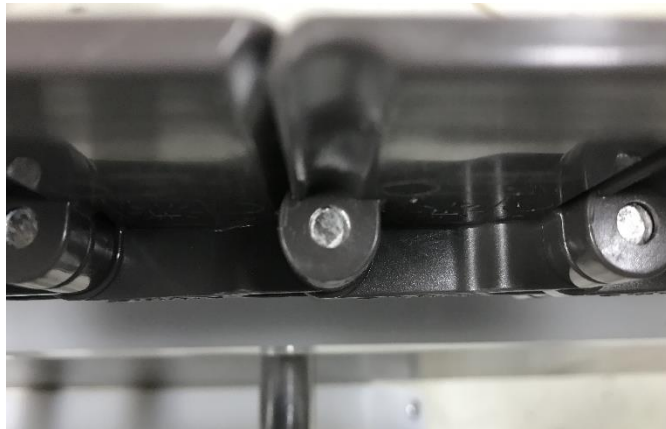

10 CLEARING A JAM

In the event a jam occurs on your Quadrel Labeler reference the following steps to clear.

1. Press the conveyor stop button or the emergency stop if you are unable to reach the stop button.
2. Clear the jam manually in the affected area of the equipment where jam is located
3. Once jam is cleared reenergize the estop, if pressed, and press the reset button (where applicable) to clear faults.
4. Put equipment back into "run" and press start to turn the system back online to continue labeling

11 WARRANTY

The standard warranty period for Quadrel equipment is 12 months following invoicing. The warranty covers all parts with consideration taken towards reasonable use and normal wear and tear. Not covered by warranty are parts that have a limited wear factor, any required labor by Quadrel. Prior to return to Quadrel, parts must be verified defective.

Return of defective parts

To return a defective part, you will need to get an RMA number from Quadrel. All RMA's are issued through our parts department. Please specify the serial number of the equipment, the client's name, address, phone number, contact name and the nature of the problem. To get a replacement part, a purchase order is required. You will be billed for the new part and credited for the defective part after return and evaluation. If the part is determined to be defective due to improper use, no credit will be issued.

Appropriate Use of Equipment

The equipment supplied to the end user by Quadrel are to be used for the sole purpose for which they were intended and must follow Quadrel's specifications on usage as well as appropriate functions. Quadrel will not assume any responsibility for any inappropriate use or modifications to the said equipment other than for the use it was initially built for. The warranty will cease to apply forthwith, in Quadrel's opinion, the equipment has been used abnormally or in an abusive manner, if it has not been properly maintained, if it has not been carried on a truck equipped with an air-ride suspension when required by Quadrel or if it has been used, or maintained contrary to the owners manual provided by Quadrel.

Responsibility Limits

The solution put forth has been prepared with the information that has been provided to Quadrel by the end user. Subsequently, Quadrel cannot assume any responsibility for the exactitude, precision, and the validity of the information which was supplied. Moreover, Quadrel cannot be responsible for (a) any damages, direct or indirect, secondary, or

accessory, including without limitations, the loss of profit, workflow interruption, loss of production, loss of profits and other; (b) any and all damages claimed against the end user by a third party; (c) any or all damages caused to the property of end user or any other third party; (d) any or all resulting in an act from the end user or third party, major force, or act of god, unforeseen cause, or event.

With all reservation, in the eventuality where the responsibility is that of Quadrel relative to any defect of quality of said equipment or proposed solution Quadrel would be able to accept the responsibility, to its entire discretion, with the replacement of part of the said equipment or solution. By a compatible or identical equipment or solution or by a reimbursement of value agreed upon. In no case can Quadrel's responsibility exceed the total monetary sums received for the said defective equipment or solution.