

QUADREL

LABELING SYSTEMS

Operating & Maintenance
Manual
For

WARREN OIL COMPANY, LLC

ECONOLINE FRONT/BACK

Automatic Labeling System

Labeler Model #: Q120 STEPPER
Serial #: 84271-100

QUADREL LABELING SYSTEMS
7670 Jenther Drive
Mentor, Ohio 44060
440.602.4700

customerservice@quadrel.com
parts@quadrel.com

TERMS AND CONDITIONS OF SALE

QUADREL, INC

D/B/A Quadrel Labeling Systems Hereinafter Referred to as Quadrel

PERFORMANCE GUARANTEE:

If the surface of the product to be labeled is free from contamination so as to ensure proper label adhesion, the labels are manufactured in accordance with label specifications provided and the equipment is operated and maintained in accordance with the instructions contained in the Quadrel manual (two copies of the manual will be supplied by Quadrel with the labeling system; one printed copy, and one electronic copy). Quadrel guarantees the EQUIPMENT to perform after installation as stated.

1. Provided a sufficient amount of products are presented to the labeling system.
2. Dimensional inconsistency from one like product to be labeled to the other may result in additional label placement inaccuracy in direct relationship to the product inconsistency.
3. Slitting inconsistency within a given roll of labels or from one like roll to another may result in additional label placement inaccuracy in direct relationship to the slitting inconsistency.
4. If the Quadrel labeling system proposed herein does not include physical control of the product during label application, additional placement inaccuracy can occur in direct relationship to the product control inconsistency.
5. Label Placement Accuracy: Within Sigma 2 (approximately 95.5%) to be normal.

In the event of the failure if the Quadrel system to meet customer's specifications, as quoted by Quadrel or subsequently agreed to by Quadrel. Quadrel upon written notice from buyer shall, at its option, repair the system, or refund the purchase price upon return of the system. The warranty provided in this article and the obligations and liabilities of Quadrel thereunder are exclusive and in lieu of, and buyer hereby waived, other remedies warranties, guarantees or liabilities, express or implied arising by law or otherwise (including without limitation, any obligations of Quadrel with respect to fitness for a particular purpose, merchantability, specific performance, incidental and consequential damages) whether or not occasioned by Quadrel's negligence. This warranty should not be extended altered or varied except by written instrument signed by Quadrel and buyer.

EXCLUSIVE TERMS OF SALE: The proposal attached hereto or to which these Terms and Conditions of Sale apply (the "Proposal"), together with these Terms and Conditions of sale (collectively, the "Sale Agreement"), constitutes the complete and exclusive statement of the agreement between Quadrel and the purchaser specified in the Proposal ("Purchaser") concerning the equipment and other goods specified in the Proposal (collectively, the "Equipment"), as well as any and all services specified in the Proposal (collectively, the "Services"), and supersedes all prior contemporaneous agreements, representations and/or communications, either oral or written, between Quadrel and Purchaser or any representative such as parties with the respect to the subject matter of the Sale Agreement. No change to the Sale Agreement or waiver of any provision thereof will be binding on Quadrel unless made in writing and signed off by and authorized officer of Quadrel. Acceptance of the Equipment, in whole or part, or other express or implied assent by Purchaser to the terms hereof shall constitute Purchaser's agreement to the terms of the Sale Agreement. Acceptance of any purchase order or other document of Purchaser by Quadrel is expressly made conditional on the Purchaser's assent to the Sale Agreement. ANY ATTEMPTED MEMORIALIZATION OF THIS SALE BY A PURCHASE ORDER OR OTHER DOCUMENT CONTAINING TERMAND CONDITIONS INCOSISTANT WITH OR IN ADDITION TO THE CONDITIONS CONTAINED IN THE SALE AGREEMENT SHALL NOT BE BINDING UPON QUADREL AND QUADREL HEREBY EXPRESSLY OBJECTS TO AND REJECTS THE SAME.

GENERAL WARRANTY (EXCLUDES TABLETOP LABELERS)

Time from date of shipment	Covered Expenses
Up to 90 Days	All Parts , service time, living and travel expenses
UP to 12 Months	All parts

THE WARRANTIES PROVIDED ABOVE ARE IN LIEU OF ANY AND ALL OTHER WARRANTIES AND LIABILITIES, EXPRESSED OR IMPLIED, INCLUDING BUT NOT LIMITED TO ANY WARRANTIES OF MERCHANTABILITY OR FITNESS FOR ANY PARTICULAR PURPOSE. NO OTHER WARRANTIES ARE OFFERED BY QUADREL WITH RESPECT TO THE EQUIPMENT OR SERVICES AND QUADREL HAS NOT AUTHORIZED ANY EMPLOYEE OR AGENT TO OFFER ANY WARRANTIES EXCEPT THOSE PROVIDED ABOVE. PURCHASER AND QUADREL EXPRESSLY AGREE THAT THE WARRANTIES PROVIDED ABOVE SHALL SERVE AS PURCHASER'S SOLE AND EXCLUSIVE REMEDY WITH RESPECT TO THE EQUIPMENT AND SERVICES.

PURCHASER REQUIREMENTS. Purchaser must provide Quadrel descriptions and specifications of all labels and items to be labeled, including, without limitation, label material, product and label dimensions, and any other items required by Quadrel. Further, purchaser shall furnish Quadrel one (1) production size roll of each label and 100 samples of each item to be labeled for testing purposes. **Quadrel shall have no liability (whether under its Limited One-Year Warranty or otherwise) for labeling performance on labels or items to be labeled:**

- (a) Which were not specified or sufficiently described in the Proposal: or**
- (b) With respect to which Purchaser fails to provide Quadrel the samples specified herein, even if such labels or items to be labeled were specified in the Proposal. Further, Quadrel shall have no liability for delays caused by Purchaser's failure to furnish samples as specified herein.**

LIMITATION OF WARRANTIES. Quadrel shall have no obligation to honor its warranties and shall have no liability with respect to defective Equipment if:

- (a) The Equipment has been modified, altered, damaged, abused or used for any other than those purposes intended by Quadrel.
- (b) The Equipment has been changed without prior written consent from Quadrel.
- (c) The equipment has not been operated and maintained in accordance with generally accepted commercial practices for similar equipment and Quadrel's specifications and instructions, as published in the Quadrel manual.
- (d) The surface if the product to be labeled is not clean and free of contamination, including, but not limited to, mold release agents, condensation, dirt and oil.
- (e) Labels are not manufactured in accordance with label specifications provided by Quadrel, or are not from defects such as cracked edges, deep die strikes, *etc.*
- (f) Labels and items to be labeled are not set forth in the Proposal.
- (g) Samples of all products and labels were not provided to Quadrel for testing prior to Equipment shipment as required under "Purchaser Requirements" outlined above.
- (h) There is dimensional inconsistency from one like roll of labels to another.
- (i) *The Equipment does NOT include physical control of the product.*

LIMITATION OF REMEDIES. All warranty claims shall be subject to review and approval by Quadrel. Quadrel's obligation to honor warranties is in all cases limited to, at Quadrel's sole option:

- (a) Repair of defective Equipment or components: or
- (b) Providing a cash refund or credit, after Purchaser has returned Equipment to Quadrel.

Where warranty service is to be provided at the Quadrel facility, Purchaser shall return Equipment claimed to be defective to Quadrel, freight prepaid, for review. No Equipment shall be returned to Quadrel, whether for inspection, repair, refund, or any other reason, without prior return authorization from Quadrel. Quadrel may charge Purchaser cost resulting from testing, handling and disposition of Equipment claimed to be defective by Purchaser which is found by Quadrel to conform to Quadrel's warranties.

LIMITATION OF LIABILITY. QUADREL SHALL HAVE NO LIABILITY FOR ANY CONSEQUENTIAL, INCIDENTAL, PUNITIVE OR SPECIAL DAMAGES BY REASON OF ANY ACT OR OMISSION OR ARISING OUT OF OR IN CONNECTION WITH THE (a) EQUIPMENT OR ITS SALE, DELIVERY, INSTALLATION, MAINTENANCE, OPERATION, OR PERFORMANCE, OR (b) SERVICES. IN NO EVENT SHALL QUADREL'S LIABILITY EXCEED THE PRICE OF THE EQUIPMENT (OR THE PRICE OF THE SERVICES IF A CLAIM IS MADE WITH RESPECT TO THE SERVICES) WITH RESPECT TO WHICH A CLAIM IS MADE REGARDLESS OF WHETHER SUCH CLAIM IS BROUGHT

AT LAS OR IN EQUITY AND REGARDLESS OF WHETHER SUCH CLAIM IS BROUGHT UNDER CONTRACT, BREACH OF WARRANTY, TORT OR ANY OTHER THEORY OF LAW OR EQUITY.

ORDERS:

Orders entered, verbal or written, cannot be cancelled except upon terms that will compensate Quadrel against any and all claims

START-UP SERVICE:

Quadrel will provide, at standard installation rates, the number of normal eight-hour working days for the Quadrel Field Service Technician to start the EQUIPMENT and to train PURCHASER'S operating and maintenance personnel. EQUIPMENT is not uncrated and emplaced in desired location by PURCHSER prior to arrival of Quadrel Field Service Technician, or if the EQUIPMENT cannot be made operational due to non-availability of products, labels, appropriate utilities and/or related production equipment, PURCHASER shall pay Quadrel for additional service time required including travel expenses, if applicable, in accordance with Quadrel's Field Service rates. It is PURCHASER's obligation to schedule the start-up service at a time when PURCHSER'S engineering, maintenance and selected production personnel are available.

SERVICE AFTER INSTALLATION:

Quadrel Field Service Technicians are available to customers who do not maintain their own service departments. This can be handles on a per visit basis. Field Service rates are available on request.

PAYMENT TERMS:

Payment terms are as follows: 50% of purchase with purchase order, 40% of purchase at the time of shipment, 10% of purchase (plus freight charges) due net 30 days. If shipment is delayed beyond 30 days after the EQUIPMENT has been made ready for shipment, and the delay is caused directly or indirectly by the PURCHASER, then the total of the unpaid balance, at option of Quadrel, may become immediately due and payable upon written notice. Payments not paid when due shall thereafter bear monthly service charges at the rate of 1.5% per month on the unpaid balance until paid. If, in Quadrel's opinion, PURCHASER'S financial condition does not justify continuance of production or shipment on the terms of payment specified above, Quadrel may require payments in advance.

FINANCIAL IMPAIRMENT. Quadrel may, at its option, suspend performance if in its opinion the credit of the Purchaser becomes impaired until such time as Quadrel has received full payment, including any general price increases or surcharges, is satisfactory security for deliveries made and is satisfied as to Purchasers credit for future deliveries. Quadrel reserves the right to cancel Purchaser's credit at any time for any reason. In addition, Quadrel reserves the right by written notice to cancel any order or require full or partial payment or adequate assurance of performance from Purchaser without Liability to Quadrel in the event of:

- (a) Purchaser's insolvency
- (b) Filing of a voluntary petition in bankruptcy by Purchaser
- (c) Filing of an involuntary petition in bankruptcy against Purchaser
- (d) Appointment of a receiver or trustee for Purchaser
- (e) Execution by Purchaser of an assignment for the benefit of creditors

TAXES:

The amount of any present or future federal, state, local or other taxes applicable to the sale of EQUIPMENT shall be added to the price and paid by PURCHASER unless PURCHASER provides a valid exemption certificate acceptable to Quadrel and the appropriate tax authority.

GOVERNING LAW AND JURISDICTION. The sale agreement shall be governed and construed in accordance with the domestic laws of the State of Ohio without giving effect to any choice or conflict of law provision or rule that would cause the application of the laws of any jurisdiction other than the State of Ohio. Any legal action, suit or proceeding relating to the Sale Agreement shall be heard and determined exclusively in the United States District Court for the Northern District of Ohio or the Court of Common Pleas of Lake County, Ohio, and each party irrevocably submits to the jurisdiction of either such courts and waives any objection which such party may have to the laying of venue of any such legal action, suit or proceeding in any such court.

The Sale Agreement shall not be governed by the United Nations Convention on the International Sales of Goods. No actions arising out of the sale of Equipment or Services may be brought by either party more than one (1) year after shipment.

RETURNS:

EQUIPMENT sold by Quadrel is returnable only in accordance with the provisions hereof. Before returning of any EQUIPMENT or items thereof, PURCHASER must obtain Quadrel's written return authorization and instructions.

FORCE MAJEURE:

Quadrel shall not be liable for any loss, damage, delay, changes in shipment schedules or failure to deliver due to act of God, accidents, fires, strikes, riots, civil commotion, insurrection, war, the elements, embargoes, failure of carriers, inability to obtain electricity or other type of energy, transportation facilities, raw material, equipment or any problem or any similar or different contingency beyond its reasonable control which would make performance commercially impractical whether or not the contingency is of the same class as those above. Quadrel shall in no event be liable for any consequential damages.

TITLE AND RISK OF LOSS:

Title and risk of loss to EQUIPMENT shall pass to PURCHASER upon delivery by Quadrel to a common carrier, regardless of the freight terms stated or method of payment for transportation charges. Quadrel reserves the right to specify routing of shipments.

ENTIRE AGREEMENT:

This agreement embodies the entire agreement and understanding between the parties, is intended as complete and exclusive statement of terms of the agreement between the parties and supersedes any prior agreements or understandings between the parties relating to the subject matter hereof. PURCHASER acknowledges that Quadrel has not made any representations to PURCHASER other than those which are contained herein. Except as provided in this agreement, no change in or addition to the terms contained herein shall be valid as between the parties unless set forth in writing which is signed by an authorized representative of both parties and which specifically states that it constitutes an amendment to this agreement.

The parties may use their normal commercial forms in connection herewith: however, any such forms shall be used for convenience only and any terms or provisions which may be contained therein inconsistent with or in addition to those contained herein shall have no force or effect whatsoever between parties hereto.

EFFECTIVE:

This proposal is based upon the current cost of labor and materials and shall remain in effect for a period of sixty (60) days from the date hereof unless revoked by Quadrel in writing prior to acceptance.

INDEMNIFICATION:

The purchaser of this product ("Customer") hereby agrees to release, indemnify and hold harmless Quadrel and its agents, assignees and representatives for any and all liabilities, losses, costs, damages and expenses (including attorneys' fees and expenses) arising, directly or indirectly, from any and all manner of claims, demands, actions and proceedings that may be instituted against Quadrel on any grounds.

The Customer agrees to, at the Customer's own expense, promptly defend and continue the defense of any such claim, demands, actions or proceeding that may be brought against Quadrel, provided that Quadrel shall, within thirty (30) days of Quadrel receiving notice thereof, notify the Customer of such claims, demand, action or proceeding.

Quadrel shall at all times retain the right to defend itself and/or to otherwise participate in the defense of any such claim or action, and no settlement or other resolution of any such claims or action shall be finalized without Quadrel's written approval. Any failure by Quadrel to give prompt notice or provide copies of documents or furnish relevant data shall not constitute a defense in whole or in part to any claim by Quadrel against the Customer except to extend that such failure by Quadrel shall result in a material prejudice to the Customer.

The forgoing notwithstanding, if suit shall have been against Quadrel and the Customer shall have failed, after the lapse of a reasonable time after written notice to it of such suit, to take action to defend the same. Quadrel shall have the sole right to

defend the claim and shall be entitled to charge the customer with the reasonable cost of any such defense, including reasonable attorney's fees, and Quadrel shall have the right, after notifying but without consulting the Customer, to settle or compromise such claim on any terms reasonably provided by Quadrel.

This release and indemnification is and shall be binding upon the Customer, as well as the Customer's respective heirs, subsidiaries, affiliates, successors, assigns, agents and employees. If any provision or provisions of this release and indemnification shall be held to be invalid, illegal or unenforceable for any reason whatsoever, the validity, legality and enforceability of the remaining provisions of this Agreement shall not in any way be affected or impaired thereby. No supplement, modification or amendment of this Agreement shall be binding unless executed in writing by all of the parties hereto.

Any order put on hold or left dormant for any reason for 90 days will be considered cancelled. See Cancellation Policy below.

CANCELLATION POLICY:

In the event of order cancellation, the 50% down payment is non-refundable. Customer may also be responsible for additional charges covering engineering resources expended and committed materials depending upon the custom nature of the project and the point in the order process in which the cancellation occurs.

NOTE. No salesman, representative or agent of Quadrel is authorized to give a guarantee, warranty or make any representation contrary to above.

Please sign and acknowledge acceptance to these terms and conditions _____ Date _____

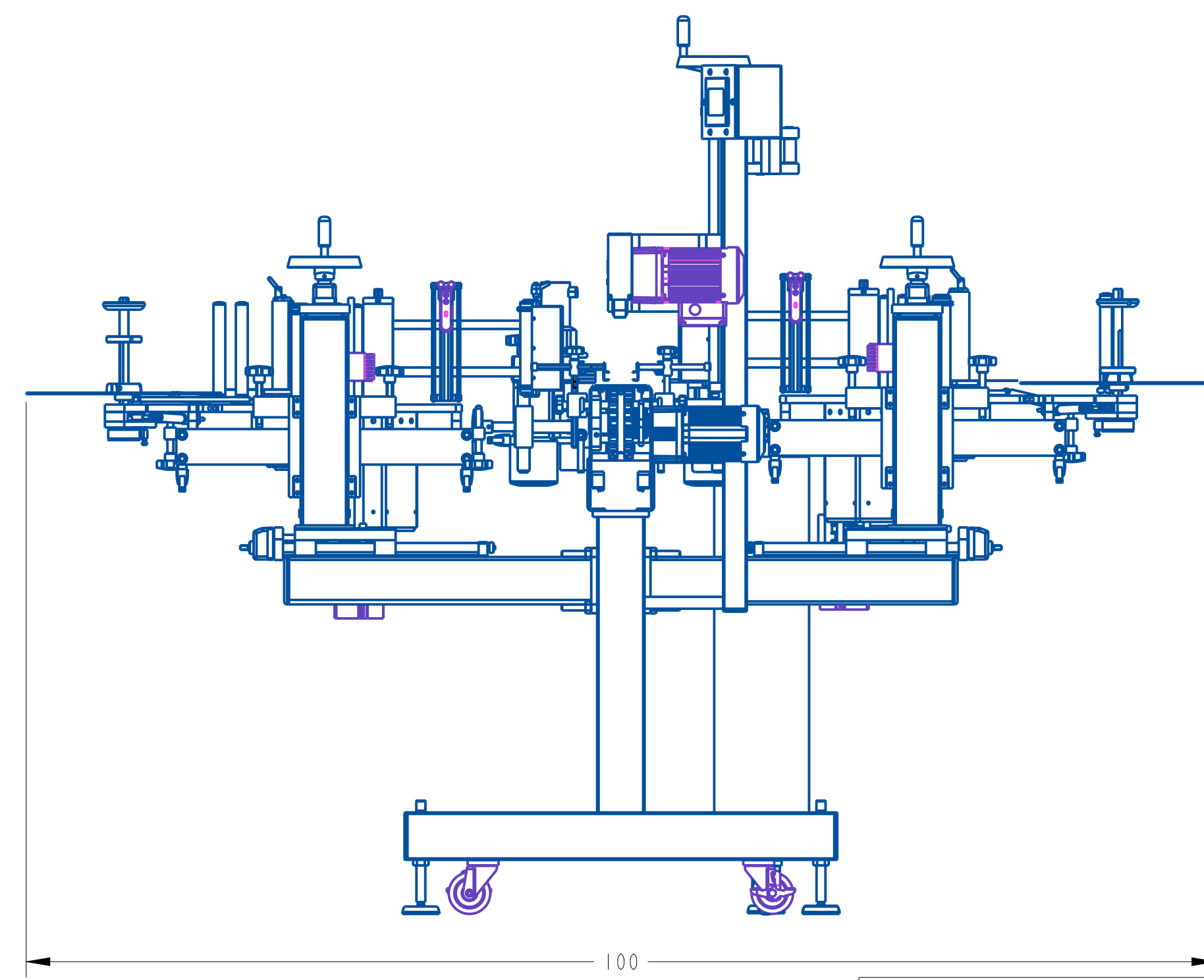
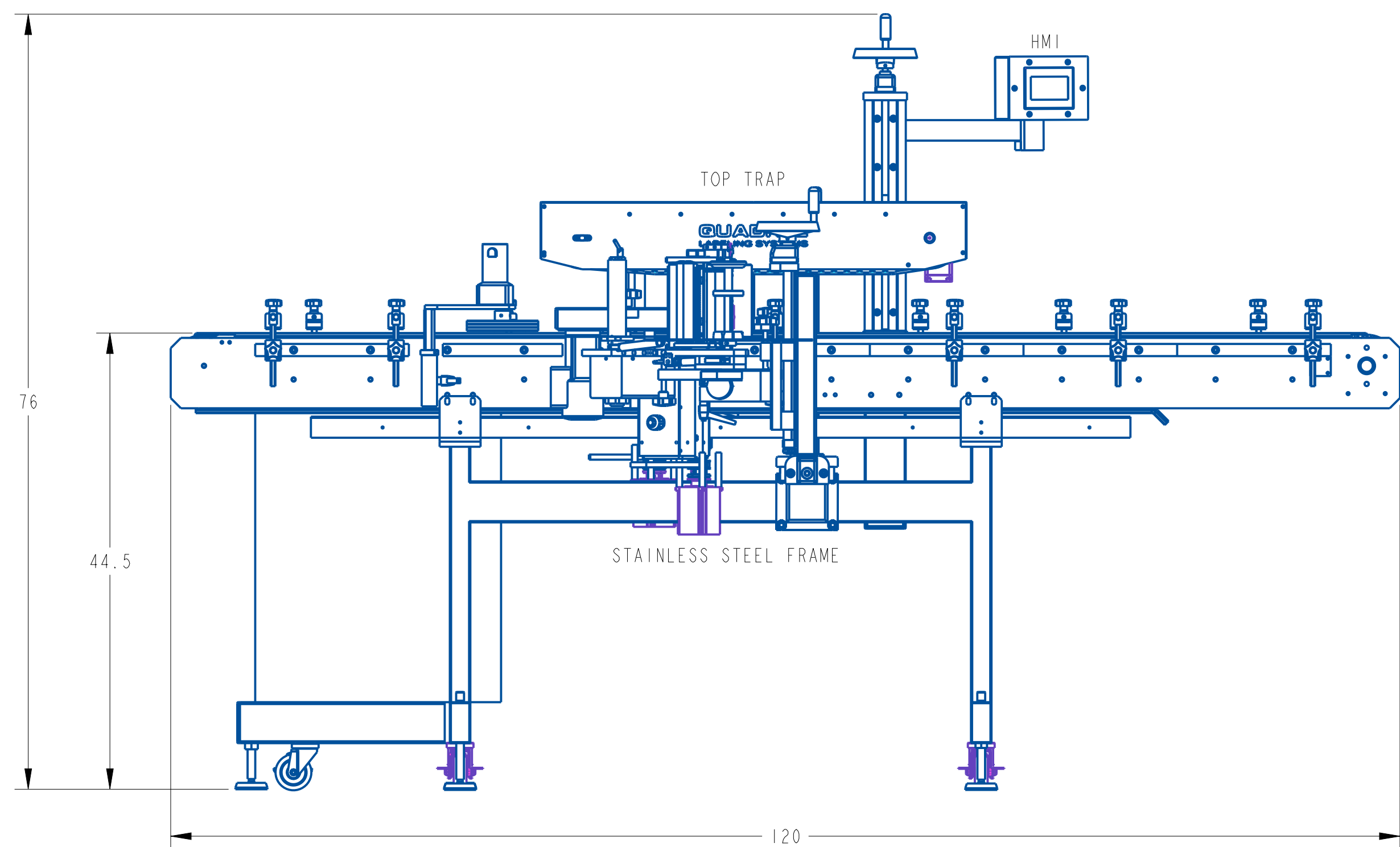
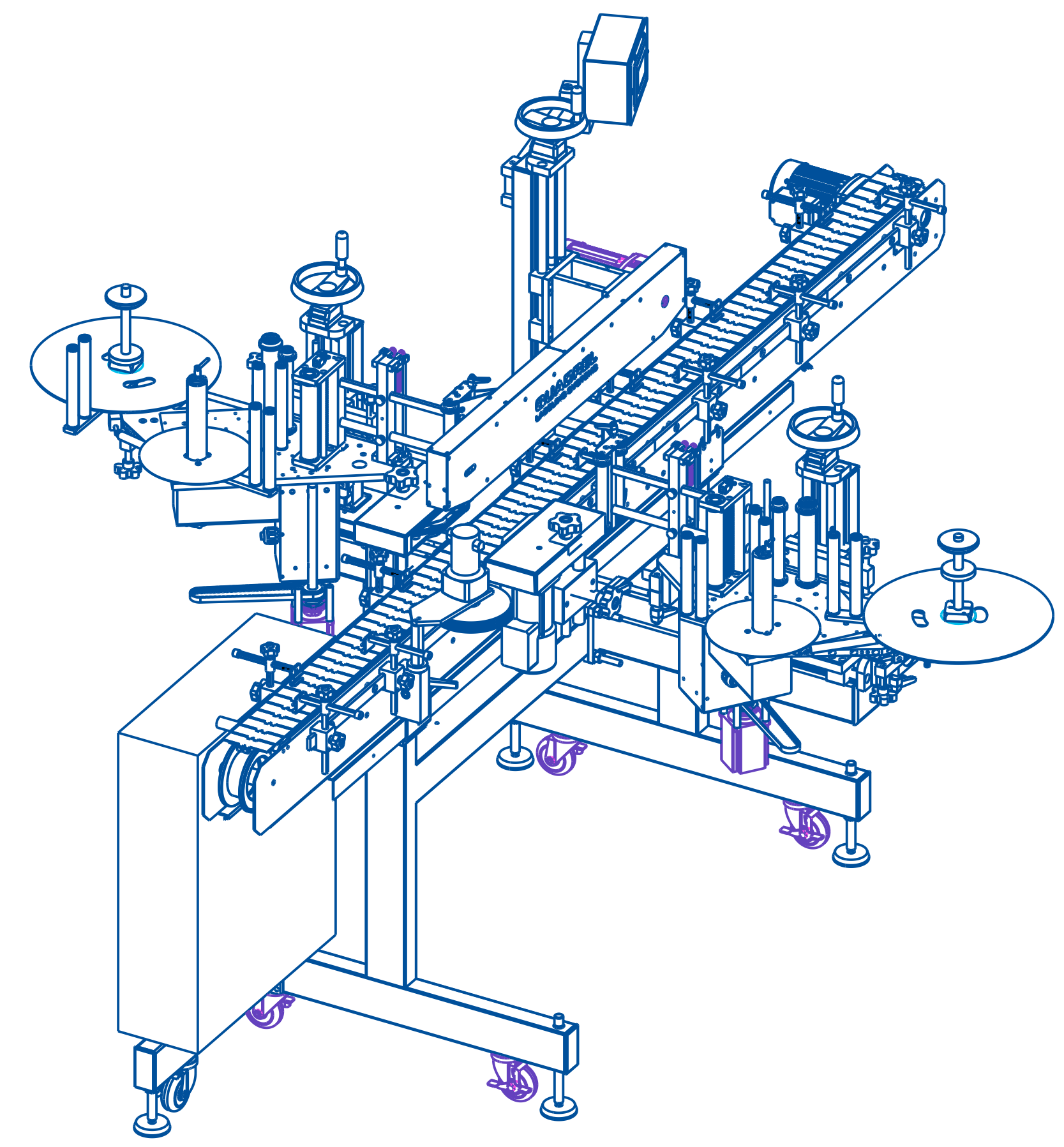
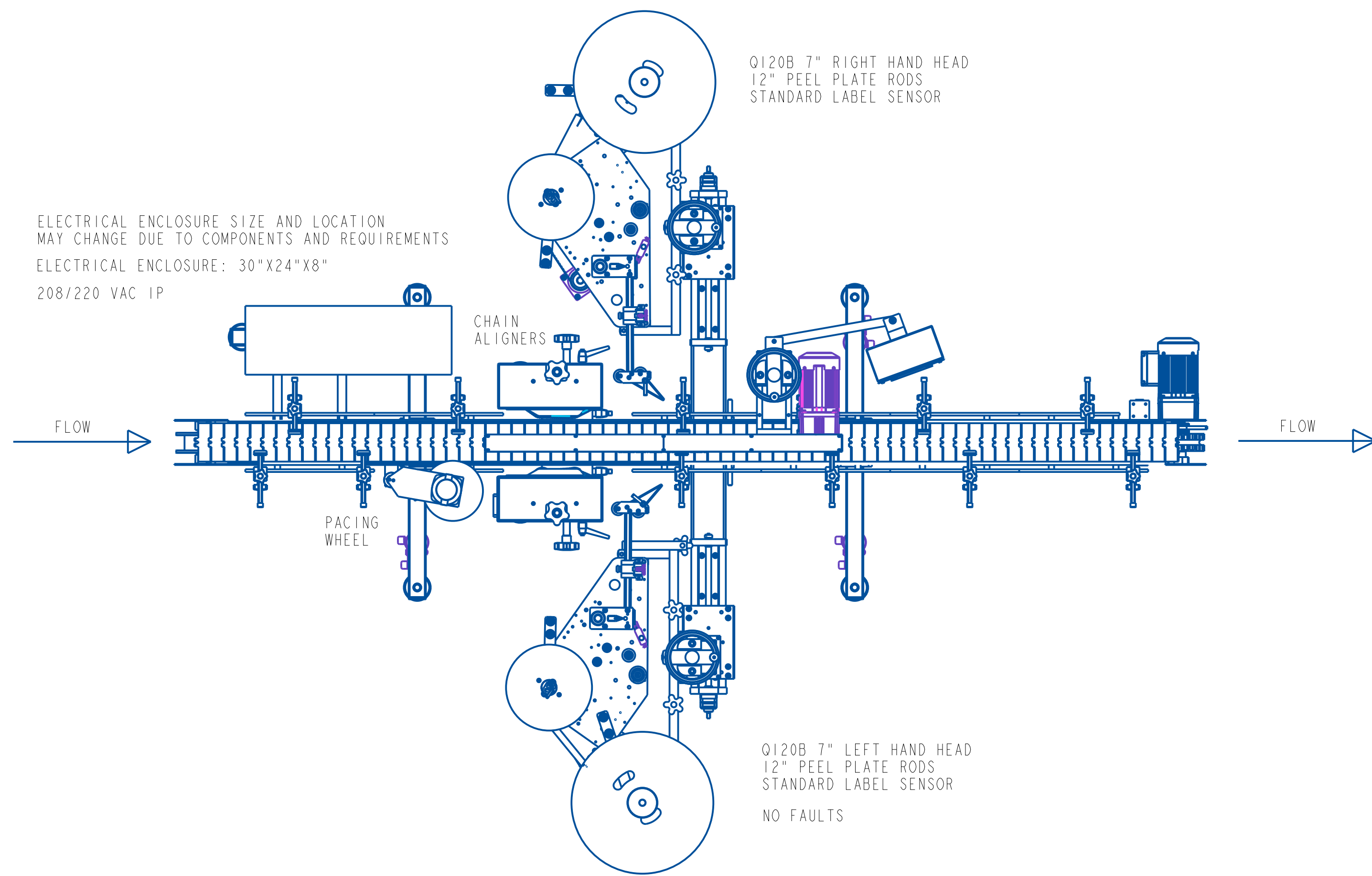

REV	DATE	DESCRIPTION	BY
B	Feb-13-26	HEIGHT WAS 34"	RDL
A	Feb-10-26	NEW DRAWING	RDL

THIS IS A PRO-ENGINEER DOCUMENT AND MAY NOT BE MODIFIED MANUALLY

QUADREL LABELING SYSTEMS
7670 JENTHER DRIVE
MENTOR, OHIO 44060
(440) 602-4700

SCALE: 3/32
DATE: Feb-10-26
DRW BY: RDL
CHK BY:
APPR BY:

ECONOLINE Q110 FRONT/BACK LABELING SYSTEM

APPROVAL DRAWING
WARREN OIL COMPANY

84271-100

UNLESS OTHERWISE SPECIFIED
DIMENSIONAL TOLERANCE
X ± .01
XX ± .01
XXX ± .005
ANGLES ± .30°
SURFACE FINISH 125
BREAK ALL EDGES .005/.015
CORNER RADIUS .010/.030
ALL ANGLES ARE 90°

TABLE OF CONTENTS

1	MANUAL PREFACE
2	GENERAL DISCRPTION
3	WARNING/CAUTION SAFETY INSTRUCTION
	3.1.1 SAFETY INTEGRATION
	3.1.2 GENERAL SAFETY INFORMATION
4	INSTALLATION / REASSEMBLY INSTRUCTIONS
5	HMI GUIDE
6	SET UP SHEETS
7	LABELING HEAD
	7.1.1 LABELING HEAD INFORMATION
	7.1.1.1 LOADING AND UNLOADING STOCK ROLL
	7.1.1.2 THREADING DIAGRAMS
	7.1.1.3 LABELER ADJUSTMENTS
	7.1.1.4 FUNCTION, OPERATION, & TROUBLESHOOTING
	7.1.2 SIDE PLATE ASSEMBLY
	7.1.2.1 ASSEMBLY WRITE UP
	7.1.2.2 DRAWING
	7.1.3 UNWIND ASSEMBLY
	7.1.3.1 ASSEMBLY WRITE UP
	7.1.3.2 DRAWING
	7.1.4 IMPRINTER MOUNT – (OPTIONAL)
	7.1.4.1 ASSEMBLY WRITE UP
	7.1.4.2 DRAWING
	7.1.5 PEEL PLATE ASSEMBLY
	7.1.5.1 ASSEMBLY WRITE UP
	7.1.5.2 DRAWING
	7.1.6 BRUSH IMPRESSER ASSEMBLY – (OPTIONAL)
	7.1.6.1 ASSEMBLY WRITE UP
	7.1.6.2 DRAWING
	7.1.7 DRIVE AND PINCH ROLL ASSEMBLY
	7.1.7.1 ASSEMBLY WRITE UP
	7.1.7.2 DRAWING
	7.1.8 STEPPER/SERVO MOTOR DRIVER ASSEMBLY
	7.1.8.1 ASSEMBLY WRITE UP
	7.1.8.2 DRAWING
	7.1.9 REWIND ASSEMBLY
	7.1.9.1 ASSEMBLY WRITE UP

- 7.1.9.2 DRAWING
 - 7.1.10 SLOT SENSOR ASSEMBLY
 - 7.1.10.1 ASSEMBLY WRITE UP
 - 7.1.10.2 DRAWING
- 7.2 LABELING HEAD FAULTS – **(OPTIONAL)**
 - 7.2.1 ASSEMBLY WRITE UP
 - 7.2.2 DRAWING
 - 7.2.3 END OF WEB / BROKEN WEB / LOW LABEL
- 8 MECHANICAL COMPONENTS
 - 8.1.1 FRAME ASSEMBLY
 - 8.1.1.1 ASSEMBLY WRITE UP
 - 8.1.1.2 DRAWING
 - 8.1.2 CONVEYOR ASSEMBLY
 - 8.1.2.1 ASSEMBLY WRITE UP
 - 8.1.2.2 DRAWING
 - 8.1.3 HEAD SUPPORT ASSEMBLY
 - 8.1.3.1 ASSEMBLY WRITE UP
 - 8.1.3.2 DRAWING
 - 8.1.4 PACING WHEEL/BELT ASSEMBLY/FEEDSCRW
 - 8.1.4.1 GENERAL INFORMATION
 - 8.1.4.2 ADJUSTMENTS
 - 8.1.4.3 ASSEMBLY WRITE UP
 - 8.1.4.4 DRAWING
 - 8.1.5 WRAP STATION ASSEMBLY
 - 8.1.5.1 GENERAL INFORMATION
 - 8.1.5.2 ADJUSTMENTS
 - 8.1.5.3 ASSEMBLY WRITE UP
 - 8.1.5.4 DRAWING
 - 8.1.6 BACK UP PLATE ASSEMBLY
 - 8.1.6.1 GENERAL INFORMATION
 - 8.1.6.2 ADJUSTMENTS
 - 8.1.6.3 ASSEMBLY WRITE UP
 - 8.1.6.4 DRAWING
 - 8.1.7 TOP HOLD DOWN ASSEMBLY
 - 8.1.7.1 GENERAL INFORMATION
 - 8.1.7.2 ADJUSTMENTS
 - 8.1.7.3 ASSEMBLY WRITE UP
 - 8.1.7.4 DRAWING
 - 8.1.8 PRODUCT DETECT ASSEMBLY
 - 8.1.8.1 ASSEMBLY WRITE UP
 - 8.1.8.2 DRAWING
 - 8.1.9 CHAIN ALIGNER / HUGGER BELT ASSEMBLY – **(OPTIONAL)**
 - 8.1.9.1 GENERAL INFORMATION
 - 8.1.9.2 ADJUSTMENTS
 - 8.1.9.3 ASSEMBLY WRITE UP

8.1.9.4 DRAWING

8.1.10 ROTARY ACTUATOR SQUEEGEE ASSEMBLY – **(OPTIONAL)**

8.1.10.1 GENERAL INFORMATION

8.1.10.2 ADJUSTMENTS

8.1.10.3 ASSEMBLY WRITE UP

8.1.10.4 DRAWING

8.1.11 STOP GATE ASSEMBLY / BLADDER – **(OPTIONAL)**

8.1.11.1.1 GENERAL INFORMATION

8.1.11.1.2 ADJUSTMENTS

8.1.11.1.3 ASSEMBLY WRITE UP

8.1.11.1.4 DRAWING

8.1.12 INFEED / OUTFEED BANK SENSORS – **(OPTIONAL)**

8.1.12.1.1 GENERAL INFORMATION

8.1.12.1.2 ADJUSTMENTS

8.1.12.1.3 ASSEMBLY WRITE UP

8.1.12.1.4 DRAWING

8.1.13 EJECT STATION ASSEMBLY – **(OPTIONAL)**

8.1.13.1.1 GENERAL INFORMATION

8.1.13.1.2 ADJUSTMENTS

8.1.13.1.3 ASSEMBLY WRITE UP

8.1.13.1.4 DRAWING

9 ELECTRONICS / SCHEMATICS

10 MAINTENANCE

10.1.1 GENERAL INFORMATION

10.1.2 BELTS

10.1.3 ROLLERS

10.1.4 SENSORS

10.1.5 CONVEYOR

10.1.6 CLEANING

10.1.7 WARRANTY



Quadrel Labeling Systems Quality Manual

Quality Statement:

Quadrel Labeling Systems strives to provide our customers with the highest quality labeling/sleeving solutions available on the market. In order to achieve total customer satisfaction, we shall adhere to the following objectives:

100% on-time delivery

zero defects

Value added service and support

Engineered solutions

Employee development and diversity

We will commit to continuously improve each facet of our business operations through implementation of, and compliance of this manual.

A handwritten signature in black ink that reads "C. Wepler".

Chuck Wepler
General Manager / President

1 MANUAL PREFACE

Thank you for choosing Quadrel Labeling Systems. We have designed and manufactured this equipment with the upmost pride and care ensuring you the absolute best quality, maximum versatility and reliability.

This equipment is intended to be used only as described in this document. Quadrel Labeling Systems Inc. cannot be held responsible for the improper use or functioning of non-described functions of this machinery. Liability for any personal injury, loss of production or revenues, or property damage occasioned by the use of this manual in effect maintenance, operation, or repair of the equipment is in no way assumed by Quadrel Labeling Systems Inc. Anyone one using a procedure not recommended by the end user should first completely satisfy himself/herself that personal safety and equipment integrity will not be jeopardized in the method selected.

DO NOT attempt to install, operate, or adjust the labeling system without first reading and understanding the contents of this manual.

Only a trained person is to be permitted to operate this equipment. Training should include instruction in operation under normal conditions and emergency situations. Under no circumstances should an untrained person operate this machine.

This manual will provide operating instructions, parts listing and schematics. The information contained in this manual will help the user in his/her operations, troubleshooting, and maintaining the machine in good operating conditions. Information, illustrations and specifications contained in this manual are based on the latest product information available at the time of this manual release. Quadrel Labeling Systems Inc. reserves the right to alter and substitute information contained herein at any time.

Due to the customization it is also possible that you have received a different variation of this equipment, with several different options. Some pictures used in this manual may not totally reflect your configuration, although the labeling is completely the same.

All rights reserved while every precaution has been taken in the preparation of this manual, Quadrel Labeling Systems Inc. cannot be held responsible for errors, omissions, damages, loss of production, or revenues resulting from the use of the information contain herein.

2 GENERAL DISCRIPTION - ECONOLINE

In-line labeling machines apply labels to a wide variety of container shapes. In addition to conventional cylindrical containers, the in-line labeler can be used with specially contoured, elliptical or flat-sided containers. In-line labelers are manufacturing in a variety of configuration. Diagrams illustrate standard in-line labeler arrangements for different container designs.

The Econoline is a compact and economically priced labeling system. Simple to set-up, operate and maintain available in front/back or wrap configurations. Features include stainless steel construction and microprocessor control with speeds up to 250 products per minute (depending labeling head). This provides electronic synchronization of the labeling process and stores up to 50 label/ product presets. The “no tool” product changeover and modular design makes this inline labeling system ideal for pharmaceutical, cosmetic, automotive, chemical, food, personal care and many other markets.

3 WARNING/CAUTION SAFETY INSTRUCTION

Where safety is dependent upon starting or stopping devices, or both, they are to be kept free of obstructions that could endanger personnel.

The areas around loading and unloading points are to be kept free of obstructions that could endanger personnel. Instruct personnel working on or near this equipment as to the location and operation of pertinent stopping devices.

This equipment is to be used only for the purpose for which it is constructed.

Under no circumstances are the safety characteristics of this equipment to be altered.

Conduct routine inspections and corrective / preventive maintenance measures to ensure that all guards are installed and function properly. Alert personnel to the potential hazards indicated by the safety labels on this equipment.

3.1 SAFETY INTEGRATION

The end user's safety risk assessment will be the guiding document for proper integration of the equipment provided. Consideration of the following guidelines is recommended in order to achieve a safe result:

- Open areas under the equipment are to be guarded by the end user to prevent entry.
- Where conveyor flight lugs or product enters or exits the equipment, proper guarding and interlock are put in place by the end user to ensure mitigation of shear/jam points.
- The end user is responsible for properly guarding drive components on equipment that requires mechanical drive integration.

3.2 GENERAL SAFETY INFORMATION

This Quadrel Labeling System is engineered to feed and apply labels on your products. In designing the device, Quadrel valued personal safety; however we would like to draw your attention to the following safety acknowledgments.

 **WARNING** Hazards or unsafe practices, which **COULD** result in severe personal injury or death.

 **CAUTION** Hazards or unsafe practices, which **COULD** result in minor injury

 **CAUTION** The presence of safety systems in these units does not exempt the operators to act cautiously, avoiding behaviors that could

endanger their health or the equipment. These models are engineered to feed and apply labels on your products. In designing this device, Quadrel valued personal safety; however we would like to draw your attention to the following safety acknowledgments.

- Operators should know the basic operations and setup procedures before operating this equipment.
- Safe operations should be maintained at all times.
- Know the location of E-stops and power switches prior to operating machinery such as this.

 **WARNING**

To reduce risk of fire, electrocution, or other personal injury when operating. Follow basic safety precautions, including the following:

- This equipment must have an operator attending the machine at all times to monitor the operations. **DO NOT** leave this equipment unattended during maintenance or perform any maintenance unless the e-stop condition has been activated or power turned off.
- The electrical power to device is: 220 Volts, SINGLE (1) Phase, 60 Hz, 15 Amps. While installing make sure it's properly configured and connected by a qualified electrical technician.
- **DO NOT** by pass any of the safety circuits or safety features designed into this equipment.



- ALWAYS turn off **power and pneumatics** before performing repairs.
- The doors on all electrical enclosures must be closed. All covers on labeling heads must be on labeling heads. (if applicable)
- This device is built to perform in humid conditions, but must not be pressure washed. Wiping down the device is the recommended cleaning method.



- Do not stand, sit, or allow any personnel to be within reach of the tamp cylinder/ swing arm activation (if so equip).
- Report any malfunctions, or problems with the equipment to qualified maintenance personnel for repair or adjustments that may be required.
- Keep hands clear of moving parts. Do not place hands near labeling head when in operation.

For systems containing conveyors, you must be vigilant with loose clothing or bodily parts as they can get caught in the conveyor's belt or chains as direct injury or death can incur. **DO NOT** use the conveyor as a working platform or walkway.

TUCK IN ANY LOOSE CLOTHING. DO NOT WEAR TIES. PENDANTS, JEWELRY OR ANY OTHER ARTICLE OF CLOTHING OR ACCESSORY THAT MAY GET CAUGHT ON ANY PORTION OF THE SYSTEM.

FOR PROLINE SYSTEMS ONLY

CASTERS WERE IMPLEMENTED FOR EASE OF SHIPPING PURPOSES ONLY. PLEASE USE CAUTION WHEN MOVING PROLINE THROUGH FACILITY. THE PROLINE RECOMMENDED USE: SET IN PLACE/POSITION WITH LEVELING PADS DOWN TO SECURE.

WARNING

- 1. READ AND UNDERSTAND THE OPERATION MANUAL AND ALL SAFETY LABELS BEFORE OPERATING THIS MACHINE.**
- 2. ONLY A TRAINED PERSON IS TO BE PERMITTED TO OPERATE THIS MACHINE. TRAINING SHOULD INCLUDE INSTRUCTION IN OPERATION UNDER NORMAL CONDITIONS AND EMERGENCY SITUATIONS.**
- 3. THIS MACHINE IS TO BE SERVICED ONLY BY TRAINED AND AUTHORIZED PERSONNEL. FOLLOW LOCK-OUT PROCEDURES BEFORE SERVICING.**
- 4. NEVER REACH INTO THE MACHINE FOR ANY REASON UNLESS THE MACHINE IS AT A COMPLETE STOP.**
- 5. NEVER LEAVE THE MACHINE STOPPED IN SUCH A MANNER THAT ANOTHER WORKER CAN START THE MACHINE WHILE YOU ARE WORKING ON OR WITHIN THE MACHINE.**
- 6. NEVER CHANGE OR DEFEAT THE FUNCTION OF ELECTRICAL INTERLOCKS OR OTHER MACHINE "SHUTDOWN" SWITCHES.**
- 7. BEFORE STARTING THIS MACHINE, CHECK THAT: ALL PERSONS ARE CLEAR OF THE MACHINE; NO MAINTENANCE WORK IS BEING PERFORMED ON THE MACHINE, ALL GUARDS ARE IN PLACE.**
- 8. ROUTINE INSPECTIONS AND CORRECTIVE/PREVENTATIVE MAINTENANCE MEASURES ARE TO BE CONDUCTED TO ENSURE THAT ALL GUARDS AND SAFETY FEATURES ARE RETAINED AND FUNCTION PROPERLY.**

Using VFDs On GFCI Devices

By Bill Szatkiewicz, Senior Software Engineer
KB Electronics

for more information, email: info@kbelectronics.net
or visit: www.kbelectronics.com

The National Electrical Code, or NEC, continues to expand protection requirements for safety reasons resulting in an increase in Ground-Fault Circuit-Interrupter (GFCI) outlets being used in more environments. As a result, the Variable Frequency Drives (VFDs) industry is finding more instances of VFDs being powered from GFCIs. VFDs introduce high frequency harmonic content which may cause nuisance tripping on some GFCI devices. This paper is intended to assist anyone that needs to use a VFD on a circuit with GFCI protection. KB Electronics has developed special VFDs suitable for use with most GFCIs*.

* Please contact KB Electronics with information regarding your specific GFCI.

What is a VFD?

A VFD (also termed adjustable frequency drive, variable speed drive, AC drive, adjustable speed drive, micro drive, motor control, or inverter drive) is a power conversion device that will accept normal fixed branch circuit voltage of (115V or 230V) and frequency (50 Hz or 60 Hz) and allow the operator to control the speed of an induction motor (AC Motor) by varying the output voltage and frequency. A simplistic version of a typical VFD system is shown in Figure-1.

In addition to operator controllability, the VFD with soft start/stop features offers extended equipment life, increased performance, reduced maintenance, protection from excessive currents and voltages, as well as energy savings.

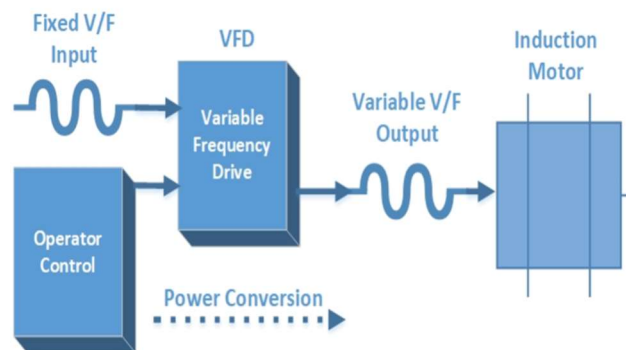

Figure-1: Typical VFD System

What is a GFCI?

A GFCI (shown in Figure-2) is a circuit breaker device which is designed to protect people from hazardous shock or electrocution by shutting off an electric power circuit when it detects current flowing in a way that it is not meant to, such as through water or a person.



Figure-2: Typical GFCI Outlet

The GFCI is intended to protect people from electrical shock, therefore, it is completely different from a fuse in the sense that it needs to shut off the electric power circuit at a low current, typically no more than 5 mA, in a quick amount of time (less than 1/10 of a second).

The GFCI does this by measuring and comparing the amount of current flowing in the ungrounded (hot) and grounded (neutral) conductors of the circuit. If the GFCI detects an imbalance in the circuit, it immediately shuts off the circuit.

Why Nuisance Trips Occur with Standard VFDs

Standard VFDs, when powered from GFCI outlets, can cause the GFCI to trip due to the leakage currents generated from the high switching frequency of the VFD's power devices and the harmonics associated with them. These high frequency leakage currents are not at the base frequency of the drive output which is normally 50 Hz or 60 Hz. These high frequency leakage currents, typically greater than 4 kHz, may cause the GFCI to trip because the GFCI is designed to work with 50 Hz or 60 Hz frequency inputs, not this higher value.

The high switching frequency of the VFD's power devices induce more capacitive-coupled currents, since a capacitor approximates a short circuit at high frequencies. This creates common-mode noise, referred to as leakage current, which travels through ground and can cause the GFCI to trip. The path to ground is made through the motor bearings or auxiliary equipment bearings.

In addition to the high switching frequency of the drive, there can be many other contributing factors which cause the GFCI to trip. Some drives have built-in filters which couple additional leakage current to earth ground. Other drives use external filters and replacing them with a low leakage filter may help.

One way to help determine if the GFCI tripping is occurring from the input filter or the VFD output is to remove either the input filter or the motor and observe if the GFCI still trips. For example, if the input filter is easily removed and doing so

prevents the GFCI from tripping, the source of the leakage currents tripping the GFCI was largely from the input filter.

Another method is to disconnect the motor. If doing so prevents the GFCI from tripping the contributing source of leakage current is most likely from the output stage of the VFD. However, most often than not, the GFCI is tripping from a combination of the two and improvements on both the input and output will help.

Long motor power cables can also create noise spikes. These long leads add more capacitance which increases noise spikes from the fast switching power devices of the VFD. Use a VFD rated cable with the shortest leads possible when connecting the motor power cables. A choke on the VFD's motor outputs may help reduce noise spikes.

In addition, ensure that motor cables are properly shielded, sized, routed, terminated, and grounded at both the motor and drive.

KB's GFCI Solution

KB's engineering team has studied VFDs powered from a variety of GFCI devices. A solution has been created which considers all contributing factors to get a best-case scenario that successfully works with most GFCIs.

KB investigated switching frequencies and developed custom switching frequency algorithms to reduce audible noise and leakage currents. High frequency noise spikes and ringing were reduced by modifying our proprietary power circuits for optimal results. In addition, output chokes, low leakage filters, and shielded cable were introduced, if needed, to find a GFCI solution.

Conclusion

KB has had great success providing VFDs that work with GFCIs for numerous original equipment manufacturers (OEMs). KB offers a full range of motor controls (shown in Figure-3) which can be customized to work with GFCIs. Let KB Electronics provide a solution for you.



Figure-3: VFDs Available from KB Electronics

Unboxing & Installation of your Quadrel Labeling Systems Machine

This section of your manual is aimed towards making the transition from Shipping Crate to Assembly line less Dramatic. If you have scheduled an install with one of our Professional Technicians the set-up of your machine will be a breeze. If not your manual as all of the information needed to get you going. In this section there may be some equipment shown that does not apply to the machine you purchased.

NOTE This is general instruction for all equipment (your equipment may vary slightly).

Let's get started...

First things first, check your crate/box/machine for damage. If there is damage please note the exception and contact Quadrel immediately. Any extra boxes or pallets will be either in your crate or tethered to the crate or pallet. Once you have inspected your shipment you can open the crate. Check packing slip Bill of lading against boxes received. Notify Quadrel of any discrepancies.



Carefully remove all banding on the legs, misc. boxes and assemblies in the crate or on the pallet. If your machine is



wrapped in bubble wrap or plastic wrap go ahead and carefully cut and remove that as well. Ensure you are wearing the appropriate safety gear when removing your machine from the crate.



Ensure all plastic wrap is removed from the assembly you are removing the support from before removing the support.

Remove the supports under your labeling heads, wrap station, top trap, HMI, Pacing wheel or belt. See images for various supported assemblies.

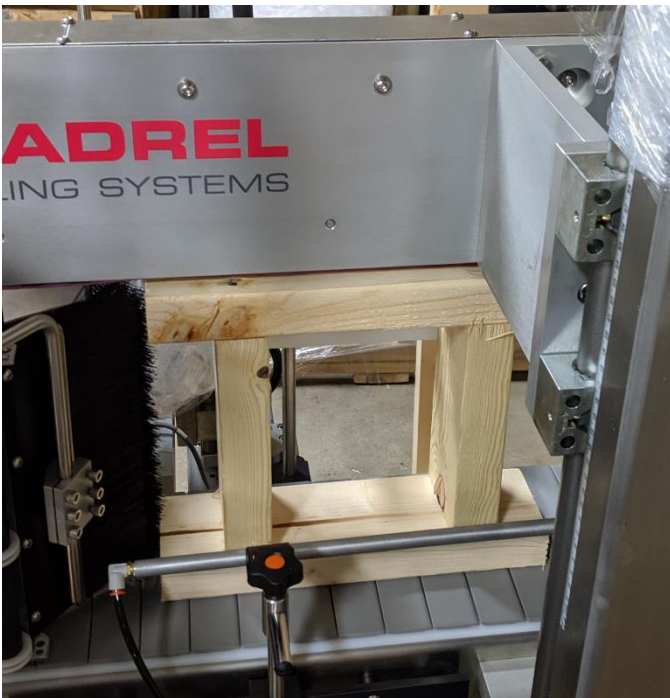

Most assemblies supported have a tool-less vertical adjustment using a knob or hand wheel.

The hand wheel may be wrapped to the assembly to prevent damage.

Remove the hand wheel from the wrap, then fasten the hand wheel to the square end on the lead screw using a 3/32 "L" handle Allen wrench.

Turn the handle/knob to raise the assembly this will take the weight off the supports so you can remove them.

Top Trap Support (top) Labeler Head Support (bottom) Plastic wrapped hand wheel (right)



All top and bottom labeling heads will be supported

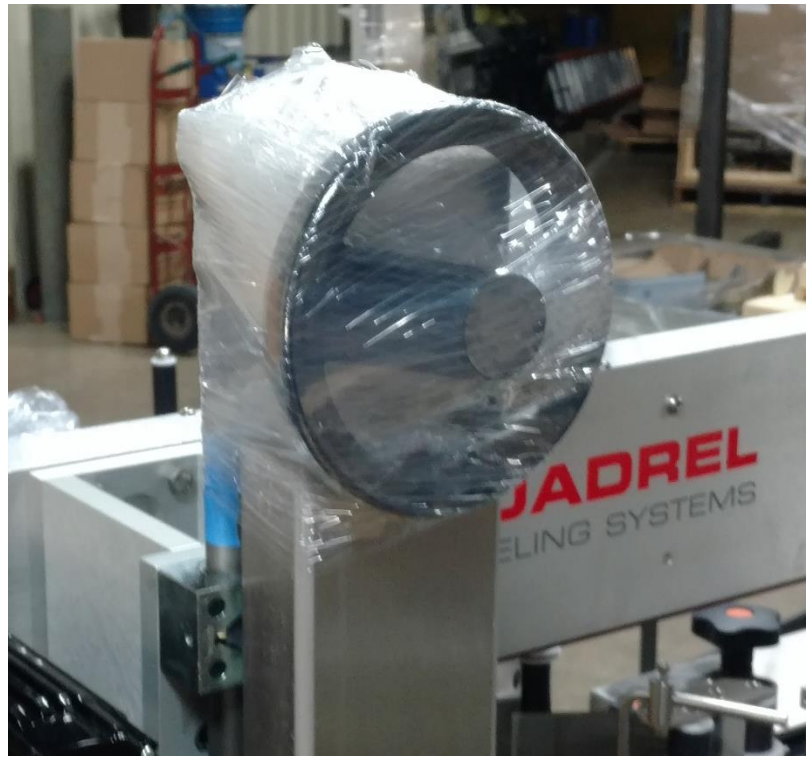

similar to the image shown on the left.

Wrap stations will have supports similar to the image to the right. These supports do not require moving the assembly.



Pacing belt assembly supports can be removed without raising the assembly.

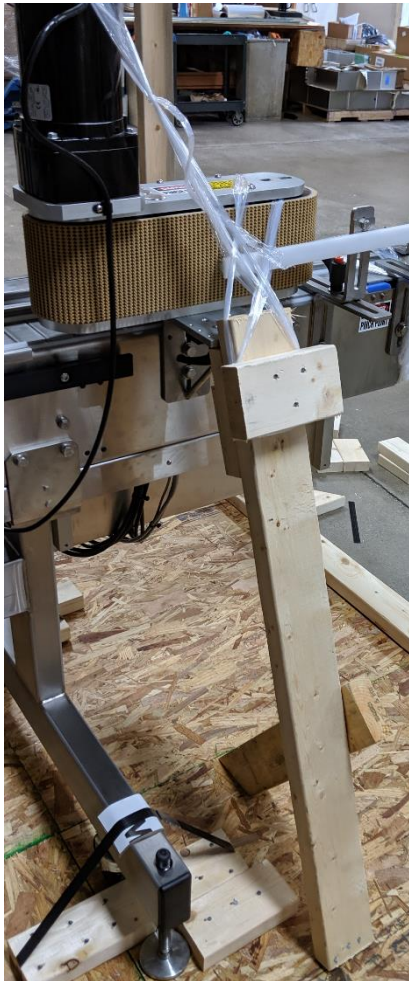

Pacing wheels supported as shown

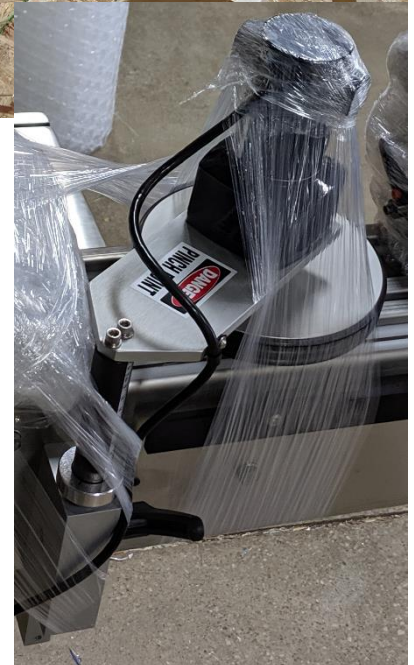



Often the head support will be moved in shipping or moved to be supported. When you are setting up your machine refer to your set up sheet in this manual. There are scales on the side of the assembly to line the carriage up to (as shown in the Image to the left and below).

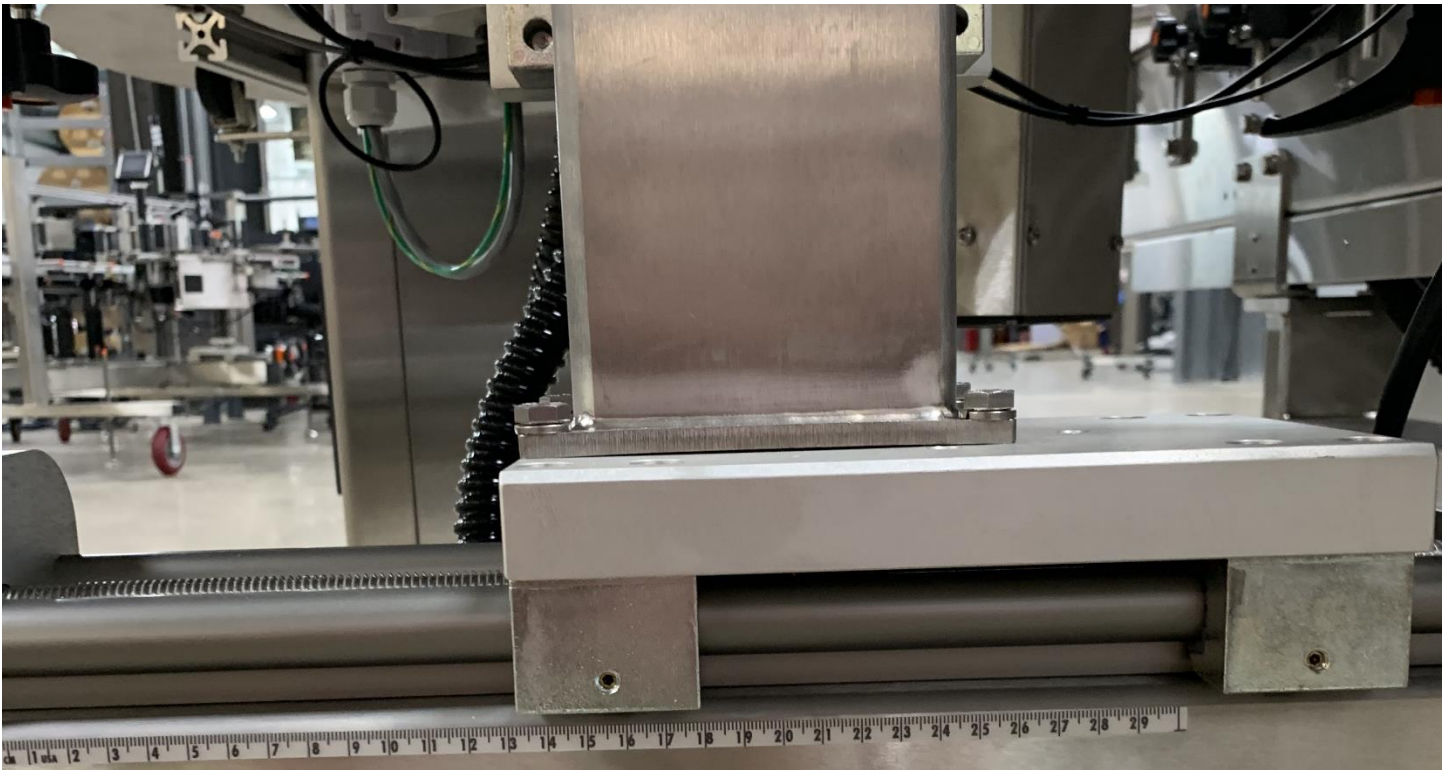

Peel plates with or without the rods may be removed from the labeling head to move the head all the way in during shipping.

All assemblies removed will be bubble wrapped then plastic wrapped to the machine (as shown in image on the right) or in box on the pallet the machine is on (as shown in image below).



Mount the peel plate assembly using a 5/16 L handle Allen wrench (as shown in image on the left). The bolts are located in the assembly. You simply put the wrench in the quick change access holes to loosen or tighten the assembly.

NOTE When you are setting up your machine make sure the peel plate assembly is perpendicular to the conveyor. When the peel plate assembly is on the rods there is a small amount of play allowing you to make small adjustments to the assembly.

If you have the peel plate rods removed with the peel plate assembly and the label detect assembly (as shown below).

All assemblies removed will be bubble wrapped then plastic wrapped to the machine or in box on the pallet the machine is on.



First back the head out all the way. Locate your peel plate assembly and slide it into the holes in the drive roll assembly (as shown on the left of the image above). Make sure you take the bolts out of the end of the rods before putting them into the drive roll assembly.



Fasten the assembly to the drive roll with the bolts supplied using a 5/16 L handle Allen wrench. Make sure you have the lock washers on the bolts.

NOTE When you are setting up your machine make sure the peel plate assembly is perpendicular to the conveyor. When the peel plate assembly is on the rods there is a small amount of play allowing you to make small adjustments to the assembly.

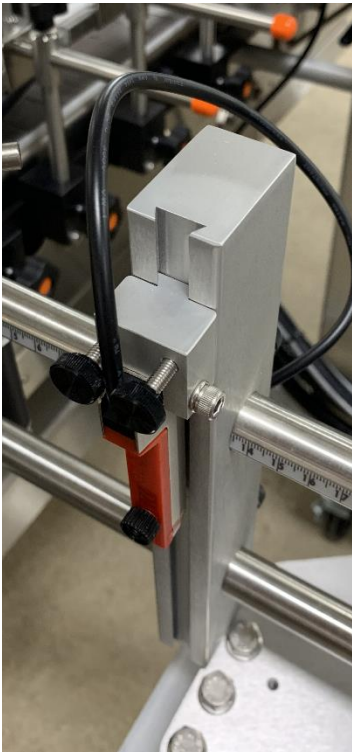

When the peel plate rods are removed the label detect sensor is removed with it (shown in image to the left). The sensor is locked into place so it won't move or need adjusted. All that will need done is simply reconnect the sensor to the zip port. To re-connect the sensor first locate the zip port (as shown in image on the right). The zip port is located under the head on the chassis or mounting plate. Take the cable coming from the sensor, route it neatly under the head, and screw it into the zip port where it says "label detect".



Some machines may have the unwind flange (shown in image to the right) removed to protect the flange during shipping do to the width of the machine.

All assemblies removed will be bubble wrapped then plastic wrapped to the machine or in box on the pallet the machine is on.

First, slide the unwind flange (with the collar facing towards you as shown in image to the right) over the unwind shaft. Make sure the top of the flange is 1 ¼ inches off the side plate.

Then, lock into place by tightening the collar with a 5/32 L handle Allen wrench.

Slide the quick lock collar over the shaft by lining the set screw up with the flat. The collar locks into place by rotating the collar 90 degrees.



Some machines may have the rewind flange (shown in image to the right) removed to protect the flange during shipping do to the width of the machine.

All assemblies removed will be bubble wrapped then plastic wrapped to the machine or in box on the pallet the machine is on.

First, slide the rewind flange (with the collar facing away from you as shown in image to the right) over the rewind hub make sure the flange just above the rubber bumper roughly 1/2 inch off the side plate.

Then, lock into place by tightening the collar with a 5/32 L handle Allen wrench.



Rails and transfers on the infeed and outfeed may be removed for shipping purposes. They will be wrapped in bubble wrap and wrapped to the machine. Carefully remove wrap and place in position as shown lock into place by tightening the knobs or ratchet handles.

NOTE Your machine may have a different rail system either adjustment is tool-less and fastened by a knob of ratchet handle.



End transfers will be wrapped in bubble wrap and plastic wrap. They will be located in a box on the pallet with your machine or wrapped to the machine itself.

Fasten the end transfer plate to the machine using a 5/32 L handle Allen wrench and the supplied 10-32 socket head screws. Ensure the transfer plate is both level with the conveyor and DOES NOT hit the conveyor chain.

Stack lamps are usually placed at the highest point of the machine and for that reason they are either removed or rotated 180 degrees. The stack lamp will wrapped in bubble wrap and wrapped to the machine.

If the stack lamp is rotated then all you need to do is remove one of the bolts, rotate the stack lamp and put the screw back in. We use various screws on stack lamps you will need one of the following tools for the job.

- 3/32 L handle Allen wrench
- 1/8 L handle Allen wrench
- 5/32 L handle Allen wrench
- 3/16 L handle Allen wrench
- 1/2 open end wrench



HMI over head touch screen displays may be laid flat across the top of the enclosure wrapped in bubble wrap and plastic wrap.

Carefully remove the plastic wrap and bubble wrap.

Rotate the HMI 90 degrees and slide into the mount on the enclosure.

Fasten the pole in place by tightening the 2 set screws on the mount with a 6MM L handle Allen wrench.



The HMI may be enclosed in a wooden support off the enclosure to hold it in place during shipping.

If HMI is located remotely off the enclosure it will still be supported during shipping.

If so, carefully remove the supports and you are done.

All printers, printer controllers and lasers are removed from the machine when shipping and placed in the manufacturer's box. The cabling will remain on the machine for ease of installation.

The printer is mounted to the printer mount with 1 ¼-20 ratchet handle. Make sure you line up the indents in the plates with the brass nut on the threaded rod. Then slide the ratchet handle through the center of all of the blocks and tighten. Plug in the cables and you are done.



Table top printers with printer tables will ship in separate boxes or pallets (as shown to the left) the printer will be disconnected and placed in the manufacturer's box. The table will either get banded to the pallet with the machine or a separate pallet tethered to the machine pallet. Printer tables may be connected to the machine via weldment or a remote from machine. If you have a weldment connected table, refer to the lay out drawing of your machine in this manual. Fasten the weldment to the frame of the conveyor using the supplied hardware and an open end wrench. If the table is remote then move into the desired position referring to your layout drawing. Remove the printer from the box set on the table and plug in the pre-wired connectors.





Print and apply printers will be removed from the labeling head as well and placed in the manufacturer's box. Your labeling head will likely ship in its own boxes with a few of the assemblies or flanges removed. Occasionally your head on a stand will ship on a framed pallet which will requires little work to get started.

The unwind flange is installed like the previous one discussed previously.

Remove the printer from the box and place it into the opening of the labeling head (as shown in image to the right). Fasten the printer to the side plate of the labeling head using the supplied (5) 10-32 socket head screws and a 5/32 L handle Allen wrench. Then, plug the printer in.

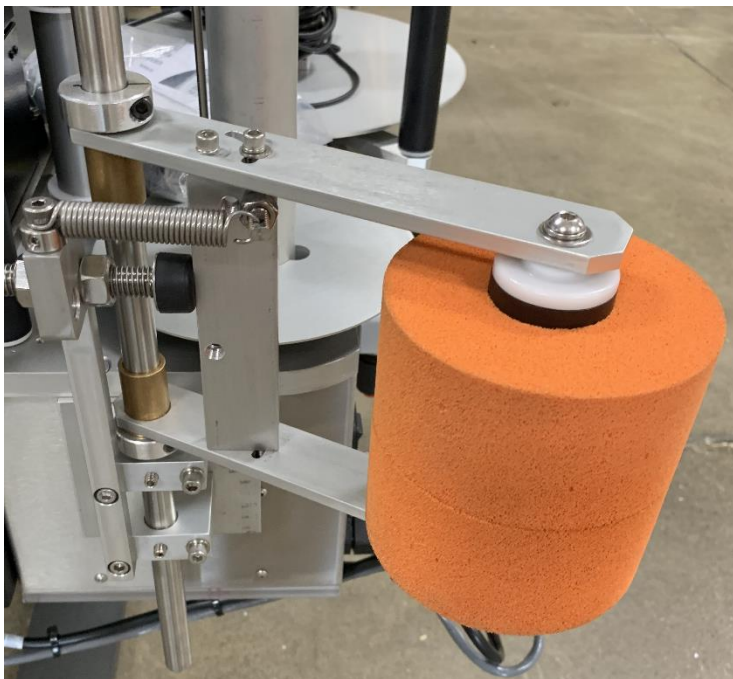

The corner wrap modules will be removed for shipping purposes. They will be wrapped in bubble wrap, plastic wrap, and placed into the box with the labeler.

Take out of the box, carefully remove the wrapping.

Then mount to the labeling head with (4) ¼-20 bolts using a 3/16 L handle Allen wrench.

To prevent kinking of the air lines during shipping on our q34 print and apply labeling heads. All lines are pulled and labeled to the corresponding color. The hoses are color coded and marked. Simply plug in hose into the matching color (as shown in image to the right).



Rotary accumulation tables are banded to a pallet and wrapped.

These tables usually operate independently to the machine.

Carefully un-band and unwrap the table.

Line it up to the transfer plate on the conveyor.

Level the table using the leveling pads.

Plus in and adjust speed through the control box.



Sleeving applicators are typically on a stand and will ship on a pallet. They will be banded have many supports and be wrapped to protect the machine during the shipping process.

Carefully remove the banding and wrapping.

Raise the head and remove the supports.

The pallet will contain boxes with. Misc assemblies and or parts (ie mandrels).



Below is an image of the mandrel. The mandrel is the most precise and important part of the sleeve system. Always handle the mandrel extremely carefully.



Your mandrel will be located on the machine pallet tethered to the machine. It will be wrapped and in a box or tube (as shown below).

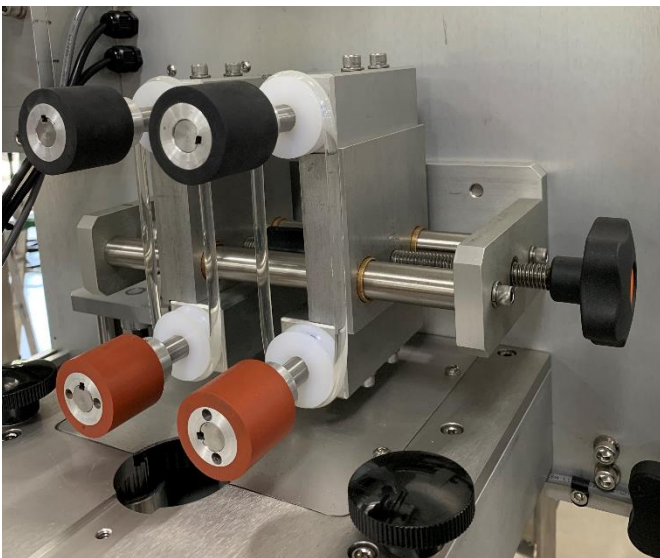

Carefully remove the mandrel from the packaging.

Rotate the black handle to move the throw down rollers apart far enough to slide the mandrel in.

Ensure each roller is between 2 bearings, the fin on the top is between the sensor, and the cutter blades are in line with the cut in the mandrel.

Rotate the black handle to move the throw down rollers closer to the mandrel pinching it in the middle. **DO NOT OVER TIGHTEN THE THROW**

DOWN ROLLERS INTO THE MANDREL. They need to be just tight enough that the bearing spins and a label feeds through.

Proline machines with guarding will either be left on the machine and have wooden supports to protect during shipping or the guards are removed and placed on a pallet.

If the guarding has supports carefully remove the supports from the guarding.

If the guarding is removed from the machine each panel will be labeled and the machine will be labeled to make it easy to figure out which door goes where.



The doors are fastened to the frame of the machine with the supplied hardware.

Line the hinges up to the holes on the frame put the bolt through.

Tighten a nut on the opposite end with the supplied flat and lock washer.





During shipment if the conveyor gets skewed you may need to re-square it. First check the conveyor with a square to verify (as shown in images below). If the conveyor needs adjusted, adjust the conveyor by slightly loosening the 4 bolts connecting the 2 sections on conveyor you would like to adjust (as shown in image to left).

Make your adjustments and check the top and side with a square. Placing a square across the top will check the squareness vertically. Placing a square along the side will check squareness horizontally.



When the conveyor is square tighten the bolts and you are all set.

When shipping a proline with an extended boom the dual swiveling elbows in the center of the boom get flipped 180 degrees to allow the machine to have enough over head clearance to ship safely (shown in image below).



Below are the instructions to flip the elbows to the correct configuration (as shown in image below)



Ensure the overhead controls are safely supported by a tow motor or at least 2 people so it does not fall when disconnecting the elbows.

Locate the 2 screws on the top and 2 screw on the bottom holding the prospective covers on.



With a t25 torx bit screw driver, loosen the 2 bolts holding the cover on the top and bottom.

With the cover off you can now access the 4 bolts holding each of the tubes in place.

Ensure the overhead enclosure is supported enough to hold for a few minutes while you loosen the bolts and flip the elbow.

Using a 6MM L handle Allen wrench loosen the 4 bolts on the top and bottom tube.



Quickly pull the tubes out and rotate the elbow as shown below.



BEFORE



AFTER

Slide the tubes in. the overhead enclosures elevation is going to change when flipping the elbows if you have it supported via tow motor you will have to raise it.

Fasten the 8 bolts with a 6MM L handle Allen wrench.

Fasten the covers to the top and bottom elbow using a T25 torx bit screw driver.



To the left shows the correct orientation of the dual elbow boom for the overhead enclosure.

If you have any questions please give our professional technicians a call.

FAMILY GUIDE



Operator Interface Guide

Econoline Labeling System with Q105/110 Labeler(s)

For SB21820-100_v001 files

Keyence N24 PLC with Delta HMI

General Overview:

The HMI communicates to a PLC and Motor Frequency Drive(s). The HMI is the master device in the system, initiating communications to all devices and passing data to each of them.

Table of Contents

Opening Splash Screen.....	3
Main Screen for Front/Back System:.....	4
Main Screen for Single Labeler system:.....	6
System Menus:.....	7
Recipe Menu:.....	9
Labeler Menu:.....	10
Labeler Service Menu:.....	12
System Speed Menu:.....	13
System Speed Calibration Menu:.....	14
Product Flow Menu:.....	15
Three Roller Indexer Menu:.....	17
Three Roller Indexer Setup Menu:.....	18
Wipe Menu:.....	20
Counters Menu:.....	21
User Menu:.....	22
Password Menu:.....	23
Fault Menu:.....	24
Fault Messages and Indicators:.....	25
Warning Messages.....	25
Fatal Messages.....	25
Fatal Messages, cont.....	26

Opening Splash Screen

Upon initial power up, the terminal will initialize and display a splash screen. The HMI will look at the PLC to determine which screen to display (Front/Back or Side/Wrap)

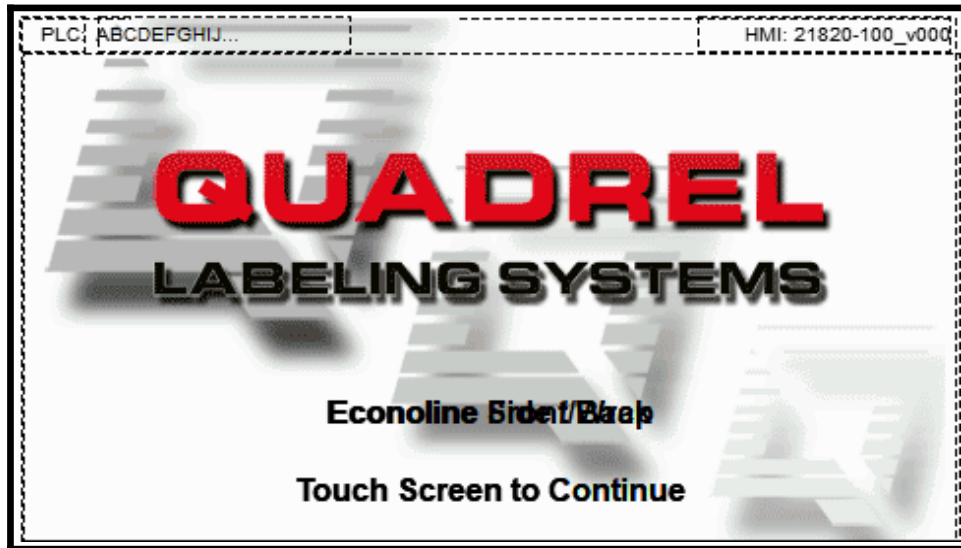

Note that the screen will be on a slight delay while the PLC and Drive boot up. During this time, the screen will display "System Starting. Please Wait"

Button / Indicator Reference:

Menu Navigation Buttons: Navigation buttons will be purple circles with white outlines and icons of the target screen. Some buttons will have text below them to identify the target screen.

Standard Buttons: Standard buttons are used to turn features on/off, reset faults, clear counters, or various other functions that require operator control. Toggle buttons will typically have icons to reflect the status of the function that is being toggled while momentary buttons like Resets are circular and do not change images/colors.

Indicators: Status Indicators will be circular and will change color based on states. Mode indicators will be oval in shape and will change colors and texts based on states.

Numeric and Text Displays: Numbers or Text displays will have a light orange background with black text, surrounded by a grey border. These are used to reflect numbers or text.

Numeric and Text Inputs: If a number can be entered, the button will have a dark green background with white text. The right side of the button will have a touch icon signify that it is an entry box.

Text Descriptions: If the description above an entry point or toggle is flashing red, it indicates the current value does not equal the saved value in the recipe. This is a reminder that the recipe must be saved in order to store the current value.



Main Screen for Front/Back System:

After touching the splash screen, the touch screen will display the Main screen. You can also get to the Main screen by pressing the Home icon (pictured left).

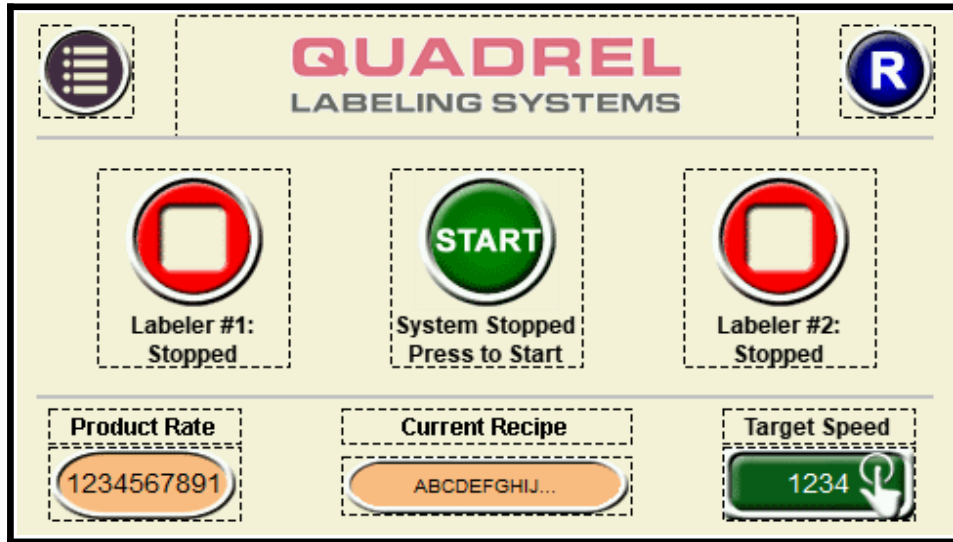

Menus Button:

Pressing this button will display all of the System Menu buttons available to the system as it is configured.

Fault/Message window:

The Red box at the top of the screen will appear if there is an active fault or message on the system. Pressing the blue Reset button to the right will clear these messages if the source of the fault has been remedied. When no faults are present, this box will disappear and a Quadrel Logo and Recipe summary will be displayed.

System Run Mode:

The conveyor and all enabled motors can be stopped and started using this button.



Green "Start" Button: Pressing this button will start the system (assuming no fatal faults are present on the system).



Red "Stop" Button: Pressing this button will stop the system.

Labeler Run/Stop:

The Labeler can be toggled between Run and Stop (pending fault conditions). The Run/Stop button will change colors and text based on the current status.



Green "Running" Button: This indicates the labeler is currently running and cannot be jogged. While running, the labeler will automatically apply labels to passing products. To **stop** the labeler, press this button.



Red "Stopped" Button: This indicates the labeler is currently stopped and may be jogged. While stopped, the labeler will ignore products passing by. To **run** the labeler, press this button.

Product Rate (Parts Per Minute):

This indicator will reflect how many parts per minute are passing by the product detect sensor. This number will start being calculated after 5 products pass and will continue to average out until no product is detected for 30 seconds.

Target Speed:

The target speed of the conveyor will be entered here as Inches per Minute.



Main Screen for Single Labeler system:

After touching the splash screen, the touch screen will display the Main screen. You can also get to the Main screen by pressing the Home icon (pictured left).

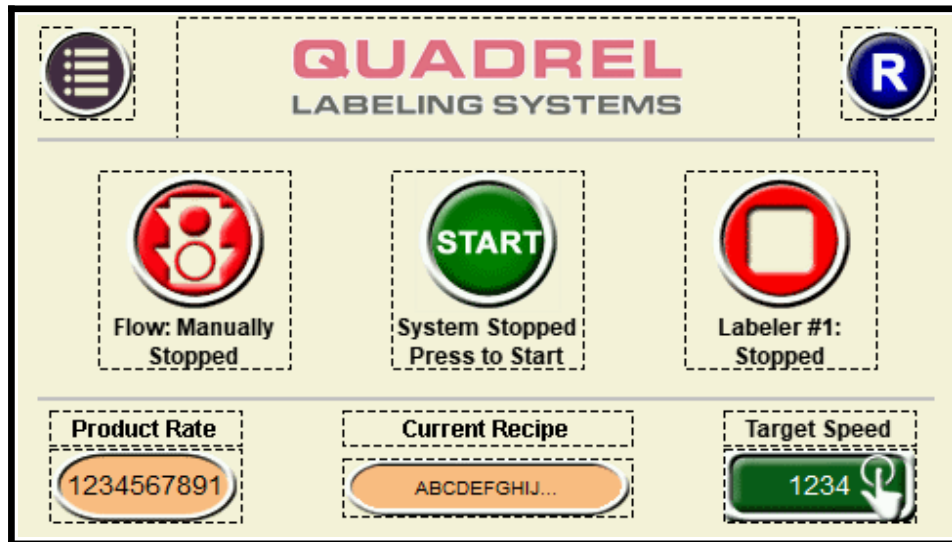

Instead of a Run/Stop toggle for Labeler #2, the main screens for Single Labeler systems will contain a Product Flow button.

Product Flow Control:

The product flow / pacing system can be stopped independently of the main system in order to prevent products from flowing into the system. This can be useful during setup or to purge the system. A pacing system can be a pacing wheel, pacing belt, or stop gate.



Green “Automatic” Button: This indicates the pacing system will stop and start the pacing system based on external conditions.

The Pacing System will stop/close when:

- The system is stopped
- The infeed sensor is not blocked by products or “starved”.
- The outfeed sensor is blocked by products or “full”.
- The Product Flow button has been toggled to “Manually Stopped”



Red “Manually Stopped” Button: This indicates the pacing system is stopped and will not allow products into the system until toggled back to Automatic.



System Menus:

After touching the button to the left from the Main screen, the actual menu will vary based on actual Machine Type. All sub menu descriptions and buttons will be listed below.

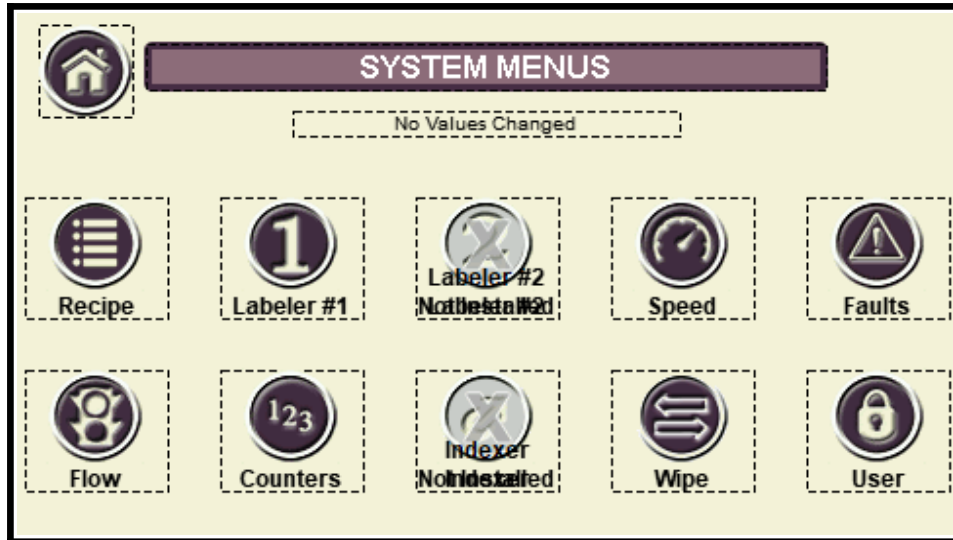

Menu buttons may be unavailable if that option is not installed or configured.



Main Menu:

Press this to return to the Main Menu.



Recipe Menu:

The system can store 9 recipes. The Recipe Menu allows saving, copying, and changing the description.



Labeler #1 Menu:

The Labeler Menu contains the parameters associated with dispensing labels onto products.



Labeler #2 Menu:

The Labeler Menu contains the parameters associated with dispensing labels onto products.



System Speed:

The System Speed menu will have all of the parameters and toggles related to the various motors on the machine.



Fault Menu:

The Fault Menu has a larger fault window to show all active fault messages on the system. Stepper Drive diagnostics can also be accessed from this menu.



Flow Menu:

The timers associated with the Product Flow / Pacing System will be in this menu.



Counters Menu:

The Product and Label Counts can be viewed and reset in the Counters Menu.



Three Roller Indexer Menu:

An optional three roller indexing module can be controlled in this menu.



Wipe Menu:

The Wipe Menu contains the toggle and parameters associated with controlling a wipe cylinder, typically used in trailing panel applications.



User Menu:

The User Menu allows an operator to log in at different levels to change protected parameters and toggles.



Recipe Menu:

The Recipe Menu allows the user to change recipes, view all recipes by descriptions, save recipes, and save recipes as new.

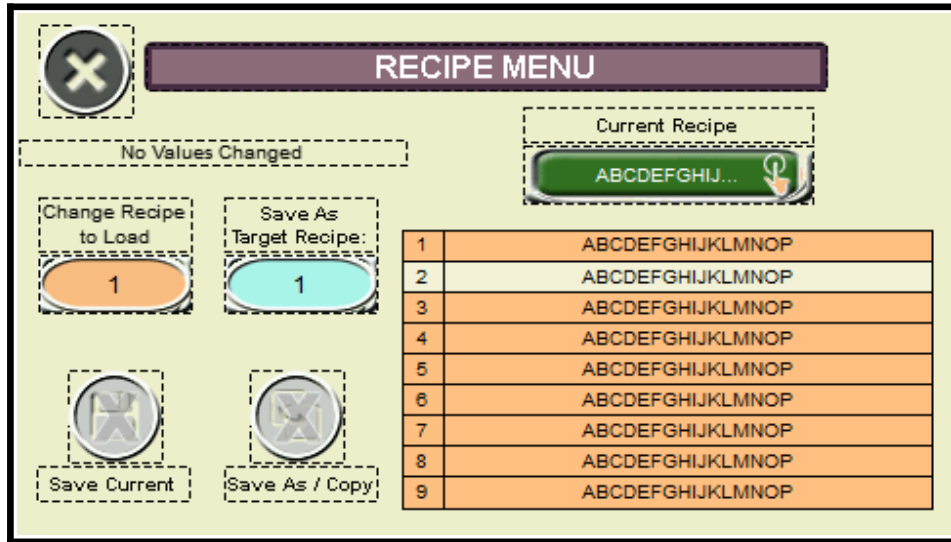

Recipe:

Recipes are presets that contain parameters unique to each product. Setting Recipes for different products expedites changeover times. A total of 9 recipes can be stored and descriptions can be changed by pressing the bottom description box when logged in at a Supervisor Level.

Recipes store the following information:

Description (displayed in the list on the center of the screen)

Speed Parameters: Target Speed, All Motor Enables, Wrap Ratio

Labeler Parameters: Product Delay, Label Stop, Max Feed, Dispense Speed / Dispense Ratio

Wipe Parameters: Wipe Enable, Wipe Delay, Wipe Duration

Roller Parameters: Escapement Delay, Escapement Duration, Capture Delay, Capture Settle Time, Registration Offset

Loading:

Recipes can be loaded by entering a new Recipe number on the left side. Once entered, all stored toggles and parameters will be loaded to the system. If a new recipe is loaded it can trigger the save button to appear in the event the system loaded default/non-zero values to various toggles and parameters.

Saving:

Pressing the purple Save button in the bottom center will save all current recipe parameters to the current Recipe number.

Save As Target Recipe (Supervisor Level):

This number can be used to create a copy of the current recipe when using the Save As button.

Save As (Supervisor Level):

Pressing the pink Save As button in the bottom left will save all current recipe parameters to the Save As Recipe number. Note that this button does not save the current values to the current recipe.

Change Description (Supervisor Level):

Pressing the Recipe Description at the top will bring up a keyboard that allows the user to enter a new description for the current recipe.

1 Labeler Menu:

After touching the button to the left from the Menus screen, the following screen appears. Note that the fault display will still appear over the title bar if the system has an active fault.

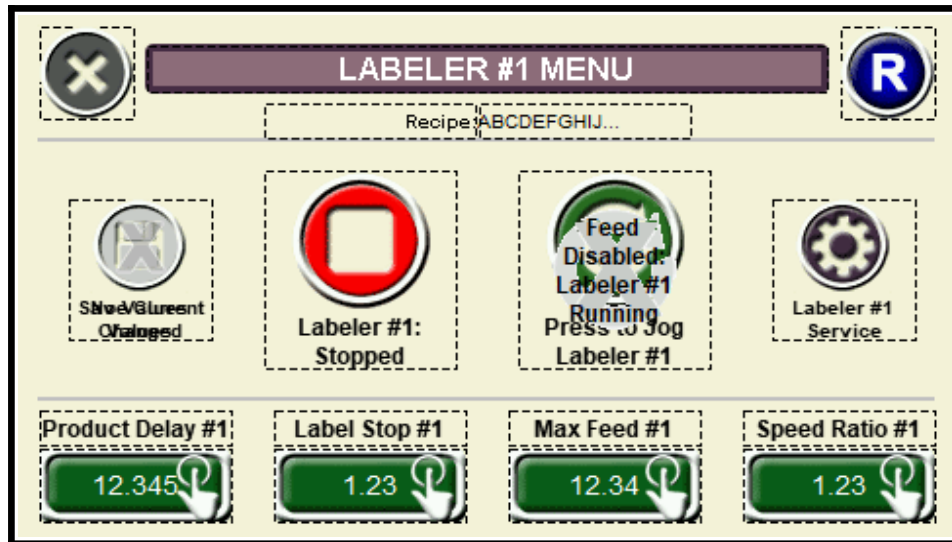

Close / Back:

Press this to return to the previous screen.



Labeler Service Menu:

The Labeler Setup Menu contains core values related to the dispensing speed of the labeler. These are typically set up at the factory and don't need further adjustment.

Labeler Run/Stop:

The Labeler can be toggled between Run and Stop (pending fault conditions). The Run/Stop button will change colors and text based on the current status.



Green "Running" Button: This indicates the labeler is currently running and cannot be jogged. While running, the labeler will automatically apply labels to passing products. To **stop** the labeler, press this button.



Red "Stopped" Button: This indicates the labeler is currently stopped and may be jogged. While stopped, the labeler will ignore products passing by. To **run** the labeler, press this button.

Labeler Jog:

When the Labeler is stopped, the Jog button becomes available. Pressing the Jog button will cause the labeler to dispense one label (pending proper threading and label gap detection). It is important to jog labels upon threading or changing over to verify the labeler is threaded and functioning properly.



Green "Jog" Button: This indicates the labeler can be jogged. Press this button to start a jog process. This button will be grey while the labeler is jogging.



Greyed out "Jog" Button: This indicates the labeler is currently running, and may not be manually jogged.

Product Delay:

The Product Delay is used to center the label on the product in the left/right direction. A higher value in the Product Delay parameter will move the label towards the infeed side of the conveyor.

The Product Delay value is entered as inches.

Label Stop:

The Label Stop controls the label's stop position. Typically the label should stop with 1/8" to 1/4" sticking off of the peel plate. A higher Label Stop will result in more label off of the peel plate. The Label Stop value is entered as inches.

Max Feed Length:

The Max Feed controls how much liner (in inches) will be dispensed in the event no label gap is found. This is to prevent label runaway conditions and can be used to determine if labels are missing on the liner.

After a label is set up properly, this value can be set to the label length + .25.

When setting up a new label, it may be necessary to set this value to 2x the actual label length. This will allow the labeler to dispense more label to find and process the label stop value.

Speed Ratio:

This is a speed ratio based on the target speed of the conveyor that determines the dispensing speed of the labeler. A value of 1.00 means the labeler will dispense at the target conveyor speed.

**Saving:**

When any of the stored recipe values are changed, the Save button will appear. The Save button must be pressed to save settings to the current recipe.

The text above any parameter will flash if it has been changed.



Labeler Service Menu:

After touching the button to the left from the Labeler Menu, the following screen appears.

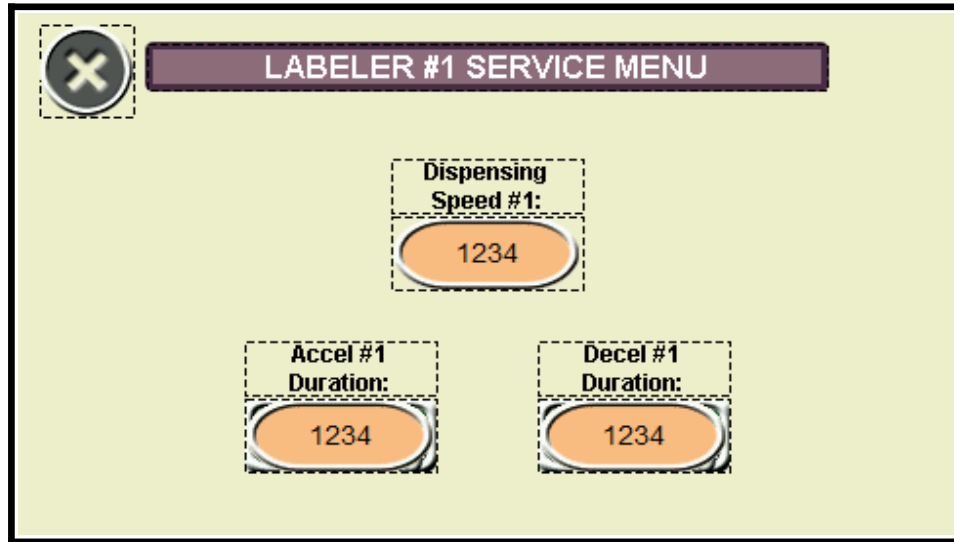

Close / Back:

Press this to return to the previous screen.

Dispensing Speed:

This indicator reflects the current dispensing speed of the labeling head in inches per minute. It is calculated by Target Speed x Speed Ratio.

Accel (Supervisor Level):

The Accel Duration (entered in milliseconds x 10) is the rate at which the label will reach the target dispensing speed. Too low of a value may result in motor stalling or liner tears. Too high of a value may result in the label not being dispensed in time to reach production rates.

Decel (Supervisor Level):

The Decel Duration (entered in milliseconds x 10) is the rate at which the label will come to a stop. Too low of a value may result in problems attempting to label the next product. Too high of a value may result in erratic label stop.



System Speed Menu:

After touching the button to the left from the System Menu screen, the following screen appears.

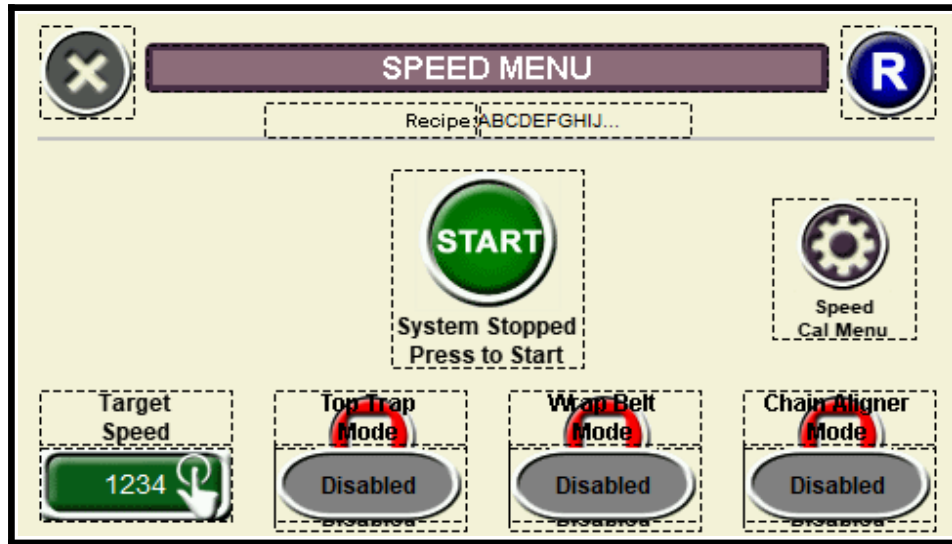

Close / Back:

Press this to return to the previous screen.

Target Speed:

The Target Speed entry box changes the speed of the system. It will be entered as inches per minute (200-1600).

Top Trap (Supervisor Level):

The Top Trap is a belt that touches the top of the product and keeps it contained throughout the labeling process.

Wrap Belt (Supervisor Level):

The Wrap Belt is mounted to the conveyor and is used to wipe down the label on round products. The Wrap Belt can be mounted directly at the labeling head (called a Direct Wrap application) or past the Top Trap (called a Flag and Wrap application).

Chain Aligners (Supervisor Level):

Chain Aligners are spring loaded belts that are used for centering non-squared (typically oval shaped) containers before they enter the top trap.



System Speed Calibration Menu:

After touching the button to the left from the System Menu screen, the following screen appears.

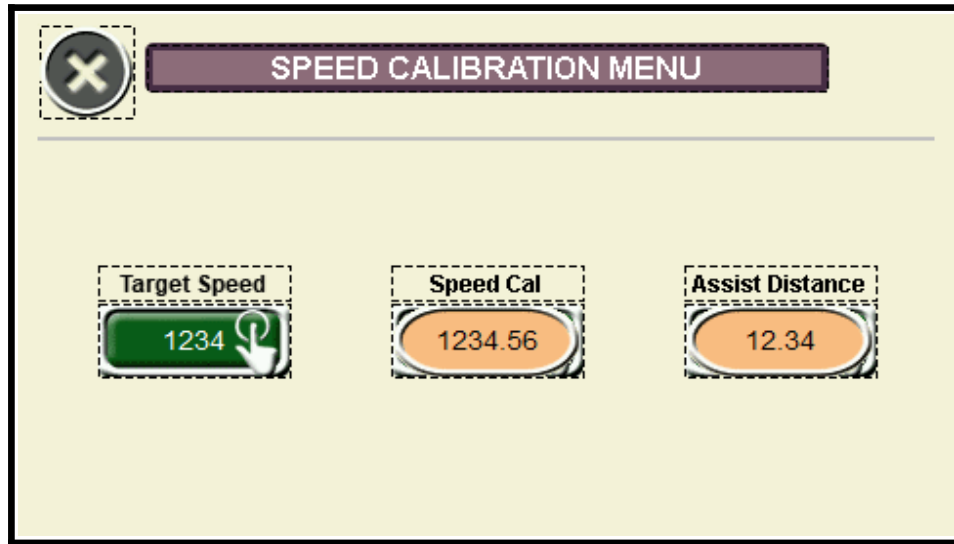

Close / Back:

Press this to return to the previous screen.

Target Speed:

The Target Speed entry box changes the speed of the system. It will be entered as inches per minute (200-1600).

Speed Calibration (Supervisor Level):

This value allows the conveyor to run at the target speed. This value is calculated at the factory using a tachometer and should not need adjustment unless drive parameters are changed.

Air Assist Distance (Maintenance Level):

If the Top Trap and Wrap are both enabled, it's assumed the system is in a flag & wrap setup. When Labeler #1 dispenses a label in a flag & wrap setup, the air assist tube will turn on for a distance in inches equal to the Air Assist Distance.



Product Flow Menu:

After touching the button to the left from the System Menu screen, the following screen appears. Note that the fault display will still appear over the title bar if the system has an active fault.

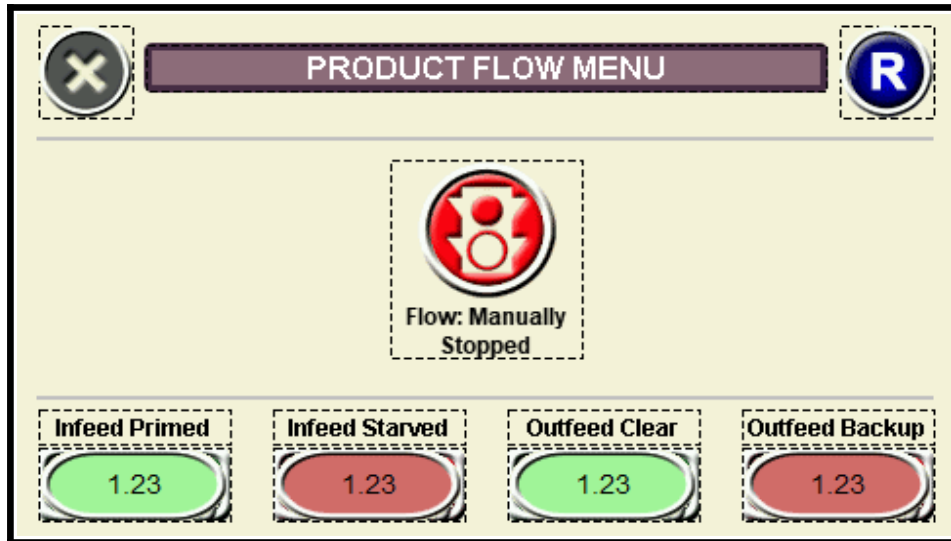

Close / Back:

Press this to return to the previous screen.

Product Flow Mode:

The Pacing motor or Stop Gate (optional), and bank sensors (optional) will function together to allow smooth product flow into the system. They are also used to prevent products from entering the system when certain conditions are not met.



Green "Automatic" Button: This indicates the installed devices will start/stop or open/close when certain conditions are met. Conditions that stop the product flow are displayed in the fault menu.



Red "Manually Stopped" Button: This indicates the product flow system is stopped and will now allow products to enter until toggled to "Automatic".

The Product Flow stop/close when:

- The system is stopped
- The infeed sensor is not blocked by products: empty/starved.
- The outfeed sensor is blocked by products: full/backed up.
- The Product Flow button has been toggled to "Manually Stopped"

Status Indicator:

The indicator below the Flow Mode button reflects the status of the flow system.

Red: Manually Stopped. The Flow Mode is in the manually stopped state and will not allow products to enter.

Yellow: Waiting. The flow system is not allowing products to enter the system due to a condition mentioned above not being met.

Green: Running/Open. Products are currently entering the system.

Infeed Starved Delay (Maintenance Level):

This timer will start when the Infeed sensor does NOT see products, which results in an Empty/Starved condition. After this timer expires, the product flow will stop.

Infeed Primed Delay (Maintenance Level):

This timer will start when the Infeed sensor sees products, which results in a Primed/Full condition. After this timer expires, the product flow will start.

Outfeed Clear Delay (Maintenance Level):

This timer will start when the Outfeed sensor does NOT see products, which results in a Clear/Empty condition. After this timer expires, the product flow will start.

Outfeed Full Delay (Maintenance Level):

This timer will start when the Outfeed sensor sees products, which results in a Backed Up/Full condition. After this timer expires, the product flow will stop.



Three Roller Indexer Menu:

After touching the button to the left from the System Menu screen, the following screen appears.

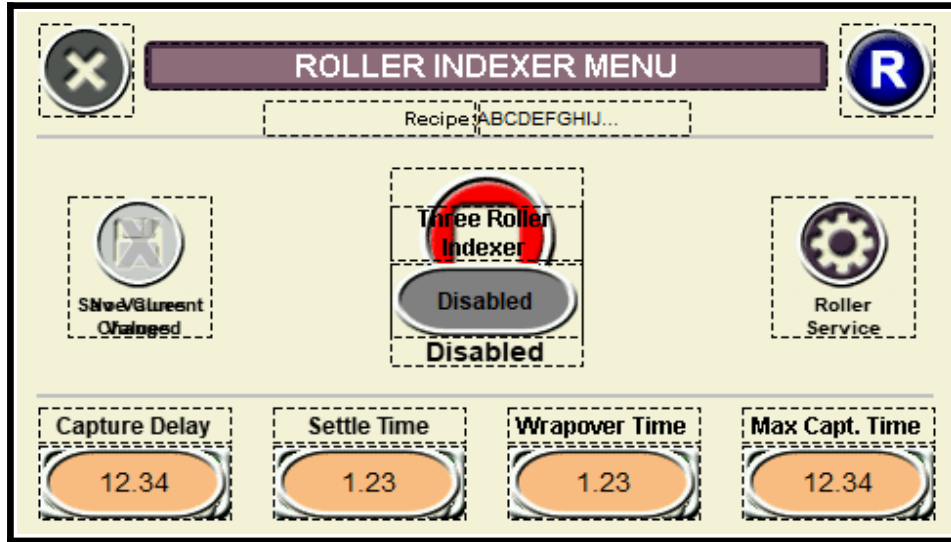

Close / Back:

Press this to return to the previous screen.

Three Roller Mode (Supervisor Level):

The system can utilize a roller indexing station to trap products and dispense labels based on an optional registration mark.



Enabled: The system will use an escapement to allow products through the system. After exiting the escapement, the roller will extend and capture the product against the wrap belt. While captured, a registration sensor may be monitored to determine when the label is dispensed.



Disabled: The Roller and Escapement will not function.

Capture Delay (Maintenance Level):

After a product passes the product detect sensor, this is the distance (in inches) until the roller extends to capture a product.

Settle Delay (Maintenance Level):

When the Roller extends, this timer will start (entered in seconds). After this timer expires, the registration sensor will be monitored or label will be dispensed. This timer is used to make sure the product is properly captured before monitoring the registration sensor. Note that the settle timer starts once the roller solenoid is energized.

Wrapover Time (Maintenance Level):

After the label is dispensed, the Wrapover timer (entered in seconds) begins. After this timer expires, the Roller station will retract and release the product.

Maximum Capture Tim (Maintenance Level):

This timer is used to monitor the overall process. If this timer (in seconds) expires prior to a product being released, a fault will occur.



Three Roller Indexer Setup Menu:

After touching the button to the left from the Roller Indexer Menu screen, the following screen appears.

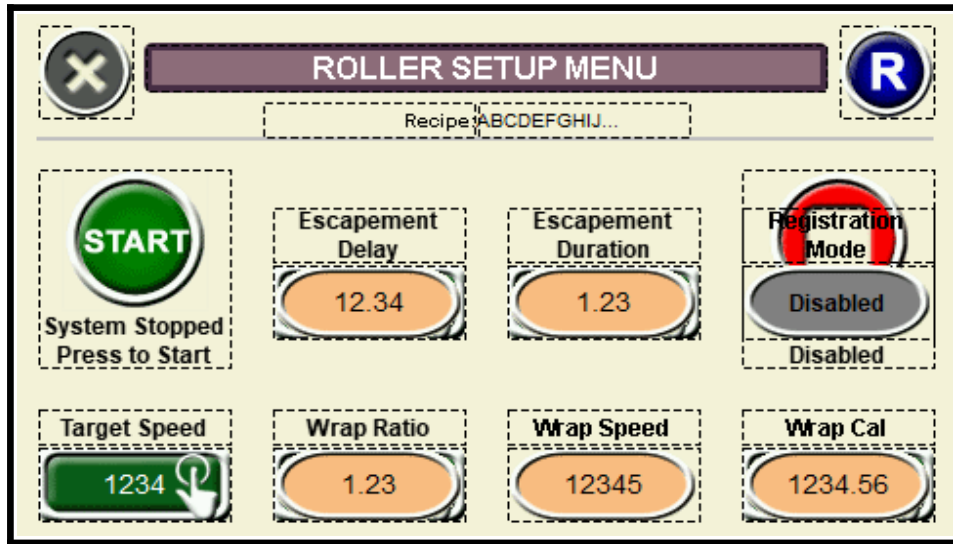

Close / Back:

Press this to return to the previous screen.

Escapement Delay (Maintenance Level):

When the Escapement Sensor is blocked and system is running, this timer (in seconds) will start. Once the timer expires, the escapement will activate to release a product.

Escapement Duration (Maintenance Level):

When the Escapement becomes active to release a product, this timer (in seconds) will start. Once the timer expires, the escapement will deactivate. This timer should be set so the escapement properly releases a product.

Registration Mode (Supervisor Level):

This determines if the Registration sensor will be used when products are captured in the roller system.



Enabled: The system will use a registration sensor to determine when a label is dispensed on a product that is captured in the roller.



Disabled: The system will dispense a label based on the Product Delay parameter only after a product is captured.

Target Speed:

The Target Speed entry box changes the speed of the system. It will be entered as inches per minute (200-1600).

Wrap Speed Ratio (Maintenance Level):

This entry box determines the speed of the Wrap Belt. It is a speed ratio compared to the Target Conveyor Speed.

Target Wrap Speed:

This display will show the target wrap speed in Inches per minute. It is calculated by Target Conveyor Speed x Wrap Ratio.

Wrap Calibration (Supervisor Level):

This value allows the wrap to run at the target speed. This value is calculated at the factory using a tachometer and should not need adjustment unless drive parameters are changed.



Wipe Menu:

After touching the button to the left from the System Menu screen, the following screen appears. Note that the fault display will still appear over the title bar if the system has an active fault.

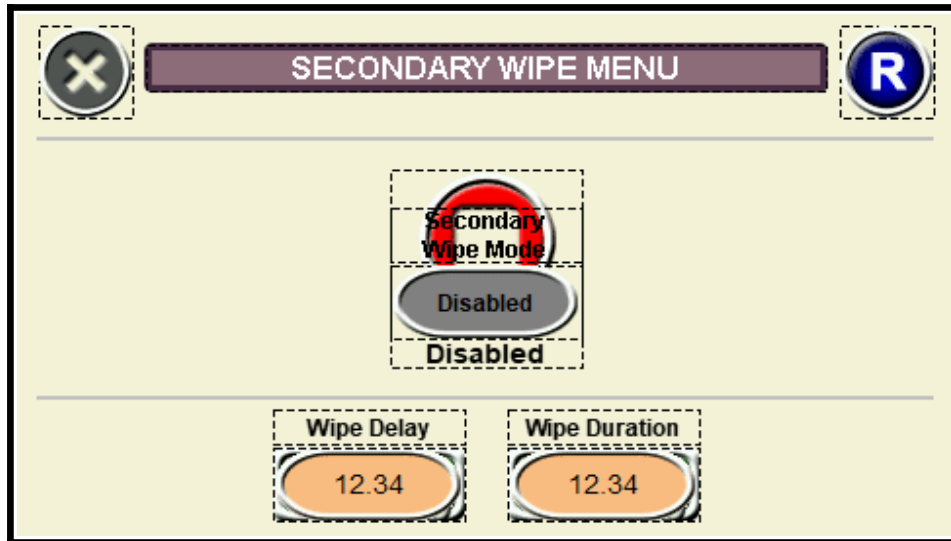

Close / Back:

Press this to return to the previous screen.

Secondary Wipe (Supervisor Level):

The system can control a secondary wipe cylinder that uses its own trigger sensor and delay settings. This is common in Trailing Panel applications, but could be used for other applications if needed.

The secondary wipe function is a single action event in one signal = one wipe. If the trigger is activated again prior to the wipe extending & retracting that signal is ignored.



Enabled: This indicates the wipe function is enabled. After the trigger sensor is activated, the system will wait for a specified amount of time (Wipe Delay) before energizing the output for the wipe cylinder or device. Note that the output will not energize if the Labeler is stopped.



Disabled: The output for the cylinder or device will not turn on.

Wipe Delay (Maintenance Level):

The Wipe Delay (entered in Seconds) is how long the system waits from the trigger sensor being activated until the output for the cylinder or device is turned on.

Wipe Duration (Maintenance Level):

The Wipe Duration (entered in Seconds) is how long the output remains on once it is activated.



Counters Menu:

Product and Label Counters can be viewed and reset here.

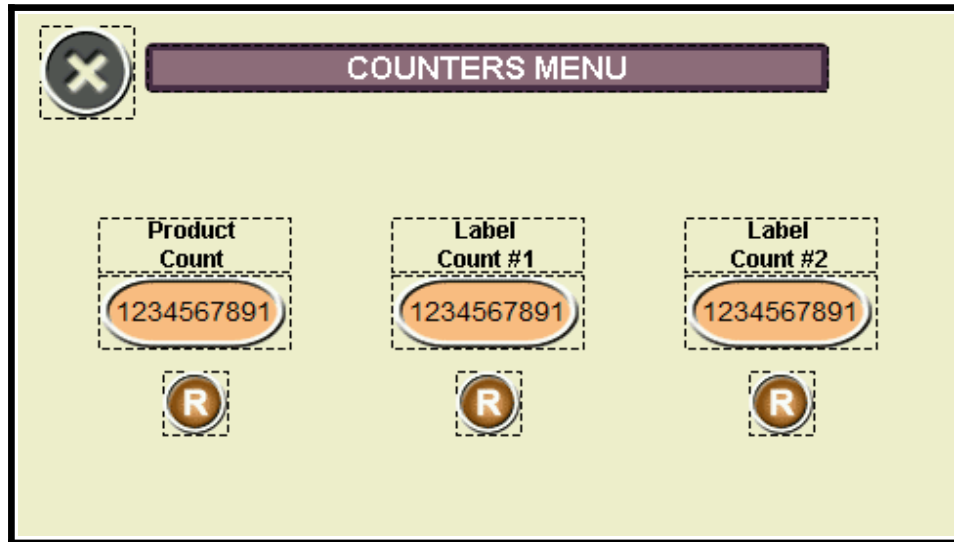

Close / Back:

Press this to return to the previous screen.

Product Count and Reset:

This counter reflects how many Products have passed the product detect sensor while any labeler is Running. The reset button below the counter will set this value to 0.

Label Count and Reset:

This counter reflects how many Labels have been dispensed when Jogging and Running. The reset button below the counter will set this value to 0.



User Menu:

Log in, Log Out, and Set Custom Passwords

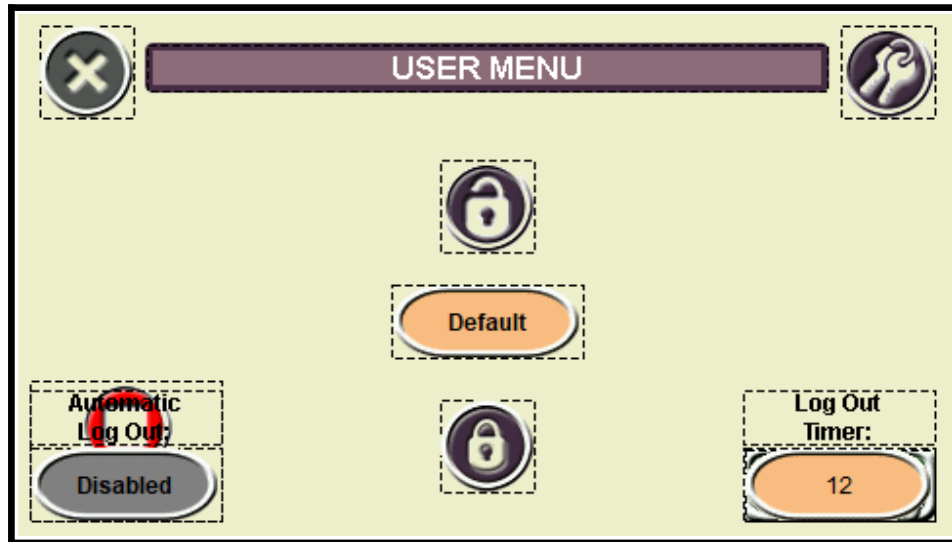

Close / Back:

Press this to return to the previous screen.



Password Input: Press this button to enter a user password.



Log Out: Press this button to enter to log the current user out.



Password Menu: This will open up a security prompt before opening the password menu, where the passwords for the Maintenance and Supervisor levels are set.

Auto Log Out (Supervisor Level):

When Enabled (button will be Green), the logged in user will automatically be logged off at a set amount of time. Note that the system automatically enables the Auto Log Out feature upon startup.

Log Out Timer (Supervisor Level):

This timer (in minutes) determines the time it takes to log off a user if Auto Log Out is enabled.



Password Menu:

The Password Menu allows the creation and editing of the passwords for different security levels.

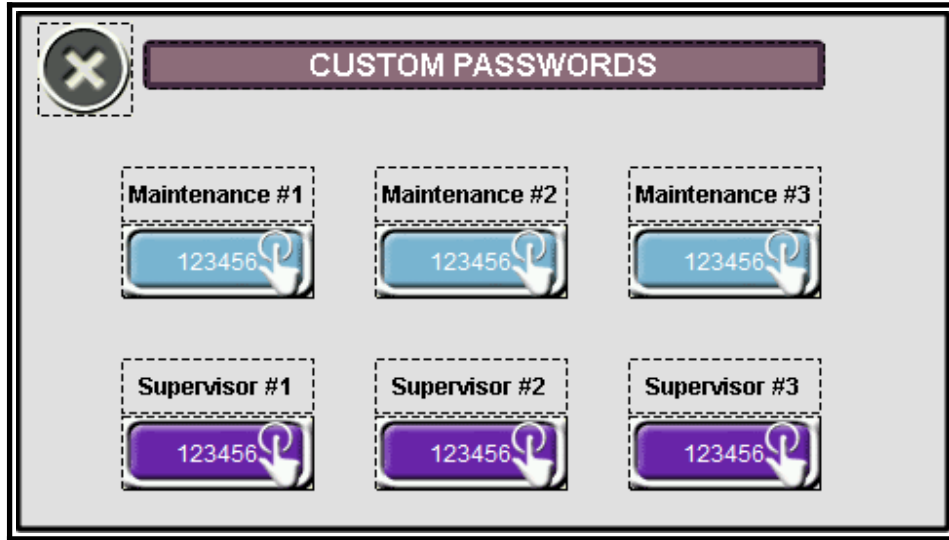

Maintenance:

There can be 3 user defined passwords for the Maintenance level. Note that there is one hard coded Maintenance Level password that cannot be viewed or changed.

Supervisor:

There can be 3 user defined passwords for the Supervisor level. Note that there is one hard coded Supervisor Level password that cannot be viewed or changed.

If a Maintenance and Supervisor password are the same, the system will log that user in at the Maintenance level.

The password(s) to open the Password Menu are stored in the HMI and cannot be modified. This will prevent any password loss in the event the PLC logic is altered.



Fault Menu:

The Fault Menu displays all fault messages, shows system level counters, and gives access to a Fault History. You can access this Menu by pressing the Alert icon (pictured left).

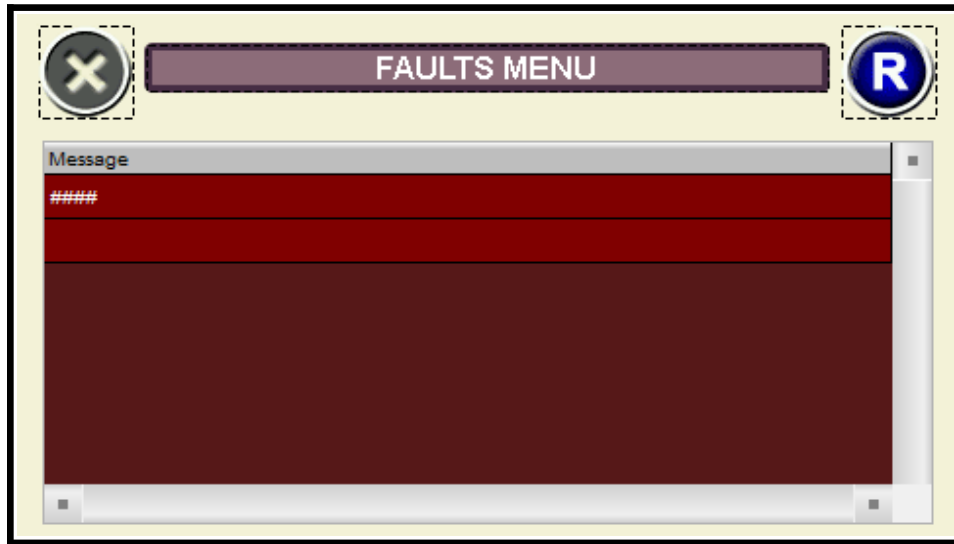

Fault/Message window:

The Red box in the middle of the screen will display any active fault or message on the system. Pressing the blue Reset button will clear these messages if the source of the fault has been remedied. If multiple faults exist, it is necessary to scroll down to view them.

Fault Messages and Indicators:

Green Lamp (option): A Green lamp will be steady to signal the labeler is free of all faults.

Amber Lamp (option): An Amber lamp will signal that there is a warning condition present on the system. Warning conditions typically allow the system to function normally, but action will be needed soon to replace labels, ribbon, etc. Some warning messages will turn into fatal faults if they are not addressed before taking additional actions.

Red Lamp / Buzzer (option): A Red lamp indicates that a fatal fault occurred and the system is unable to run properly.

Messages	Cause/Solution
Warning Messages	
Screen Boot Sequence Warning	The PLC will not execute it's internal program until the screen starts up. If the PLC powered was cycled but screen was not, this message will appear. Cycle power to the entire labeling head.
Low Label Supply #X	The label supply on the listed labeler has been determined low by the sensor fiber under the flange. Note that this message will not appear until the labeler is placed in run or is currently running.
End of Web Warning #X	The End Of Web sensor (between the drive system and unwind) on the listed Labeler is active and the Labeler is Stopped. Placing the Labeler into Run will generate a Fatal Fault.
Broken Web Warning #X	The Broken Web sensor (between the drive system and rewind) on the listed Labeler is active and the Labeler is Stopped. Placing the Labeler into Run will generate a Fatal Fault.
Missing Label / Max Feed #X	This message will appear if the drive determined there was no label gap detected when dispensing. Check the Max Feed distance, label sensor, and labels if this frequently occurs.
Infeed Starved / Outfeed Full. Product Flow Stopped	The Product Flow device is currently stopped because the Infeed area is starved of products and/or the outfeed area is full of products.
Labeler #X Drive Faulted Warning	The driver that controls the stepping motor on the labeler has been turned off or has become faulted. The warning indicated the labeler is Stopped. Placing the Labeler into Run will generate a Fatal Fault.
Product Delay Warning	The system attempted to apply a label to a product but was already in a dispensing process. Verify the products are properly spaced and/or increase the Product Delay parameter.

Fatal Messages	
Safety Fault. Check E-Stops	An emergency stop is pressed in. When released, the safety circuit will restart, but the fault message must be manually cleared from the HMI.
Labeler #x Drive Faulted / Turned Off	The driver that controls the stepping motor on the labeler has been turned off or has become faulted. Refer to the stepper drive manual to read fault codes on the drive itself. This fault will become active if the labeler is Running or placed into Run.
Labeler #x Broken Web Fault	The Broken Web sensor (between the drive system and rewind) on the Labeler is active and the Labeler was Running or placed into Run.
Labeler #x End of Web Fault	The End Of Web sensor (between the drive system and unwind) on the Labeler is active and the Labeler was Running or placed into Run.

Fatal Messages, cont.

Missing Label / Max Feed #X	This message will appear if the drive determined there was no label gap detected when dispensing. Check the Max Feed distance, label sensor, and labels if this frequently occurs.
DRx Faulted	The listed drive did not send data back to the PLC that it is running when the system was started. Check that the drive is powered up, has no faults, and communication cabling is correct.
Movement Error, Press Reset	The system attempted to dispense a label but could not due to an invalid parameter. Verify that a max feed and dispense speed is set.
Roller Timeout Fault	The Roller Indexer process timed out. This can be from a Max Capture Time value being set too low, product not being captured properly, or registration feature not detected.
Roller Not Home Fault	The Roller Indexer was requested to capture a product, but the home sensor on the cylinder was not active. This can be from products being too close, loss of air pressure, faulty home sensor, or cylinder pinching an object like a cable or hose.

To set user passwords during initial setup navigate to the passwords screen, then Log in using password "7670" Once logged in users can set passwords per HMI Guide.

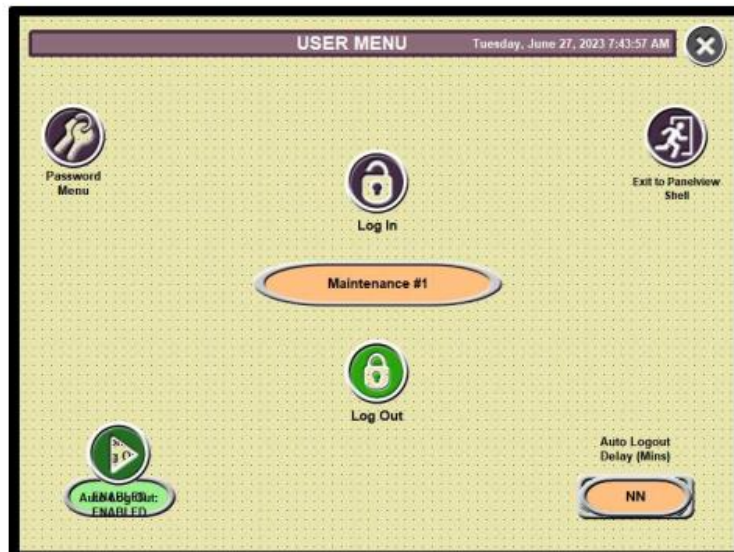
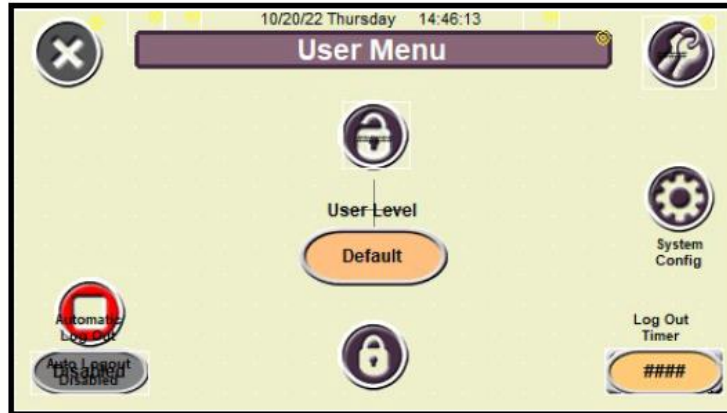

USER MENU 

Sunday mm/dd/yy HH:MM:SS

 Passwords



Current User:
Default



 Log Out
Disabled

Log Out
Timer:
12:34 

Setup sheets

QUADREL

LABELING SYSTEMS

Serial Number: 84271

Label Size: 5 x 7 Product 1 Gallon Grey

Recipe # 1

Labeler Menu

	LABELER 1	LABELER 2
Product Delay	8.10	8.20
Label Stop	3.90	4.00
Max Feed	6.00	6.00
Speed Ratio	.97	.97

Labeler Setup Menu

	LABELER 1	LABELER 2
Accel	2500	2500
Decel	2500	2500

Speed Menu

Target Speed	1000	
Top Trap	Enable <input checked="" type="checkbox"/>	Disable <input type="checkbox"/>
Wrap Belt	Enable <input type="checkbox"/>	Disable <input checked="" type="checkbox"/>
Chain Aligner	Enable <input checked="" type="checkbox"/>	Disable <input type="checkbox"/>

Speed Calibration Menu

Target Speed	1000
Speed Cal	12
Assist Distance	xxxx

Product Flow Menu

Infeed Primed Delay	xxxx
Infeed Starved Delay	xxxx
Outfeed Clear Delay	xxxx
Outfeed Full Delay	xxxx

QUADREL

LABELING SYSTEMS

Secondary Wipe Menu

Wipe	Enable <input type="checkbox"/>	Disable <input checked="" type="checkbox"/>
Wipe Delay		xxxx
Wipe Duration		xxxx

Mechanical Settings

	Labeler 1	Labeler 2
Labeler Up/Down	1865	2138
Labeler In/Out	376	99069
Top Trap Up/Down	98079	
Pace Speed Dial	40	

QUADREL

LABELING SYSTEMS

Serial Number: 84271

Label Size: 5 x 7 Product 1.25 Gallon Grey

Recipe # 2

Labeler Menu

	LABELER 1	LABELER 2
Product Delay	7.9	7.9
Label Stop	3.90	4.00
Max Feed	6.00	6.00
Speed Ratio	.97	.97

Labeler Setup Menu

	LABELER 1	LABELER 2
Accel	2500	2500
Decel	2500	2500

Speed Menu

Target Speed	1000	
Top Trap	Enable <input checked="" type="checkbox"/>	Disable <input type="checkbox"/>
Wrap Belt	Enable <input type="checkbox"/>	Disable <input checked="" type="checkbox"/>
Chain Aligner	Enable <input checked="" type="checkbox"/>	Disable <input type="checkbox"/>

Speed Calibration Menu

Target Speed	1000
Speed Cal	12
Assist Distance	xxxx

Product Flow Menu

Infeed Primed Delay	xxxx
Infeed Starved Delay	xxxx
Outfeed Clear Delay	xxxx
Outfeed Full Delay	xxxx

QUADREL

LABELING SYSTEMS

Secondary Wipe Menu

Wipe	Enable <input type="checkbox"/>	Disable <input checked="" type="checkbox"/>
Wipe Delay		xxxx
Wipe Duration		xxxx

Mechanical Settings

	Labeler 1	Labeler 2
Labeler Up/Down	803	1051
Labeler In/Out	376	99069
Top Trap Up/Down	96997	
Pace Speed Dial	40	

QUADREL

LABELING SYSTEMS

Serial Number: 84271

Label Size: 6 x 6.25 Product 1 Gallon Black

Recipe # 3

Labeler Menu

	LABELER 1	LABELER 2
Product Delay	8.2	8.2
Label Stop	2.90	3.0
Max Feed	7.00	7.00
Speed Ratio	.97	.97

Labeler Setup Menu

	LABELER 1	LABELER 2
Accel	2500	2500
Decel	2500	2500

Speed Menu

Target Speed	1000	
Top Trap	Enable <input checked="" type="checkbox"/>	Disable <input type="checkbox"/>
Wrap Belt	Enable <input type="checkbox"/>	Disable <input checked="" type="checkbox"/>
Chain Aligner	Enable <input checked="" type="checkbox"/>	Disable <input type="checkbox"/>

Speed Calibration Menu

Target Speed	1000
Speed Cal	12
Assist Distance	xxxx

Product Flow Menu

Infeed Primed Delay	xxxx
Infeed Starved Delay	xxxx
Outfeed Clear Delay	xxxx
Outfeed Full Delay	xxxx

QUADREL

LABELING SYSTEMS

Secondary Wipe Menu

Wipe	Enable <input type="checkbox"/>	Disable <input checked="" type="checkbox"/>
Wipe Delay		xxxx
Wipe Duration		xxxx

Mechanical Settings

	Labeler 1	Labeler 2
Labeler Up/Down	1567	1823
Labeler In/Out	584	98848
Top Trap Up/Down	97782	
Pace Speed Dial	50	

Fuji Frenic Mini v.011

For use with Econolines with Keyence Nano PLC & Delta HMI

Job: 84271-100 Drive: 1 Motor: Conveyor

SETUP AND ADJUSTMENTS: (Reference Fuji drive manual for detailed information)

Set Primary Parameters:

Parameter	Fuji Default	Quadrel Default Value	Quadrel Final Value	Description
F01	4	0 (Keypad)	1 ✓	Freq. Command
F02	2	1 (Terminals)	1 ✓	Operation
F03*	60.0	60.0	90	Max Frequency
F07	6.0	3.0	3.0	Accel Time
F08	6.0	3.0	3.0	Decel Time
F15	70	70	90	Frequency Limit
F42	0	2	2 ✓	Control Mode
H30**	0	1	1 ✓	Comm Function
E27	99	0	0 ✓	Relay Function
P99	0	1 (HP)	1 ✓	Motor Type
P02	Varies	See Motor Nameplate	.38	Rated Capacity (HP)
Y01***	1	1	1 (Conveyor Only) ✓	Drive Address
Y10	1	2	2 ✓	Protocol

*: If F03 needs to be greater than 70.0 (F15 Default), F15 must be changed first.

**: 1 for Conveyor or Three Roller Wrap. 0 for all others.

***: 1 for Conveyor, 2 for Three Roller Wrap

P02 Reference for frequently used motors:

3/8 HP: 0.38, 1/6 HP: 0.17

Initialize Parameters

- Navigate to Parameter H03
- Use the STOP and UP Arrow to change H03 to "2". Press the Func/Data button.
- "Save" will flash on the display. H03 will revert back to "0" once the parameters are automatically set.

Set the Motor Current based on the Motor Nameplate value. Entered as Amps.

Parameter	Fuji Default	Motor Nameplate	Quadrel Final value
P03	Varies	1.9	1.9

P03 Reference for frequently used motors:

3/8 HP: 1.9, 1/6 HP: 0.73

S03 Jumper Setting:

Default is in the OFF position.

Standard Systems: Set DR1 Conveyor to ON position. Other drives set to default/OFF.

Three Roller Systems: Set Wrap drive to ON position. Other drives set to default/OFF.

SINK/SOURCE Jumper Setting: SOURCE (All Drives)

Fuji Frenic Mini v.011

For use with Econolines with Keyence Nano PLC & Delta HMI

Job: 84271-100 Drive: 2 Motor: Top Trap

SETUP AND ADJUSTMENTS: (Reference Fuji drive manual for detailed information)

Set Primary Parameters:

Parameter	Fuji Default	Quadrel Default Value	Quadrel Final Value	Description
F01	4	0 (Keypad)	1 ✓	Freq. Command
F02	2	1 (Terminals)	1 ✓	Operation
F03*	60.0	60.0		Max Frequency
F07	6.0	3.0	3.0	Accel Time
F08	6.0	3.0	3.0	Decel Time
F15	70	70		Frequency Limit
F42	0	2	2 ✓	Control Mode
H30**	0	1	1 ✓	Comm Function
E27	99	0	0 ✓	Relay Function
P99	0	1 (HP)	1 ✓	Motor Type
P02	Varies	See Motor Nameplate	0.38	Rated Capacity (HP)
Y01***	1	1	1 (Conveyor Only) ✓	Drive Address
Y10	1	2	2 ✓	Protocol

*: If F03 needs to be greater than 70.0 (F15 Default), F15 must be changed first.

** : 1 for Conveyor or Three Roller Wrap. 0 for all others.

***: 1 for Conveyor, 2 for Three Roller Wrap

P02 Reference for frequently used motors:

3/8 HP: 0.38, 1/6 HP: 0.17

Initialize Parameters

- Navigate to Parameter H03
- Use the STOP and UP Arrow to change H03 to "2". Press the Func/Data button.
- "Save" will flash on the display. H03 will revert back to "0" once the parameters are automatically set.

Set the Motor Current based on the Motor Nameplate value. Entered as Amps.

Parameter	Fuji Default	Motor Nameplate	Quadrel Final value
P03	Varies	1.9	1.9

P03 Reference for frequently used motors:

3/8 HP: 1.9, 1/6 HP: 0.73

S03 Jumper Setting:

Default is in the OFF position.

Standard Systems: Set DR1 Conveyor to ON position. Other drives set to default/OFF.

Three Roller Systems: Set Wrap drive to ON position. Other drives set to default/OFF.

SINK/SOURCE Jumper Setting: SOURCE (All Drives)

Fuji Frenic Mini v.011

For use with Econolines with Keyence Nano PLC & Delta HMI

Job: 84271-100 Drive: 3 Motor: Chain aligners

SETUP AND ADJUSTMENTS: (Reference Fuji drive manual for detailed information)

Set Primary Parameters:

Parameter	Fuji Default	Quadrel Default Value	Quadrel Final Value	Description
F01	4	0 (Keypad)	1 ✓	Freq. Command
F02	2	1 (Terminals)	1 ✓	Operation
F03*	60.0	60.0		Max Frequency
F07	6.0	3.0	3.0	Accel Time
F08	6.0	3.0	3.0	Decel Time
F15	70	70		Frequency Limit
F42	0	2	2 ✓	Control Mode
H30**	0	1	10	Comm Function
E27	99	0	0 ✓	Relay Function
P99	0	1 (HP)	1 ✓	Motor Type
P02	Varies	See Motor Nameplate	.17	Rated Capacity (HP)
Y01***	1	1	1 (Conveyor Only) ✓	Drive Address
Y10	1	2	2 ✓	Protocol

*: If F03 needs to be greater than 70.0 (F15 Default), F15 must be changed first.

** : 1 for Conveyor or Three Roller Wrap. 0 for all others.

***: 1 for Conveyor, 2 for Three Roller Wrap

P02 Reference for frequently used motors:

3/8 HP: 0.38, 1/6 HP: 0.17

Initialize Parameters

- Navigate to Parameter H03
- Use the STOP and UP Arrow to change H03 to "2". Press the Func/Data button.
- "Save" will flash on the display. H03 will revert back to "0" once the parameters are automatically set.

Set the Motor Current based on the Motor Nameplate value. Entered as Amps.

Parameter	Fuji Default	Motor Nameplate	Quadrel Final value
P03	Varies	.73	.73

P03 Reference for frequently used motors:

3/8 HP: 1.9, 1/6 HP: 0.73

S03 Jumper Setting:

Default is in the OFF position.

Standard Systems: Set DR1 Conveyor to ON position. Other drives set to default/OFF.

Three Roller Systems: Set Wrap drive to ON position. Other drives set to default/OFF.

SINK/SOURCE Jumper Setting: SOURCE (All Drives)

WARNING



! WARNING

1. READ AND UNDERSTAND THE OPERATION MANUAL AND ALL SAFETY LABELS BEFORE OPERATING THIS MACHINE.
2. ONLY A TRAINED PERSON IS TO BE PERMITTED TO OPERATE THIS MACHINE. TRAINING SHOULD INCLUDE INSTRUCTION IN OPERATION UNDER NORMAL CONDITIONS AND EMERGENCY SITUATIONS.
3. THIS MACHINE IS TO BE SERVICED ONLY BY TRAINED AND AUTHORIZED PERSONNEL. FOLLOW LOCK-OUT PROCEDURES BEFORE SERVICING.
4. NEVER REACH INTO THE MACHINE FOR ANY REASON UNLESS THE MACHINE IS AT A COMPLETE STOP.
5. NEVER LEAVE THE MACHINE STOPPED IN SUCH A MANNER THAT ANOTHER WORKER CAN START THE MACHINE WHILE YOU ARE WORKING ON OR WITHIN THE MACHINE.
6. NEVER CHANGE OR DEFEAT THE FUNCTION OF ELECTRICAL INTERLOCKS OR OTHER MACHINE "SHUTDOWN" SWITCHES.
7. BEFORE STARTING THIS MACHINE, CHECK THAT: ALL PERSONS ARE CLEAR OF THE MACHINE; NO MAINTENANCE WORK IS BEING PERFORMED ON THE MACHINE, ALL GUARDS ARE IN PLACE.
8. ROUTINE INSPECTIONS AND CORRECTIVE/PREVENTATIVE MAINTENANCE MEASURES ARE TO BE CONDUCTED TO ENSURE THAT ALL GUARDS AND SAFETY FEATURES ARE RETAINED AND FUNCTION PROPERLY.

- KEEP HAND CLEAR OF MOVING PARTS. DO NOT PLACE HANDS NEAR LABELING HEAD WHEN IN OPERATION



- DO NOT OPERATE EQUIPMENT WITHOUT GUARDS OR COVERS INSTALLED



6.1 LABELING HEAD INFORMATION

6.1.1 LOADING AND UNLOADING STOCK ROLL

-  **CAUTION** To avoid injuries, you must keep the labeler stopped/paused. You can manually jog labels with the JOG button.

Look carefully at the diagram and follow the threading procedures indicated below.

You will also find the threading diagram directly on the labeling head.

- 1) Place the label stock roll on the unwind shaft. Press the roll firmly against the flange. Then slide the locking collar over the unwind shaft aligning the set screw with the shaft. Press into the roll and twist to lock the collar in place.



- 2) Pull Approximately 36-40" of stock from label stock roll.



- 3) Follow the threading diagram on the labeling head for routing the web.
- 4) Thread through the dancer to the peel plate.





- 5) Feed the label around the peel plate and under the pressure shoe if (if there is one). Feed the label up the head to the pull roll. Pull all the slack out.

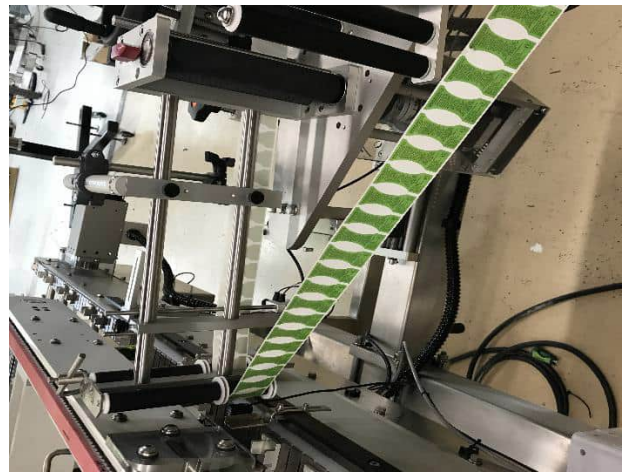
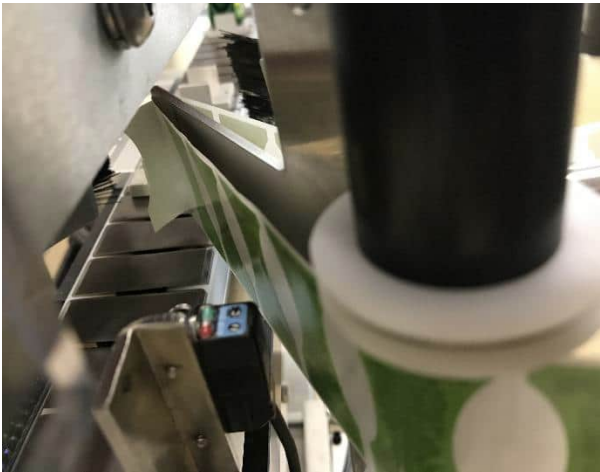

- 6) Wrap labels around the rubber roller as shown, then around the knurled roller. Make sure the knurled roller is not locked in by turning the red knob to the left or right of the red dot on the drive roll. When you have the labels completely threaded you can turn the knob to the red dot.

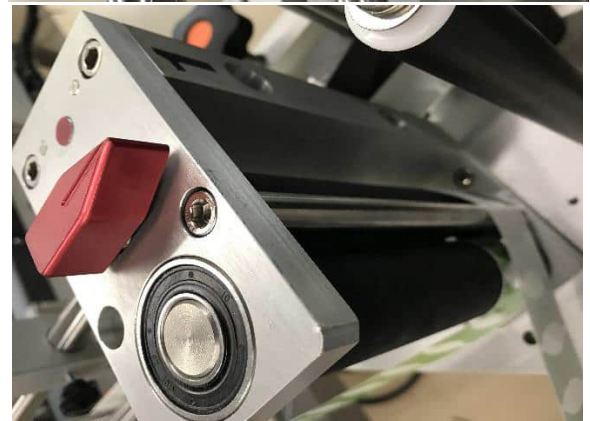
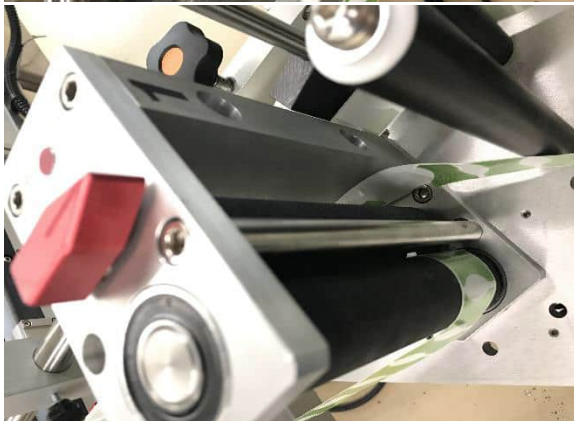
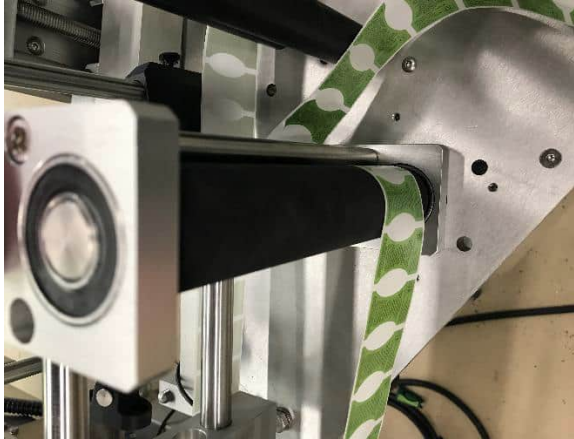

- 7) Thread the labels through the rewind dancers to the rewind shaft. Place the end of the label through the clip and rotate the rewind hub to take up the slack.



- 8) The finished product should look similar to the pictures below. Some heads are threaded differently depending on the style head you have. See threading diagrams on the head itself or the manual.

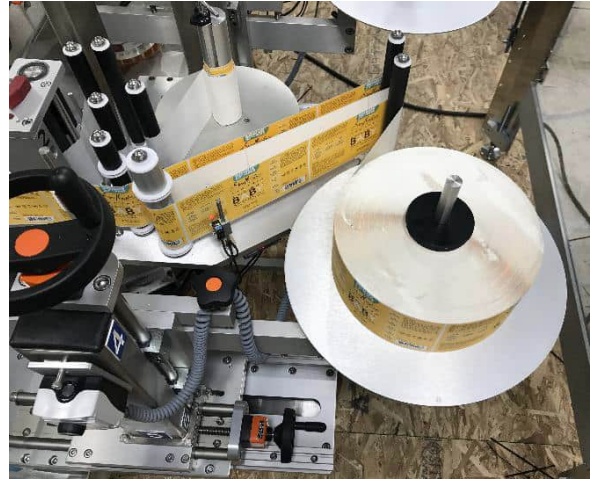

- 9) To unload the rewind loosen (counter clockwise) the “clevis” bolt on the top of the rewind hub. this will collapse the rewind and you can pull the liner off the hub.



CAUTION

There are many pinch points on a labeler. to avoid injury read and understand the owner’s manual before operating.

6.1.2 THREADING DIAGRAMS

Here are the following threading diagrams for our standard labeling heads.

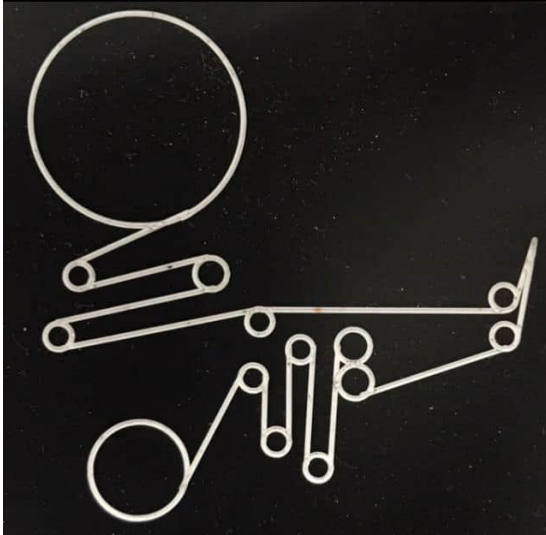

Q120/Q125/Q115/Q110

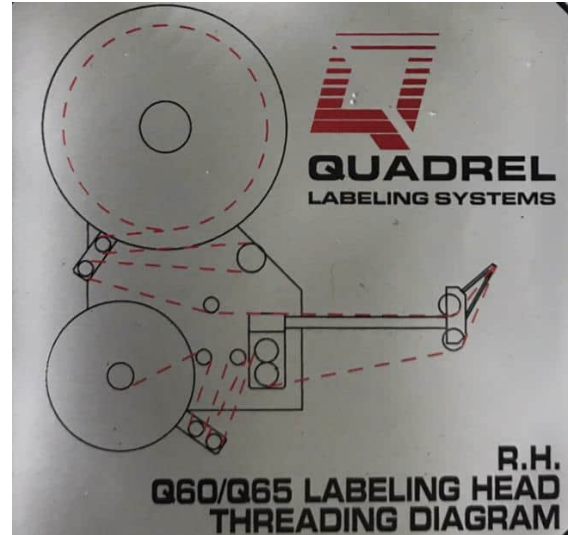

Q60/Q65

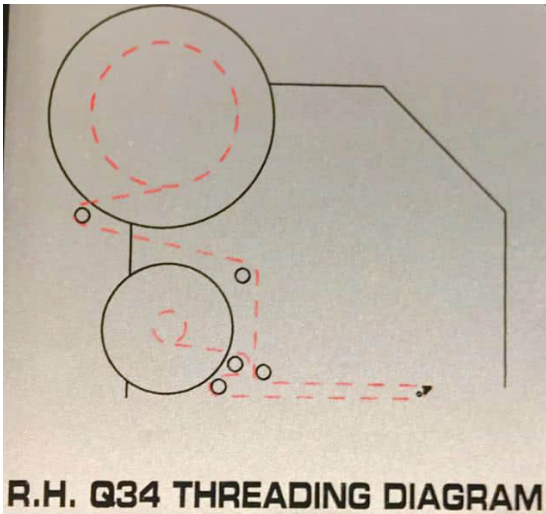

Q34

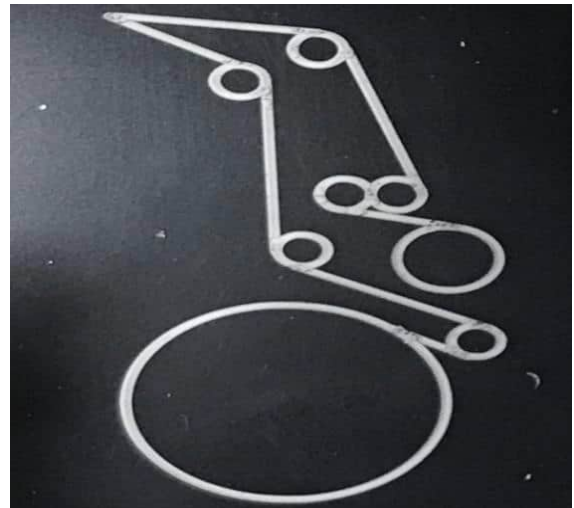

E100

6.1.3 LABELER ADJUSTMENTS

The vertical adjustment is to position the label on the container at different heights. It's practical if you have different size labels and/or containers. To adjust the height you simply rotate the handwheel at the top of the labeler counter clockwise to go down and clockwise to go up.



Horizontal adjustments are made the same way except you rotate the hand wheel under the labeler. Rotating the hand wheel counter clockwise will move the labeler in and rotating clockwise will move the labeler out.



To adjust the angle of the labeling head you first need to loosen the large $\frac{3}{4}$ -10 nut with a $1\frac{1}{4}$ " wrench and the $\frac{5}{16}$ -18 hex head bolt. The angular adjustment is very important to increase the repeatability of the process. A good adjustment is when the exit of the label is tangent with the surface of the application.



CAUTION

DO NOT remove the nut & bolt.



Now to adjust the tilt of the labeling head by tightening and loosening the jack screws.



Rotate adjustment is achieved by loosening the 2 ratchet handles under the labeling head. There is a jack screw holding the labeling head in place, but still use caution when loosening the ratchet handles the labeling head can rotate

freely when loose. This is a fine adjustment that increases the parallelism of the label to the shape of the container.



CAUTION

When loosening the labeling head, the head may rotate freely. Keep positive pressure against the head to prevent the head from rotating on its own.





ASSEMBLY TITLE: Q65 LABELING HEAD - BRAKE BRUSH ASSEMBLY

DRAWING NO: NONE

GENERAL FUNCTION:

- The brake brush establishes web tension and controls backlash

SET UP AND ADJUSTMENTS:

- For accurate label feeds, the web must establish proper tension.
- Loosen the holding set screw in the brake brush body. The brake brush assembly can now be rotated on axis.
- Turn brush body into the web and tighten. To check for proper web tension, jog a label and check for web slack. If the web is tight and the label feeds correctly, the brush tension is set correctly.
- If backlash persists, continue to increase brake brush tension.

MAINTENANCE:

- Replace brake brush when brush body contour no longer viable or bristles are worn down.

TROUBLESHOOTING:

PROBLEM

- Web break
- Motor stall
- Too much web slack

WHAT TO DO

- Too much brake tension. Decrease until no slack in web.
- Debris or brake flaw causing web tear
- Decrease brake tension
- Increase brake tension

ASSEMBLY TITLE:

LABELING HEAD - THREADING

GENERAL FUNCTION:

- This section is used to guide the user through loading and feeding the label through the web path.

SET UP AND ADJUSTMENTS:

- Load label spool onto unwind hub. Secure unwind retainer onto hub and lock. Pull 3'-4' of web from unwind and strip labels free of web.
- Unlock the drive roller locking handle.
- Using the threading diagram located on the labeling head, feed the web through the labeling head. Start at the unwind dancer assembly and work forward.
- Feed the web through the drive roller assembly.
- Feed the web around the rewind dancer assembly and onto the rewind hub. Wrap the web around the hub once. Lock the web in place with the rewind retaining bracket.
- Once the web has been threaded, lock down the drive roll assembly by rotating the drive roll locking arm into the locked position. (Towards the drive roller assembly)

MAINTENANCE:

- None this section.

TROUBLESHOOTING:

PROBLEM

- Web break

- No Web Tension

WHAT TO DO

- Check web path and insure web routed correctly.
- Debris causing web tear and break. Clear as needed.
- Check web path through unwind and dancer assembly.
- Check drive roller lock position.

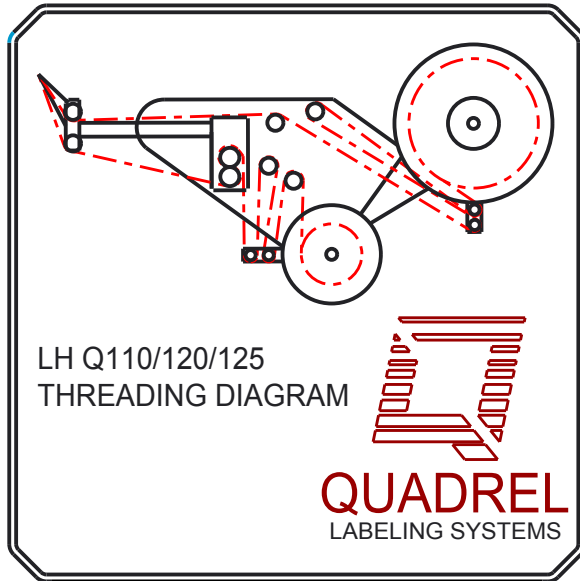

NOTES:

- 1) LABEL MATERIAL IS .003" ALUMINUM FOIL W/PERMANENT PRESSURE SENSITIVE ADHESIVE.
- 2) ALL LETTERING IS .125" HIGH EUROSTYLE 2, BOLD EXTENDED 2.
- 3) USE QUADREL STANDARD LOGO.
- 4) ALL LINES AND LETTERS ARE BLACK ON A SILVER BACKGROUND QUADREL AND (WEB PATH) ARE RED #(199c) LINES ARE DASHED LINES.
- 5) LABEL SIZE 3.0" X 3.0".

A	5-8-19	NEW DRAWING
REV	DATE	DESCRIPTION

THIS IS A PRO-ENGINEER DOCUMENT AND MAY NOT BE MODIFIED MANUALLY

UNLESS OTHERWISE SPECIFIED DIMENSIONAL TOLERANCE $X \pm .1$ $.XX \pm .01$ $.XXX \pm .005$ ANGLES $\pm 30'$ SURFACE FINISH 125 BREAK ALL EDGES .005/.015 CORNER RADIUS .010/.030	 QUADREL LABELING SYSTEMS 7670 JENTHER DRIVE MENTOR, OHIO 44060 (440) 602-4700	SCALE: DRAWING SCALE DATE: 5-8-19 DRW BY: TJS CHK BY: APPR BY:
	Q110/120/125 L.H. THREADING DIAGRAM	
MAT'L	SEE NOTES	A26222-110LH

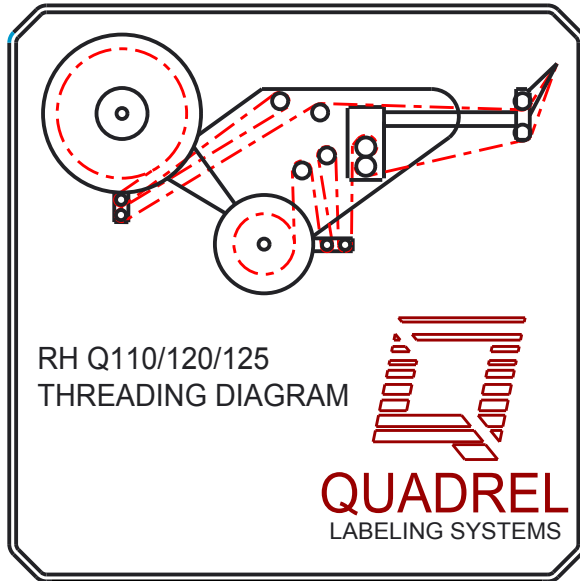

NOTES:

- 1) LABEL MATERIAL IS .003" ALUMINUM FOIL W/PERMANENT PRESSURE SENSITIVE ADHESIVE.
- 2) ALL LETTERING IS .125" HIGH EUROSTYLE 2, BOLD EXTENDED 2.
- 3) USE QUADREL STANDARD LOGO.
- 4) ALL LINES AND LETTERS ARE BLACK ON A SILVER BACKGROUND QUADREL AND (WEB PATH) ARE RED #(199c) LINES ARE DASHED LINES.
- 5) LABEL SIZE 3.0" X 3.0".

A	5-8-19	NEW DRAWING
REV	DATE	DESCRIPTION

THIS IS A PRO-ENGINEER DOCUMENT AND MAY NOT BE MODIFIED MANUALLY

UNLESS OTHERWISE SPECIFIED DIMENSIONAL TOLERANCE $X \pm .1$ $.XX \pm .01$ $.XXX \pm .005$ ANGLES $\pm 30'$ SURFACE FINISH 125 BREAK ALL EDGES .005/.015 CORNER RADIUS .010/.030	 QUADREL LABELING SYSTEMS 7670 JENTHER DRIVE MENTOR, OHIO 44060 (440) 602-4700	SCALE: DRAWING SCALE DATE: 5-8-19 DRW BY: TJS CHK BY: APPR BY:
	Q110/120/125 R.H. THREADING DIAGRAM	
MAT'L	SEE NOTES	A26222-110RH

ASSEMBLY TITLE: Q65 SIDE PLATE ASSEMBLY

DRAWING NO.: D24272-000

GENERAL FUNCTION:

- To provide a rigid mounting surface for outboard labeling components, electronic components, and system components.
- The side plate also supports the system mount

SET UP AND ADJUSTMENTS:

- None

MAINTENANCE:

- None

TROUBLESHOOTING:

- None



ITEM	QTY	PART NO.	DESCRIPTION	PARENT ITEM
1	2	00669-01	BRAKE BRUSH 2 x 7 nylon	23100SP-010RH
2	2	181062-000	BEARING, ROLL END	23100SP-010RH
3	6	181063-000	BEARING, ROLL END	23100SP-010RH
4	1	791459-000	RUBBER BUMPER	23100SP-010RH
5	1	A20654-001	ADJ. ROD	23100SP-010RH
6	3	A20928-000	ROLLER SHAFT	23100SP-010RH
7	1	A21259-004	IDLER ROLLER	23100SP-010RH
8	1	A21618-002	IDLER SHAFT	23100SP-010RH
9	3	B20071-011	IDLER ROLLER (DANCER)	23100SP-010RH
10	1	D22800-120_REVC	SIDE PLATE, MOD.	23100SP-010RH

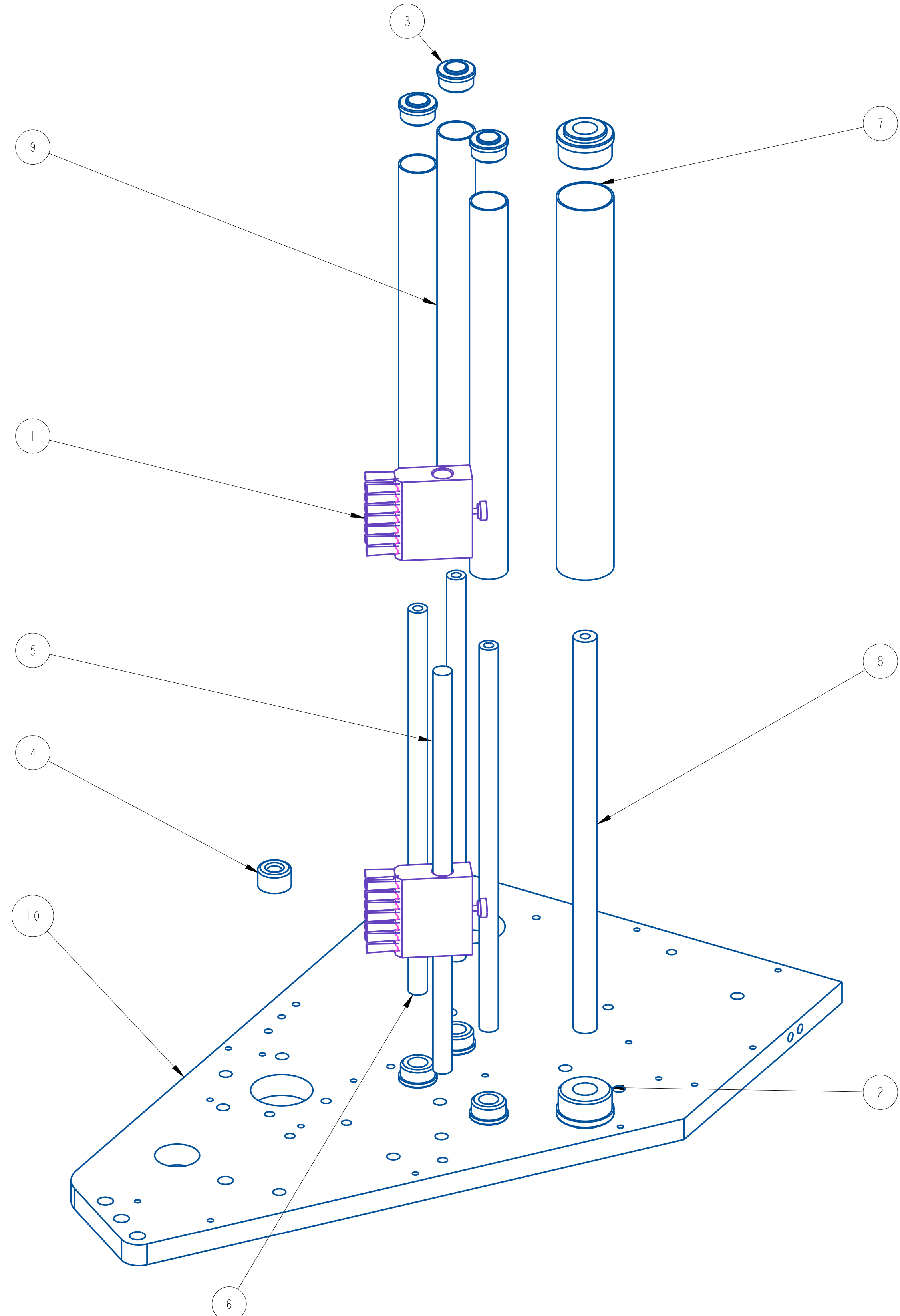

REV	DATE	DESCRIPTION	BY
A	Oct-01-25	NEW DRAWING	RDL

THIS IS A PRO-ENGINEER DOCUMENT AND MAY NOT BE MODIFIED MANUALLY

UNLESS OTHERWISE SPECIFIED DIMENSIONAL TOLERANCE .1 .01 .005 ANGLES ± 30° SURFACE FINISH 125 BREAK ALL EDGES .005/.015 CORNER RADIUS .010/.030	7670 JENTHER DRIVE MENTOR, OHIO 44060 (440) 602-4700	SCALE: 1/2
		DATE: Oct-01-25
		DRW BY: RDL
		CHK BY: RDL
10" SIDE PLATE ASSEMBLY, RHH		MAT'L
		23100SP-010RH

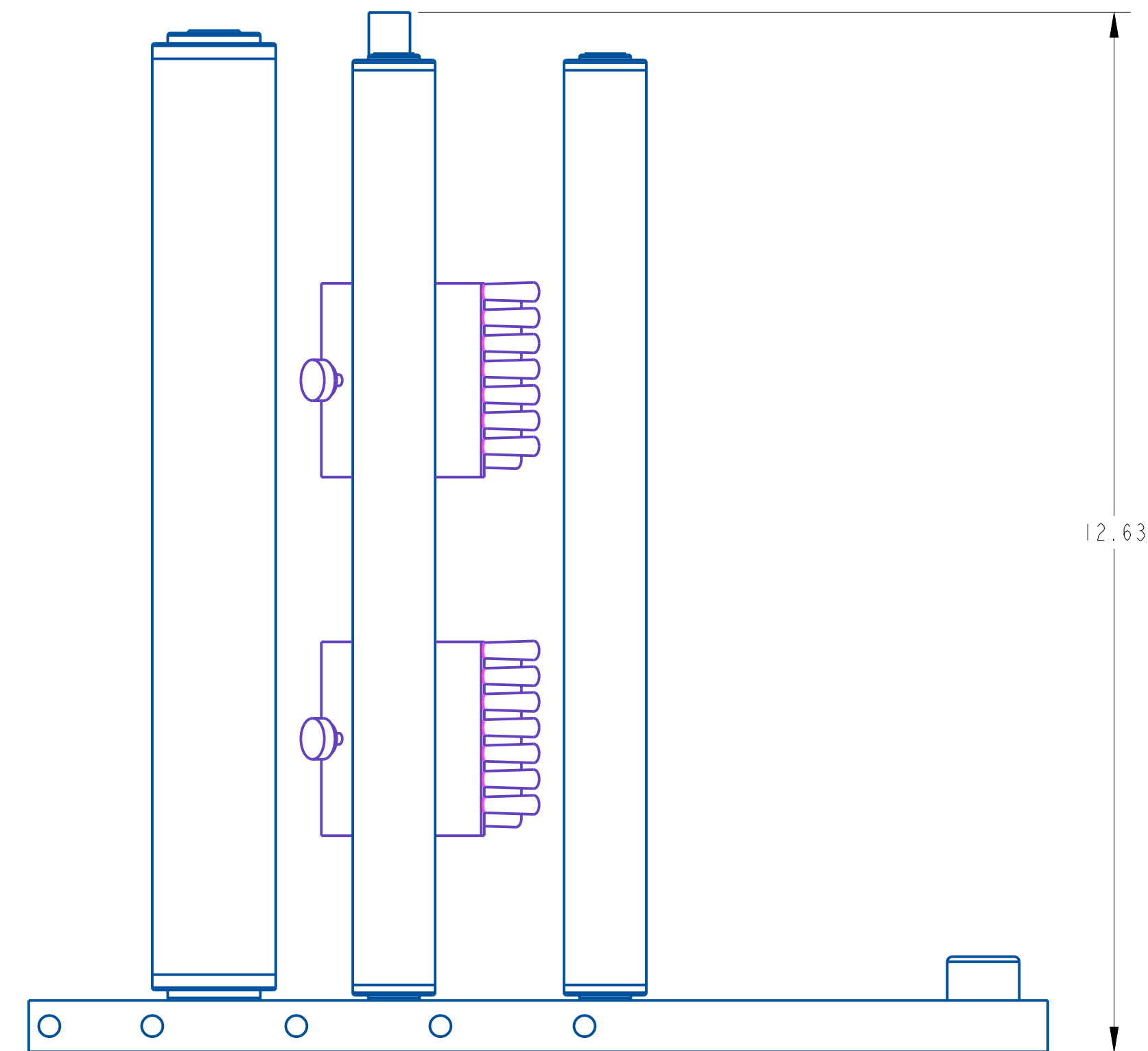
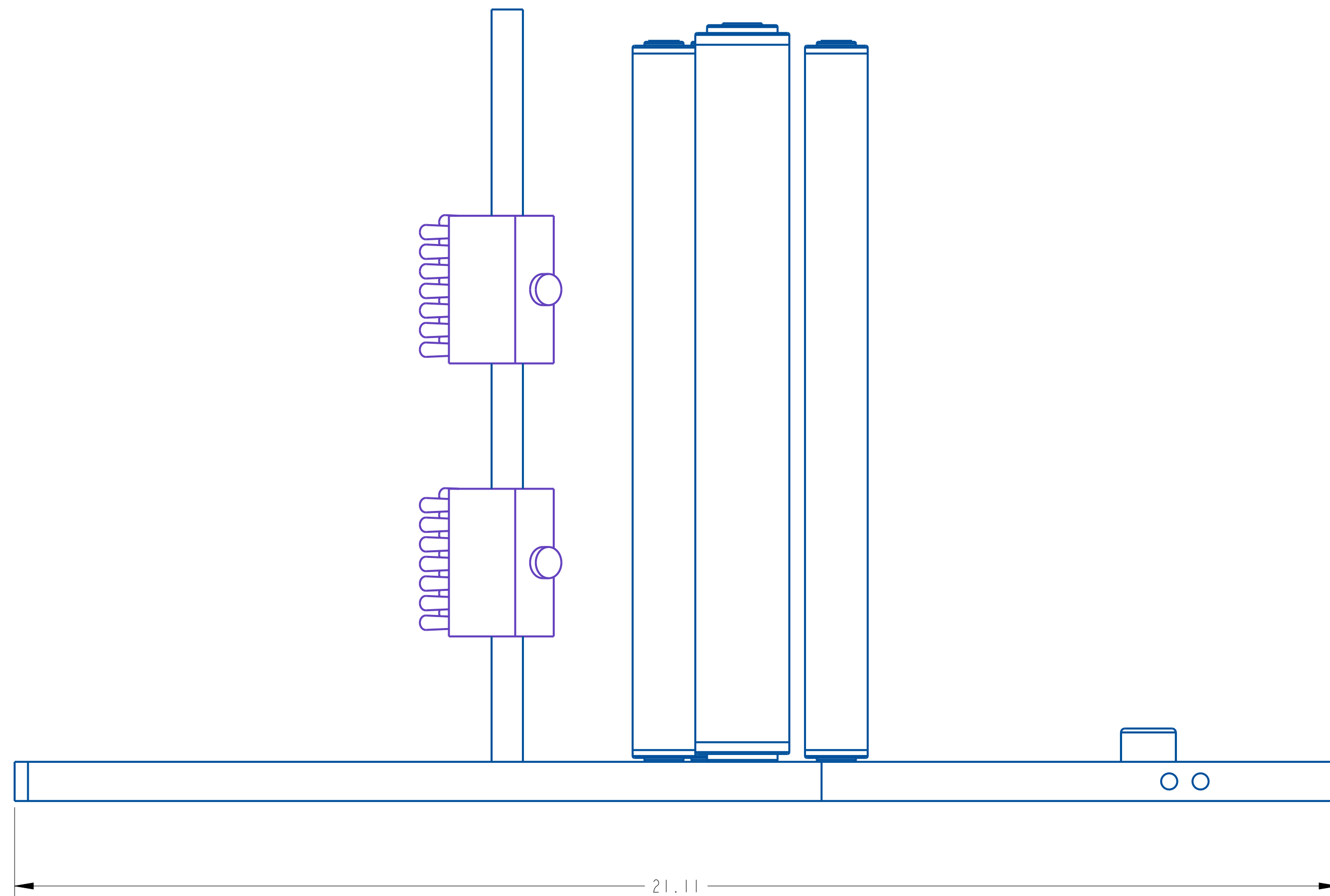
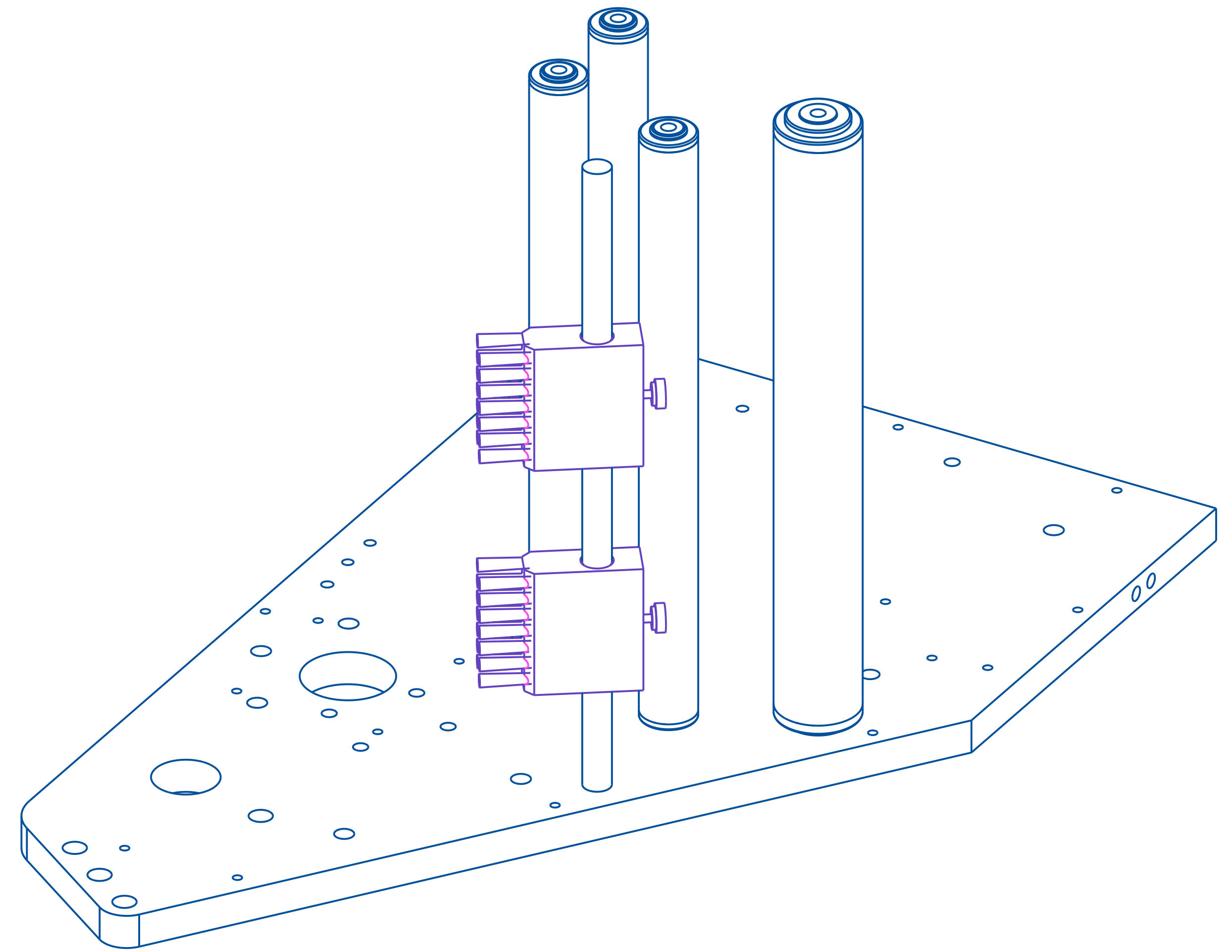
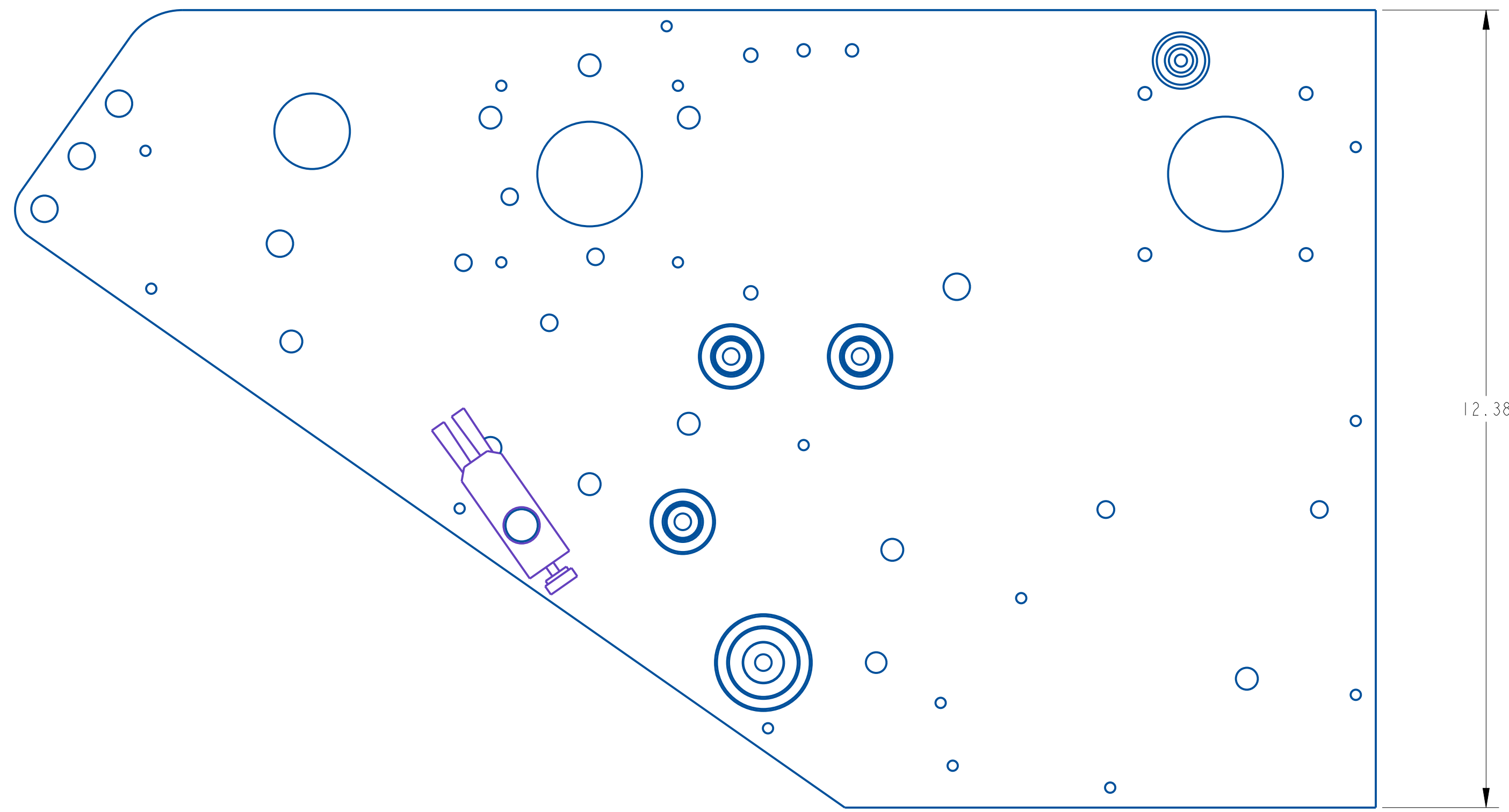

REV	DATE	DESCRIPTION	BY
A	0c1-01-25	NEW DRAWING	RDL

THIS IS A PRO-ENGINEER DOCUMENT AND MAY NOT BE MODIFIED MANUALLY

UNLESS OTHERWISE SPECIFIED
DIMENSIONAL TOLERANCE
X ± .1
XX ± .01
XXX ± .005
ANGLES ± .30°
SURFACE FINISH 125
BREAK ALL EDGES .005/ .015
CORNER RADIUS .010/ .030
ALL ANGLES ARE 90°

QUADREL LABELING SYSTEMS
7670 JENTHER DRIVE
MENTOR, OHIO 44060
(440) 602-4700
SCALE: 5/8
DATE: 0c1-01-25
DRW BY: RDL
CHK BY:
APPR BY:
10" SIDE PLATE ASSEMBLY, RHH
MAT'L
23100SP-010RH

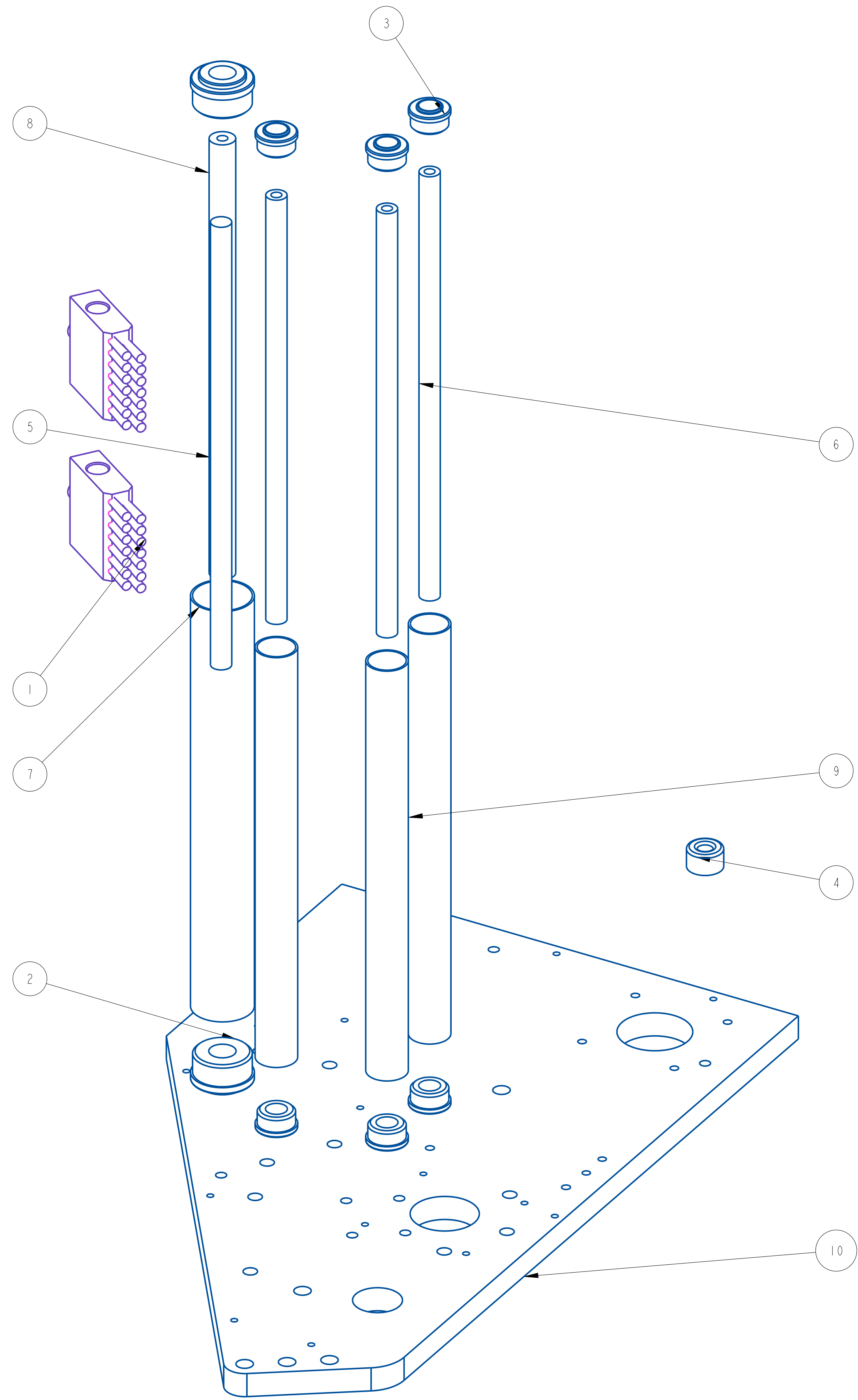

ITEM	QTY	PART NO.	DESCRIPTION	PARENT ITEM
1	2	00669-01	BRAKE BRUSH 2 x 7 nylon	23100SP-010LH
2	2	181062-000	BEARING, ROLL END	23100SP-010LH
3	6	181063-000	BEARING, ROLL END	23100SP-010LH
4	1	791459-000	RUBBER BUMPER	23100SP-010LH
5	1	A20654-001	ADJ. ROD	23100SP-010LH
6	3	A20928-000	ROLLER SHAFT	23100SP-010LH
7	1	A21259-004	IDLER ROLLER	23100SP-010LH
8	1	A21618-002	IDLER SHAFT	23100SP-010LH
9	3	B20071-011	IDLER ROLLER (DANCER)	23100SP-010LH
10	1	D22800-120_REVC	SIDE PLATE, MOD.	23100SP-010LH

REV	DATE	DESCRIPTION	BY
A	Oct-06-25	NEW DRAWING	RDL

THIS IS A PRO-ENGINEER DOCUMENT AND MAY NOT BE MODIFIED MANUALLY

UNLESS OTHERWISE SPECIFIED DIMENSIONAL TOLERANCE .XX ± .01 .XXX ± .005 ANGLES ± 30° SURFACE FINISH 125 BREAK ALL EDGES .005/0.15 CORNER RADIUS .010/0.30	QUADREL LABELING SYSTEMS 7670 JENTHER DRIVE MENTOR, OHIO 44060 (440) 602-4700	SCALE: 9/16 DATE: Oct-06-25 DRW BY: RDL CHK BY: APPR BY:
10" SIDE PLATE ASSEMBLY, LHH		MAT'L 23100SP-010LH

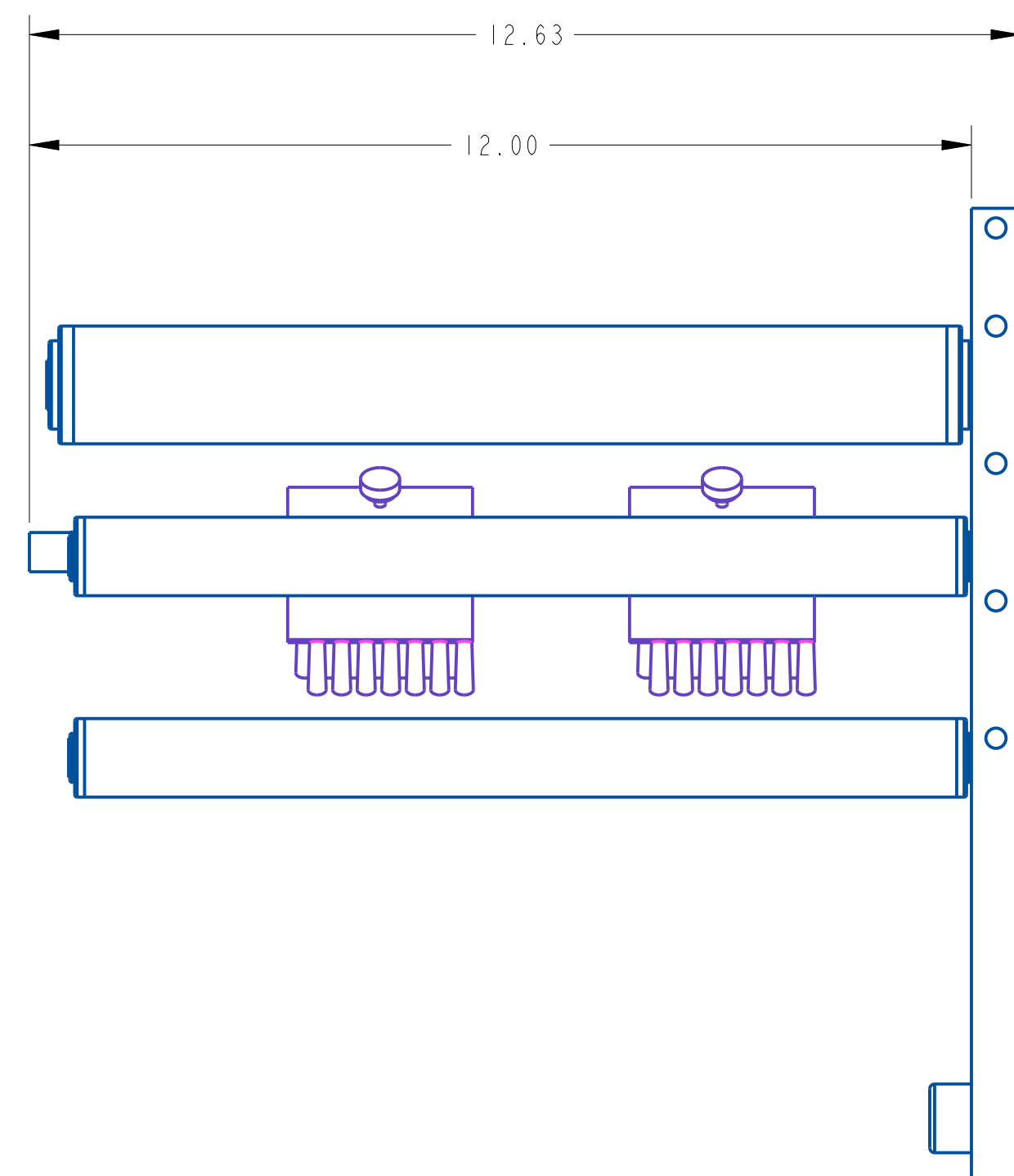
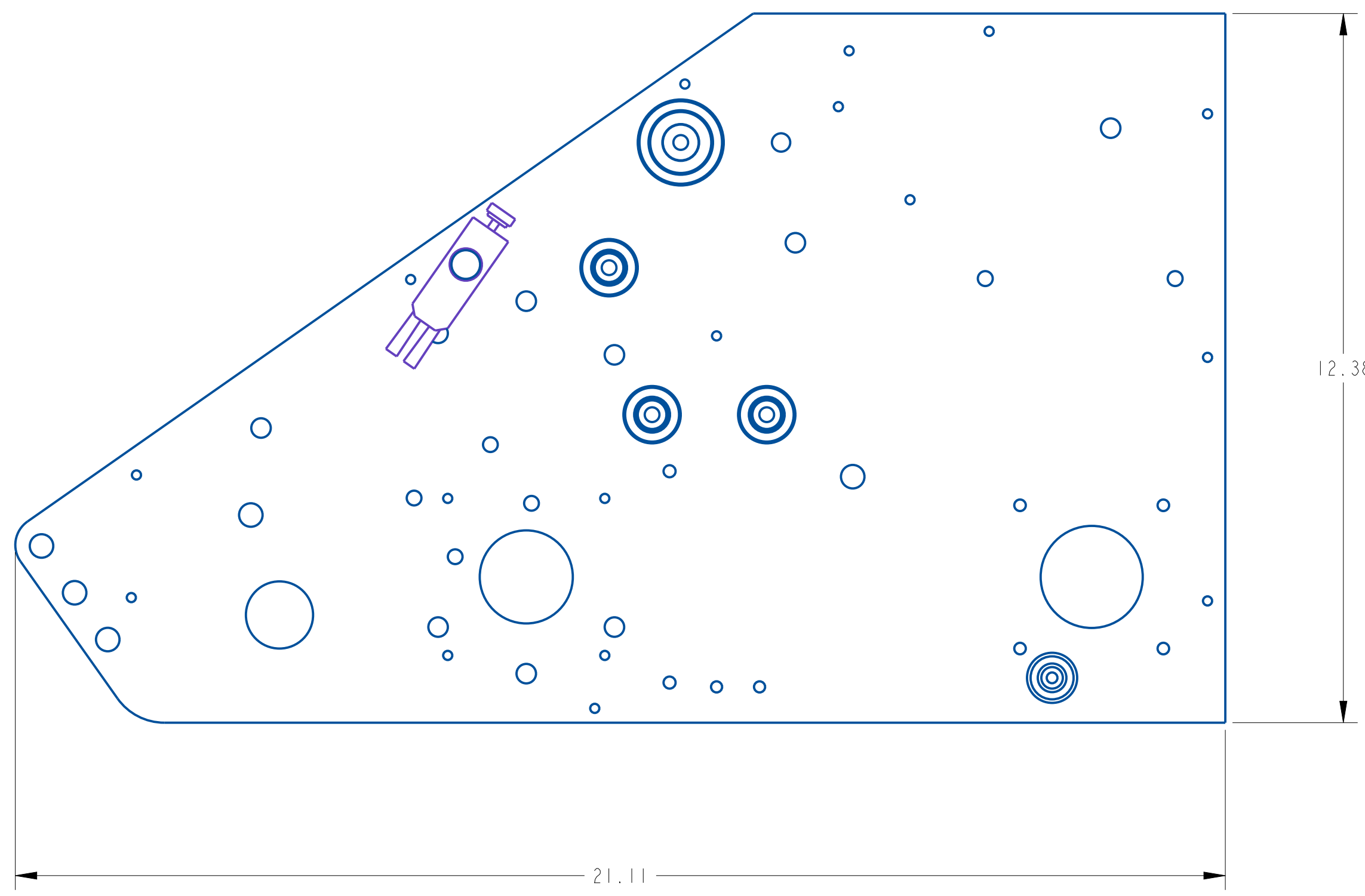
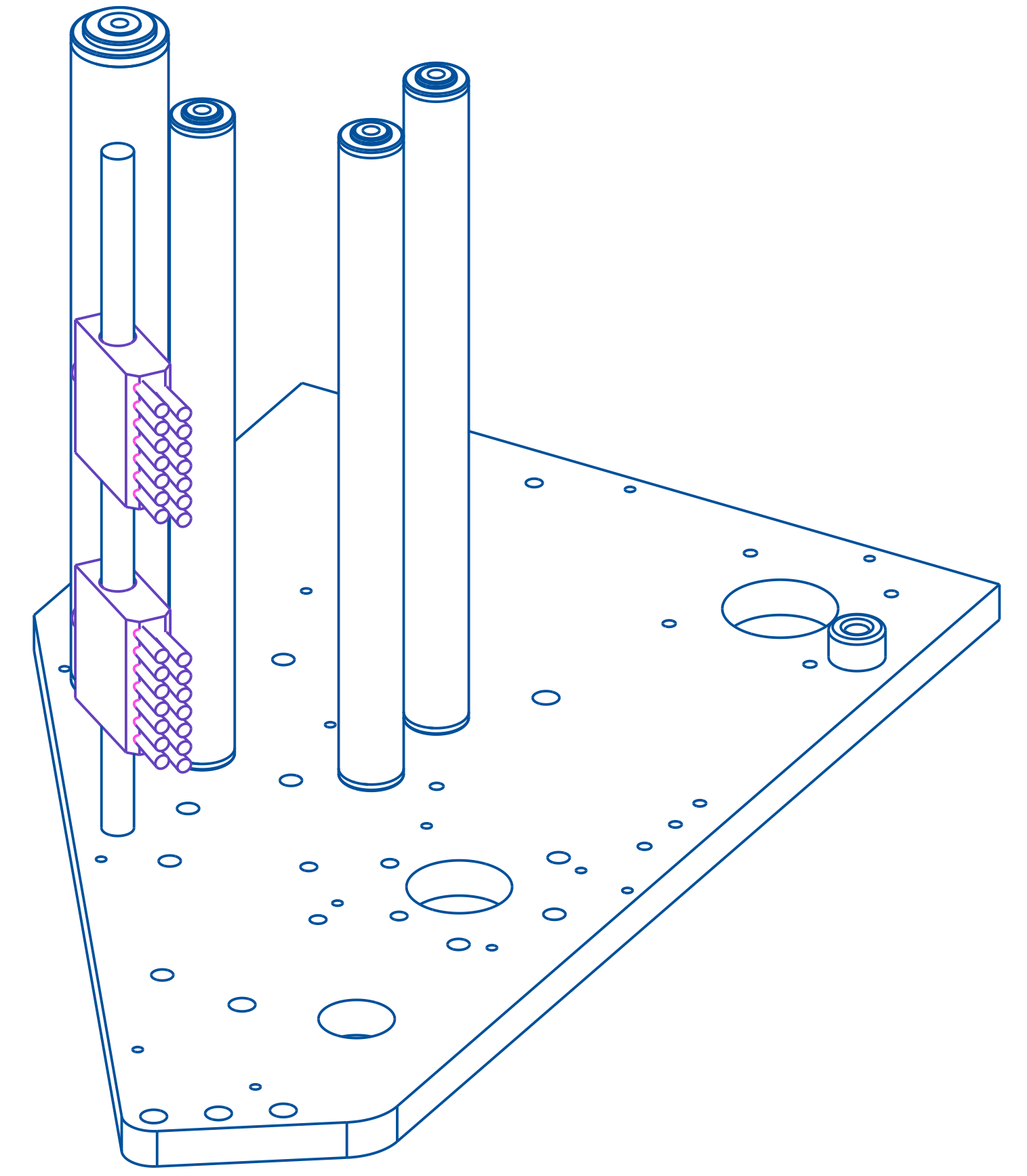
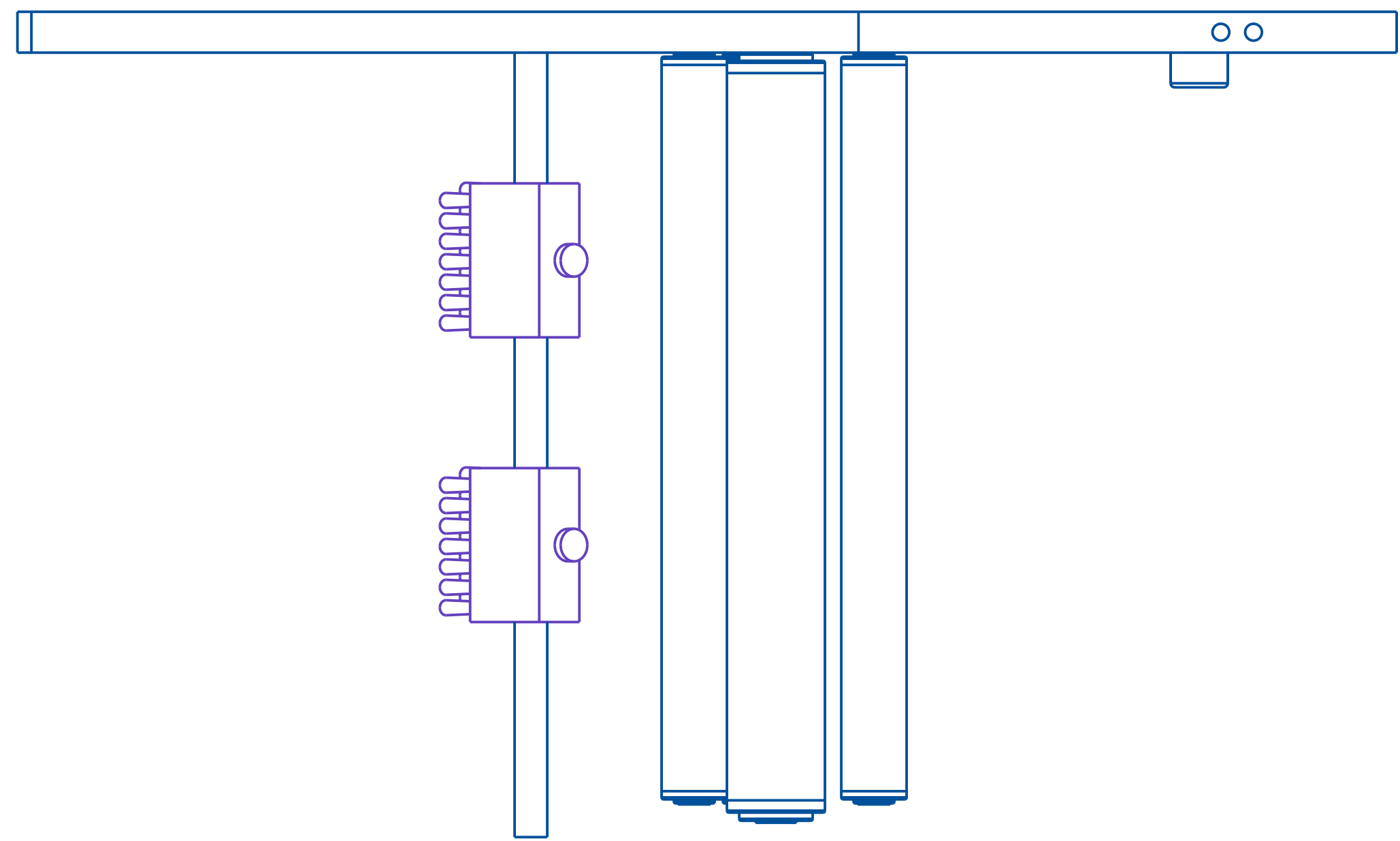

THIS IS A PRO-ENGINEER DOCUMENT AND MAY NOT BE MODIFIED MANUALLY

A	0ct-06-25	NEW DRAWING	RDL
REV	DATE	DESCRIPTION	BY

UNLESS OTHERWISE SPECIFIED
 DIMENSIONAL TOLERANCE
 .x ± .1
 .xx ± .01
 .xxx ± .005
 ANGLES ± .30°
 SURFACE FINISH 125
 BREAK ALL EDGES .005/.015
 CORNER RADIUS .010/.030
 ALL ANGLES ARE 90°

QUADREL LABELING SYSTEMS
 7670 JENTHER DRIVE
 MENTOR, OHIO 44060
 (440) 602-4700

SCALE: 1/2
 DATE: 0ct-06-25
 DRW BY: RDL
 CHK BY:
 APPR BY:

10" SIDE PLATE ASSEMBLY, LHH
 MAT'L
 23100SP-010LH

ASSEMBLY TITLE: Q65 7" UNWIND ASSEMBLY

DRAWING NO.: D21434-000

GENERAL FUNCTION:

- Unwind flange provides support for label rolls (side application)
- Dual flanges prevent roll and label movement (top application)
- Dancer arm prevents roll run-away.
- Idler roller with guide collars guides web through slot sensor.
- Brake brush prevents web buckling through slot sensor.

SET UP AND ADJUSTMENTS:

- Move flange to required height and tighten set screw in flange hub.
- For top labeling, add second flange and tighten ratchet knob.
- Adjust dancer tension by turning check nut so that dancer roll snaps back to braking position when labeling head is threaded.
- Slide brake brush so that center of brush lines up with center of web.
- Rotate brush to provide web tension, then lock into place using the locking knob.
- Position guide collars on idler roll, one slightly above, the other slightly below the web.

DANCER TENSION ADJUSTMENT LOCATION:

- **The unwind tension adjustment is located on the middle underside of the Q65 head. Use the knurled ring to adjust the dancer tension.**

MAINTENANCE:

- Clean all the parts that may acquire glue residue

TROUBLESHOOTING:

PROBLEM

- Unwind roll run-away
- Unwind roll not stopping
- Drive roll stalling
- Brush taking fixed shape

WHAT TO DO

- Tighten dancer spring, check nut or replace dancer spring, if necessary.
- Replace brake ring-belt if broken, or unevenly worn.
- Release web tension produced by brake brush.
- Turn brush around



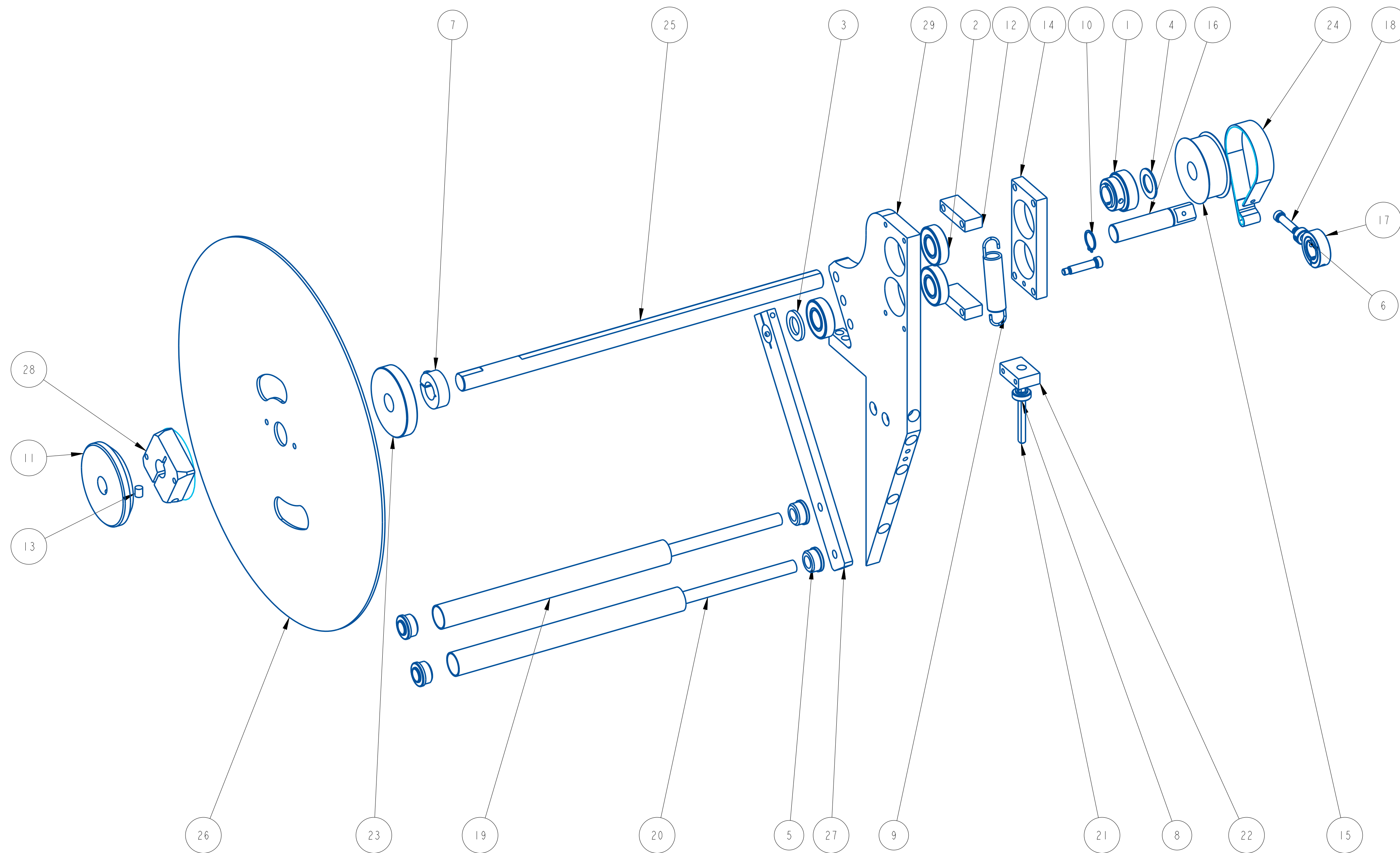

ITEM	QTY	PART NO.	DESCRIPTION	PARENT ITEM
1	1	111044-000	BEARING, 3/4 ID CLAMP TYPE	23100U-010LH
2	3	111074-000	BEARING, BALL	23100U-010LH
3	1	151001-000	BEARING, THRUST WASHER	23100U-010LH
4	1	151006-000	BEARING, THRUST WASHER	23100U-010LH
5	4	181063-000	BEARING, ROLL END	23100U-010LH
6	1	361165-000	COLLAR, SETSCREW, 5/16" BORE	23100U-010LH
7	1	361183-000	COLLAR, 3/4 ID ONE PIECE- S.S.	23100U-010LH
8	1	801601-000	CHECK NUT	23100U-010LH
9	1	811216-000	EXTENSION SPRING, STAINLESS	23100U-010LH
10	1	871025-000	EXTERNAL SNAP RING	23100U-010LH
11	1	A20583-000	QUICK LOCK COLLAR REWORK	23100U-010LH
12	2	A20585-000	SUPPORT SPACER	23100U-010LH
13	1	A20586-000	WHITE NYLON SLUG	23100U-010LH
14	1	A20590-000	BEARING PLATE	23100U-010LH
15	1	A20591-000	UNWIND BRAKE DRUM	23100U-010LH
16	1	A20592-200	UNWIND DANCER SHAFT	23100U-010LH
17	1	A20595-000	DANCER COLLAR	23100U-010LH
18	2	A20596-000	DANCER BOLT	23100U-010LH
19	2	A20931-000	IDLER ROLLER TUBE 12"	23100U-010LH
20	2	A20932-000	DANCER ROLL SHAFT 12"	23100U-010LH
21	1	A23131-000	STUD	23100U-010LH
22	1	A23298-000	BLOCK, SPRING TENSION	23100U-010LH
23	1	A23406-000	SUPPLY REEL CENTER HUB	23100U-010LH
24	1	A25825_000	BRAKE BAND	23100U-010LH
25	1	B20345-000	UNWIND SHAFT 12.50"	23100U-010LH
26	1	B20980-001	UNWIND FLANGE	23100U-010LH
27	1	B21113-000	DANCER ARM, 16" UNWIND	23100U-010LH
28	1	B21931-001	CORE HUB	23100U-010LH
29	1	C21236-120	UNWIND SUPPORT PLATE	23100U-010LH

REV	DATE	DESCRIPTION	BY
A	10/16/25	NEW DRAWING	SEM

THIS IS A PRO-ENGINEER DOCUMENT AND MAY NOT BE MODIFIED MANUALLY

UNLESS OTHERWISE SPECIFIED
DIMENSIONAL TOLERANCE

.X ± .1
 .XX ± .01
 .XXX ± .005
 ANGLES ± .30°

SURFACE FINISH 125
BREAK ALL EDGES .005/.015
CORNER RADIUS .010/.030
ALL ANGLES ARE 90°

QUADREL LABELING SYSTEMS
 7670 JENTHER DRIVE
 MENTOR, OHIO 44060
 (440) 602-4700

SCALE: 3/8
 DATE: 10/16/25
 DRW BY: SEM
 CHK BY: SEM
 APPR BY:

10" UNWIND ASSEMBLY

MAT'L

23100U-010LH

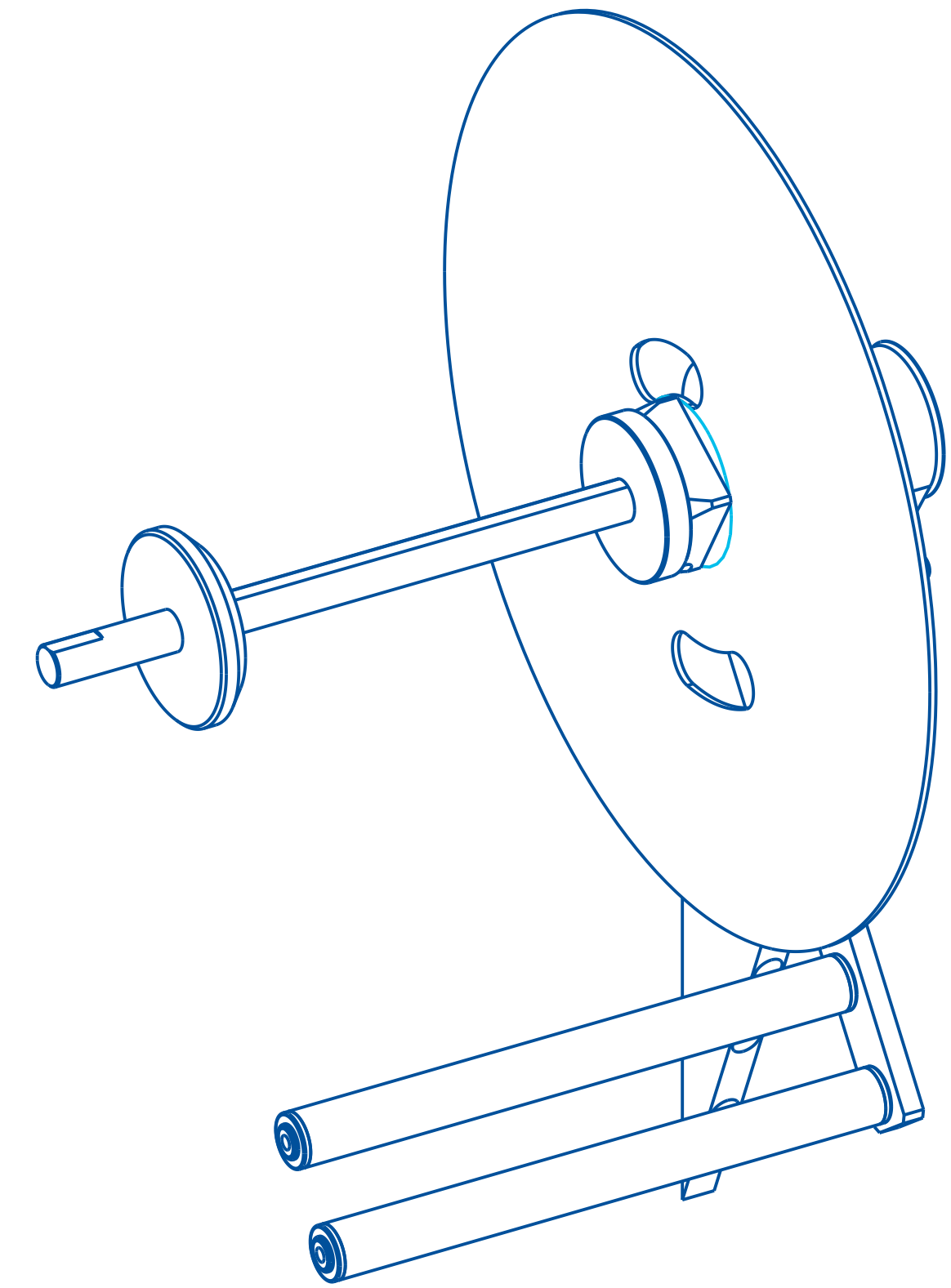
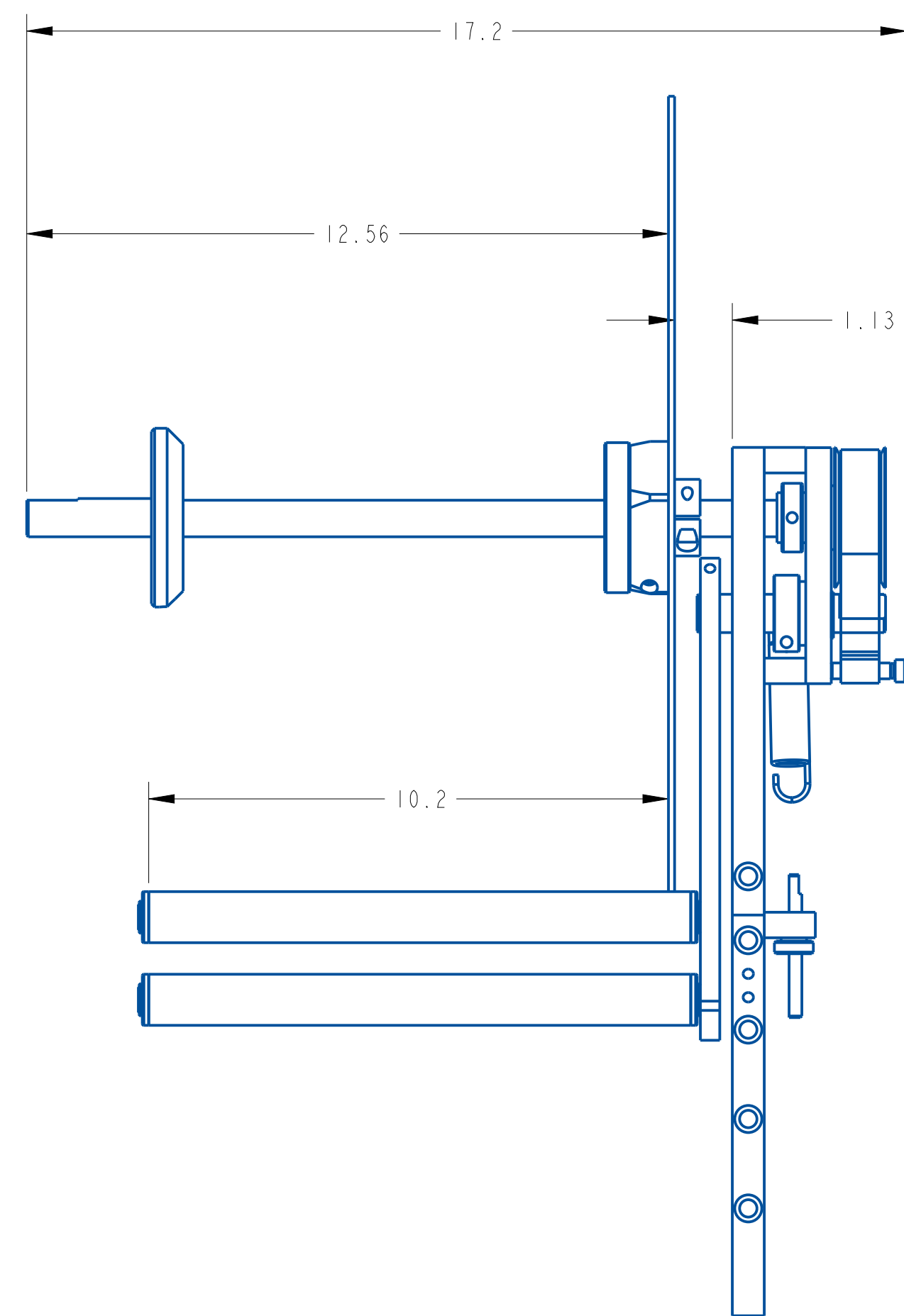
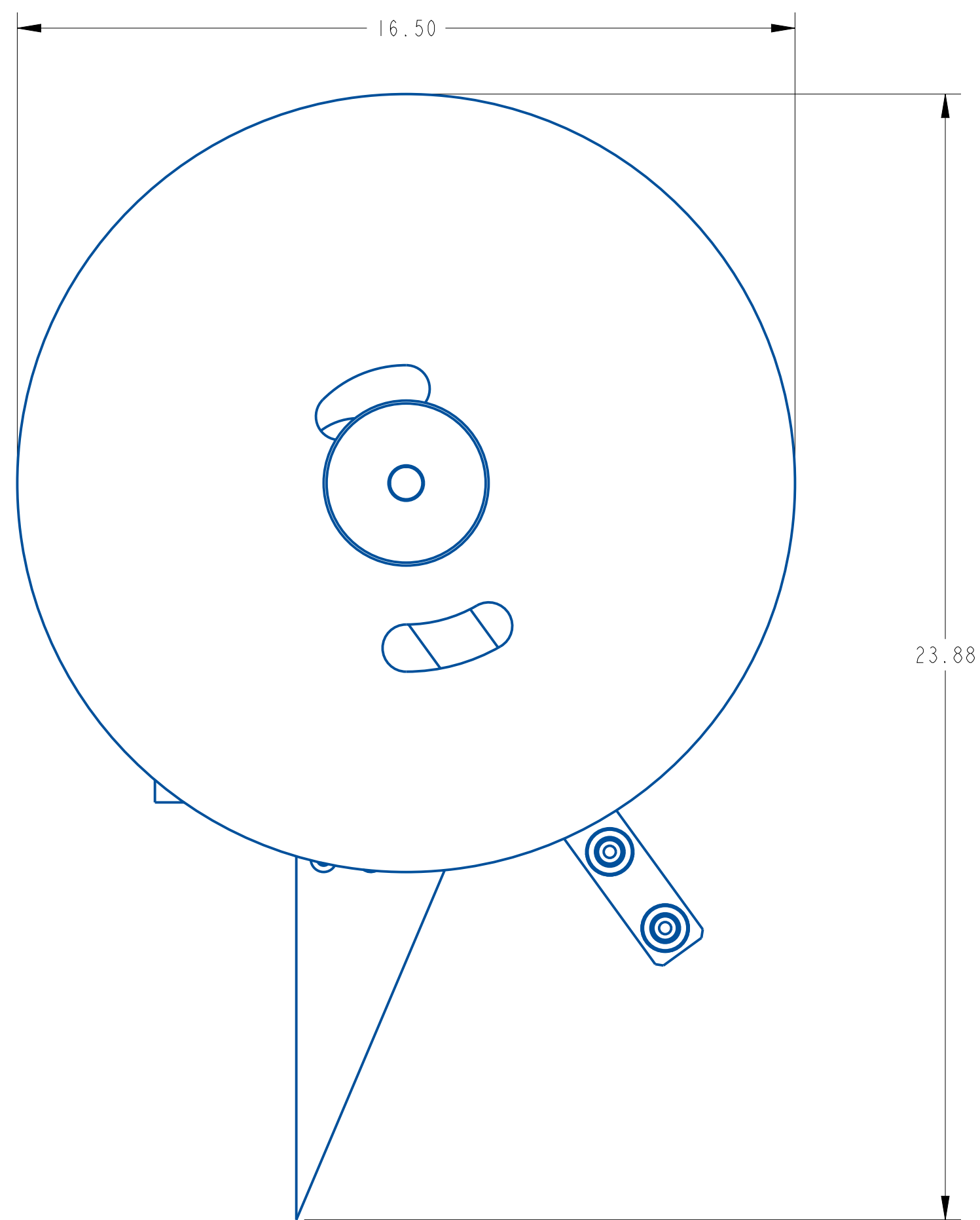
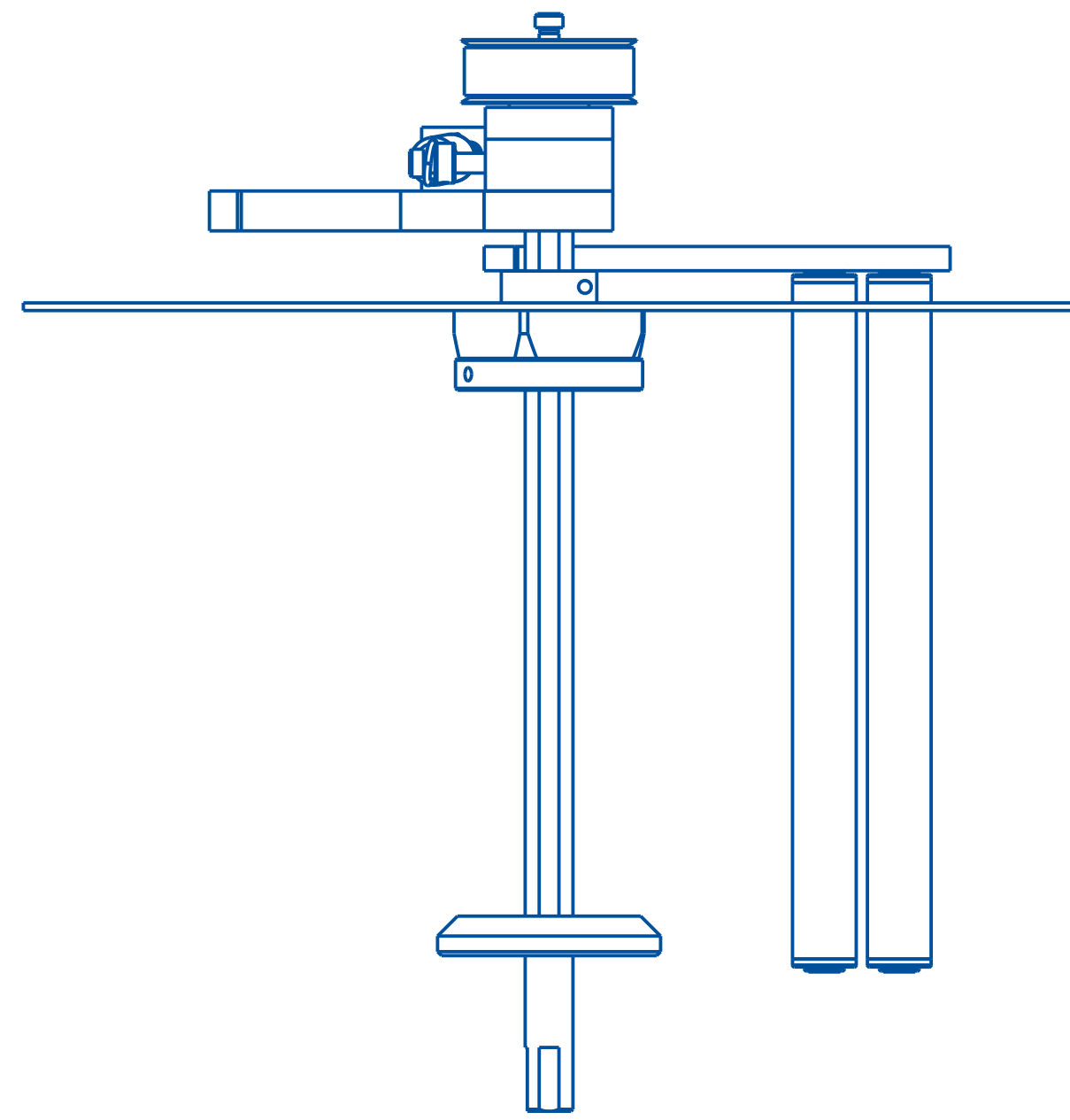

REV	DATE	DESCRIPTION	BYE
A	10/16/25	NEW DRAWING	SEM

THIS IS A PRO-ENGINEER DOCUMENT AND MAY NOT BE MODIFIED MANUALLY

UNLESS OTHERWISE SPECIFIED
DIMENSIONAL TOLERANCE
X ± .1
XX ± .01
XXX ± .005
ANGLES ± .30°
SURFACE FINISH 125
BREAK ALL EDGES .005/ .015
CORNER RADIUS .010/ .030
ALL ANGLES ARE 90°

QUADREL LABELING SYSTEMS
7670 JENTHER DRIVE
MENTOR, OHIO 44060
(440) 602-4700

SCALE: 3/8
DATE: 10/16/25
DRW BY: SEM
CHK BY: SEM
APPR BY:
10" UNWIND ASSEMBLY
MAT'L
23100U-010LH

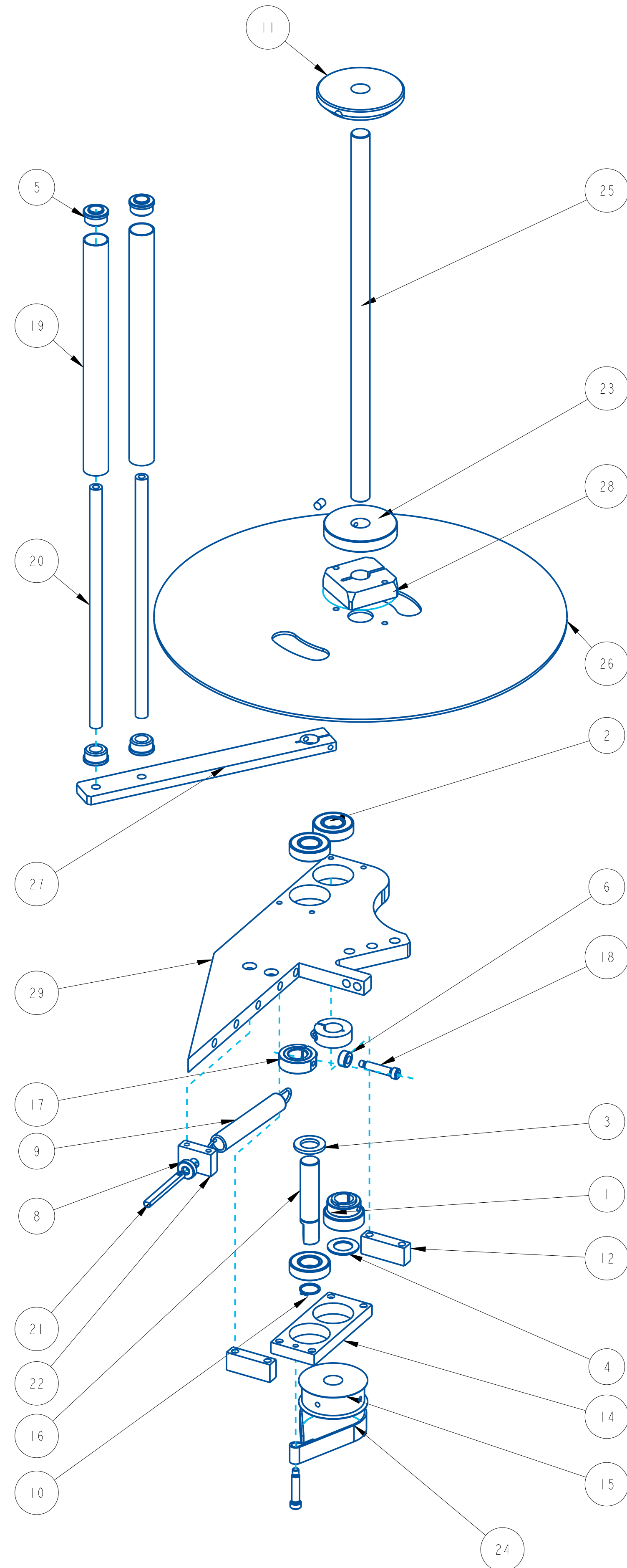

ITEM	QTY	PART NO.	DESCRIPTION	PARENT ITEM
1	1	111044-000	BEARING, 3/4 ID CLAMP TYPE	23100U-010RH
2	3	111074-000	BEARING, BALL	23100U-010RH
3	1	151001-000	BEARING, THRUST WASHER	23100U-010RH
4	1	151006-000	BEARING, THRUST WASHER	23100U-010RH
5	4	181063-000	BEARING, ROLL END	23100U-010RH
6	1	361165-000	COLLAR, SETSCREW, 5/16" BORE	23100U-010RH
7	1	361183-000	COLLAR, 3/4 ID ONE PIECE- S.S.	23100U-010RH
8	1	801601-000	CHECK NUT	23100U-010RH
9	1	811216-000	EXTENSION SPRING, STAINLESS	23100U-010RH
10	1	871025-000	EXTERNAL SNAP RING	23100U-010RH
11	1	A20583-000	QUICK LOCK COLLAR REWORK	23100U-010RH
12	2	A20585-000	SUPPORT SPACER	23100U-010RH
13	1	A20586-000	WHITE NYLON SLUG	23100U-010RH
14	1	A20590-000	BEARING PLATE	23100U-010RH
15	1	A20591-000	UNWIND BRAKE DRUM	23100U-010RH
16	1	A20592-200	UNWIND DANCER SHAFT	23100U-010RH
17	1	A20595-000	DANCER COLLAR	23100U-010RH
18	2	A20596-000	DANCER BOLT	23100U-010RH
19	2	A20931-000	IDLER ROLLER TUBE 12"	23100U-010RH
20	2	A20932-000	DANCER ROLL SHAFT 12"	23100U-010RH
21	1	A23131-000	STUD	23100U-010RH
22	1	A23298-000	BLOCK, SPRING TENSION	23100U-010RH
23	1	A23406-000	SUPPLY REEL CENTER HUB	23100U-010RH
24	1	A25825-000_22620	BRAKE BAND	23100U-010RH
25	1	B20345-000	UNWIND SHAFT 12.50"	23100U-010RH
26	1	B20980-001	UNWIND FLANGE	23100U-010RH
27	1	B21113-000	DANCER ARM, 16" UNWIND	23100U-010RH
28	1	B21931-001	CORE HUB	23100U-010RH
29	1	C21236-120	UNWIND SUPPORT PLATE	23100U-010RH

REV	DATE	DESCRIPTION	BY
A	Oct-13-25	NEW DRAWING	RDL

THIS IS A PRO-ENGINEER DOCUMENT AND MAY NOT BE MODIFIED MANUALLY

UNLESS OTHERWISE SPECIFIED
 DIMENSIONAL TOLERANCE
 .XX ± .01
 .XXX ± .005
 ANGLES ± 30°

SCALE: 5/16
 DATE: Oct-13-25
 DRW BY: RDL
 CHK BY:
 APPR BY:

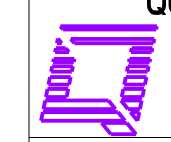

QUADREL LABELING SYSTEMS
 7670 JENTHER DRIVE
 MENTOR, OHIO 44060
 (440) 602-4700

10" UNWIND ASSEMBLY

MAT'L	DESCRIPTION	QTY
	23100U-010RH	

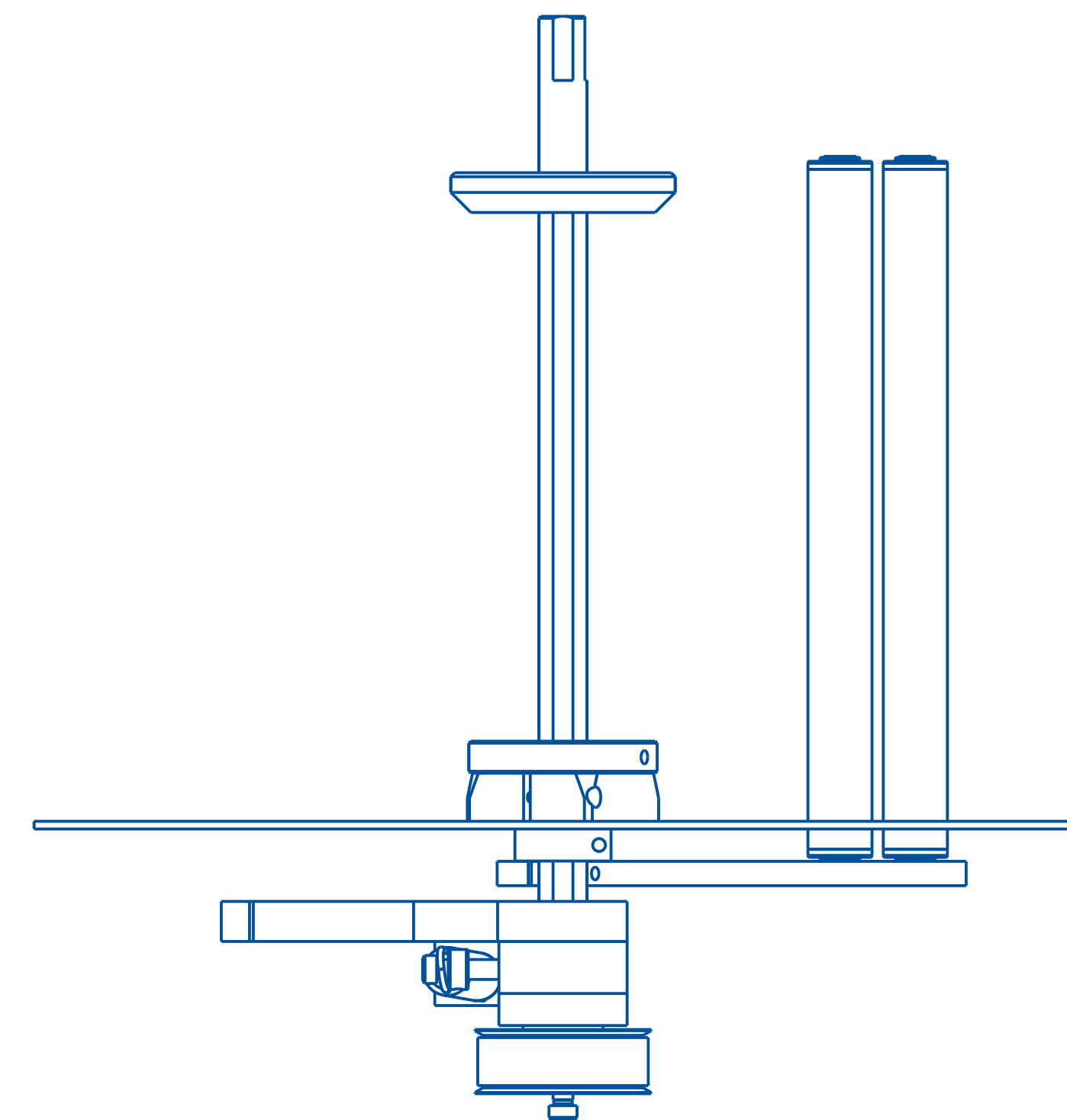
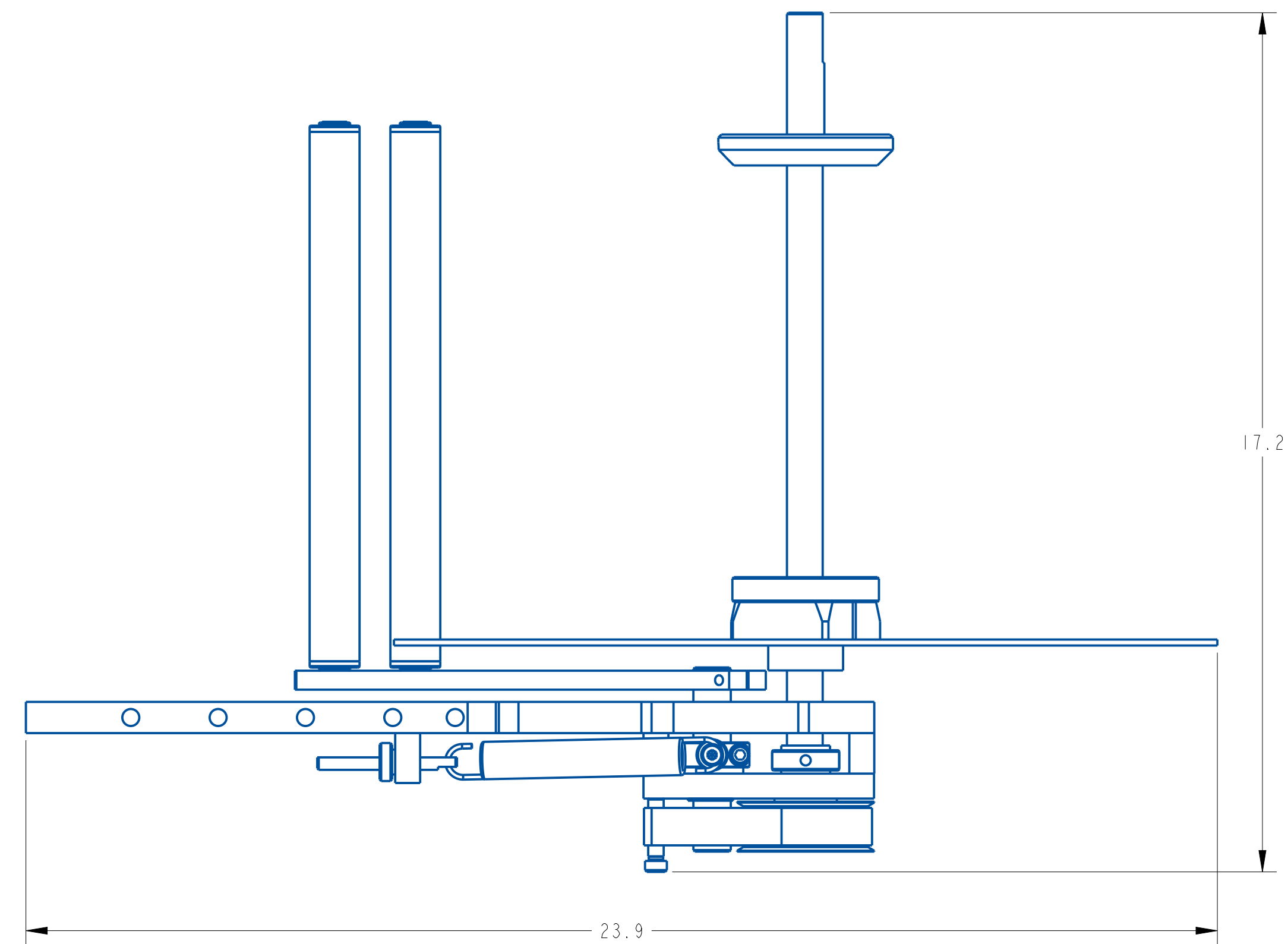
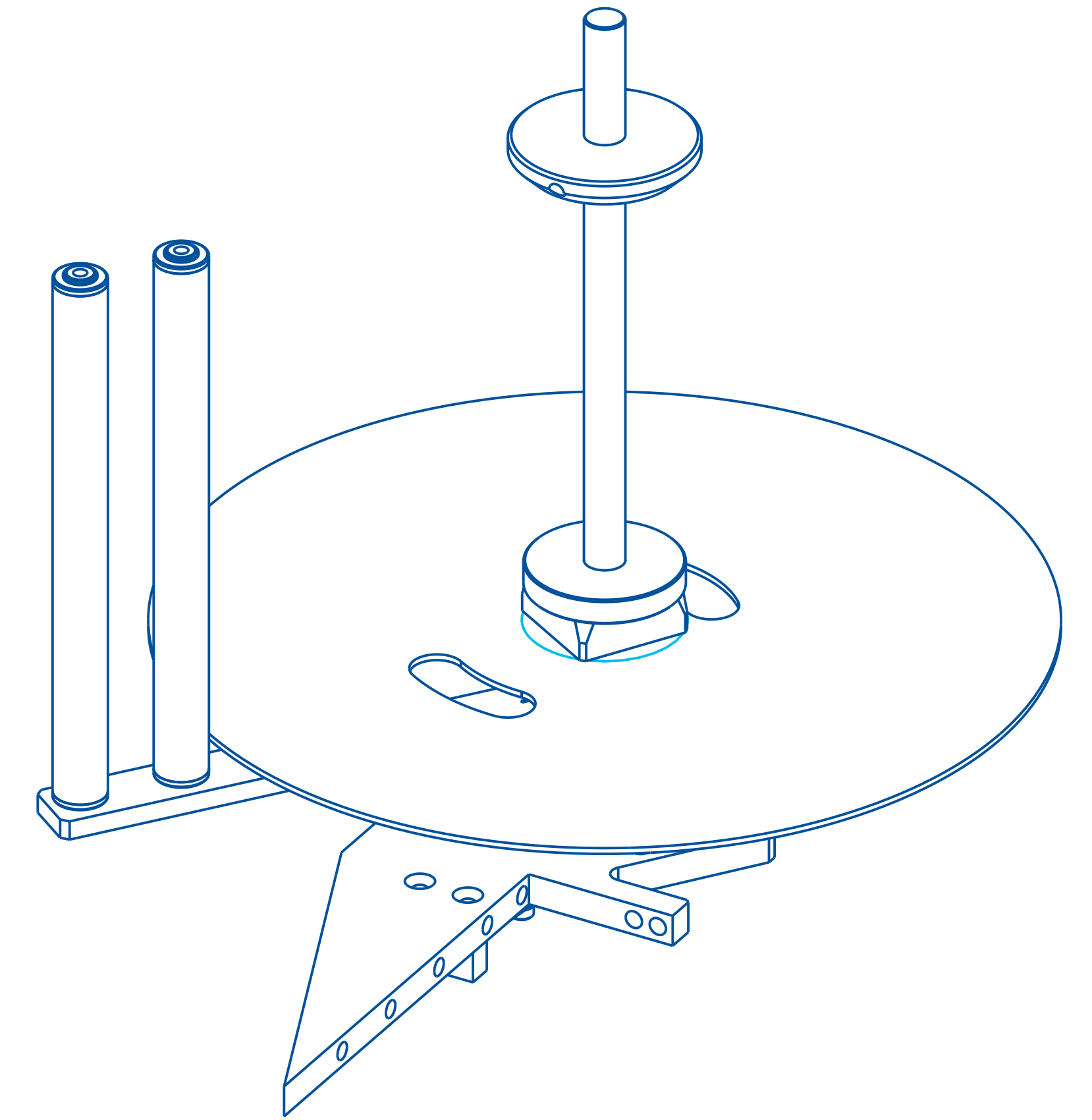
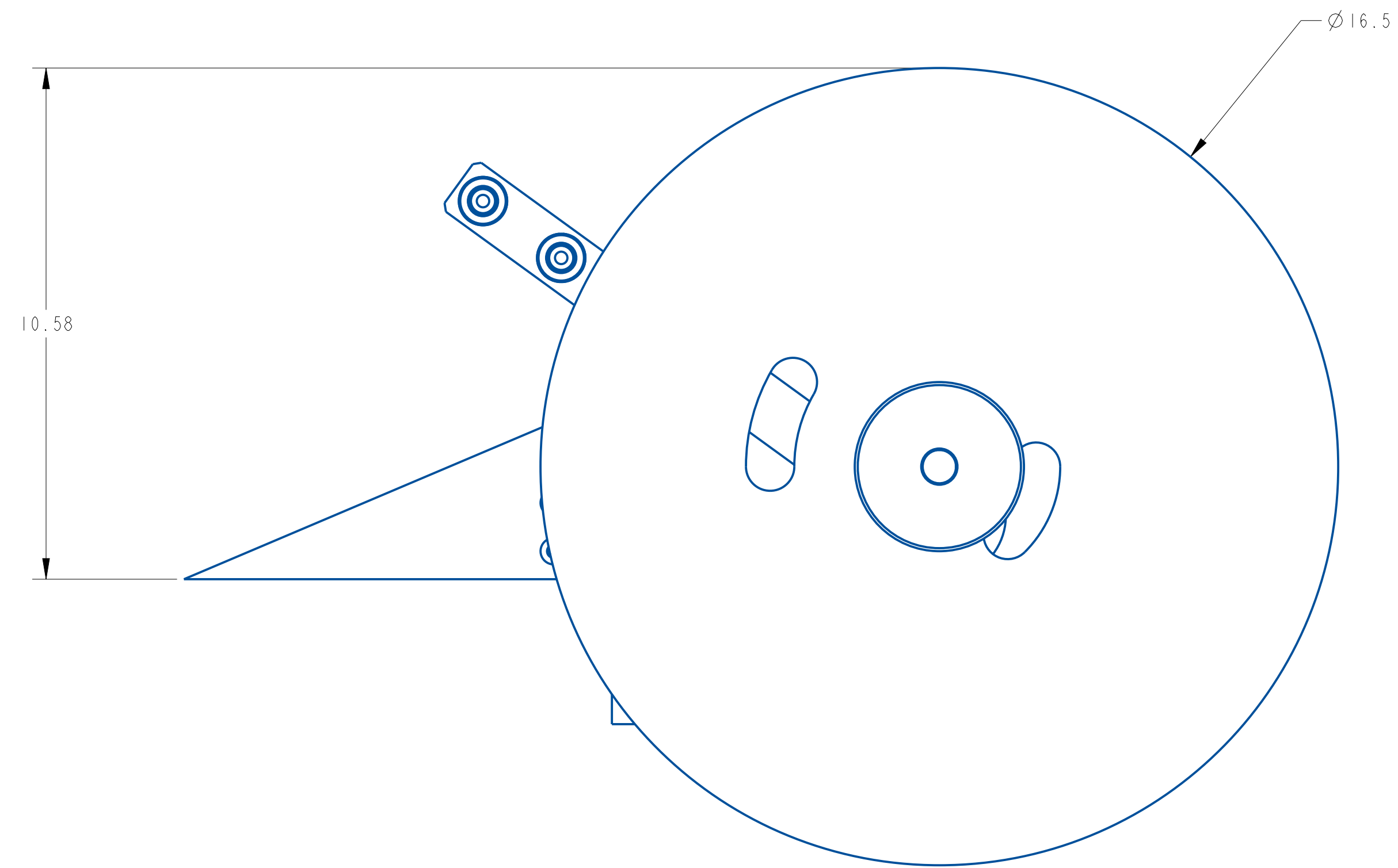

THIS IS A PRO-ENGINEER DOCUMENT AND MAY NOT BE MODIFIED MANUALLY

UNLESS OTHERWISE SPECIFIED DIMENSIONAL TOLERANCE		QUADREL LABELING SYSTEMS 7670 JENTHER DRIVE MENTOR, OHIO 44060 (440) 602-4700		SCALE: 7/16 DATE: Oct-13-25 DRW BY: RDL CHK BY: APPR BY:
x ± .1	xx ± .01	xxx ± .005	ANGLES ± .30°	10" UNWIND ASSEMBLY
SURFACE FINISH 125			MATERIAL	
BREAK ALL EDGES .005/ .015			23100U-010RH	
CORNER RADIUS .010/ .030				
ALL ANGLES ARE 90°				

A	Oct-13-25	NEW DRAWING	RDL
REV	DATE	DESCRIPTION	BY

ASSEMBLY TITLE: Q65 PEEL PLATE ASSEMBLY

DRAWING NO.: C20812-000

GENERAL FUNCTION:

- The peel plate separates the label from the liner and puts the label in a "Flag" position.
- The mounting rods support the slot sensor assembly.
- The guide collars and the idler roller guide the web position over the peel plate
- The pivot pin provides for yoke mounting of the labeling head.

SET UP AND ADJUSTMENTS:

- On machines so equipped, the peel plate may be pivoted at various angles relating to the product by loosening the peel plate mounting bar. (The peel plate of all other models is mounted at a fixed angle and cannot be adjusted)
- To advance label flag on peel plate, move the slot sensor towards the peel plate. To decrease label flag, move slot sensor away from the peel plate.
- Position guide collars on idler roll, one slightly above and the other slightly below the web.

MAINTENANCE:

- Clean all the parts that may acquire labels or glue residue.

TROUBLESHOOTING:

PROBLEM

- Too much label flag at peel
- Too little label flag at peel
- Web moving up and down peel plate

WHAT TO DO

- Move slot sensor away from peel plate edge.
- Move slot sensor towards peel plate edge
- Make sure guide collars are properly positioned on idler roll.



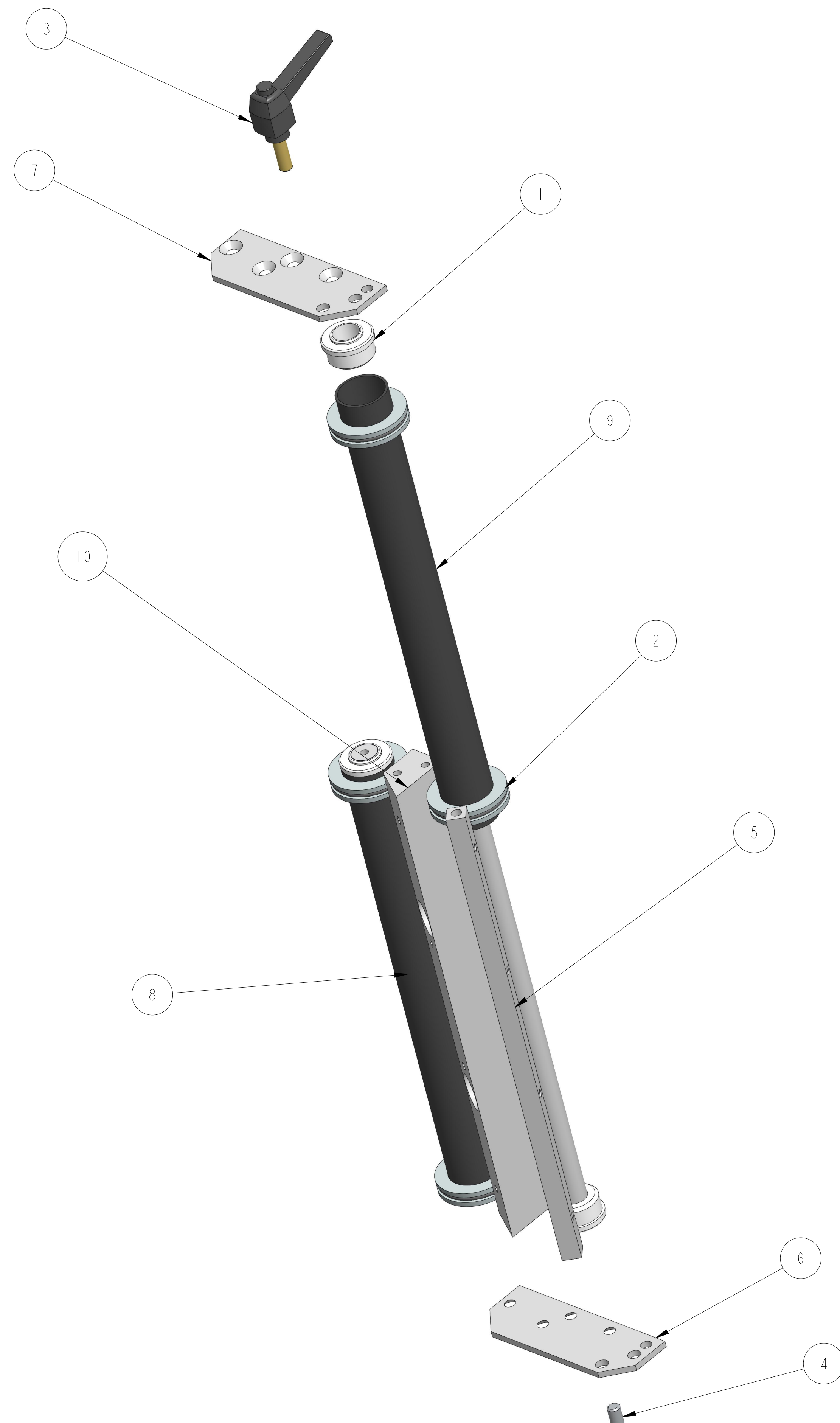

ITEM	QTY	PART NO.	DESCRIPTION	PARENT ITEM
1	4	181063-000	BEARING, ROLL END	20828PP-00R
2	4	361198-000	COLLAR, GUIDE, 1" ID	20828PP-00R
3	1	801857-000	ADJUSTABLE HANDLE	20828PP-00R
4	1	871369-000	DOWEL PIN, 1/4 DIA X 1/2 LONG	20828PP-00R
5	1	A21371-000	PRESSURE SHOE MOUNTING BAR	20828PP-00R
6	1	A21758-000	SIDE PLATE	20828PP-00R
7	1	A21758-001	SIDE PLATE	20828PP-00R
8	2	A23791-001	SHAFT, IDLER ROLLER	20828PP-00R
9	2	B21198-002	10" WEB IDLER ROLLER (PEEL PLATE)	20828PP-00R
10	1	B21274-000	10" PEEL PLATE MOUNTING BAR	20828PP-00R

NOT SHOWN:
A22019-000 PEEL PLATE
A21388-000 PRESSURE SHOE
791852-000 PEEL PLATE TAPE

REV	DATE	DESCRIPTION	BY
B	02-APR-2024	UPDATED DRAWING AND BOM	CRT
A	02-APR-2024	NEW DRAWING	CRT

THIS IS A PRO-ENGINEER DOCUMENT AND MAY NOT BE MODIFIED MANUALLY

UNLESS OTHERWISE SPECIFIED DIMENSIONAL TOLERANCE X ± .1 XX ± .01 XXX ± .005 ANGLES ± 30° SURFACE FINISH 125 BREAK ALL EDGES .005/0.15 CORNER RADIUS .010/0.30	 QUADREL LABELING SYSTEMS 7670 JENTHER DRIVE MENTOR, OHIO 44060 (440) 602-4700	SCALE: 0.750
		DATE: 02-APR-2024
		DRW BY: CRT
		CHK BY: CRT
Q10 RH PEEL PLATE, 10"		APPR BY:
MAT'L 20828PP-000		20828PP-00R

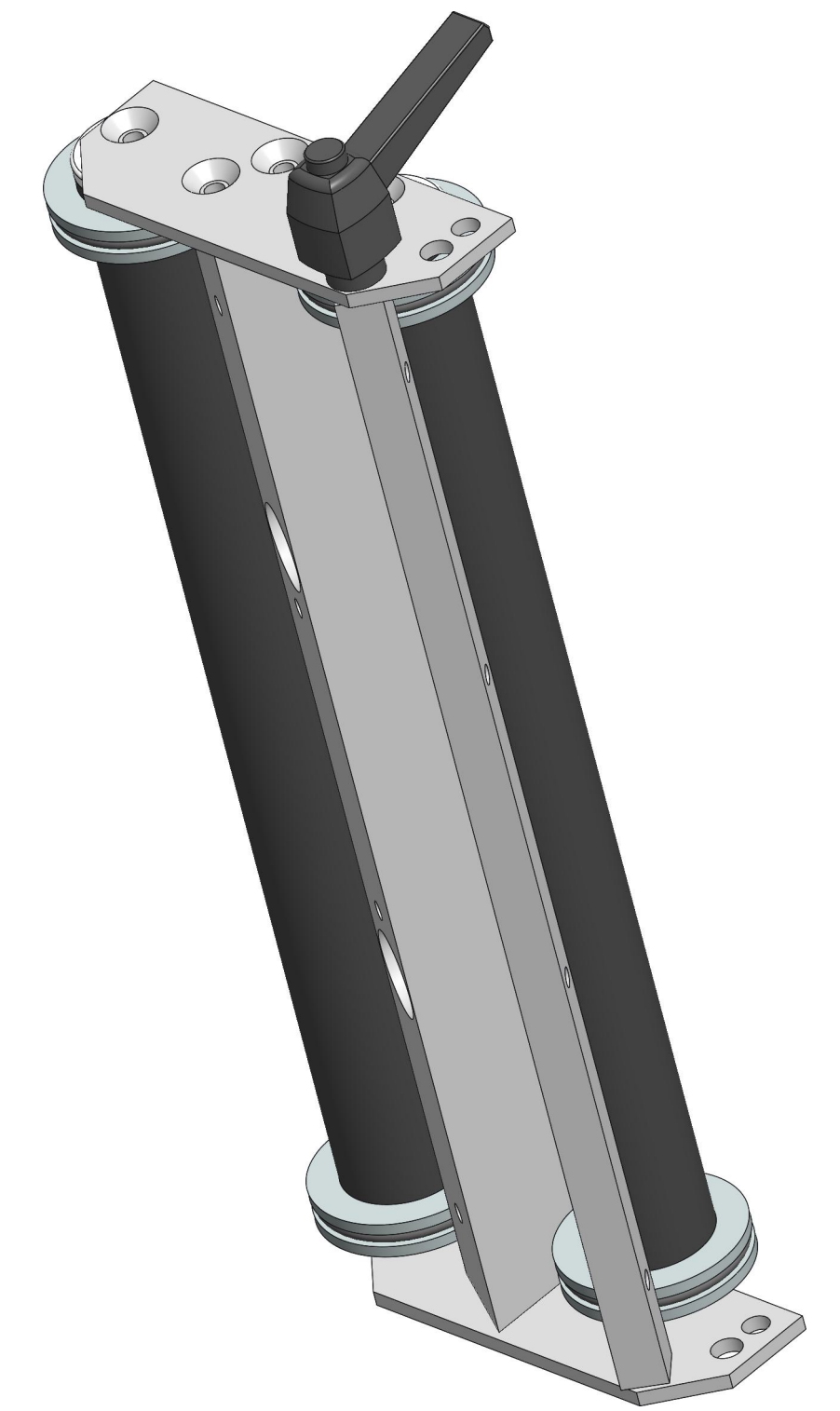
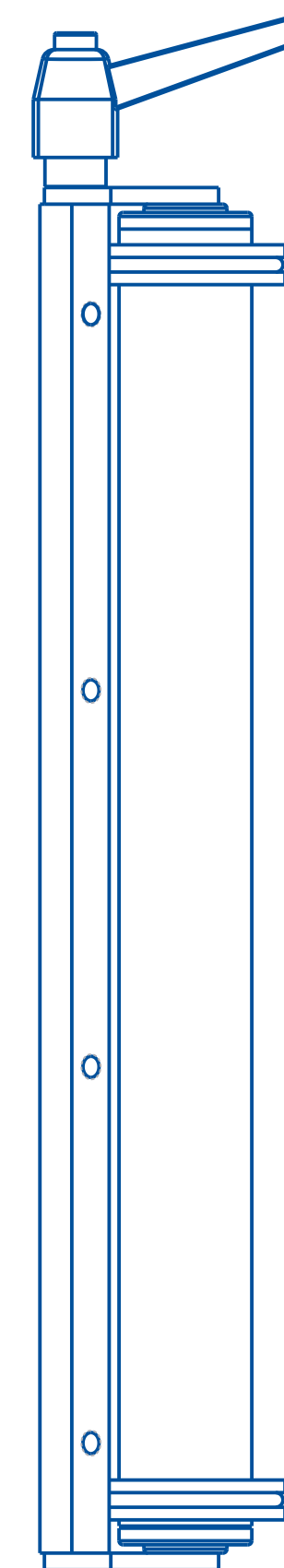
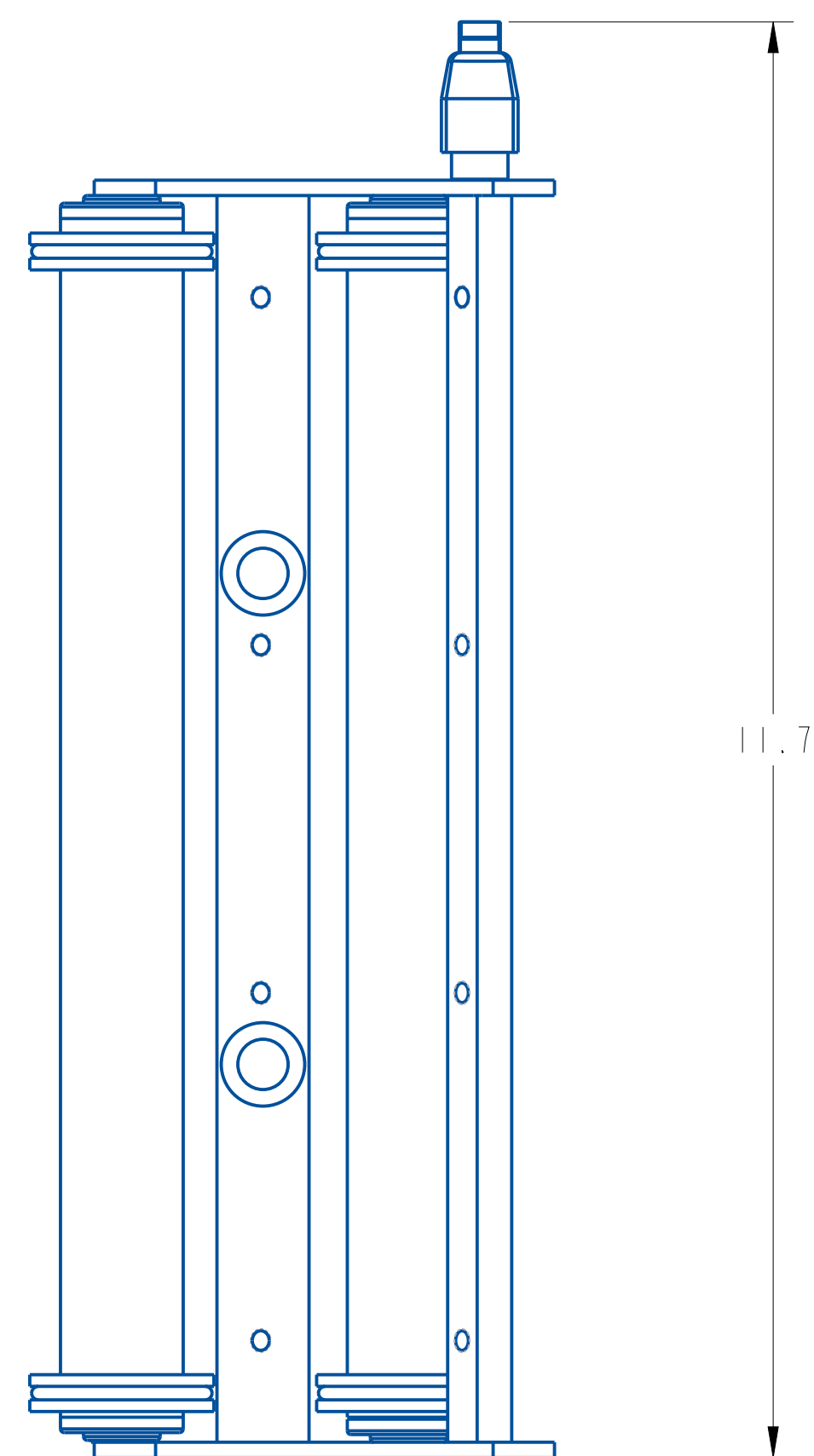
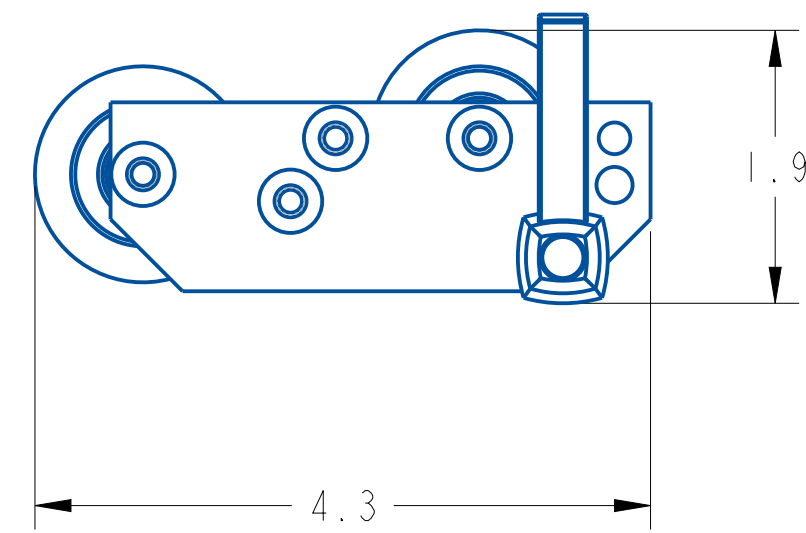

REV	DATE	DESCRIPTION	BY
B	02-APR-2024	UPDATED DRAWING AND BOM	CRT
A	02-APR-2024	NEW DRAWING	CRT

THIS IS A PRO-ENGINEER DOCUMENT AND MAY NOT BE MODIFIED MANUALLY			
UNLESS OTHERWISE SPECIFIED DIMENSIONAL TOLERANCE .X ± .1 .XX ± .01 .XXX ± .005 ANGLES ± 30° SURFACE FINISH 125 BREAK ALL EDGES .005/ .015 CORNER RADIUS .010/ .030	QUADREL LABELING SYSTEMS 7670 JENTHER DRIVE MENTOR, OHIO 44060 (440) 602-4700	SCALE: 0.750	DATE: 02-APR-2024
		DRW BY: CRT	CHK BY:
		APPR BY:	
		Q10 RH PEEL PLATE, 10"	
MAT'L	20828PP-000	20828PP-00R	

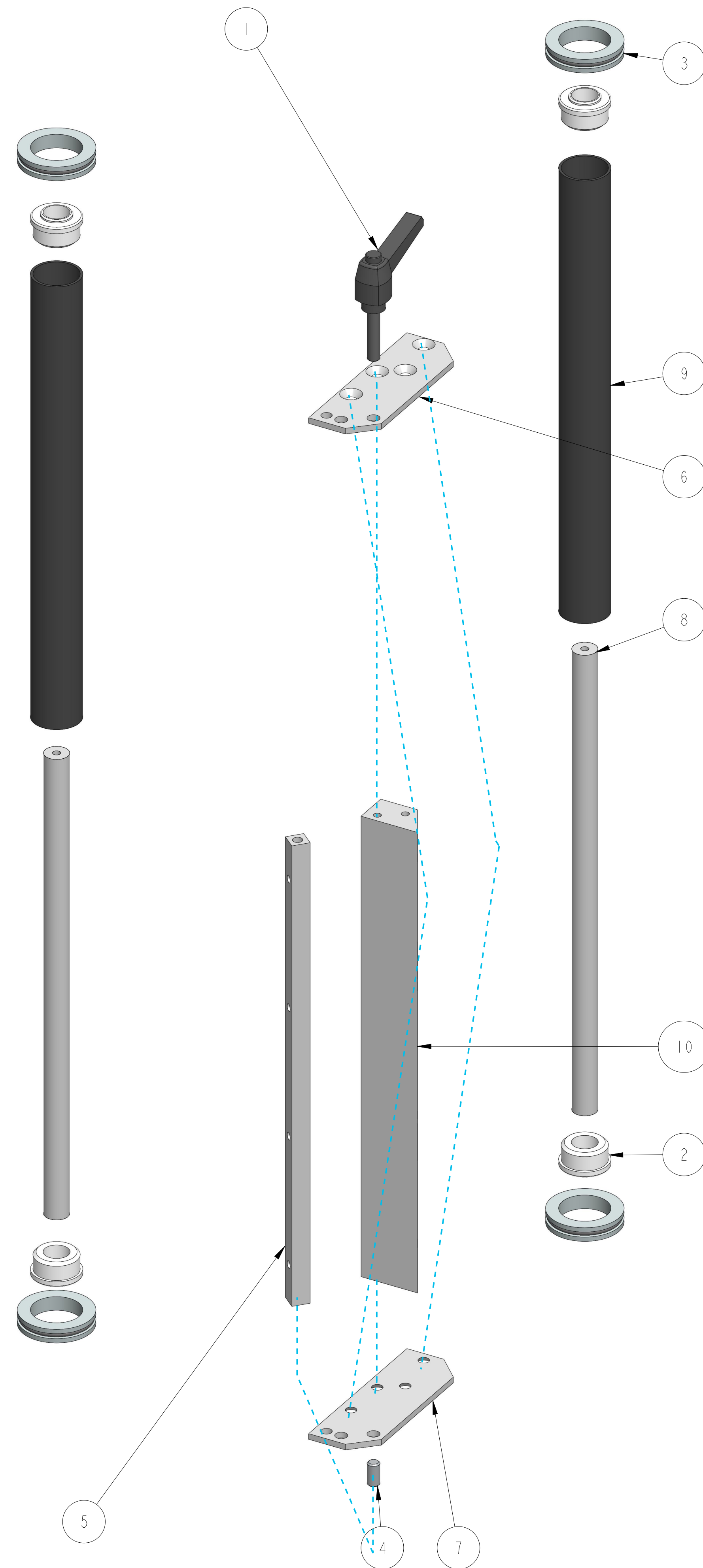

ITEM	QTY	PART NO.	DESCRIPTION	PARENT ITEM
1	1	22811-000	HANDLE ASSEMBLY, LEFT HANDED	20828PP-00L
2	4	181063-000	BEARING, ROLL END	20828PP-00L
3	4	361198-000	COLLAR, GUIDE, 1" ID	20828PP-00L
4	1	871369-000	DOWEL PIN, 1/4 DIA X 1/2 LONG	20828PP-00L
5	1	A21371-001	PRESSURE SHOE MOUNTING BAR	20828PP-00L
6	1	A21758-000	SIDE PLATE	20828PP-00L
7	1	A21758-001	SIDE PLATE	20828PP-00L
8	2	A23791-001	SHAFT, IDLER ROLLER	20828PP-00L
9	2	B21198-002	10" WEB IDLER ROLLER (PEEL PLATE)	20828PP-00L
10	1	B21274-000	10" PEEL PLATE MOUNTING BAR	20828PP-00L

NOT SHOWN:
A22019-000 PEEL PLATE
A21388-000 PRESSURE SHOE
791852-000 PEEL PLATE TAPE

REV	DATE	DESCRIPTION	BY
A	02-APR-2024	NEW DRAWING	CRT

THIS IS A PRO-ENGINEER DOCUMENT AND MAY NOT BE MODIFIED MANUALLY

UNLESS OTHERWISE SPECIFIED DIMENSIONAL TOLERANCE X ± .1 XX ± .01 XXX ± .005 ANGLES ± .30°	QUADREL LABELING SYSTEMS 7670 JENTHER DRIVE MENTOR, OHIO 44060 (440) 602-4700	SCALE: 0.690 DATE: 02-APR-2024 DRW BY: CRT CHK BY: 04/19/2024-SEM APPR BY:
Q10 RH PEEL PLATE, 10"		
MAT'L	20828PP-000	20828PP-00L

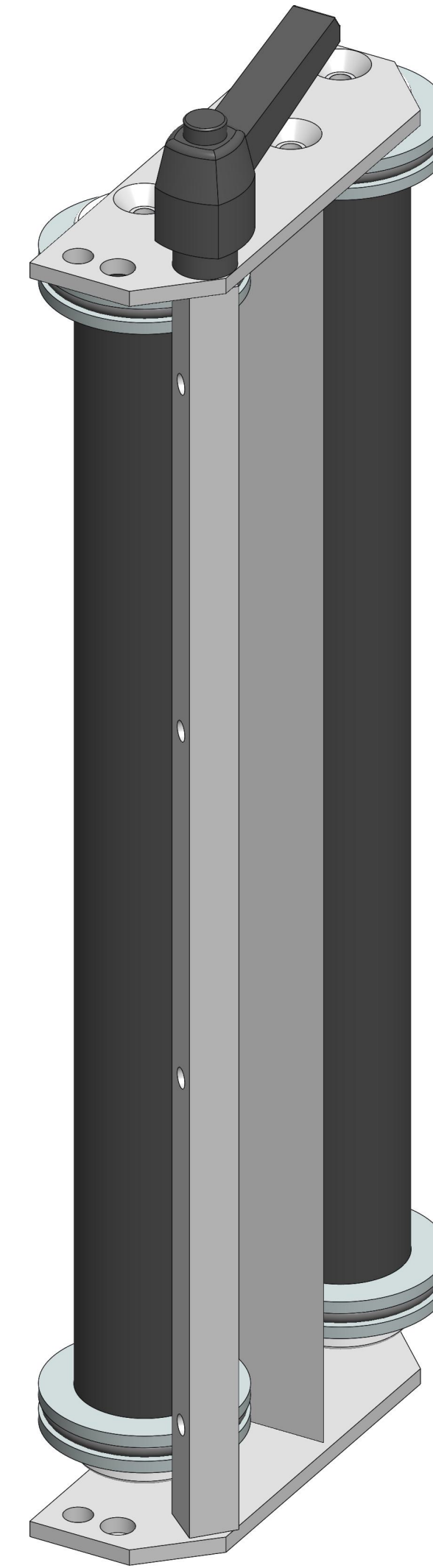
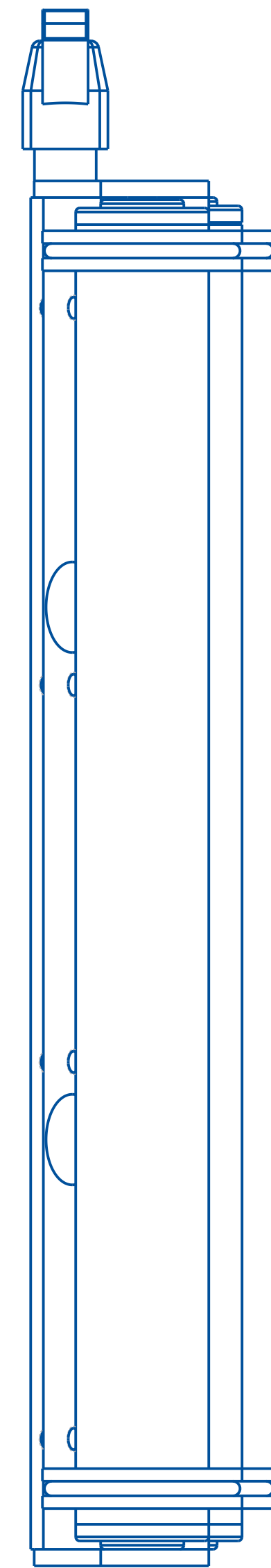
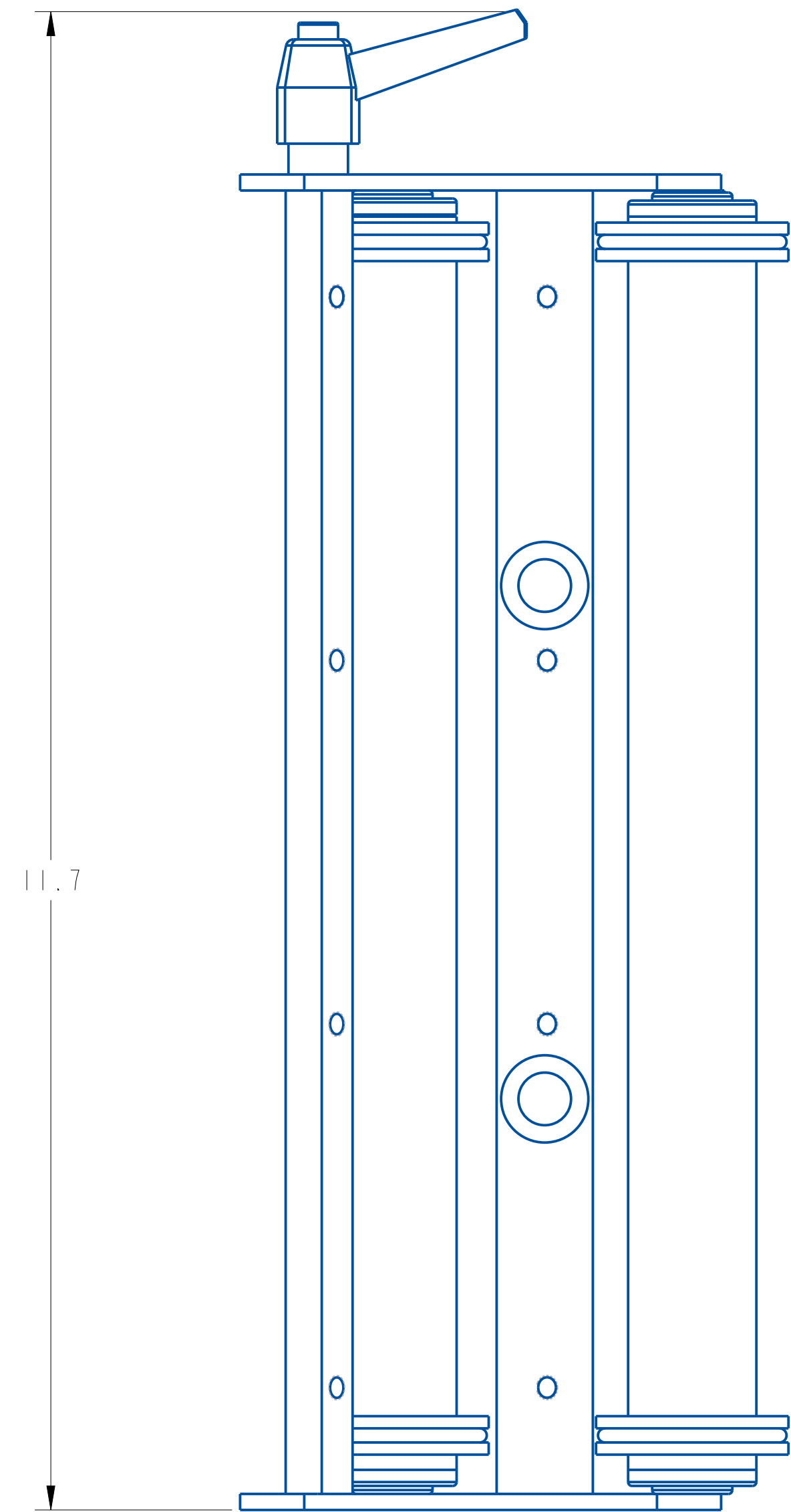
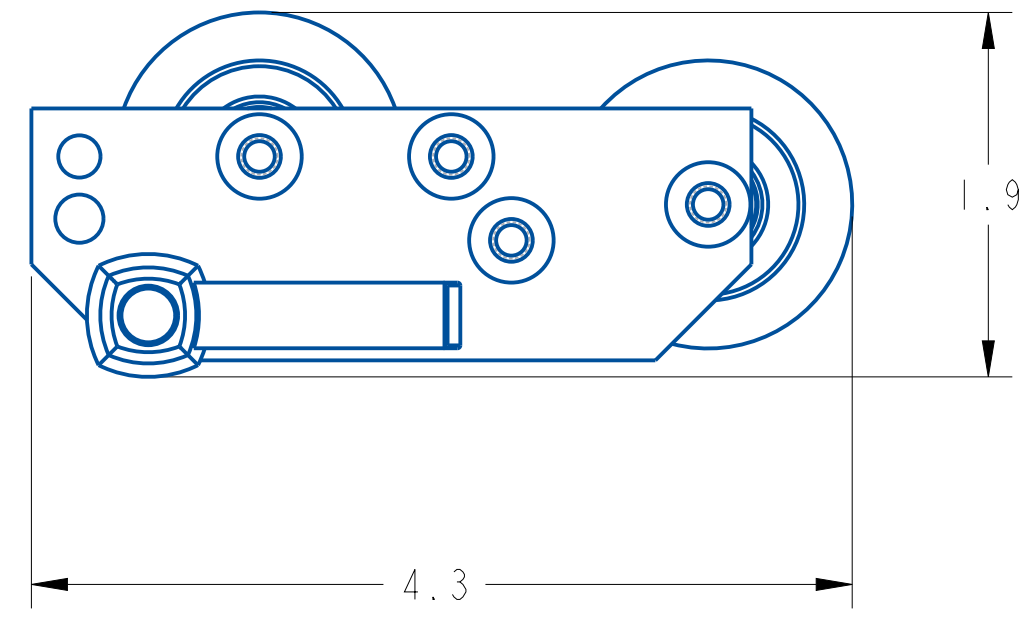

REV	DATE	DESCRIPTION	BY
A	02-APR-2024	NEW DRAWING	CRT

THIS IS A PRO-ENGINEER DOCUMENT AND MAY NOT BE MODIFIED MANUALLY

UNLESS OTHERWISE SPECIFIED DIMENSIONAL TOLERANCE	<p> $x \pm .1$ $xx \pm .01$ $xxx \pm .005$ ANGLES $\pm .30^\circ$ </p>	<p> SCALE: 1.000 DATE: 02-APR-2024 DRW BY: CRT CHK BY: 04/19/2024-SEM APPR BY: </p>
<p> QUADREL LABELING SYSTEMS 7670 JENTHER DRIVE MENTOR, OHIO 44060 (440) 602-4700 </p>		
<p>Q10 RH PEEL PLATE, 10"</p>		
MAT'L	20828PP-00L	20828PP-00L

ITEM	QTY	PART NO.	DESCRIPTION	PARENT ITEM
1	1	801899-000	HANDLE	22811-000
2	1	841812-000	STUD	22811-000

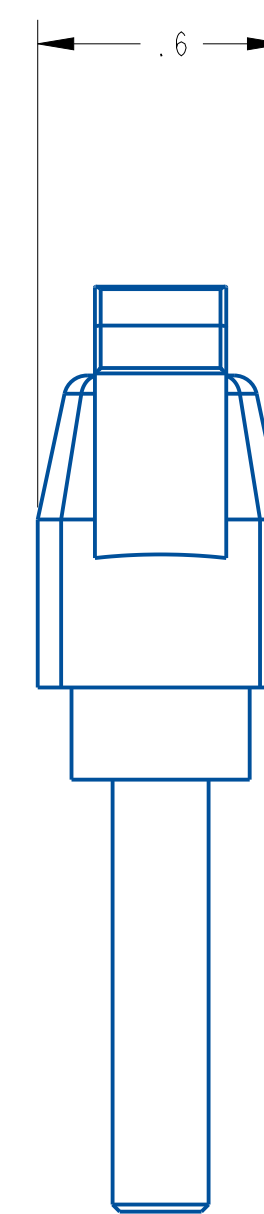
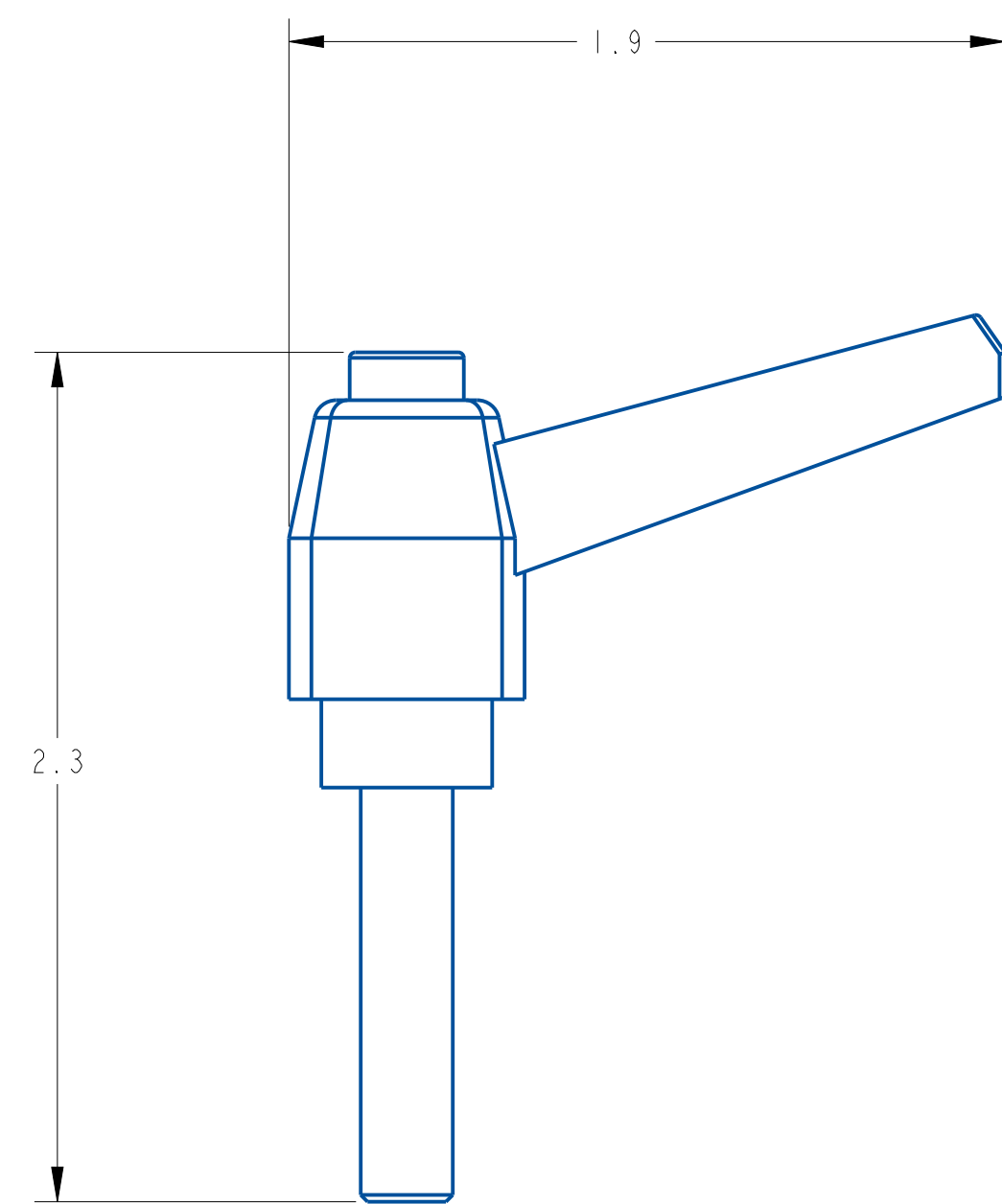
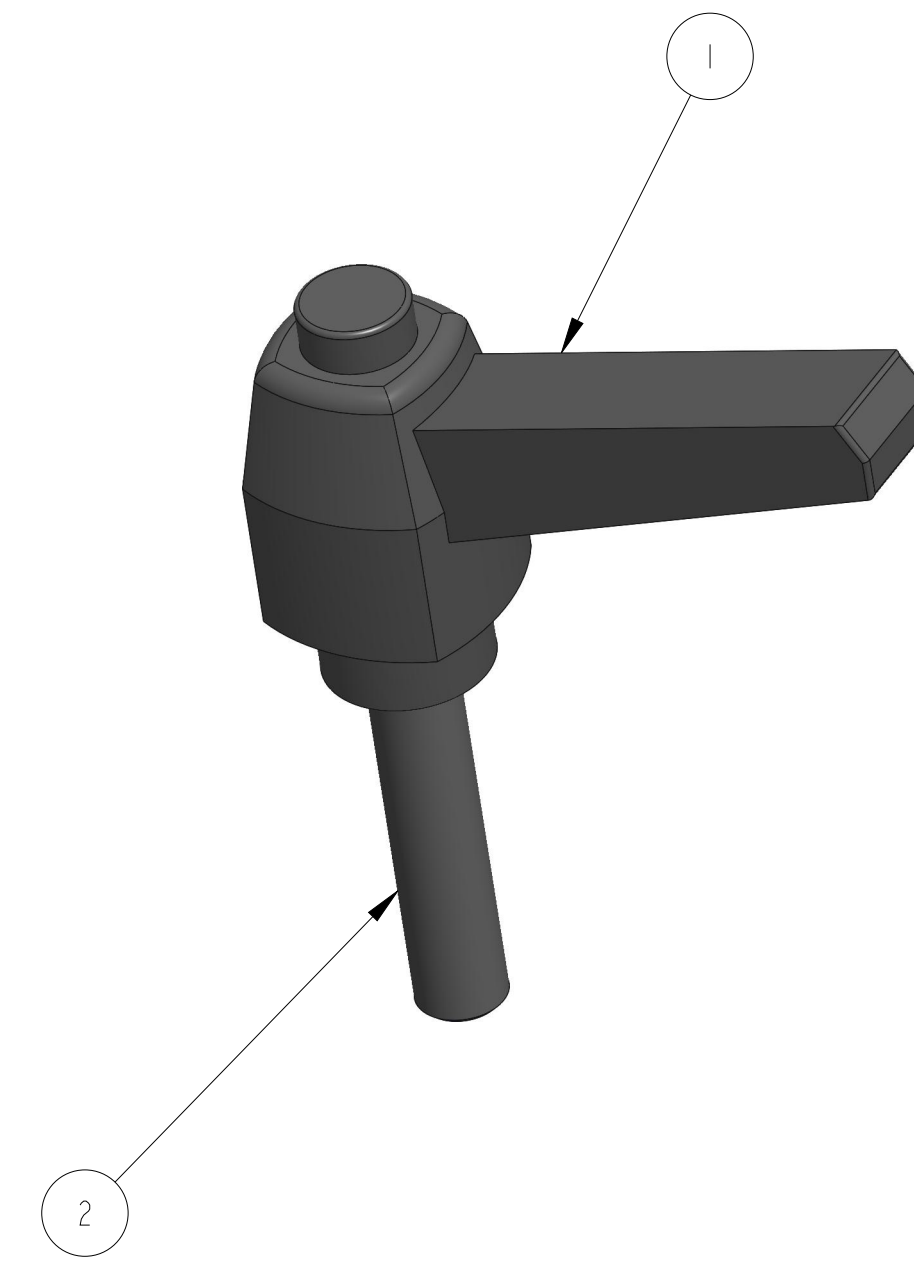
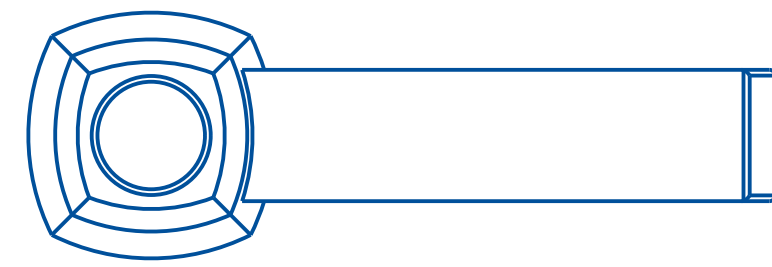

REV	DATE	DESCRIPTION	BY
A	Feb-05-24	NEW DRAWING	CRT

THIS IS A PRO-ENGINEER DOCUMENT AND MAY NOT BE MODIFIED MANUALLY

UNLESS OTHERWISE SPECIFIED DIMENSIONAL TOLERANCE .X ± .1 .XX ± .01 .XXX ± .005 ANGLES ± 30°	QUADREL LABELING SYSTEMS 7670 JENTHER DRIVE MENTOR, OHIO 44060 (440) 602-4700	SCALE: 2/1 DATE: Feb-05-24 DRW BY: CRT CHK BY: APPR BY:
--	---	---

HANDLE ASSEMBLY, LEFT HANDED THREAD

MAT'L	22811-000
-------	-----------

ASSEMBLY TITLE: FIXED BRUSH IMPRESSER

DRAWING NO.: D21651-000

GENERAL FUNCTION:

- The fixed roller impresser is an option used in applications where a secondary wipe down or label wipe is necessary.

SET UP AND ADJUSTMENTS:

- When installed, the brush assembly will be mounted by an adjustable clamp. The mounting assembly is fastener to the option rail located on the peel plate side wall.
- Four axis of adjustment is available by loosening the set screw locking the roller arm in place.
- Locate the brush as necessary and re-tighten the clamping screws.
- Run a product through the brush area and insure the brush layed on the product but do not impede product travel. The brush can be adjusted too close to the product which will prevent the product from smoothly traversing through the brush area.

MAINTENANCE:

- Keep the brush free of label flash, glue and debris. This will prevent jamming and web tears.

NOTE: Exercise caution when removing bad labels from brush. Careless removal can result in brisals being pull out which may leave the labeler inoperable until the brush is replaced!

TROUBLESHOOTING:

PROBLEM

- Product jams at brush area
- Bubbles in label
- Label edge curling
- Wipedown inadequate

WHAT TO DO

- Increase brush spacing.
- Decrease labeling speed
- Decrease product delay
- Decrease brush spacing.

ITEM	QTY	PART NO.	DESCRIPTION	PARENT ITEM
1	1	A21264-018	CROSS ARM	10228-005_R
2	1	A21693-300	IMPRESSOR MOUNTING BLOCK	10228-005_R
3	1	A21758-300	PEEL PLATE SIDE PLATE .375"THK	10228-005_R
4	1	A23463-100	BRUSH HOLDER	10228-005_R

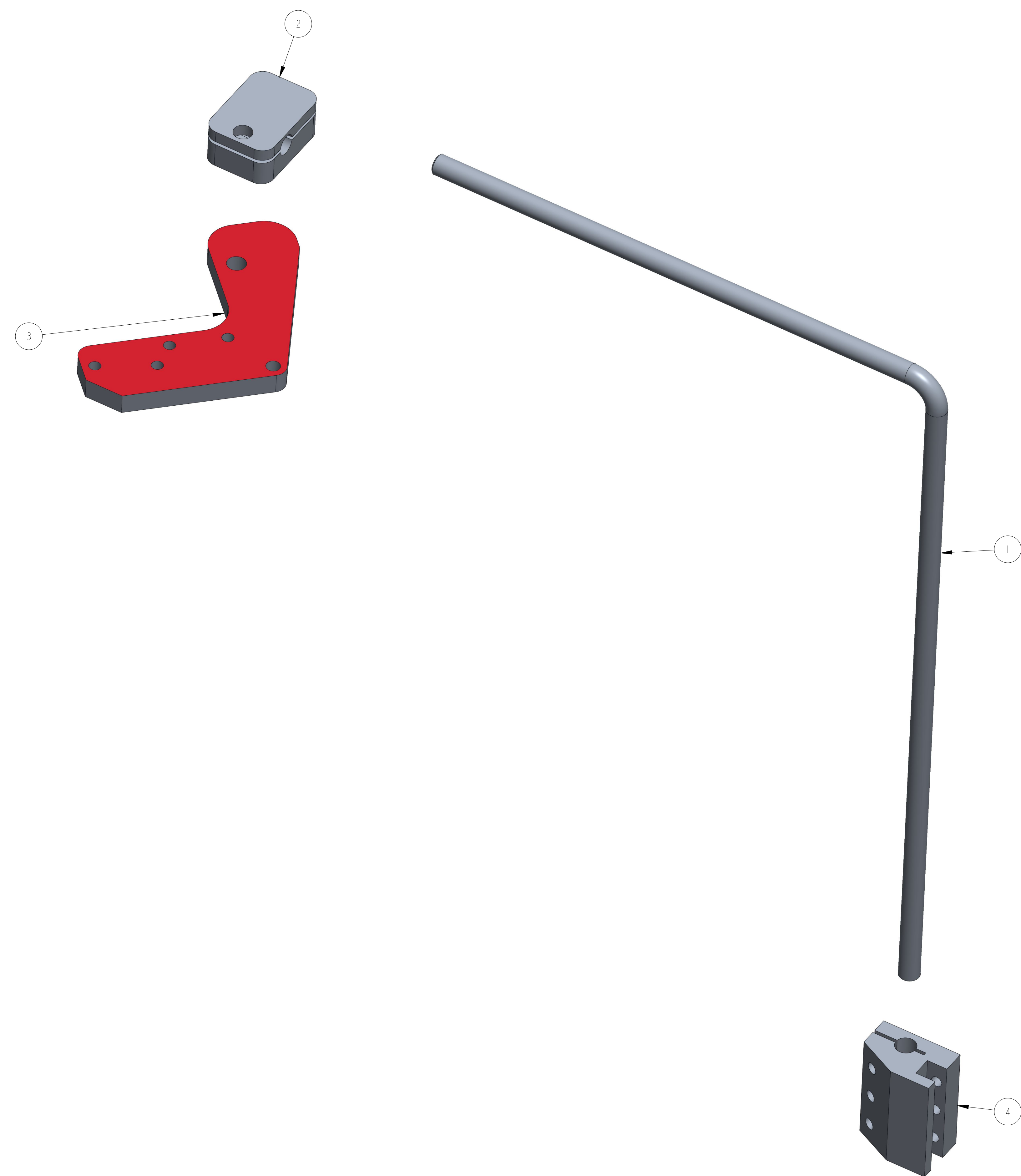

REV	DATE	DESCRIPTION	BY
A	Mar-02-20	NEW DRAWING	TJS

THIS IS A PRO-ENGINEER DOCUMENT AND MAY NOT BE MODIFIED MANUALLY

UNLESS OTHERWISE SPECIFIED DIMENSIONAL TOLERANCE .X ± .1 .XX ± .01 .XXX ± .005 ANGLES ± 30°	QUADREL LABELING SYSTEMS 7670 JENTHER DRIVE MENTOR, OHIO 44060 (440) 602-4700	SCALE: 1/1 DATE: Mar-02-20 DRW BY: TJS CHK BY: 03/06/2024-SEM APPR BY:
SURFACE FINISH 125 BREAK ALL EDGES .005/0.15 CORNER RADIUS .010/0.30		HEAVY DUTY IMPRESSOR MAT'L 10228-005

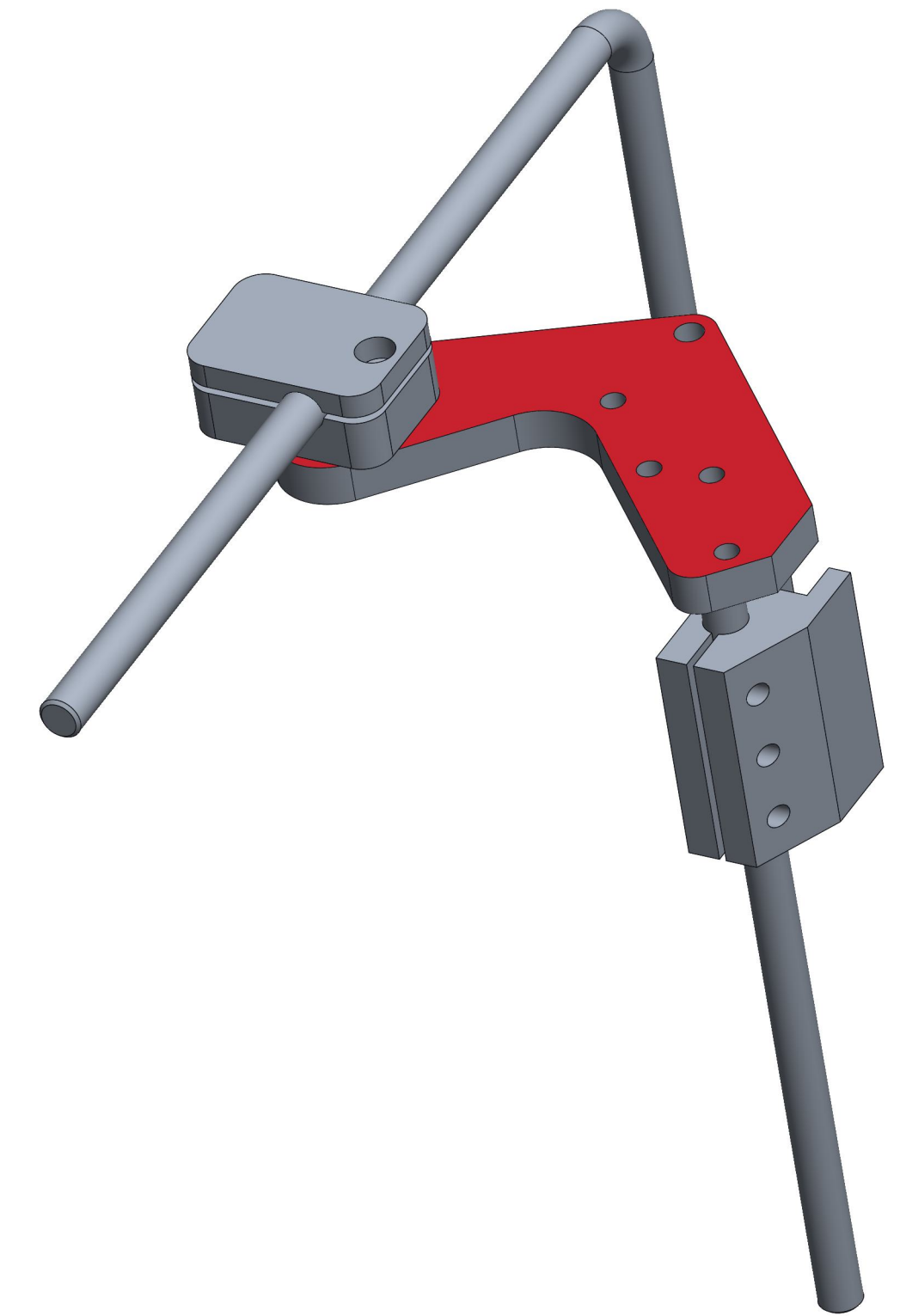
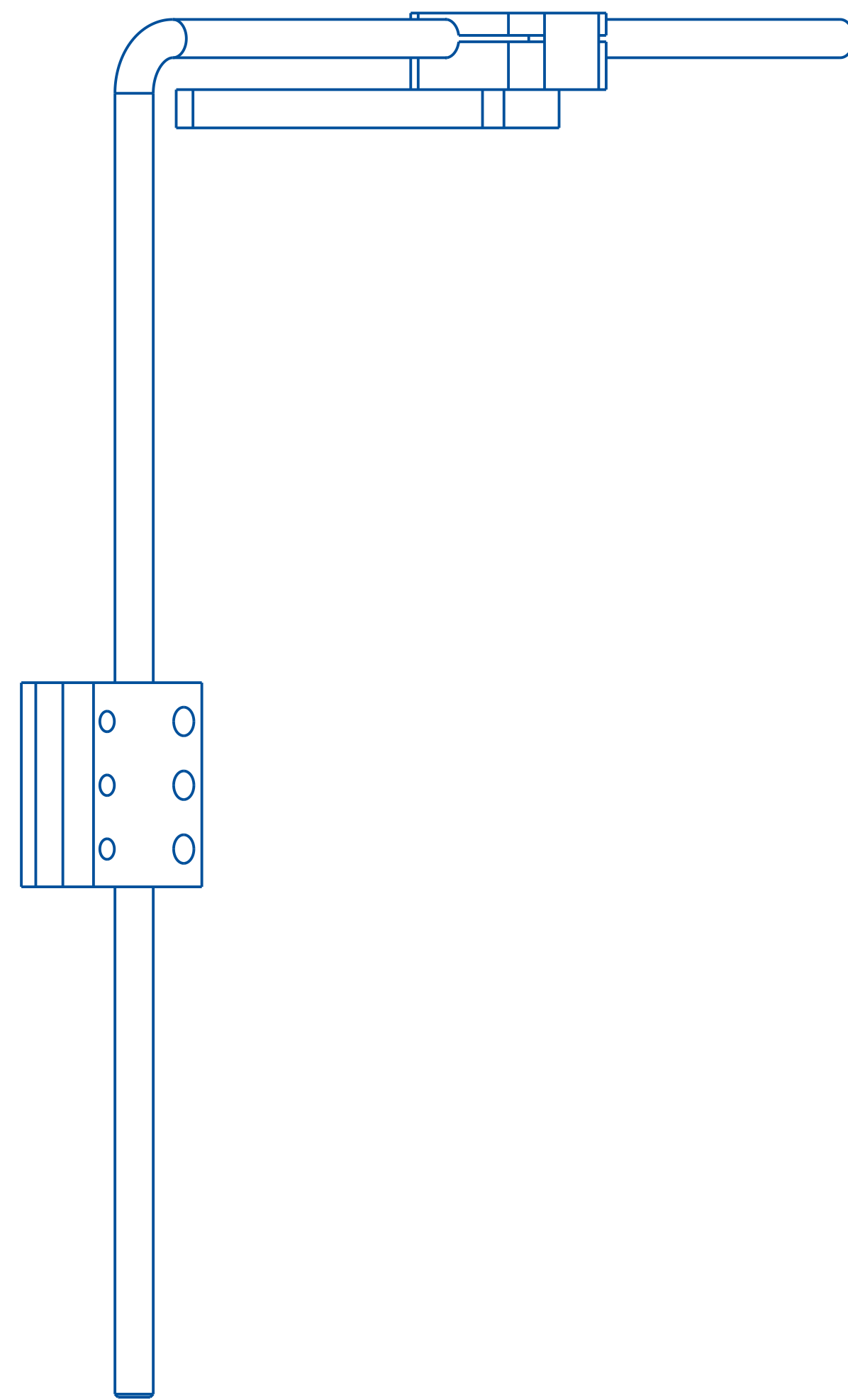
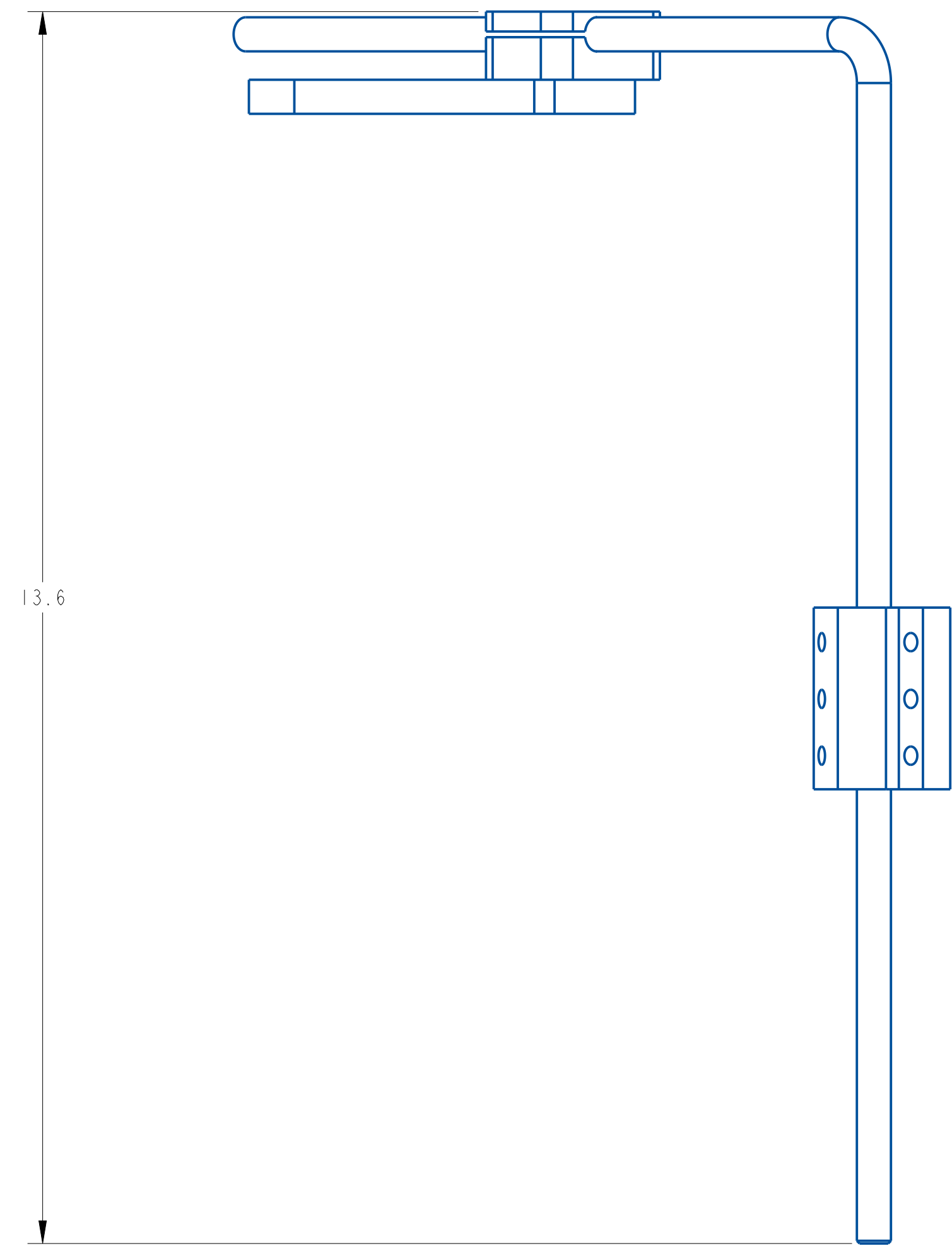
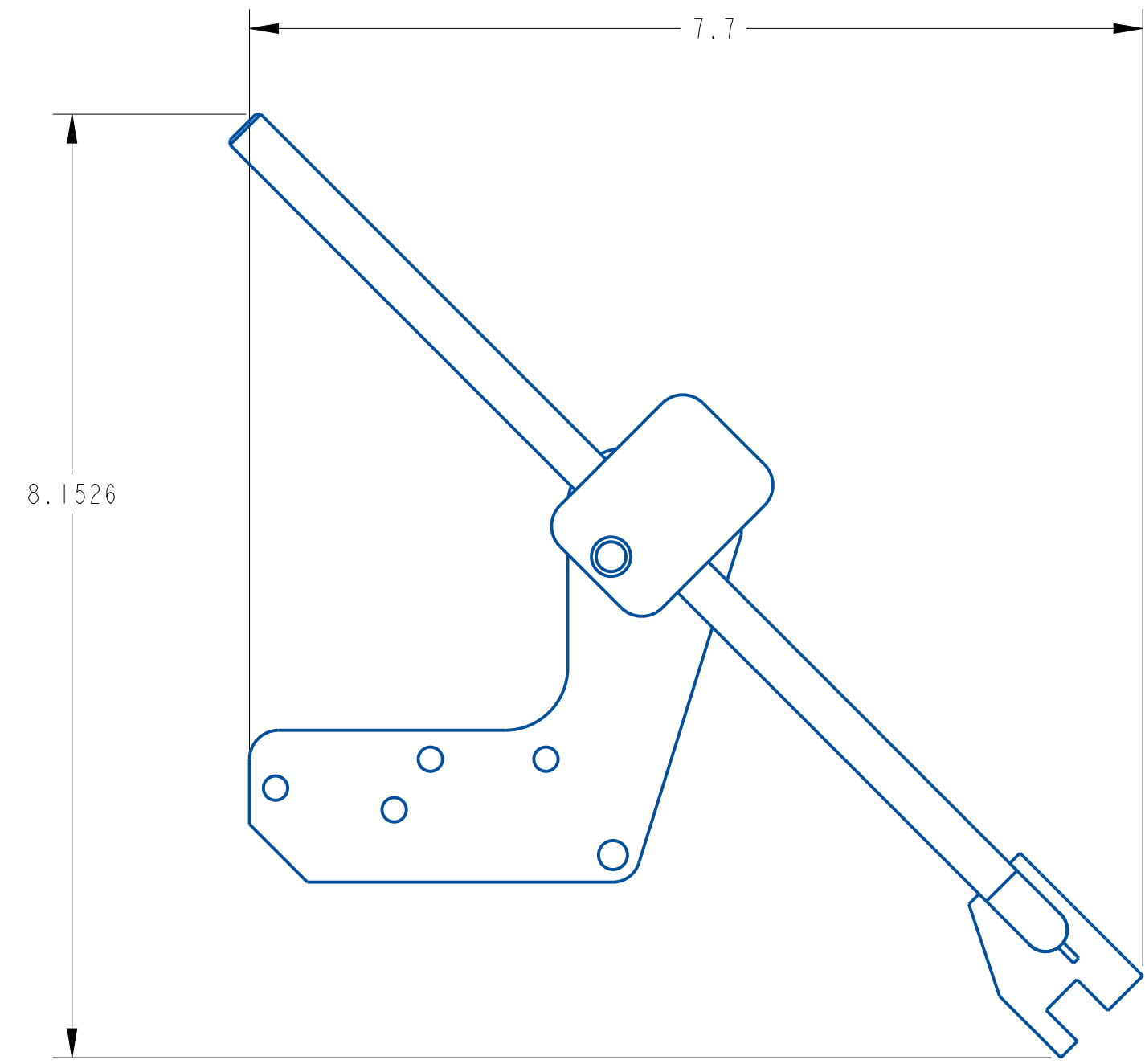

REV	DATE	DESCRIPTION	BY
A	Mar-02-20	NEW DRAWING	TJS

THIS IS A PRO-ENGINEER DOCUMENT AND MAY NOT BE MODIFIED MANUALLY

UNLESS OTHERWISE SPECIFIED
DIMENSIONAL TOLERANCE
x ± .1
xx ± .01
xxx ± .005
ANGLES ± .30°

SURFACE FINISH 125
BREAK ALL EDGES .005/ .015
CORNER RADIUS .010/ .030
ALL ANGLES ARE 90°

QUADREL LABELING SYSTEMS
7670 JENTHER DRIVE
MENTOR, OHIO 44060
(440) 602-4700

SCALE: 3/4
DATE: Mar-02-20
DRW BY: TJS
CHK BY: 03/06/2024-SEM
APPR BY:

HEAVY DUTY IMPRESSOR

MAT'L 10228-005

ASSEMBLY TITLE: Q65 DRIVE AND PINCH ROLL ASSEMBLY

GENERAL FUNCTION:

- The drive roll pulls the liner through the entire labeling head. As the liner is pulled over the peel edge, the label dispenses
- The drive roll pulls the liner through the entire labeling head. As the liner is pulled over the peel edge, the label dispenses.
- The spring-loaded pinch roll squeezes the liner against the drive roll to provide positive drive
- The primary roll is the pull or drive roll as shown. The knurl roll provides a constant pressure against the pull roll.

SET UP AND ADJUSTMENTS:

- When threading the labeling head, use the pinch roll lever to release the pinch roll from the drive roll.
- Use the spring plunger adjustment screws to adjust the contact pressure between the knurl and pull rollers.
- The pressure should be adjusted as tight as necessary to prevent a loose liner, while still allowing full rotation of the pressure release arm.

MAINTENANCE:

- Clean all parts that may have acquired label or glue residue

TROUBLESHOOTING:

<u>PROBLEM</u>	<u>WHAT TO DO</u>
- Meter pulley rubbing against side plate	- Center pulley on motor shaft and tighten two (2) set scr in pulley.
- Web slips	- Drive roller not closed. Turn drive roll arm to closed position.
- Drive roll not rotating when stepping motor rotates	- Replace timing belt from motor to drive roll
- Pinch roll not providing enough pressure against drive roll	- Replace pinch roll spring
	- Increase tension on drive roll by adjusting spring loaded locking pins.
- Drive roll unevenly worn causing tracking problem	- Replace drive roll



ITEM	QTY	PART NO.	DESCRIPTION	PARENT ITEM
1	2	00301-17	SPRING, .275 x .052 x .94	23100DR-010RH
2	2	111072-000	BEARING, BALL	23100DR-010RH
3	3	151004-000	BEARING, THRUST WASHER	23100DR-010RH
4	1	362161-000	COLLAR, SETSCREW, 1/2 IN. ID	23100DR-010RH
5	1	791789-000	NAMEPLATE	23100DR-010RH
6	1	21701DY-000_LH	3 PIECE ROLL ASSEMBLY	23100DR-010RH
7	2	A20567-000	WHITE NYLON SLUG	23100DR-010RH
8	1	A20929-000	PINCH POINT GUARD ROD 12" WEB	23100DR-010RH
9	2	A23125-000	SPACER	23100DR-010RH
10	1	A23751-000	SPACER	23100DR-010RH
11	1	A25249-000	INDEX DOT	23100DR-010RH
12	1	A25250-000	IND KNOB	23100DR-010RH
13	1	B20342-000	PULL ROLL, 10"	23100DR-010RH
14	1	B20344-000	KNURLED ROLL	23100DR-010RH
15	1	B20346-000	KNURLED ROLL SHAFT, 12"	23100DR-010RH
16	1	SYE121		23100DR-010RH

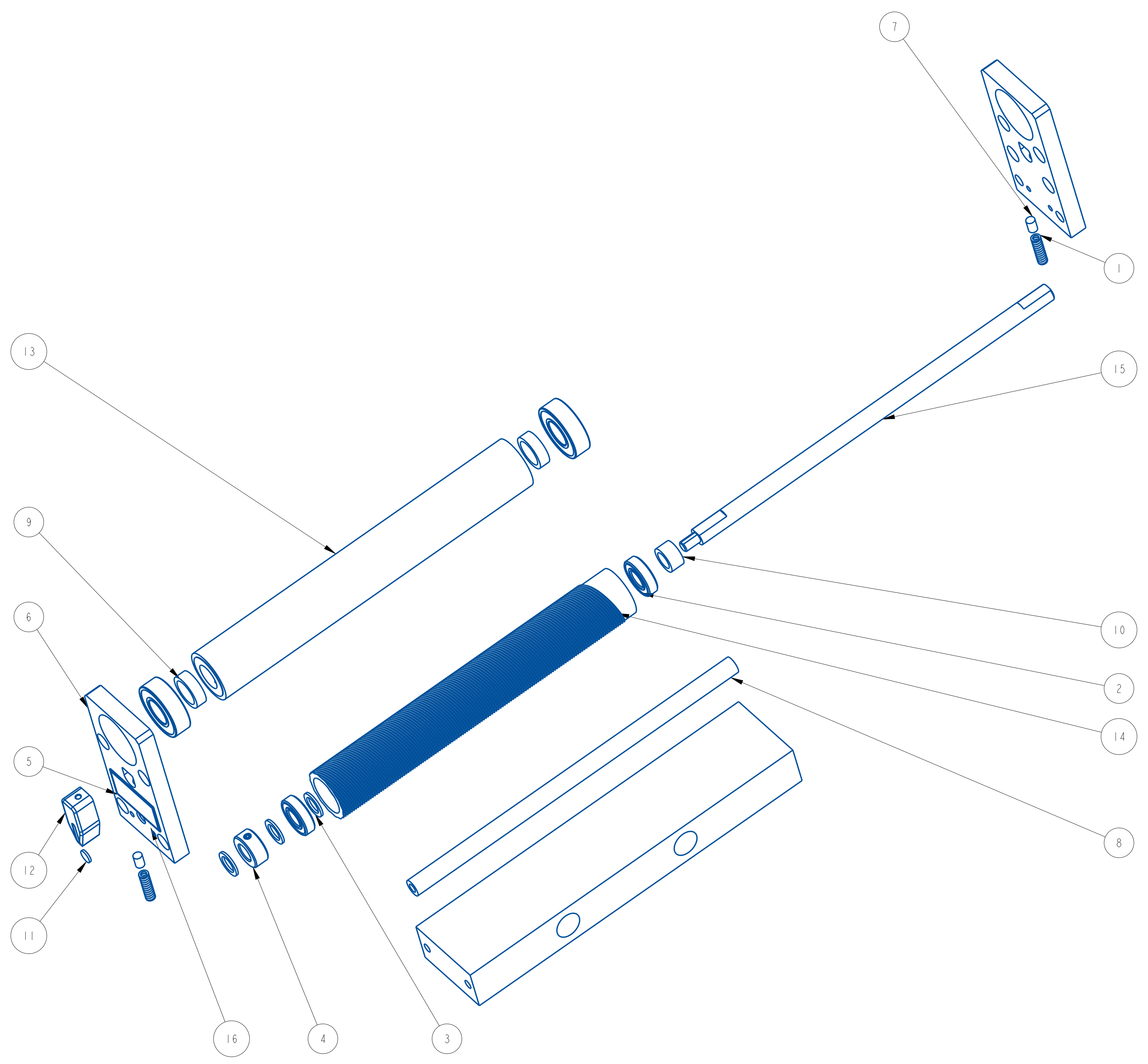

REV	DATE	DESCRIPTION	BY
A	Oct-13-25	NEW DRAWING	RDL

THIS IS A PRO-ENGINEER DOCUMENT AND MAY NOT BE MODIFIED MANUALLY

QUADREL LABELING SYSTEMS
 7670 JENTHER DRIVE
 MENTOR, OHIO 44060
 (440) 602-4700

SCALE: 9/16
 DATE: Oct-13-25
 DRW BY: RDL
 CHK BY:
 APPR BY:

10" DRIVE ROLL ASSEMBLY

MAT'L: 23100DR-010RH

UNLESS OTHERWISE SPECIFIED
 DIMENSIONAL TOLERANCE
 .X ± .01
 .XX ± .005
 .XXX ± .005
 ANGLES ± 30°
 SURFACE FINISH 125
 BREAK ALL EDGES .005/0.15
 CORNER RADIUS .010/0.30
 ALL ANGLES ARE 90°

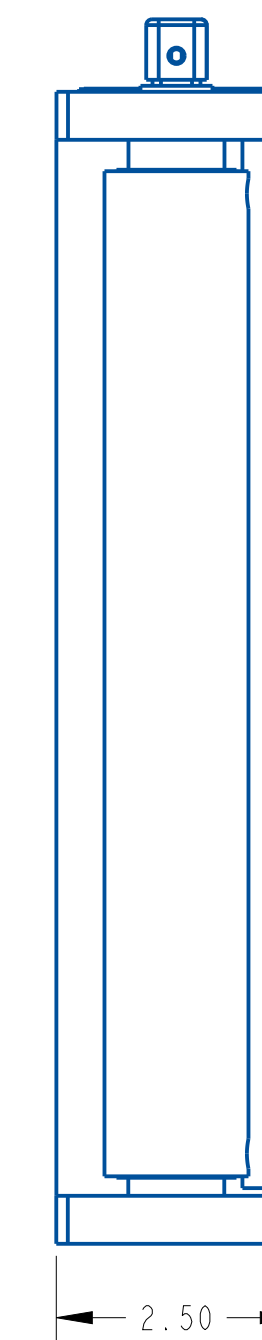
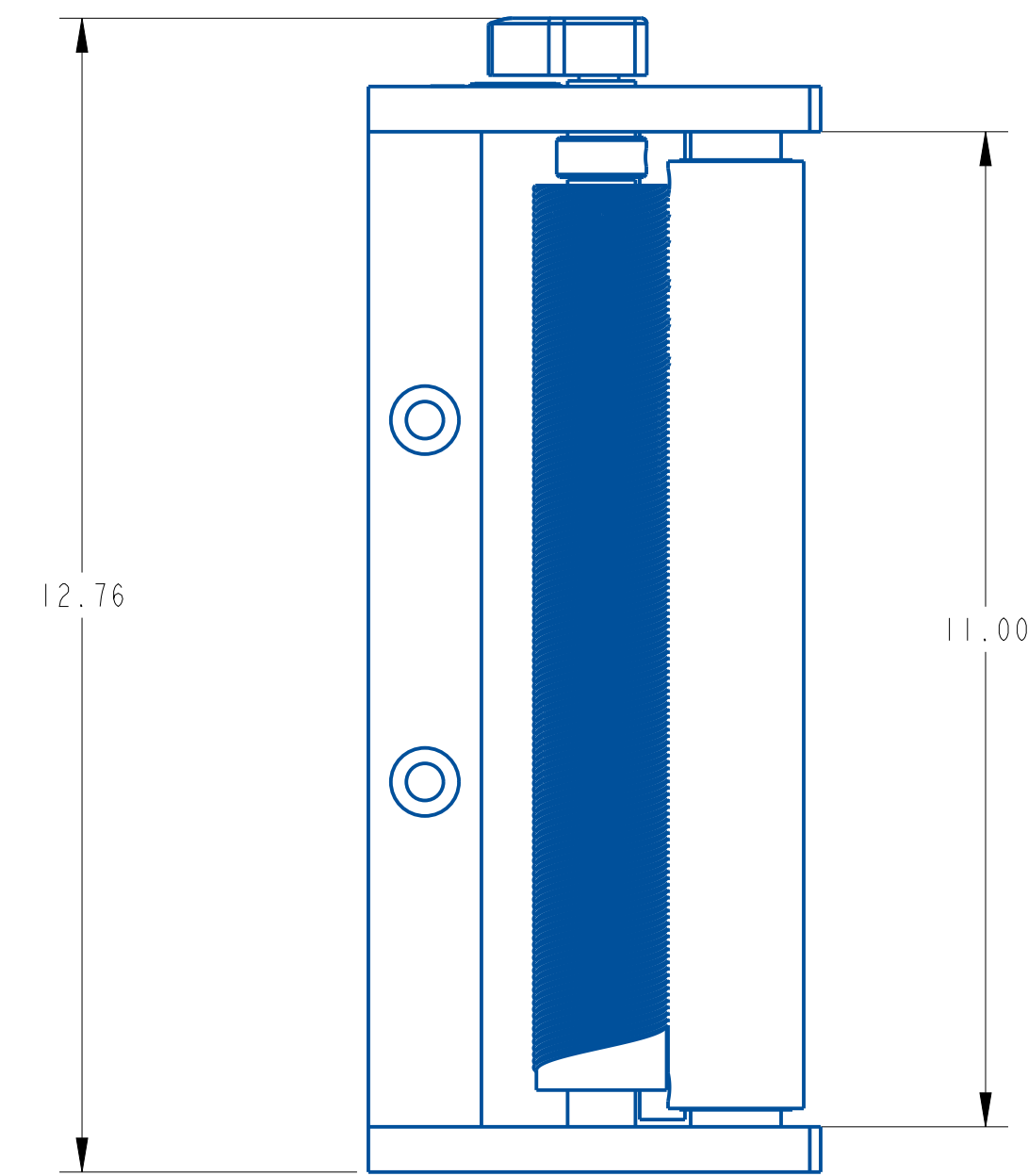
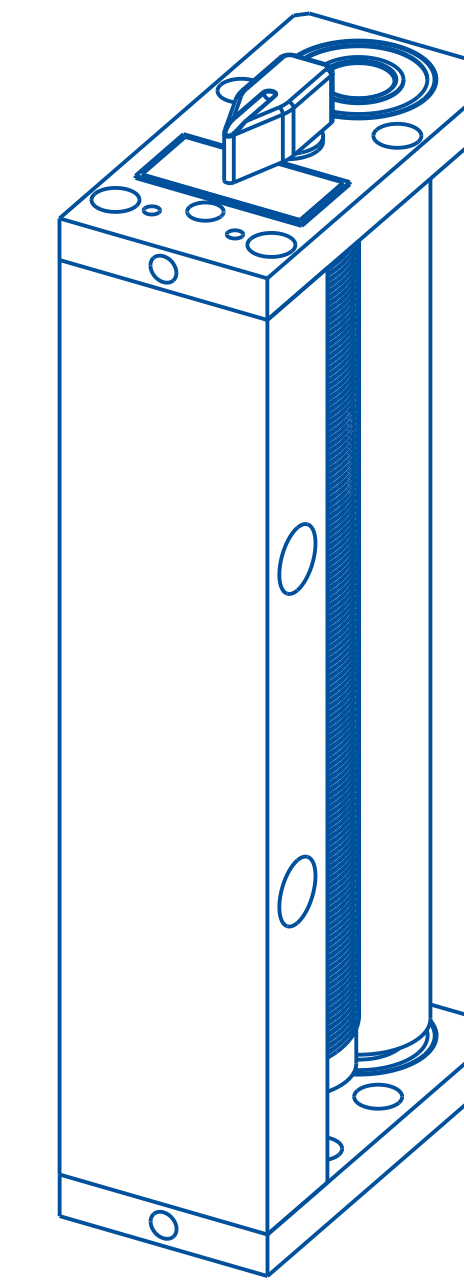
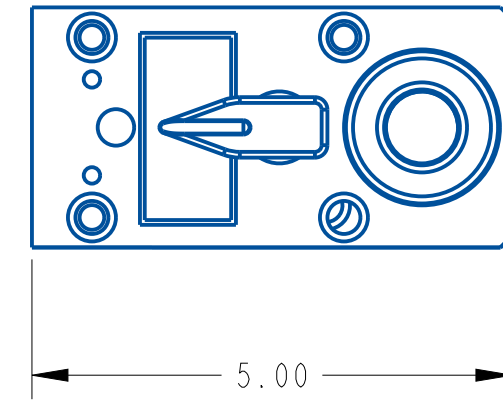

REV	DATE	DESCRIPTION	BY
A	Oct-13-25	NEW DRAWING	RDL

THIS IS A PRO-ENGINEER DOCUMENT AND MAY NOT BE MODIFIED MANUALLY

UNLESS OTHERWISE SPECIFIED
DIMENSIONAL TOLERANCE

X ± .1
XX ± .01
XXX ± .005
ANGLES ± .30°

SURFACE FINISH 125
BREAK ALL EDGES .005/ .015
CORNER RADIUS .010/ .030
ALL ANGLES ARE 90°

QUADREL LABELING SYSTEMS
7670 JENTHER DRIVE
MENTOR, OHIO 44060
(440) 602-4700

SCALE: 1/2
DATE: Oct-13-25
DRW BY: RDL
CHK BY:
APPR BY:

10" DRIVE ROLL ASSEMBLY

MAT'L

23100DR-010RH

ITEM	QTY	PART NO.	DESCRIPTION	PARENT ITEM
1	2	00301-17	SPRING, .275 x .052 x .94	23100DR-010LH
2	2	111072-000	BEARING, BALL	23100DR-010LH
3	3	151004-000	BEARING, THRUST WASHER	23100DR-010LH
4	1	362161-000	COLLAR, SETSCREW, 1/2 IN. ID	23100DR-010LH
5	1	791789-000	NAMEPLATE	23100DR-010LH
6	1	21701DY-000_LH	3 PIECE ROLL ASSEMBLY	23100DR-010LH
7	1	A20507-000	SPACER	23100DR-010LH
8	2	A20567-000	WHITE NYLON SLUG	23100DR-010LH
9	1	A20929-000	PINCH POINT GUARD ROD 12" WEB	23100DR-010LH
10	2	A23125-000	SPACER	23100DR-010LH
11	1	A25250-000	IND KNOB	23100DR-010LH
12	1	B20342-000	PULL ROLL, 10"	23100DR-010LH
13	1	B20344-000	KNURLED ROLL	23100DR-010LH
14	1	B20346-000	KNURLED ROLL SHAFT, 12"	23100DR-010LH

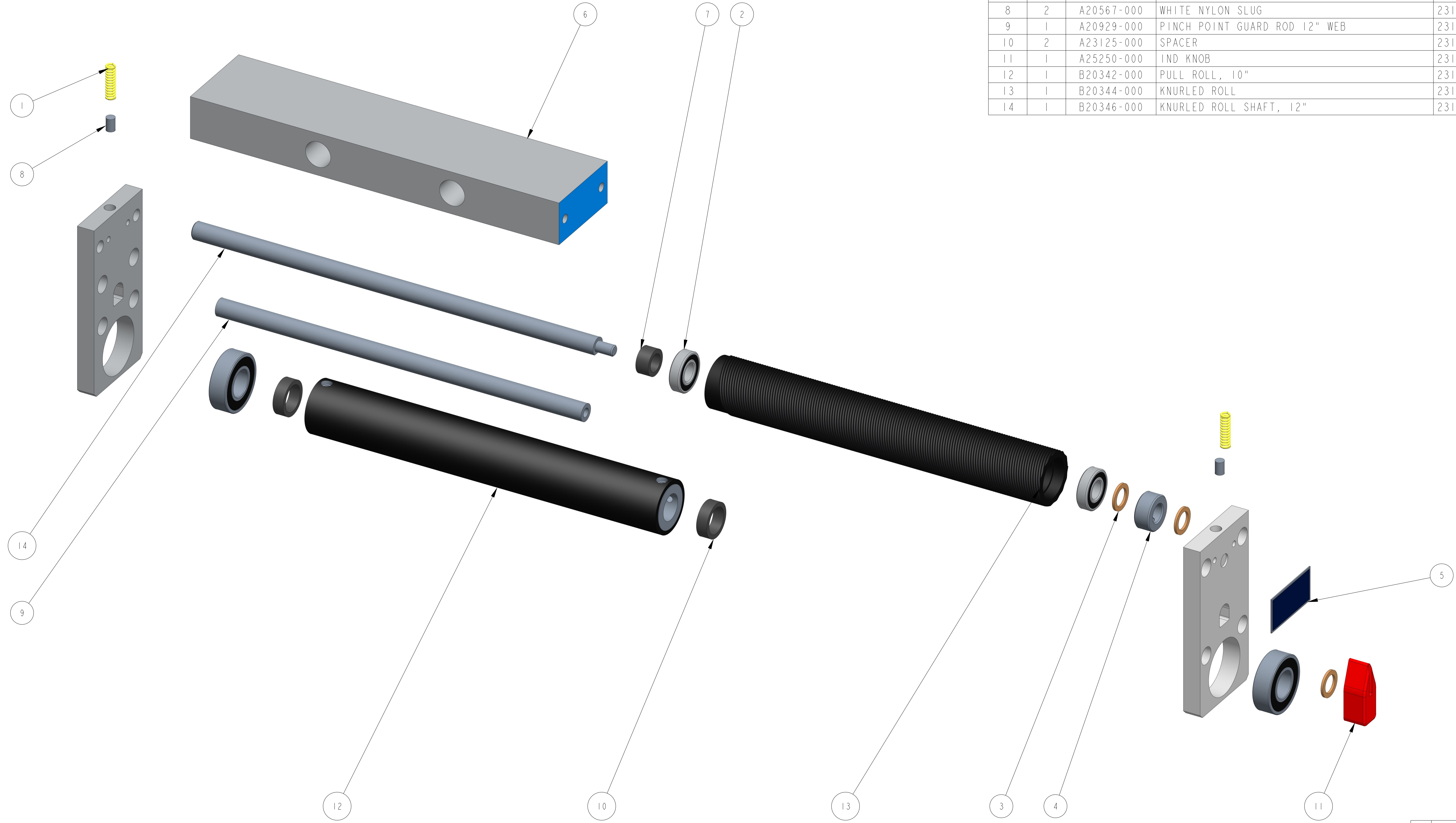

REV	DATE	DESCRIPTION	BY
A	10/17/25	NEW DRAWING	SEM

THIS IS A PRO-ENGINEER DOCUMENT AND MAY NOT BE MODIFIED MANUALLY

UNLESS OTHERWISE SPECIFIED
 DIMENSIONAL TOLERANCE
 .XX ± .01
 .XXX ± .005
 ANGLES ± 30°
 SURFACE FINISH 125
 BREAK ALL EDGES .005/0.15
 CORNER RADIUS .010/0.30
 ALL ANGLES ARE 90°

QUADREL LABELING SYSTEMS
 7670 JENTHER DRIVE
 MENTOR, OHIO 44060
 (440) 602-4700

SCALE: 3/4
 DATE: 10/17/25
 DRW BY: SEM
 CHK BY: &CREO.CHK
 APPR BY:

DRIVE ROLL ASSEMBLY, 10"

MAT'L: 23100DR-010LH

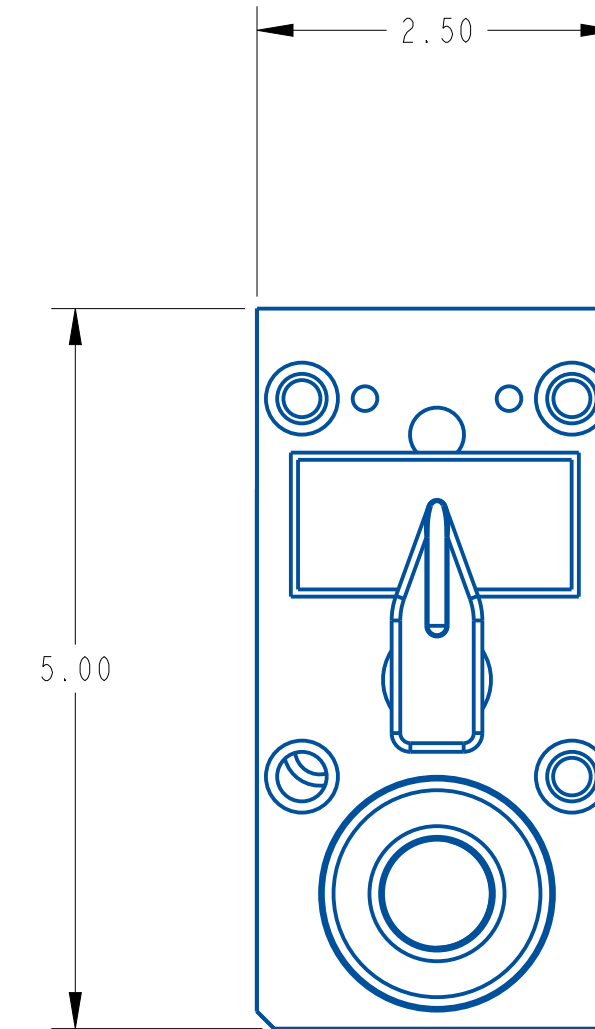
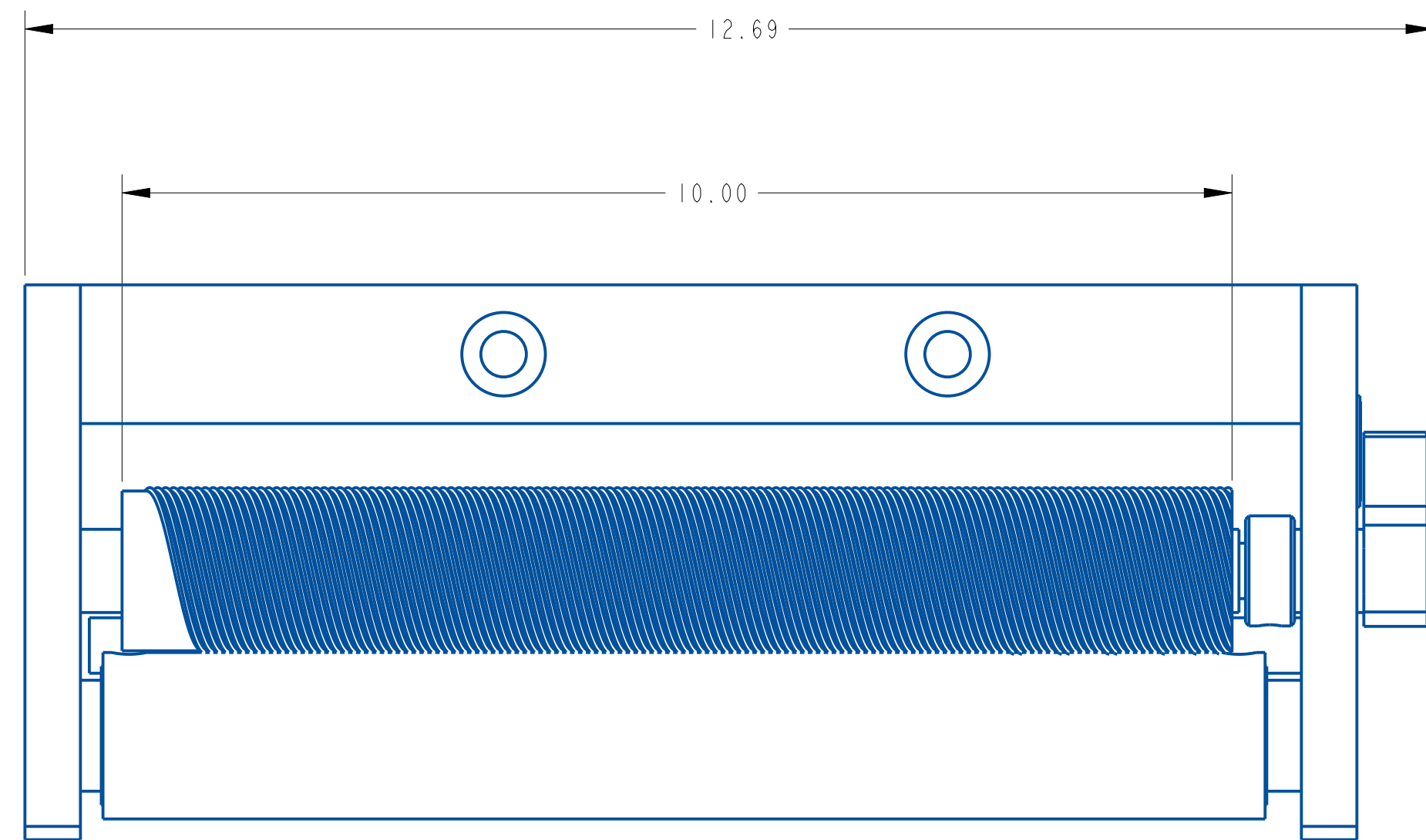
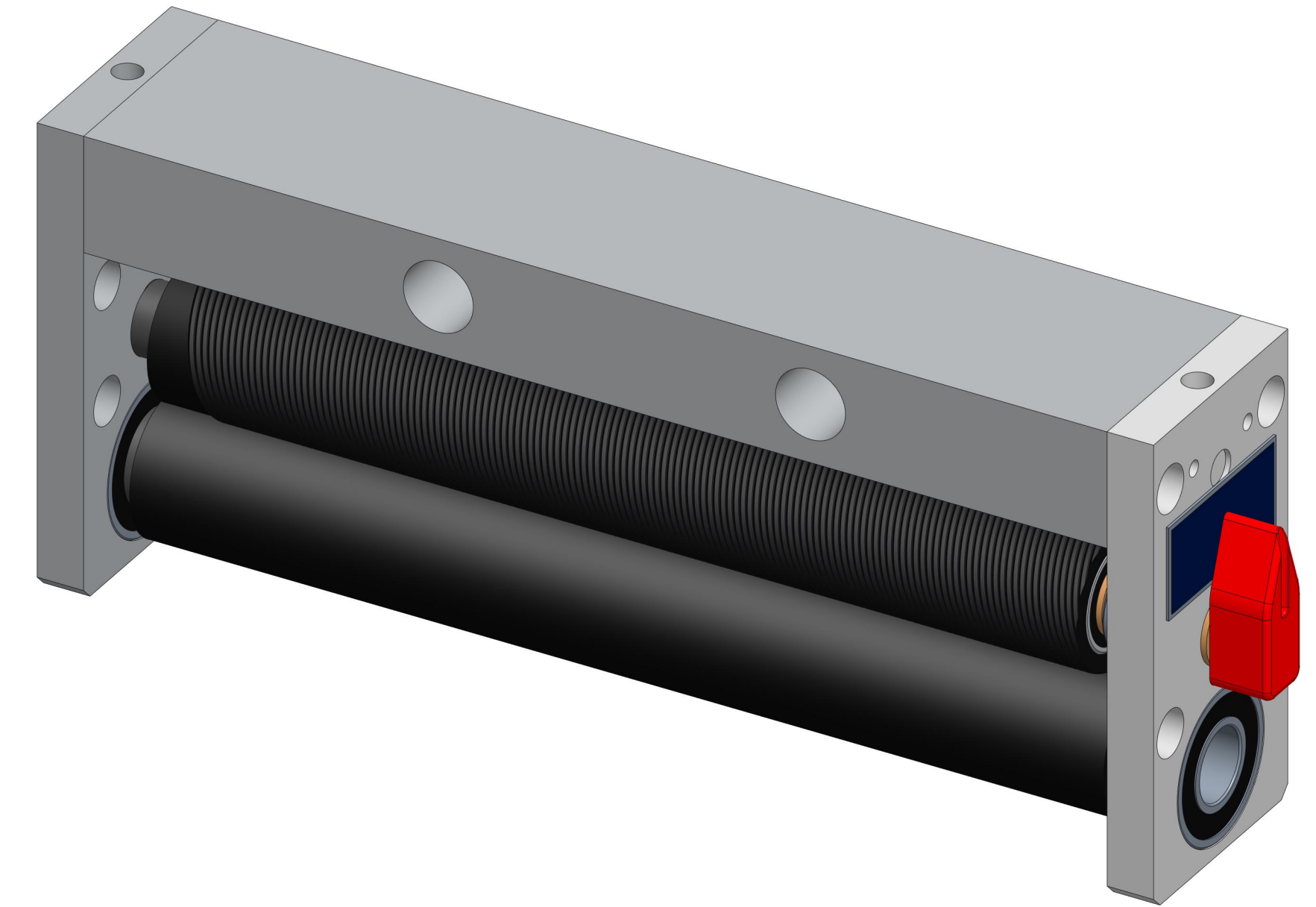

REV	DATE	DESCRIPTION	BY
A	SEM	NEW DRAWING	SEM

THIS IS A PRO-ENGINEER DOCUMENT AND MAY NOT BE MODIFIED MANUALLY

QUADREL LABELING SYSTEMS
 7670 JENTHER DRIVE
 MENTOR, OHIO 44060
 (440) 602-4700

SCALE: 3/4
 DATE: 10/17/25
 DRW BY: SEM
 CHK BY: &CREO_CHK
 APPR BY:

DRIVE ROLL ASSEMBLY, 10"

MAT'L 21915D-001 23100DR-010LH

ITEM	QTY	PART NO.	DESCRIPTION	PARENT ITEM
1	1	191592-000	BELT, TIMING, 1/2P	23120D-010LH
2	1	363157-000	COUPLING	23120D-010LH
3	1	412108-000	MOTOR, STEPPER 2 STACK, HITORQ	23120D-010LH
4	4	A20568-005	DRIVE MOTOR RISER	23120D-010LH
5	1	A21421-000	DRIVE PULLEY (MODIFIED)	23120D-010LH
6	1	C20097-621	PULL ROLL DRIVE SHAFT	23120D-010LH

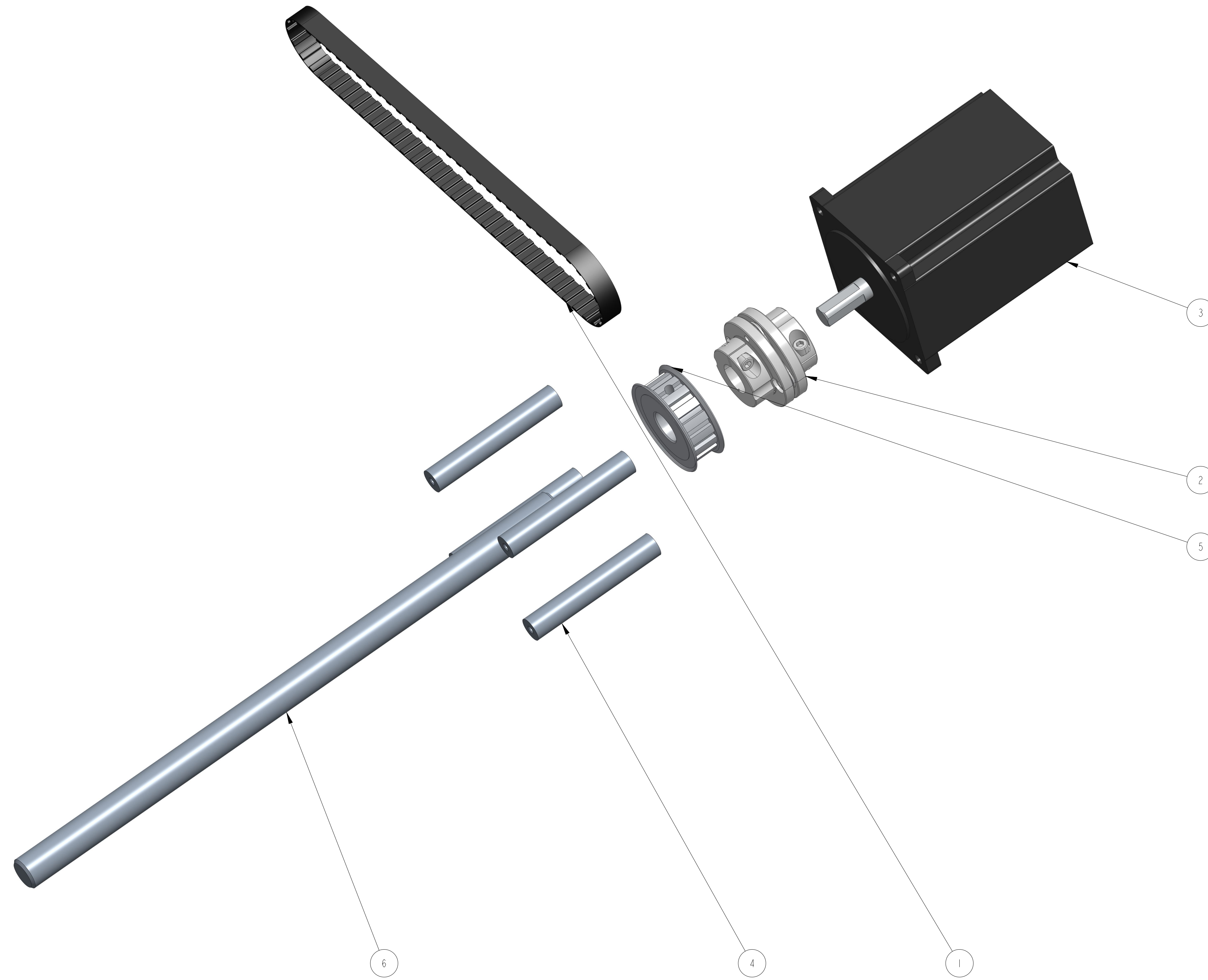

REV	DATE	DESCRIPTION	BY
A	Oct-06-25	NEW DRAWING	RDL

THIS IS A PRO-ENGINEER DOCUMENT AND MAY NOT BE MODIFIED MANUALLY

<small>UNLESS OTHERWISE SPECIFIED DIMENSIONAL TOLERANCE</small> xx ± .01 xxx ± .005 ANGLES ± .30° SURFACE FINISH 125 BREAK ALL EDGES .005/ .015 CORNER RADIUS .010/ .030 ALL ANGLES ARE 90°	 QUADREL LABELING SYSTEMS 7670 JENTHER DRIVE MENTOR, OHIO 44060 (440) 602-4700	SCALE: 3/4
		DATE: Oct-06-25
		DRW BY: RDL
		CHK BY: SEM
STEPPER DRIVE ASSEMBLY, 10"		MATERIAL: 23120D-010LH

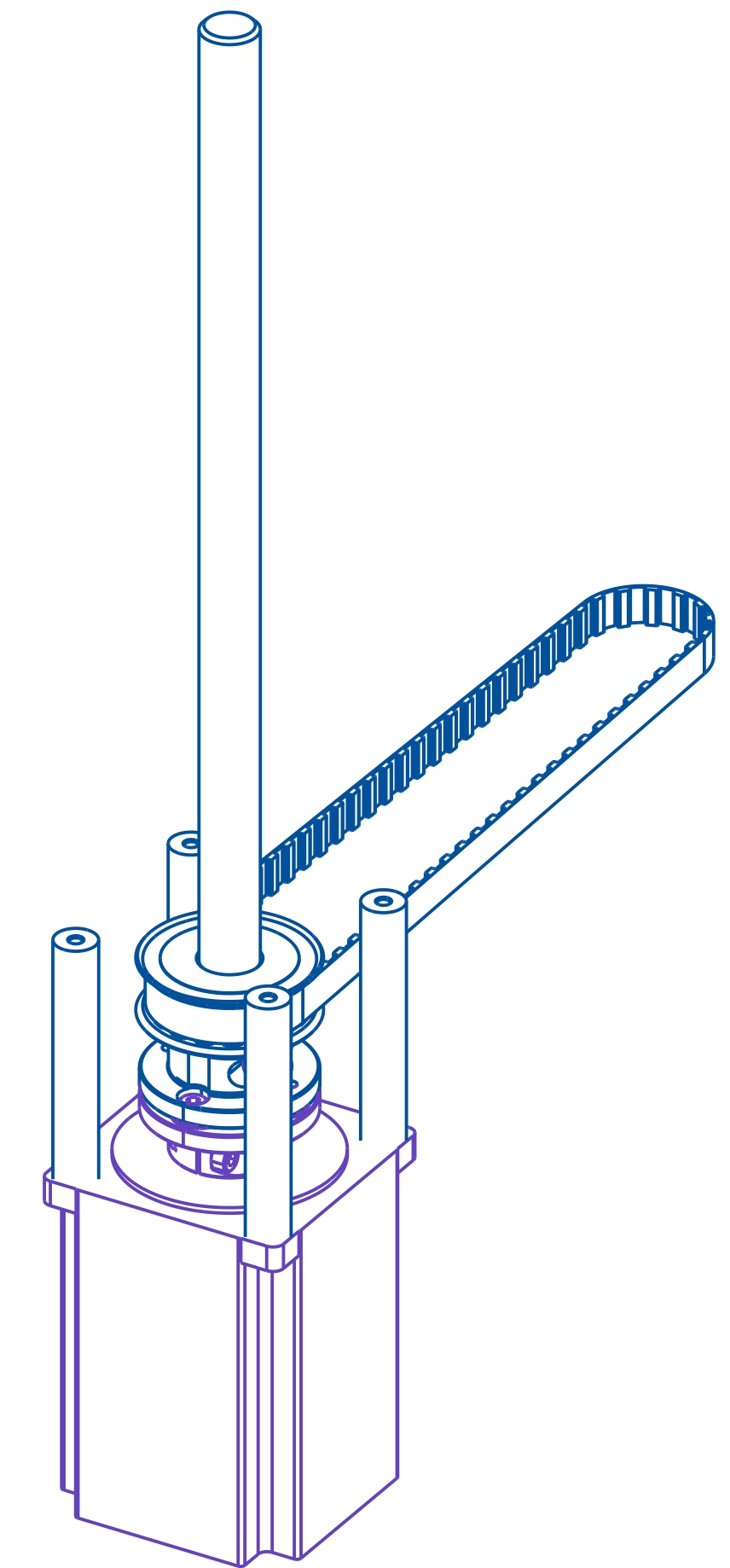
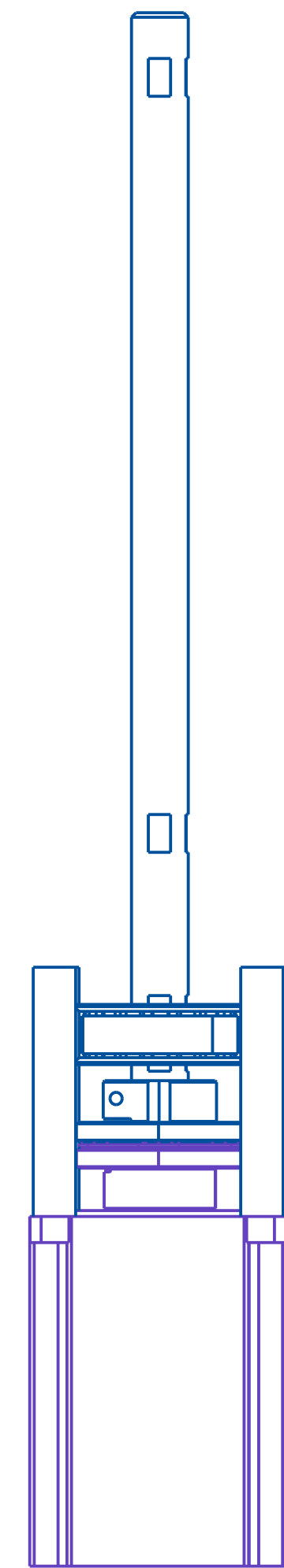
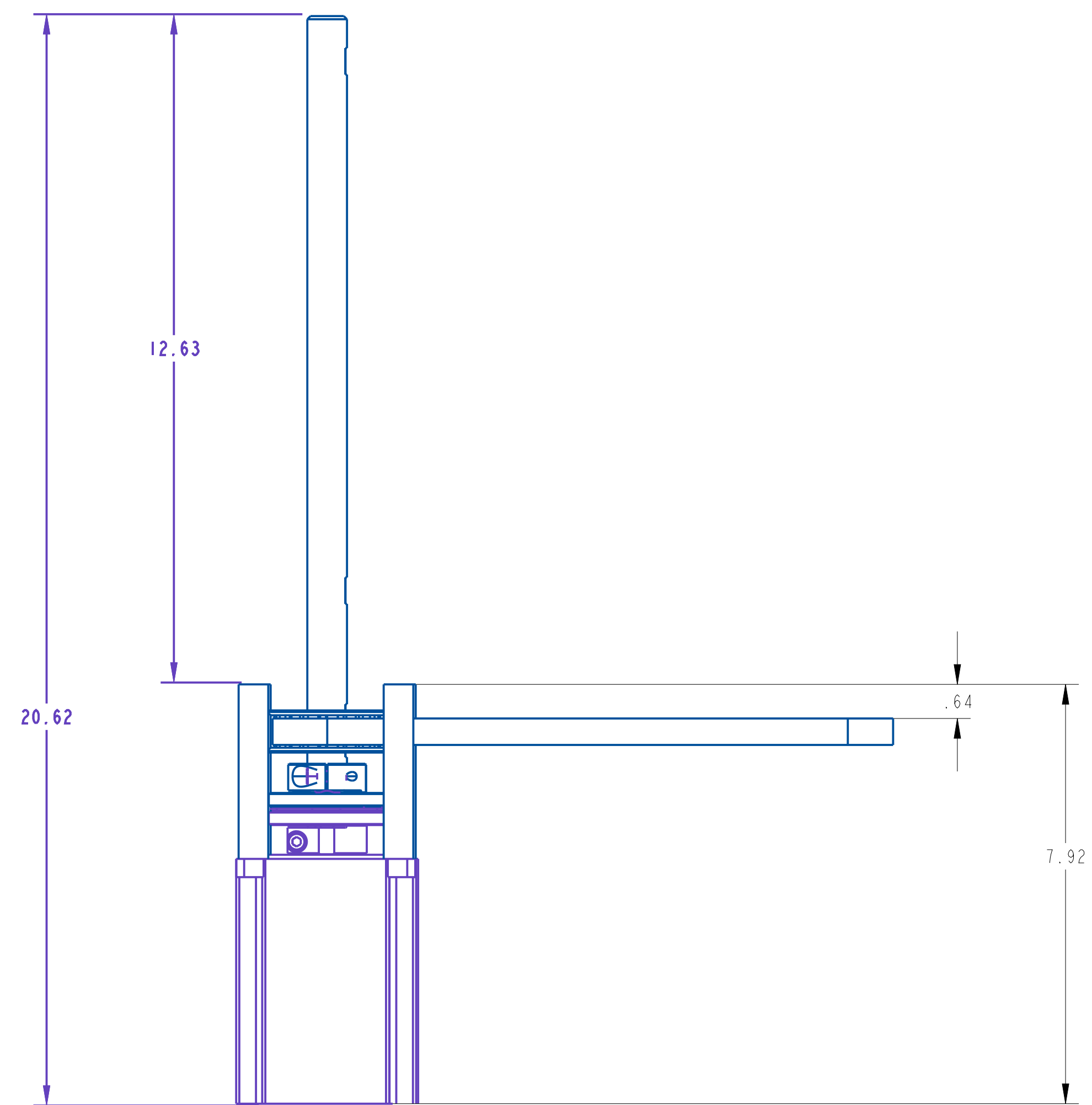
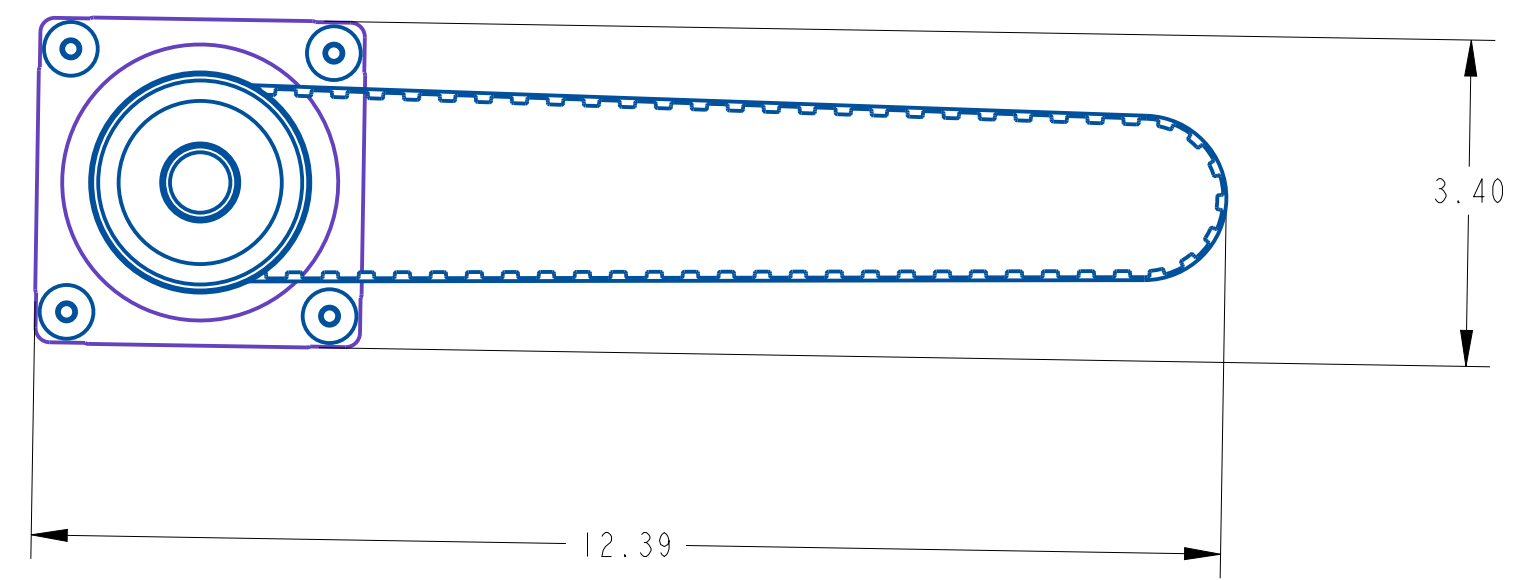

REV	DATE	DESCRIPTION	BY
A	Oct-06-25	NEW DRAWING	RDL

THIS IS A PRO-ENGINEER DOCUMENT AND MAY NOT BE MODIFIED MANUALLY

UNLESS OTHERWISE SPECIFIED DIMENSIONAL TOLERANCE	X ± .1 XX ± .01 XXX ± .005 ANGLES ± .30° SURFACE FINISH 125 BREAK ALL EDGES .005/ .015 CORNER RADIUS .010/ .030 ALL ANGLES ARE 90°	QUADREL LABELING SYSTEMS 7670 JENTHER DRIVE MENTOR, OHIO 44060 (440) 602-4700	SCALE: 1/2 DATE: Oct-06-25 DRW BY: RDL CHK BY: APPR BY:
---	---	---	---

STEPPER DRIVE ASSEMBLY, 10"

MAT'L	23120D-010LH
-------	--------------

STRAC8

AC Input Step Motor Drive



Hardware Manual

Applied Motion Products, Inc.

Contents

1	Introduction.....	3
1.1	Features.....	3
1.2	Block diagram.....	4
2	Mounting the Drive.....	4
3	Connections.....	5
3.1	Connecting to Power.....	6
3.2	Connecting to a Motor.....	7
3.3	Connecting the Inputs and Outputs.....	9
3.3.1	Step & Direction Inputs.....	9
3.3.2	EN input.....	10
3.3.3	Fault Output.....	11
4	Switch Selection.....	12
4.1	Microstep Resolution.....	12
4.2	Running Current.....	13
4.3	Idle Current.....	13
4.4	Anti Resonance.....	14
4.5	Step Input Mode.....	14
4.6	Step Input Signal Filter.....	14
4.7	Step Smoothing Filter.....	14
4.8	Self Test.....	14
5	Motor selection.....	15
5.1	Recommended motors.....	16
5.2	Torque-Speed Curves.....	16
6	Error Codes.....	18
7	Reference Materials.....	19
7.1	Mechanical Outline.....	19
7.2	Specifications.....	20
7.2.1	Electrical Specifications.....	20
7.2.2	Environmental Specifications.....	20
8	Contacting Applied Motion Products.....	21

1 Introduction

Thank you for selecting the Applied Motion Products' STRAC8 Step Motor Drive. The STRAC8 series AC input drives are based on advanced digital current control technology and provide high torque, low noise and low vibration. Many of the operational parameters are switch selectable. We hope our dedication to performance, quality and economy will make your motion control project successful.

1.1 Features

- Advanced digital current control provides excellent high speed torque
- Auto Setup measures motor parameters and configures motor current control and anti-resonance gain settings
- Uses universal AC input 90 to 240 VAC
- Speed Range - up to 50 rps
- Microstep Resolution - switch selectable, 16 settings: 200, 400, 800, 1600, 3200, 6400, 12800, 25600, 1000, 2000, 4000, 5000, 8000, 10000, 20000, 25000 steps/rev
- Running Current - peak setting, switch selectable, 16 settings: 0.4, 0.6, 0.9, 1.2, 1.5, 2.0, 2.5, 3.0, 3.5, 4.0, 4.5, 5.2, 5.9, 6.6, 7.3, 8.0A
- Idle Current - automatic reduction of running current 1 second after the motor stops, switch selectable, 4 settings: 25%, 50%, 70%, 90% of running current
- Anti Resonance - raises the system-damping ratio to eliminate midrange instability and allow stable operation throughout the speed range of the motor, switch selectable, 4 settings for low to high inertia loads
- Control Modes - Step/Direction pulse input or CW/CCW pulse input, switch selectable
- Input Signal Filter - filters out unwanted noise that can cause extra steps, switch selectable, 2MHz or 150KHz
- Step Smoothing Filter (Microstep Emulation) - performs high resolution stepping by synthesizing coarse steps into fine micro-steps, switch selectable, ON or OFF
- Self Test - performs a 2 rev, 0.5RPS, CW/CCW move test, switch selectable, ON or OFF
- Motor Selection - a 16 bit rotary switch is used to select the desired motor database which is pre-loaded at the Factory

1.2 Block diagram

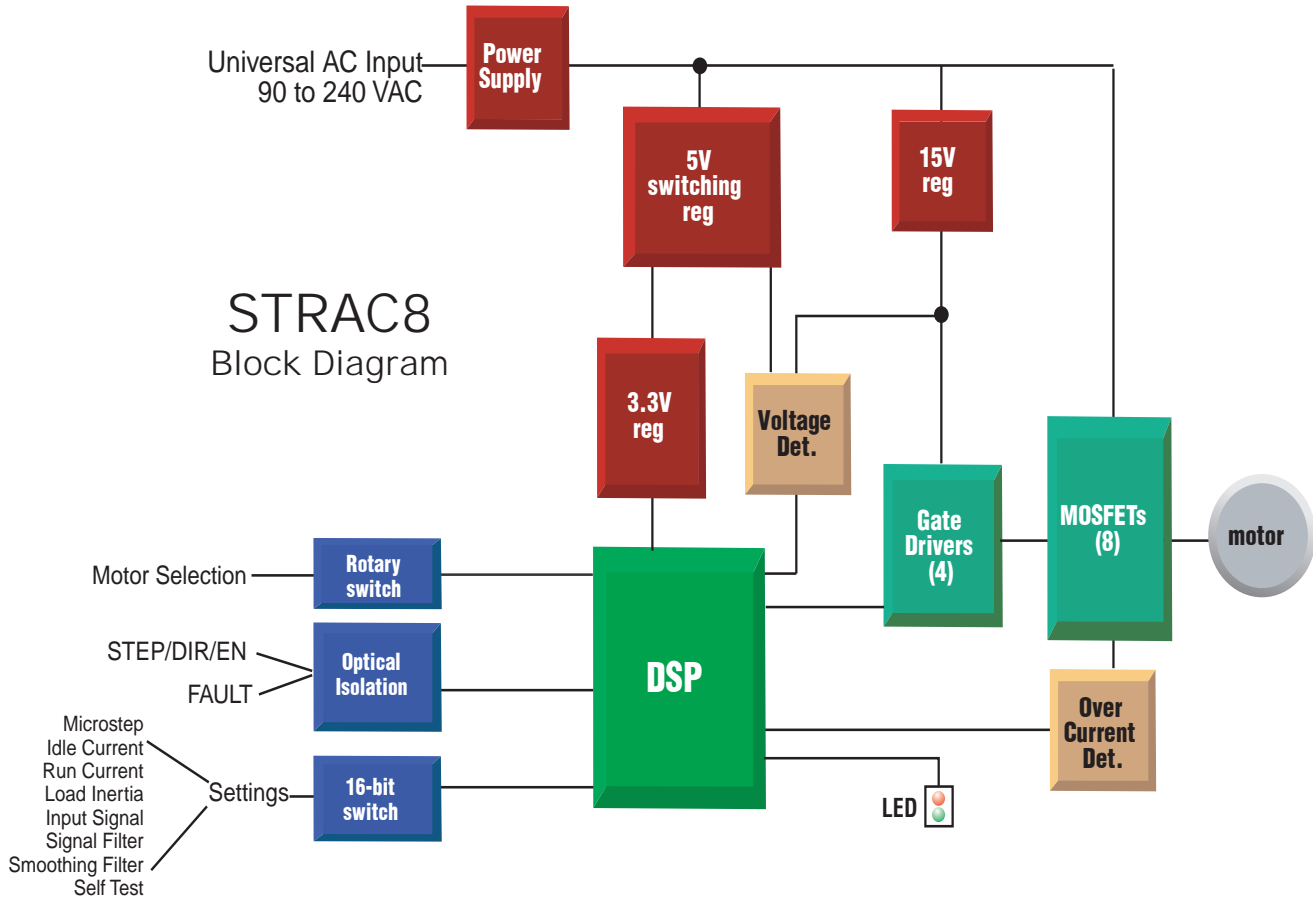

2 Mounting the Drive

The STRAC8 drive can be mounted only on the narrow side of the chassis. M4 screws should be used in the two holes at the back of the drive.

The amplifiers in the drive generate heat. To operate the drive continuously at maximum power forced air cooling, as from a fan, should be provided.

Never use the drive in a space where there is no air flow or where other devices can cause the surrounding air to be more than 40 °C. Never put the drive where it can get wet or where metal particles can fall into it.

3 Connections

To use the STRAC8 Step Drive, the following items are needed:

- Universal AC input of 90 to 240 VAC
- Pulse & Direction signal
- A compatible step motor

STRAC8 Wiring Diagram

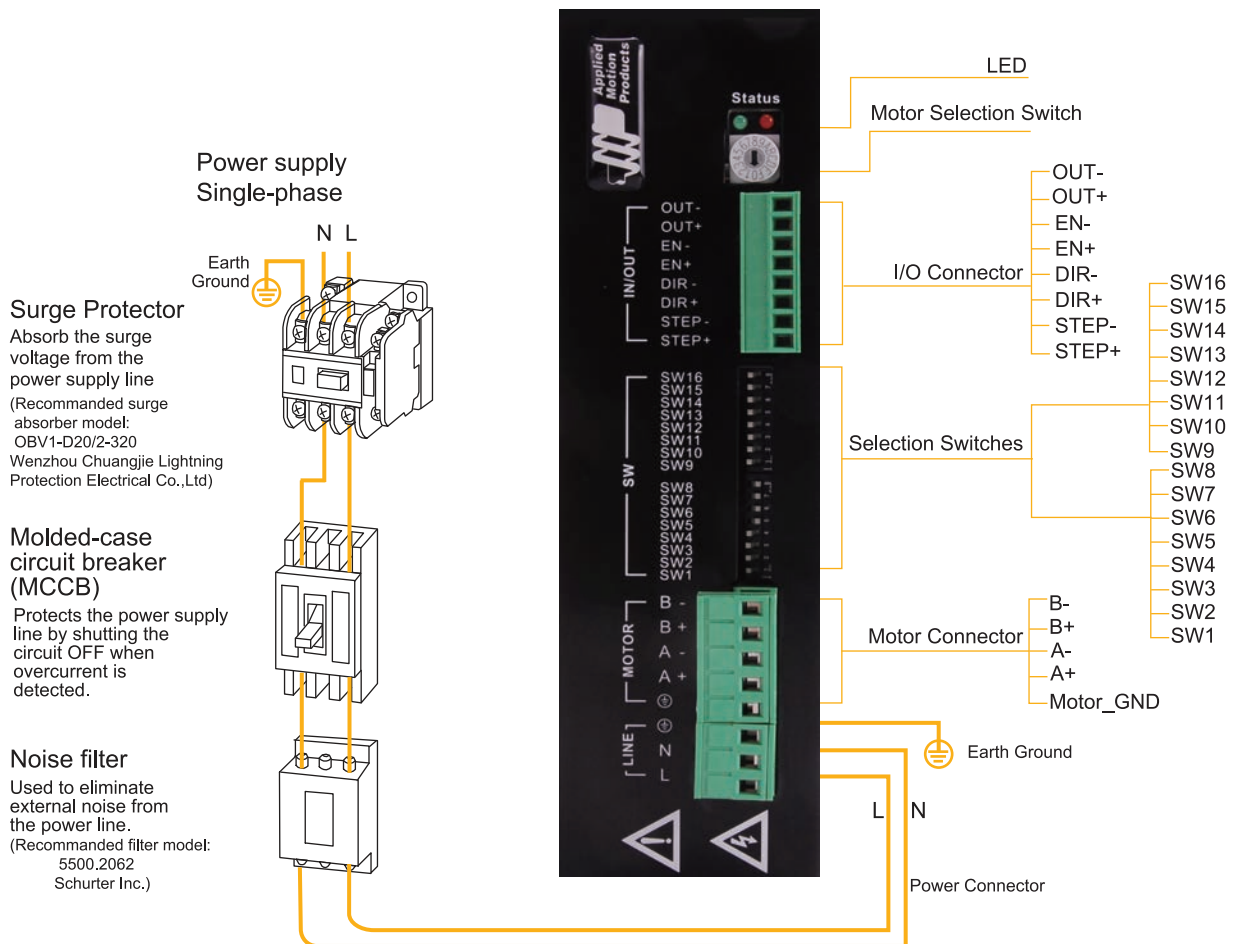

3.1 Connecting to Power

Use the supplied connector to connect to the AC supply according to the diagram below. Use 16 AWG wire for Line (L) and Neutral (N). Use 14 AWG for Earth Ground (G).

Care should always be taken when working with high voltages.

In regions where the single-phase supply is higher, an auto transformer can be used to drop the voltage to the correct level.

The STRAC8 contains an internal 10A fast acting fuse.

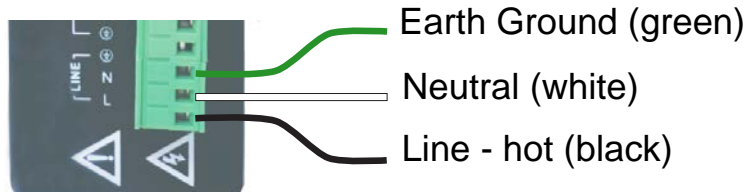

Regeneration Clamping Circuit

High speed motion generates high voltage which can be transferred to the drive during rapid deceleration, and the drive may indicate an over-voltage error condition after stopping from a high speed motion. The STRAC8 has regeneration clamping circuitry with an internal 200ohm 10W resistor. To protect the drive in a high speed, high load inertia application Applied Motion Products' recommends connecting an external 80ohm 80W resistor to the regen connector located on the side of the STRAC8 drive.

External Resistor Connector

Housing: 39-01-3028(MOLEX)



Crimp: 39-00-0038(MOLEX)



3.2 Connecting to a Motor

Motor connections should be made according to the following diagrams.

Never connect or disconnect the motor while the power is on.

Note: it is highly recommended that you use a motor with a shielded cable with the STRAC8. Always connect the cable drain wire to the drive's \ominus terminal (next to the A+ terminal)

The recommended Applied Motion motors for the STRAC8 include shielded cables. See the Recommended Motors section for a list of part numbers. The recommended motors should be connected to 120V drives in parallel, and to 220V drives in series, according to the diagram below.

Be sure to connect the cable shield for safety and to minimize electrical interference.

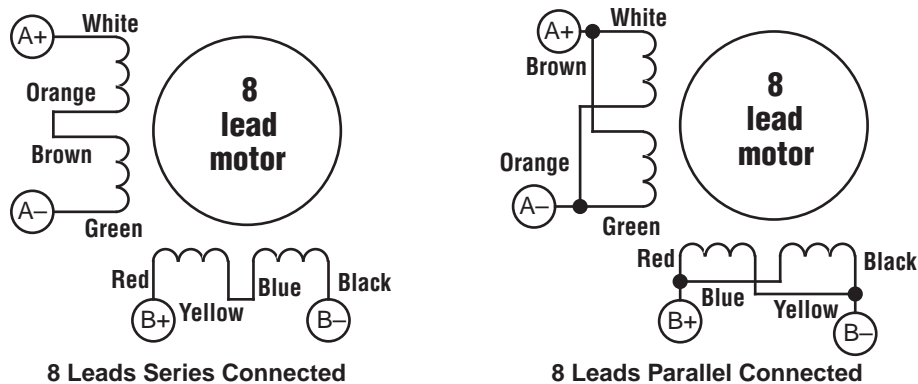

Connecting Other Motors

Four lead motors can only be connected one way. Please follow the sketch at the right.

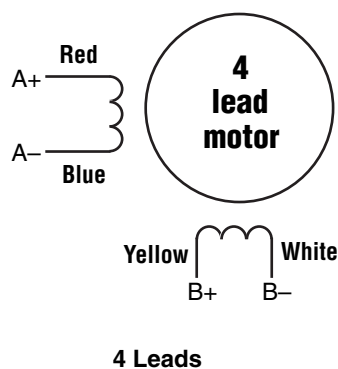

Six lead motors can be connected in series or center tap. In series mode, motors produce more torque at low speeds, but cannot run as fast as in the center tap configuration. In series operation, the motor should be operated at 30% less than the rated current to prevent overheating. Winding diagrams for both connection methods are shown below. NC means not connected.

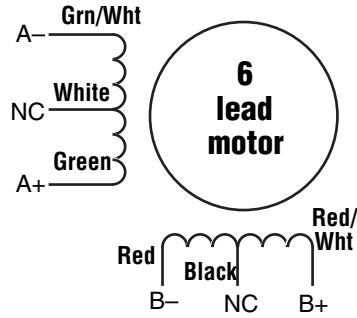

6 Leads Series Connected

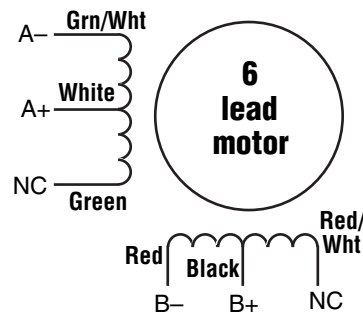

6 Leads Center Tap Connected

Eight lead motors can also be connected in two ways: series and parallel. As with six lead motors, series operation gives you less torque at high speeds, but may result in lower motor losses and less heating. In series operation, the motor should be operated at 30% less than the unipolar rated current. The wiring diagrams for eight lead motors without shielded cables are shown below.

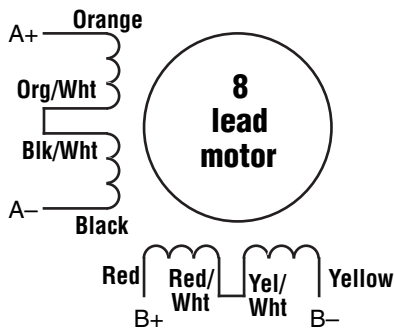

8 Leads Series Connected

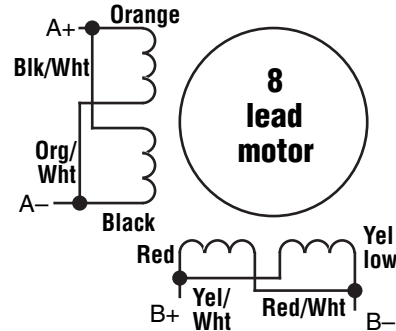

8 Leads Parallel Connected

3.3 Connecting the Inputs and Outputs

3.3.1 Step & Direction Inputs

The STRAC8 Step Drive has two high speed optically isolated inputs called STEP and DIR. They accept 5 to 24 volt single-ended or differential signals, up to 2MHz. The maximum voltage that can be applied to the input is 28V.

The motor executes one step when the STEP input closes.

The direction of rotation is controlled by the DIR input state. A closed input (logic "0") will result in clockwise rotation, and an open input (logic "1") will result in counterclockwise rotation.

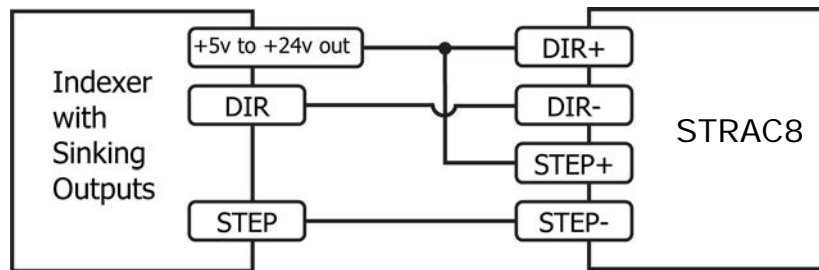

Connecting to Indexer with Sinking Outputs

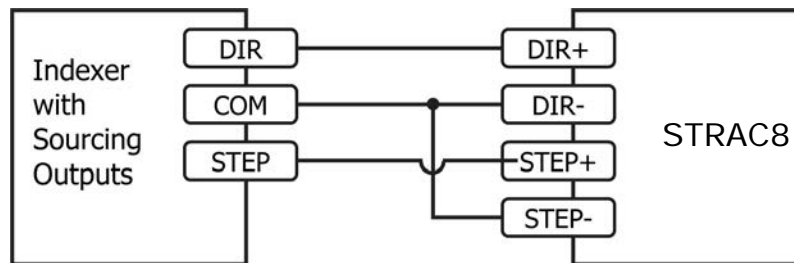

Connecting to Indexer with Sourcing Outputs

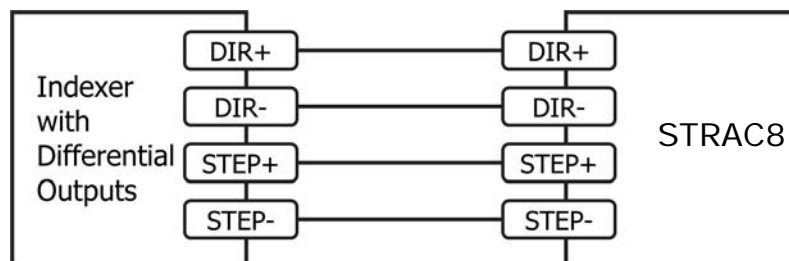

Connecting to Indexer with Differential Outputs
Many high-speed indexers have differential outputs

3.3.2 EN input

The EN input enables or disables the drive amplifier. It is an optically isolated input that accepts a 5 to 24 volt single-ended or differential signal. The maximum voltage that can be applied to the input is 28V.

When EN input is closed, the driver amplifier is deactivated, all the MOSFETs will shut down, and the motor will be free. When EN input is open, the drive is activated.

When the drive has encountered an error and the fault is removed from the system, a falling signal into the EN input will reset the error status and activate the drive amplifier again.

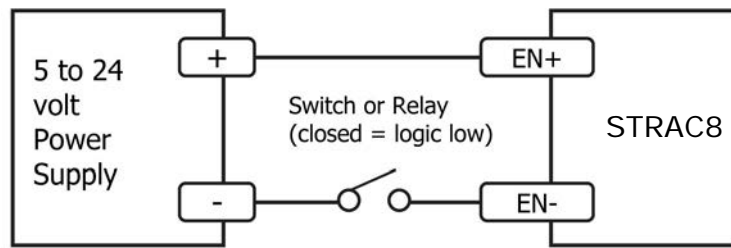

Connecting the Input to a Switch or Relay

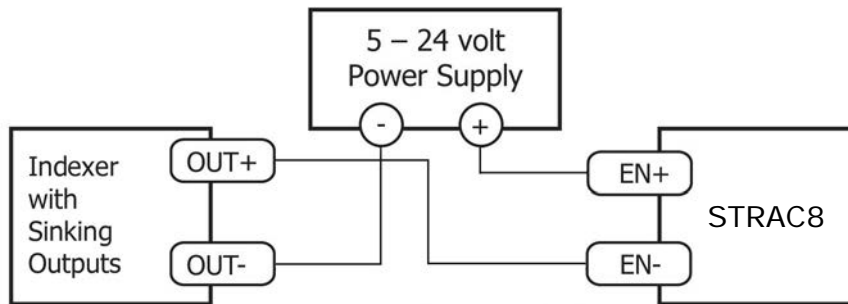

Connecting the Input to Sinking Outputs

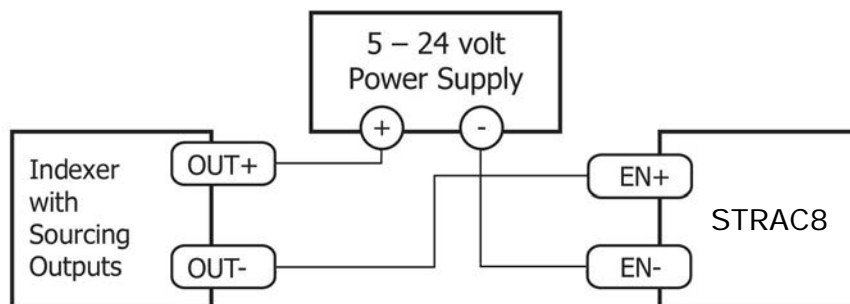

Connecting the Input to Sourcing Outputs

3.3.3 Fault Output

The FAULT Output is optically isolated. The maximum collector current is 100mA, and the maximum collector to emitter voltage is 30 volts. The output can be wired to sink or source current.

When drive is working normally, the output is open. When the drive encounters an error, the output closes.

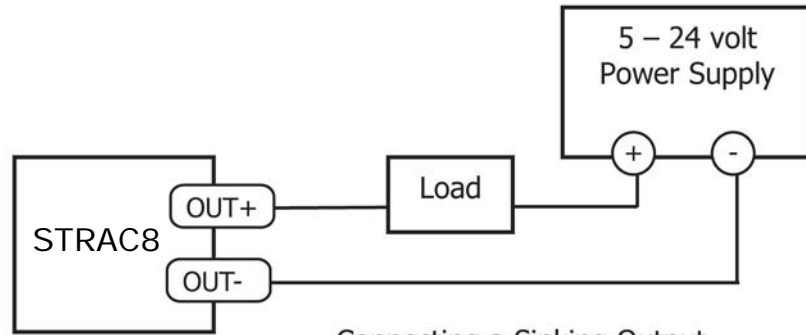

Connecting a Sinking Output

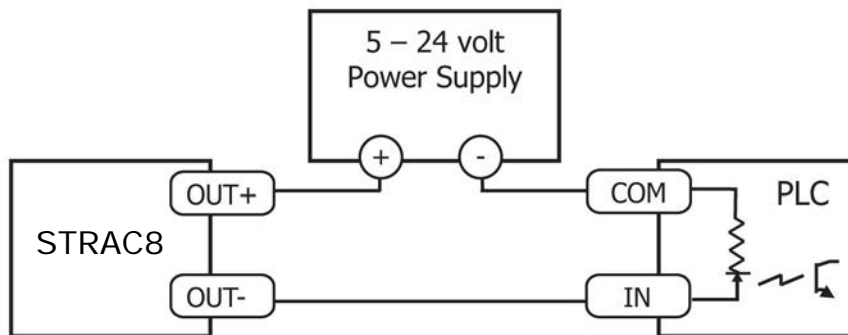

Connecting a Sourcing Output

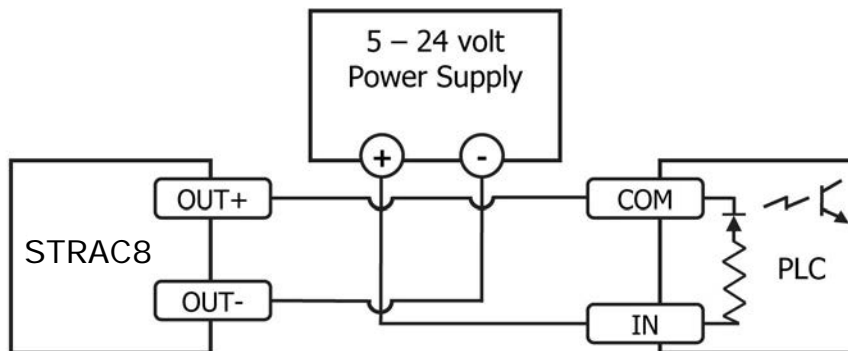

Connecting a Sourcing Output again

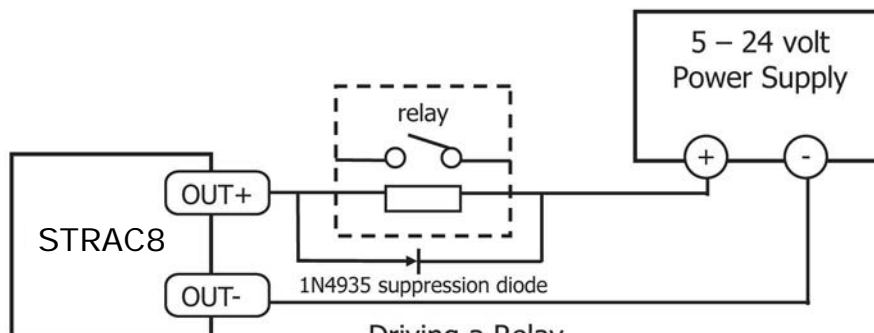

Driving a Relay

4 Switch Selection

Many of the operational parameters of the STRAC8 can be set or changed by position switches - either by a single switch or a combination of ON/OFF settings of 2 or more switches.

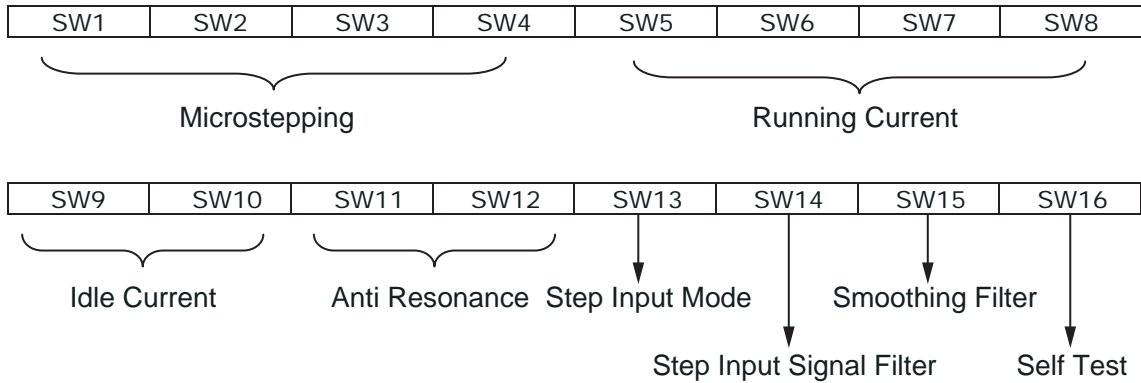

4.1 Microstep Resolution

The microstep resolution is set by the SW1, SW2, SW3 and SW4 switches. There are 16 settings.

Microstep(steps/rev)	SW1	SW2	SW3	SW4
200	ON	ON	ON	ON
400	OFF	ON	ON	ON
800	ON	OFF	ON	ON
1600	OFF	OFF	ON	ON
3200	ON	ON	OFF	ON
6400	OFF	ON	OFF	ON
12800	ON	OFF	OFF	ON
25600	OFF	OFF	OFF	ON
1000	ON	ON	ON	OFF
2000	OFF	ON	ON	OFF
4000	ON	OFF	ON	OFF
5000	OFF	OFF	ON	OFF
8000	ON	ON	OFF	OFF
10000	OFF	ON	OFF	OFF
20000	ON	OFF	OFF	OFF
25000	OFF	OFF	OFF	OFF

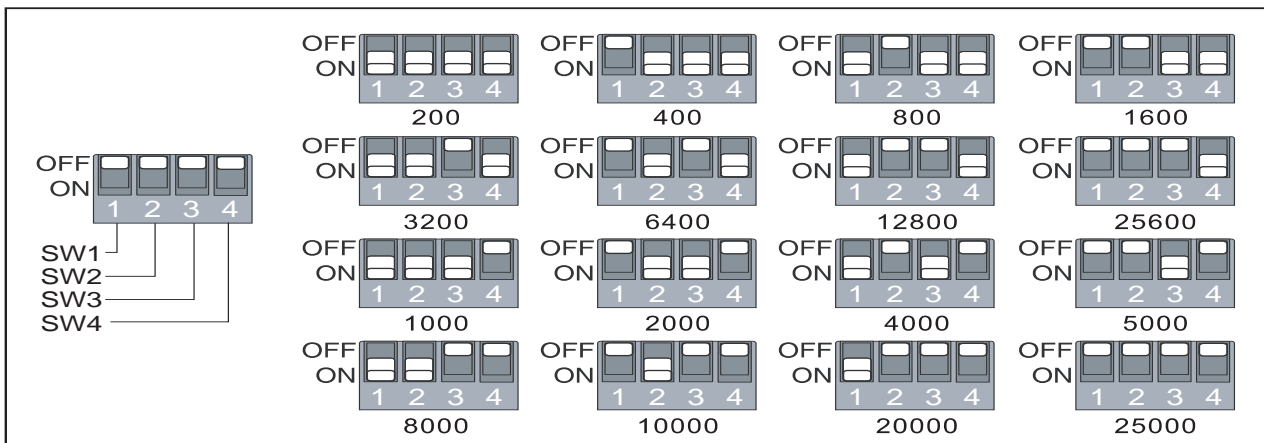

4.2 Running Current

The output current is set by the SW5, SW6, SW7 and SW8 switches. There are 16 settings.

NOTE: Drive's running current will be limited by the lower value between motor selection rotary switch and the dip current switch

Current (Peak)	SW5	SW6	SW7	SW8
0.4A	ON	ON	ON	ON
0.6A	OFF	ON	ON	ON
0.9A	ON	OFF	ON	ON
1.2A	OFF	OFF	ON	ON
1.5A	ON	ON	OFF	ON
2.0A	OFF	ON	OFF	ON
2.5A	ON	OFF	OFF	ON
3.0A	OFF	OFF	OFF	ON
3.5A	ON	ON	ON	OFF
4.0A	OFF	ON	ON	OFF
4.5A	ON	OFF	ON	OFF
5.2A	OFF	OFF	ON	OFF
5.9A	ON	ON	OFF	OFF
6.6A	OFF	ON	OFF	OFF
7.3A	ON	OFF	OFF	OFF
8.0A	OFF	OFF	OFF	OFF

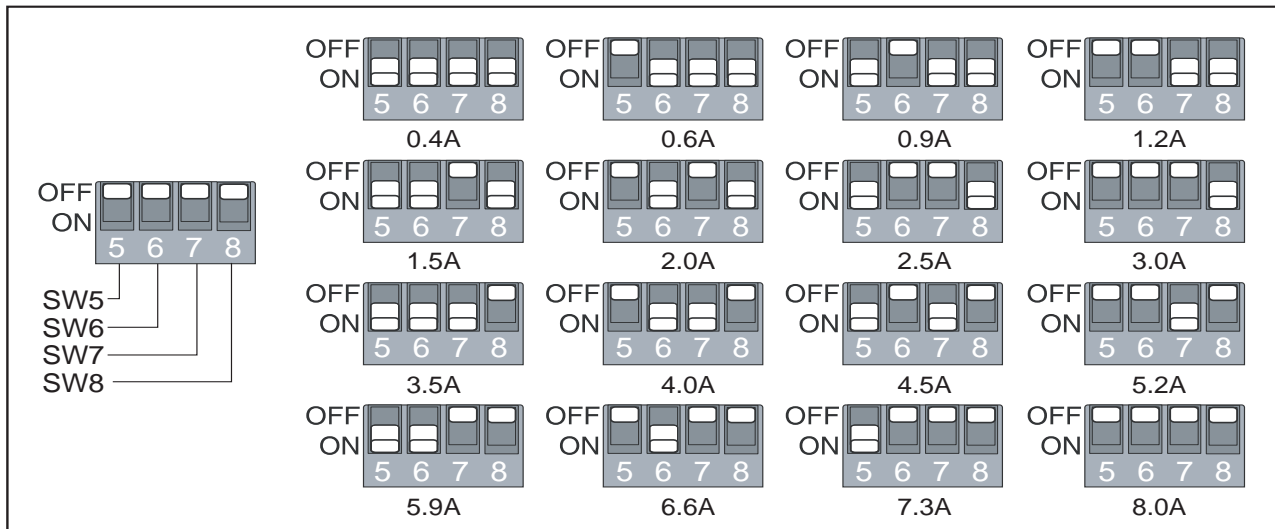

4.3 Idle Current

The running current of the STRAC8 drive is automatically reduced whenever the motor isn't moving. The SW9 and SW10 switches control the percentage of the running current the idle current is reduced to. The 90% setting is useful when a high holding torque is required. To minimize motor and drive heating it is highly recommended that the idle current reduction feature be set as low as the

Idle	SW9	SW10
25%	ON	ON
50%	OFF	ON
70%	ON	OFF
90%	OFF	OFF

application can tolerate.

4.4 Anti Resonance

The SW11 and SW12 switches select the load inertia. There are 4 settings. The inertia selection can help the STRAC8 drive to calculate the current control parameter. If the load inertia is close to that of the motor rotor, the low setting should be selected. If the load inertia is higher than that of the rotor, a proportionally higher setting should be selected.

Option	SW11	SW12	Inertia
0	ON	ON	Low ↓ High
1	OFF	ON	
2	ON	OFF	
3	OFF	OFF	

4.5 Step Input Mode

Most indexers and motion controllers provide motion commands in the Step and Direction format. The Step signal pulses once for each motor step and the Direction signal commands direction. Some PLCs use a CW/CCW command signal: one signal pulses once for each desired step in the clockwise direction (CW Step), while a second signal pulses for counterclockwise motion (CCW Step). In the CW/CCW control mode, the CW signal should be connected to the STEP input and the CCW signal to the DIR input.

Setting SW13 to OFF enables the Step & Direction format, the ON position enables the CW/CCW format.

Note: The power must be cycled each time the position of SW13 is changed.

4.6 Step Input Signal Filter

The STEP and DIR signal inputs have a built-in digital filter to reduce the external noise. If the system works on the low microstep, the 150 KHz setting should be selected. If the system works on the high microstep, the 2 MHz setting should be used.

The SW14 switch selects the digital signal filter. ON sets it to 150 KHz, OFF sets it to 2 MHz.

Note: The power must be cycled each time the position of SW14 is changed.

4.7 Step Smoothing Filter

Command signal smoothing can soften the effect of immediate changes in velocity and direction, making the motion of the motor less jerky. An added advantage is that it can reduce the wear on mechanical components. SW15 selects this function - ON enables it, OFF disables it.

This function can cause a small delay in following the control signal, and it should be used with that in mind.

Note: The power must be cycled each time the position of SW15 is changed.

4.8 Self Test

Setting SW16 to ON after the drive is powered up, will cause the drive to perform a Self Test move of 2 revolutions both CW and CCW at .5 rps. Setting SW16 to OFF will disable this feature.

5 Motor selection

Each position of the 16-bit rotary switch selects a different motor, and automatically sets the configuration parameters in the drive. The STRAC8 drive comes programmed with up to 16 typical motors as factory defaults. Drives can be customized with specially selected motors when required.

NOTE: Drive's running current will be limited by the lower value between motor selection rotary switch and the dip current switch

NOTE: When the motor selection is changed, the drive power supply will need to be cycled.

SW position	MOTOR	WIRING	Input Voltage	Input Voltage
0	Reserved	Reserved	0 A	
1	Reserved	Reserved	0 A	
2	HT23-552	Parallel	1.5 A	120VAC
3	HT23-553	Parallel	1.5 A	120VAC
4	HT23-554	Parallel	1.8 A	120VAC
5	HT34-495/695	Parallel	5.1 A	120VAC
6	HT34-496/696	Parallel	5.1 A	120VAC
7	HT34-497/697	Parallel	5.8 A	120VAC
8	HT23-552	Series	0.75 A	240VAC
9	HT23-553	Series	0.75 A	240VAC
A	HT23-554	Series	0.9 A	240VAC
B	HT34-495/695	Series	2.5 A	240VAC
C	HT34-496/696	Series	2.5 A	240VAC
D	HT34-497/697	Series	2.5 A	240VAC
E	Custom Motor	Reserved	8 A	120VAC/240VAC
F	Custom Motor	Reserved	8 A	120VAC/240VAC

5.1 Recommended motors

Recommended Motors - NEMA 23

Motor Part No.	STRAC8 (120)		STRAC8 (220)		Holding Torque oz-in	Rotor Inertia oz-in-sec ²	Motor Length inch (mm)
	Connection	Drive Current Setting amps/phase	Connection	Drive Current Setting amps/phase			
HT23-552	parallel	1.50	series	0.75	84.4	1.70E-03	1.71 (43.5)
HT23-553	parallel	1.50	series	0.75	167	4.25E-03	2.17 (55)
HT23-554	parallel	1.80	series	0.90	255	6.80E-03	3.05 (77.5)

Recommended Motors - NEMA 34

Motor Part No.	STRAC8 (120)		STRAC8 (220)		Holding Torque oz-in	Rotor Inertia oz-in-sec ²	Motor Length inch (mm)
	Connection	Drive Current Setting amps/phase	Connection	Drive Current Setting amps/phase			
HT34-495/695	parallel	5.10	series	2.55	555	2.27E-02	3.11 (79)
HT34-496/696	parallel	5.10	series	2.55	1110	4.53E-02	4.63 (117.5)
HT34-497/697	parallel	5.80	series	3.20	1694	6.80E-02	6.14 (156)

Note: The "Drive Current Setting" shown here differs from the rated current of each motor because the rated current is RMS and the drive current setting is peak sine. If you are using a motor not listed here, for best results set the drive current at the motor's rated current x 1.2.



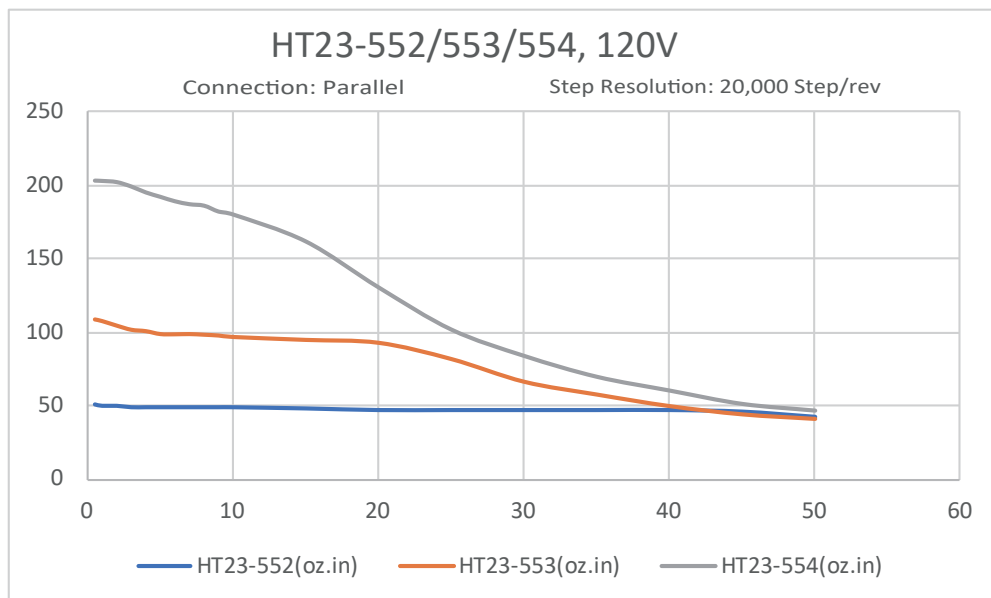

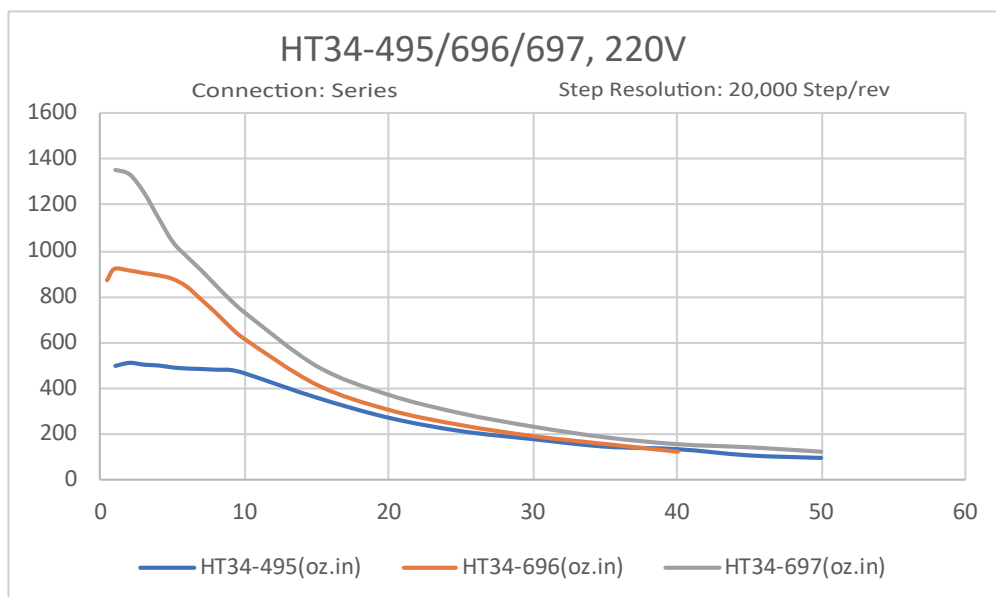
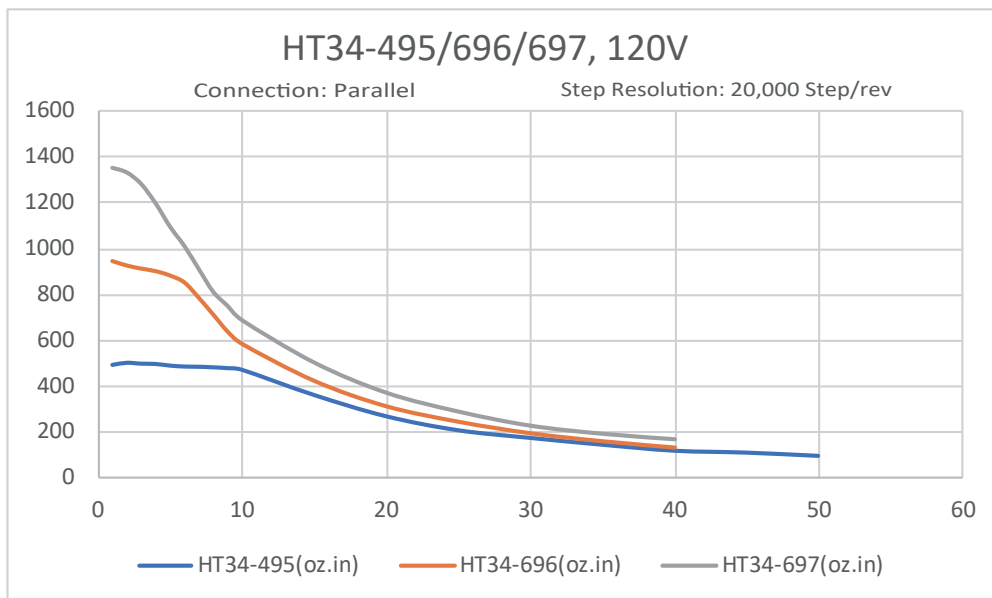
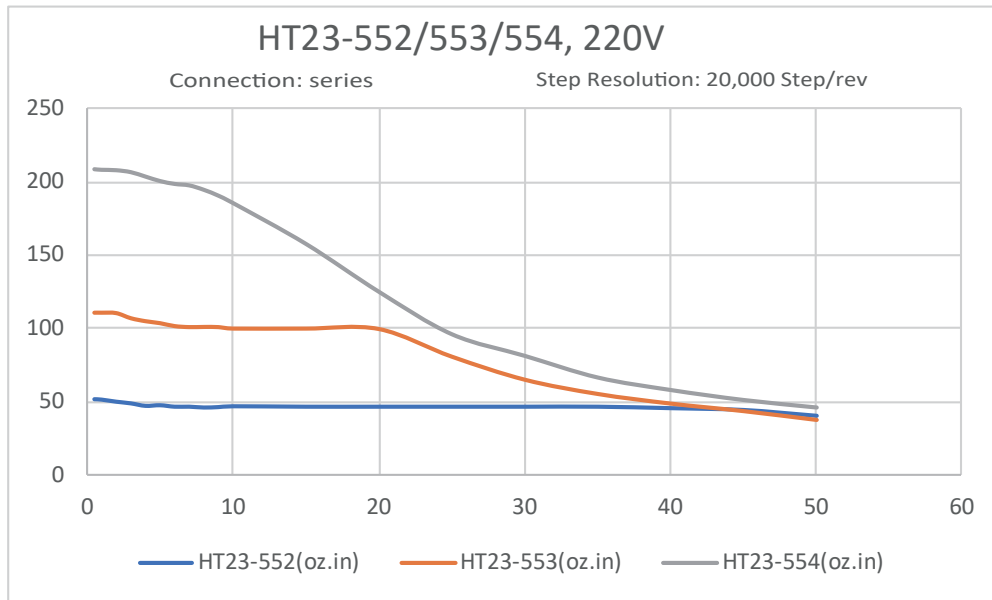



5.2 Torque-Speed Curves





6 Error Codes

The STRAC8 Drive has two LEDs to indicate status. When the motor is enabled the green LED flashes slowly, when the green LED is solid the motor is disabled. If the red LED flashes, an error has occurred. Errors are indicated by combinations of red and green flashes as shown below:

Code		Error
	Solid green	Motor Disabled
	Flashing green	Motor Enabled
	3 red, 1 green	Over Temperature
	3 red, 2 green	Bad Internal Voltage
	4 red, 1 green	Supply Voltage High
	4 red, 2 green	Supply Voltage Low
	5 red, 1 green	Over Current
	5 red, 2 green	Excess Regen
	6 red, 1 green	Open Motor Phase

7 Reference Materials

7.1 Mechanical Outline

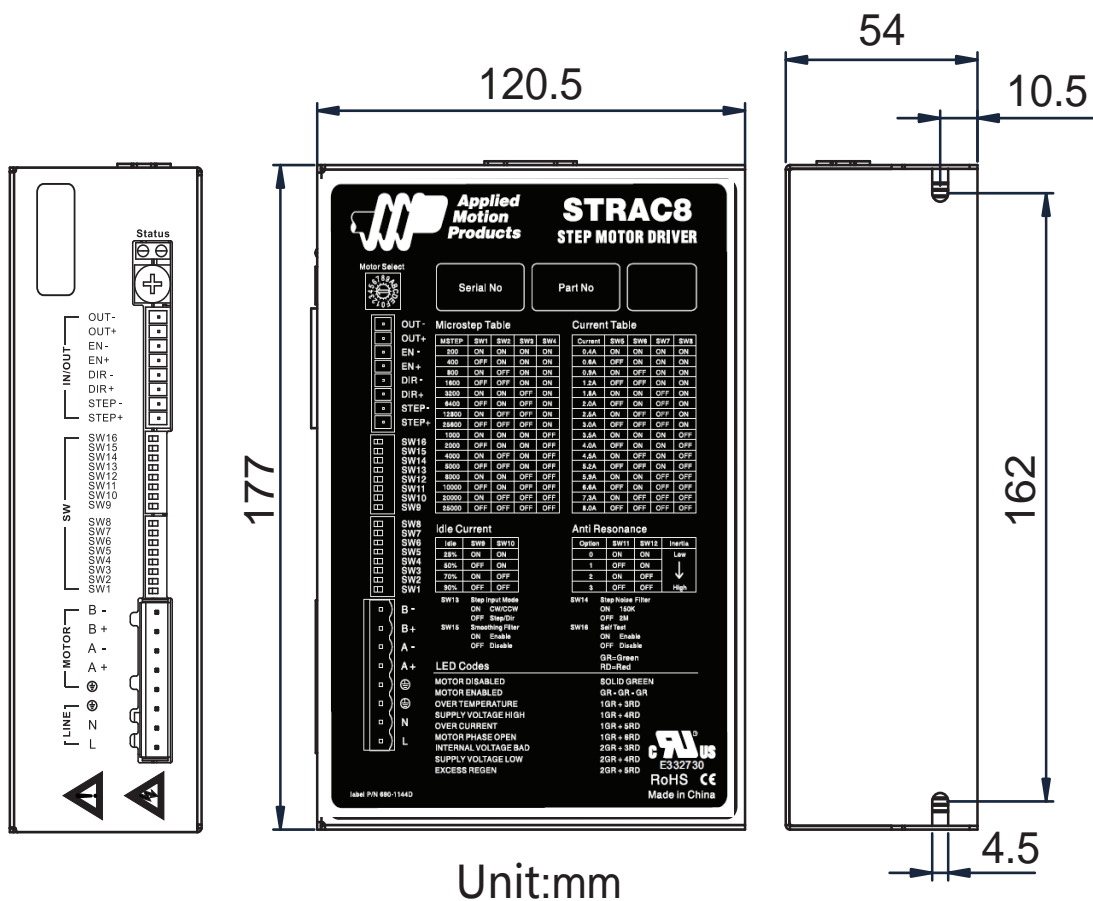

Unit:mm

7.2 Specifications

7.2.1 Electrical Specifications

Electrical Specifications					
Parameter		Min.	Typ.	Max.	Unit
Power Supply	Universal AC input	90	-	240	VAC
Output Current (Peak)		0.4	-	8.0	amps
Step Frequency		2	-	2M	Hz
STEP Minimum Pulse Width Hi and Low		250	-	-	ns
DIR Minimum Pulse Width		62.5	-	-	us
Under Voltage Protection		-	80	-	VAC
Over Voltage Protection		-	295	-	VAC
STEP/DIR Input Signal Voltage		4.0	-	28	V
OUT Maximum Output Current		-	-	100	mA
OUT Maximum Output		-	-	30	V

7.2.2 Environmental Specifications

Environmental Specifications	
Heat Sinking Method	Natural cooling or fan-forced cooling
Surrounding Air Conditions	Avoid dust, oily mist and corrosive air
Operating Temperature	0 - 40°C (32 - 104°F)
Maximum Ambient Humidity	90% non-condensing
Shock	5.9m/s ² maximum
Storage Temperature	-10 - 70°C (14 - 158°F)

8 Contacting Applied Motion Products

404 Westridge Dr.

Watsonville, CA 95076, USA

1-800-525-1609

Tel (831) 761-6555

www.applied-motion.com



ASSEMBLY TITLE: COLLAPSIBLE REWIND ASSEMBLY

DRAWING NO.: D24398-000

GENERAL FUNCTION:

- The rewind drum rolls up the liner
- The rewind arm turns in, allows the liner to be released from the rewind drum.
- The rewind flange supports and guides the liner.
- The friction clutch allows for slippage to accommodate for varying speeds between the drive roll and rewind drum.
- The adjusting knob controls the torque adjustment of the drum.

SET UP AND ADJUSTMENTS:

- Position the rewind flange slightly below the web path and lock with the set screw in the hub.
- When threading liner to the rewind, place the liner around the drum and arm, making sure that the arm is turned out.
- Tighten adjusting knob just enough to allow the rewind drum to keep up with the drive roll.

NOTE: Excessive tightening will cause the web to be wound very tight, causing difficulty in removal and possible step motor stall.

MAINTENANCE:

- Clean all parts that have acquired label or glue residue
- Replace friction disc when worn out.

TROUBLESHOOTING:

PROBLEM

- Rewind drum not rotating when stepping motor rotates
- Rewind drum not keeping up with drive roll
- Web winding too tight on hub
- Grinding in rewind hub

WHAT TO DO

- Replace timing belt from motor to rewind
- Tighten adjusting knob
- Loosen adjusting knob
- Replace friction disc by removing knob and sliding off rewind drum



ITEM	QTY	PART NO.	DESCRIPTION	PARENT ITEM
1	1	20499-001	DASHPOT & SHAFT ASSEMBLY	23100R-010RH
2	1	22189-000	COLLAPSIBLE REWIND	23100R-010RH
3	3	111075-000	BEARING, BALL	23100R-010RH
4	1	121067-000	BEARING, NEEDLE	23100R-010RH
5	2	151008-000	BEARING, THRUST WASHER	23100R-010RH
6	4	181063-000	BEARING, ROLL END	23100R-010RH
7	1	181081-000	BEARING, NEEDLE ROLLER	23100R-010RH
8	2	181082-000	BEARING, THRUST WASHER	23100R-010RH
9	1	801601-000	CHECK NUT	23100R-010RH
10	1	811216-000	EXTENSION SPRING, STAINLESS	23100R-010RH
11	2	A20931-000	IDLER ROLLER TUBE 12"	23100R-010RH
12	2	A20932-000	DANCER ROLL SHAFT 12"	23100R-010RH
13	1	A21479-000	SPRING ADJUSTMENT BLOCK	23100R-010RH
14	1	A22120-000	REWIND PULLEY ASSEMBLY	23100R-010RH
15	1	A23131-000	STUD	23100R-010RH
16	1	B20004-007	REWIND BEARING PLATE	23100R-010RH
17	1	B20005-120	GUARD	23100R-010RH
18	1	C20894-004	REWIND DANCER ARM	23100R-010RH

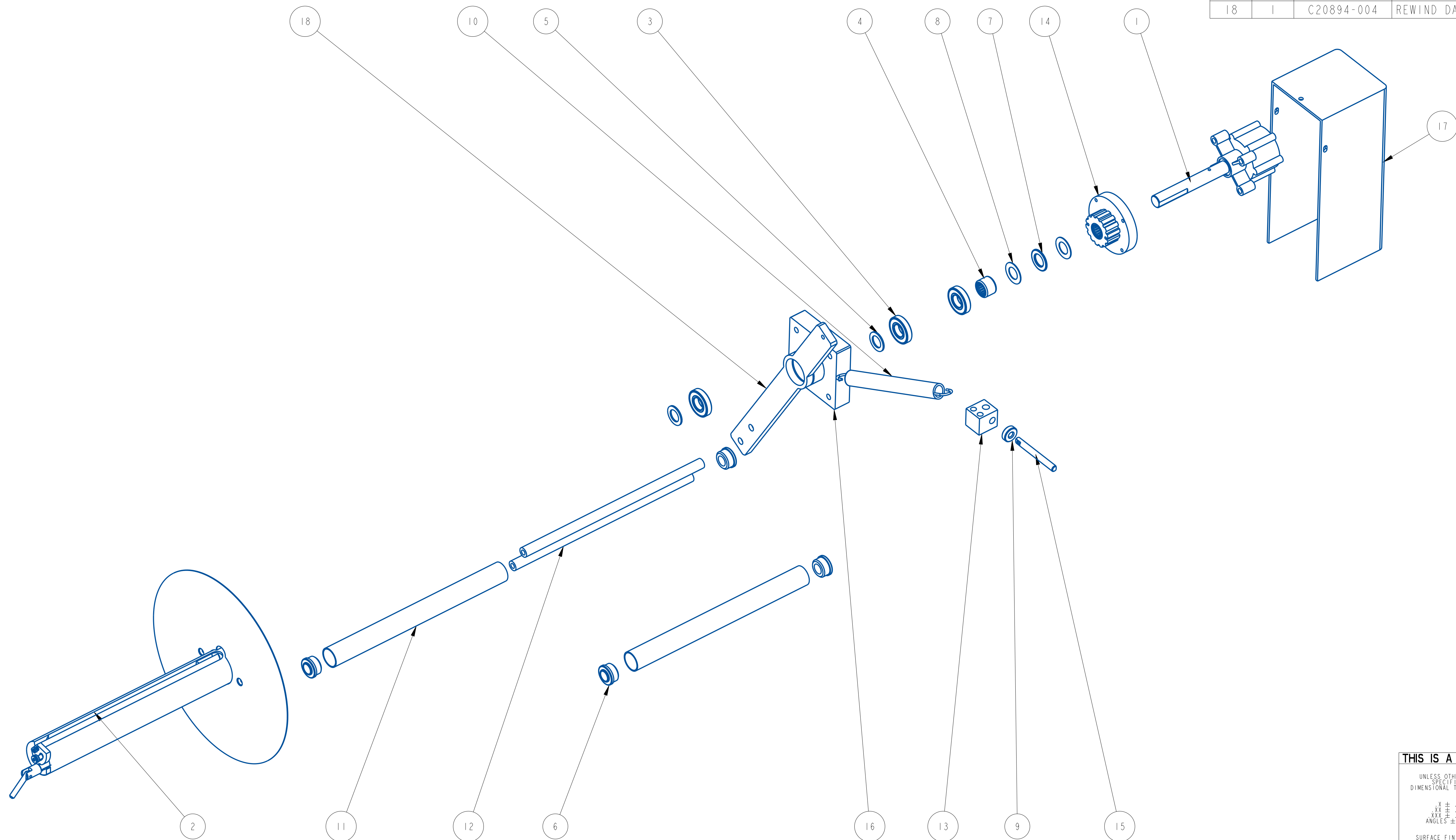

REV	DATE	DESCRIPTION	BY
A	12/03/25	NEW DRAWING	SEM

THIS IS A PRO-ENGINEER DOCUMENT AND MAY NOT BE MODIFIED MANUALLY

<small>UNLESS OTHERWISE SPECIFIED DIMENSIONAL TOLERANCE</small> X ± .1 XX ± .01 XXX ± .005 ANGLES ± 30°	QUADREL LABELING SYSTEMS		SCALE: 3/8
	7670 JENTHER DRIVE MENTOR, OHIO 44060 (440) 602-4700		DATE: Oct-02-25
			DRW BY: RDL
			CHK BY: APPR BY:
10" REWIND ASSEMBLY RHH			
SURFACE FINISH 125 BREAK ALL EDGES .005/0.15 CORNER RADIUS .010/0.30	MAT'L	23100R-010RH	23100R-010RH

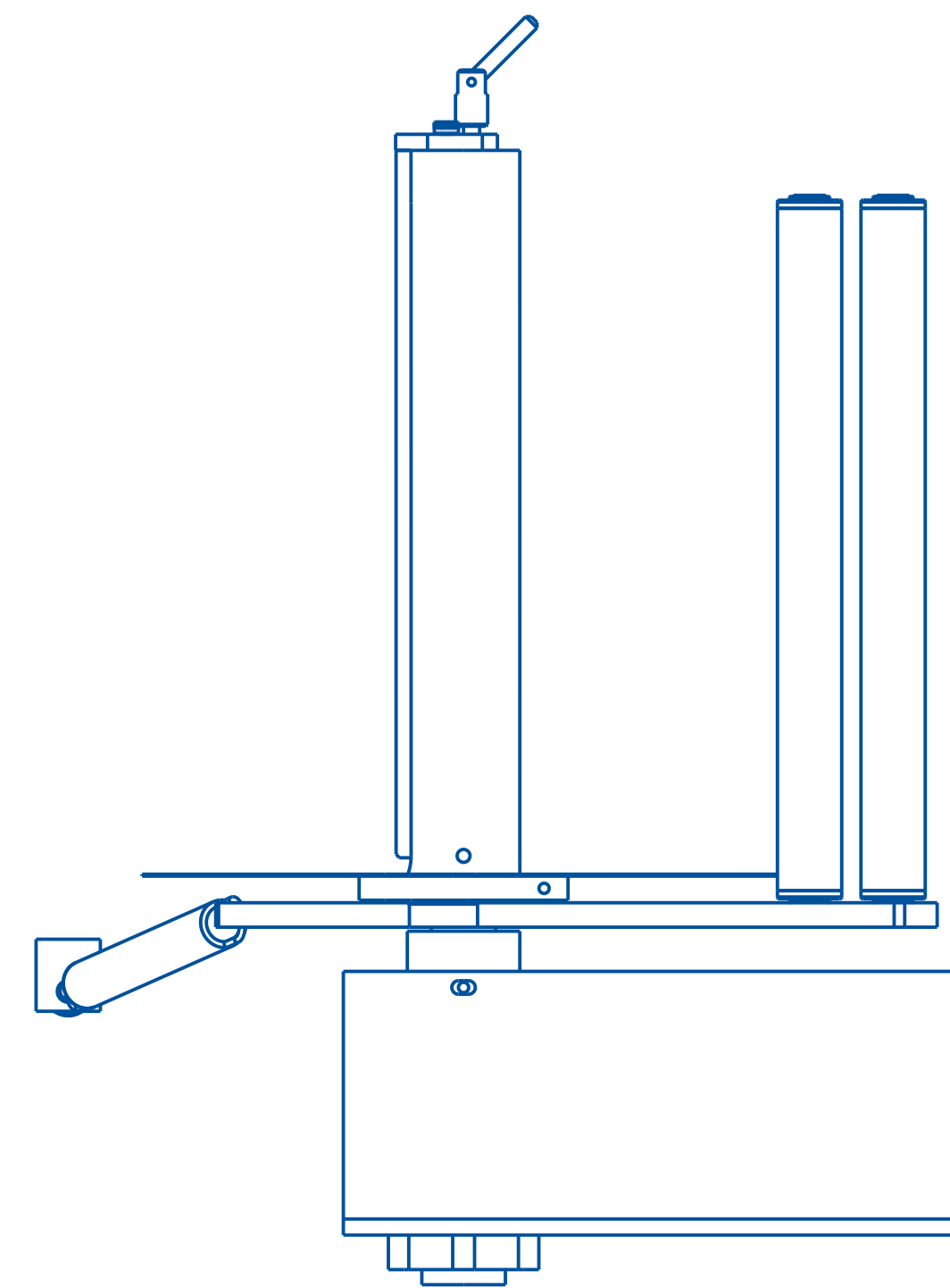
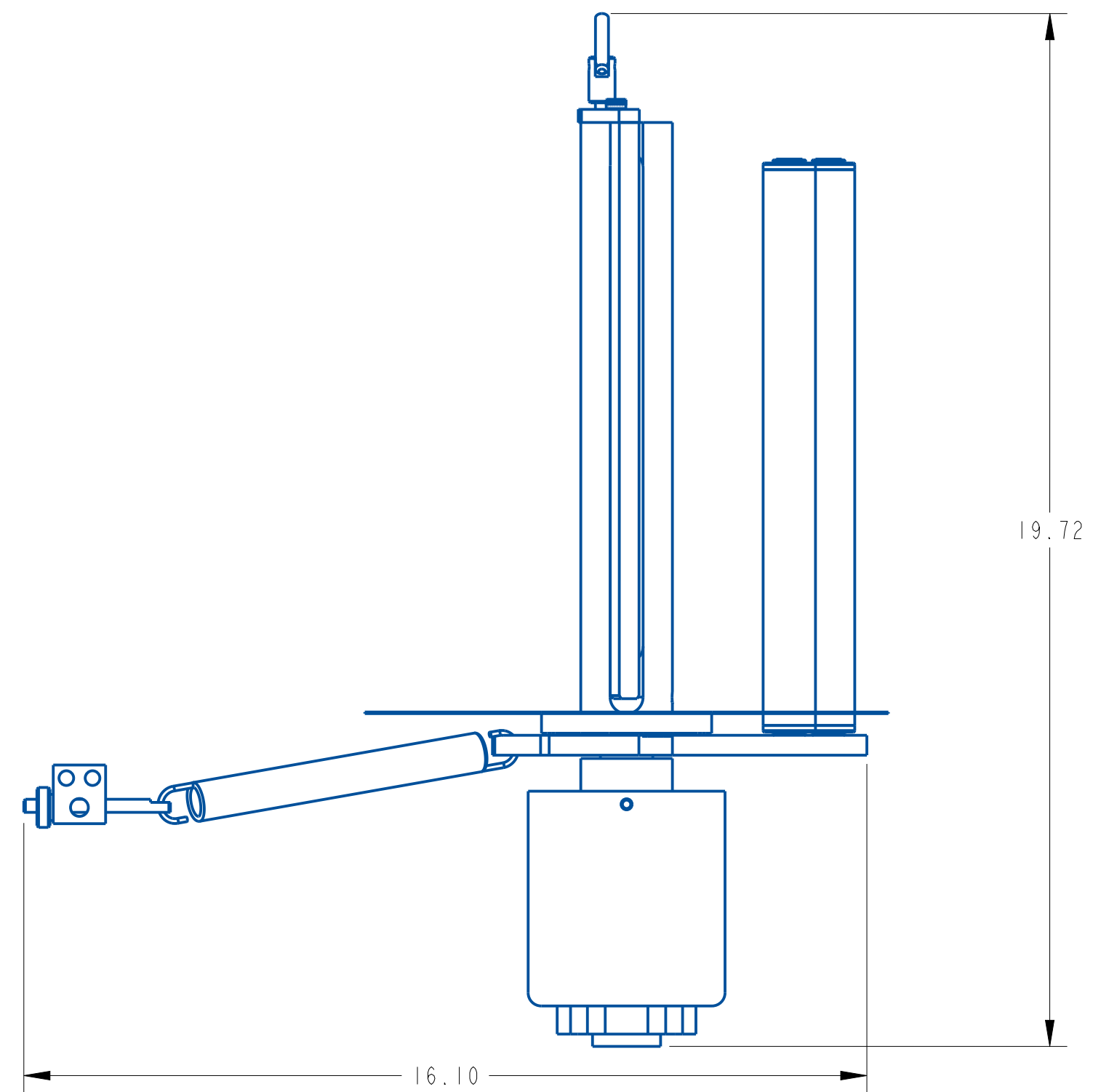
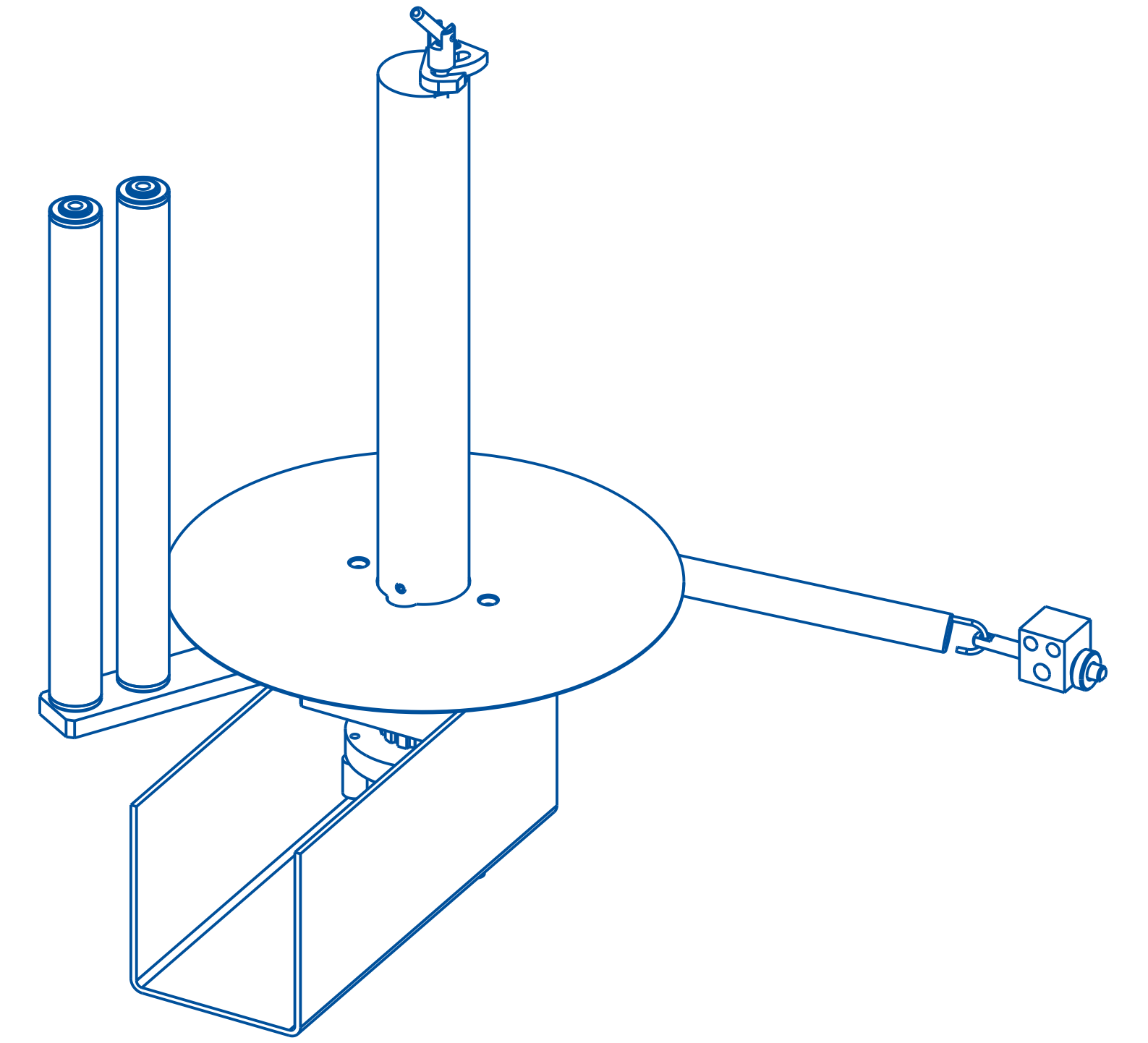
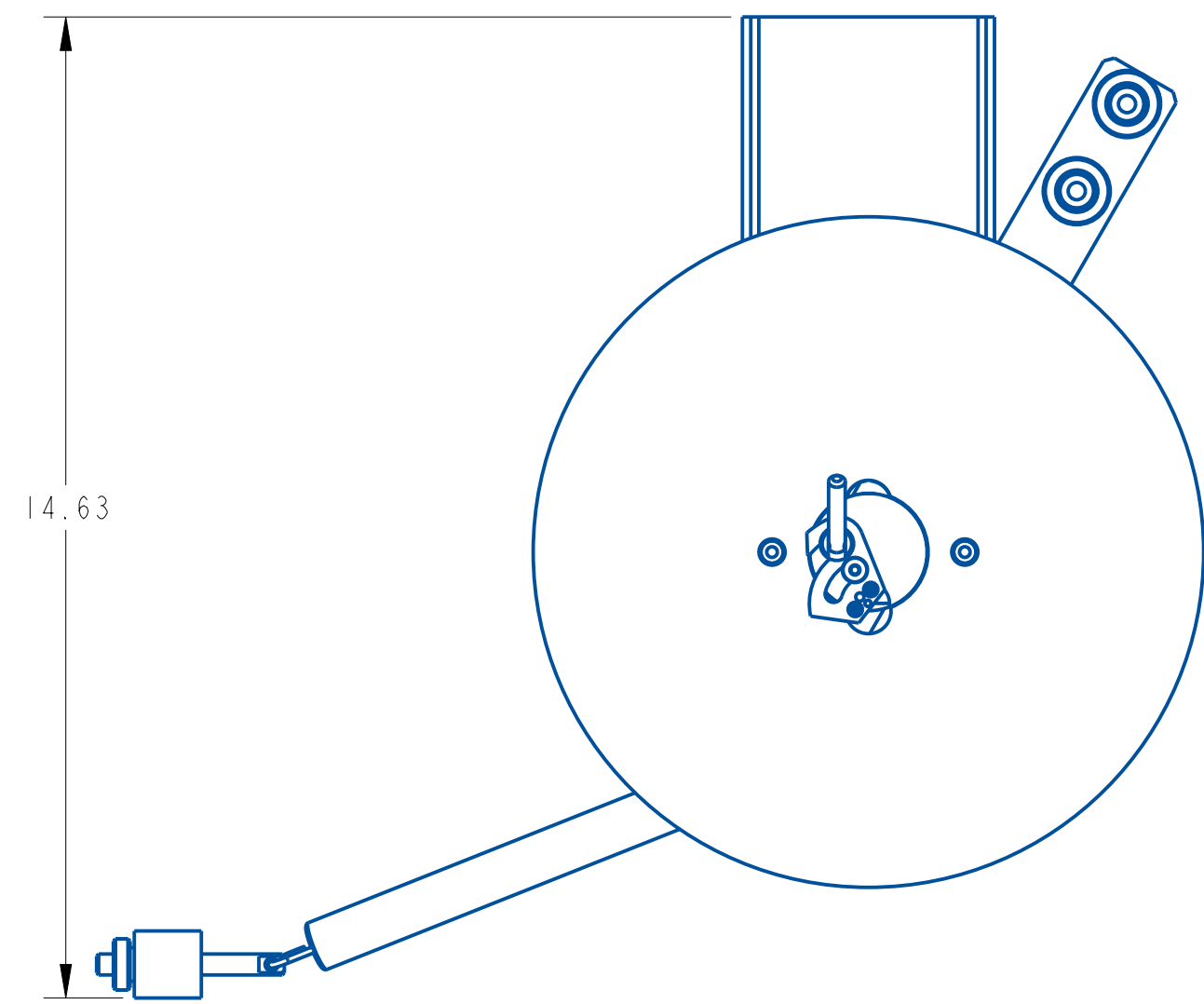

REV	DATE	DESCRIPTION	BY
A	0ct-02-25	NEW DRAWING	RDL

THIS IS A PRO-ENGINEER DOCUMENT AND MAY NOT BE MODIFIED MANUALLY

<small>UNLESS OTHERWISE SPECIFIED DIMENSIONAL TOLERANCE</small> .x ± .1 .xx ± .01 .xxx ± .005 ANGLES ± .30° SURFACE FINISH 125 BREAK ALL EDGES .005/ .015 CORNER RADIUS .010/ .030 ALL ANGLES ARE 90°	 QUADREL LABELING SYSTEMS 7670 JENTHER DRIVE MENTOR, OHIO 44060 (440) 602-4700	SCALE: 3/8
		DATE: 0ct-02-25
		DRW BY: RDL
		CHK BY:
10" REWIND ASSEMBLY RHH		APPR BY:
MAT'L	23100R-010RH	23100R-010RH

ITEM	QTY	PART NO.	DESCRIPTION	PARENT ITEM
1	1	20499-001	DASHPOT & SHAFT ASSEMBLY	23100R-010LH
2	1	22189-000	COLLAPSIBLE REWIND	23100R-010LH
3	3	111075-000	BEARING, BALL	23100R-010LH
4	1	121067-000	BEARING, NEEDLE	23100R-010LH
5	2	151008-000	BEARING, THRUST WASHER	23100R-010LH
6	4	181063-000	BEARING, ROLL END	23100R-010LH
7	1	181081-000	BEARING, NEEDLE ROLLER	23100R-010LH
8	2	181082-000	BEARING, THRUST WASHER	23100R-010LH
9	1	801601-000	CHECK NUT	23100R-010LH
10	1	811216-000	EXTENSION SPRING, STAINLESS	23100R-010LH
11	2	A20931-000	IDLER ROLLER TUBE 12"	23100R-010LH
12	2	A20932-000	DANCER ROLL SHAFT 12"	23100R-010LH
13	1	A21479-000	SPRING ADJUSTMENT BLOCK	23100R-010LH
14	1	A22120-000	REWIND PULLEY ASSEMBLY	23100R-010LH
15	1	A23131-000	STUD	23100R-010LH
16	1	B20004-007	REWIND BEARING PLATE	23100R-010LH
17	1	B20005-120	GUARD	23100R-010LH
18	1	C20894-004	REWIND DANCER ARM	23100R-010LH

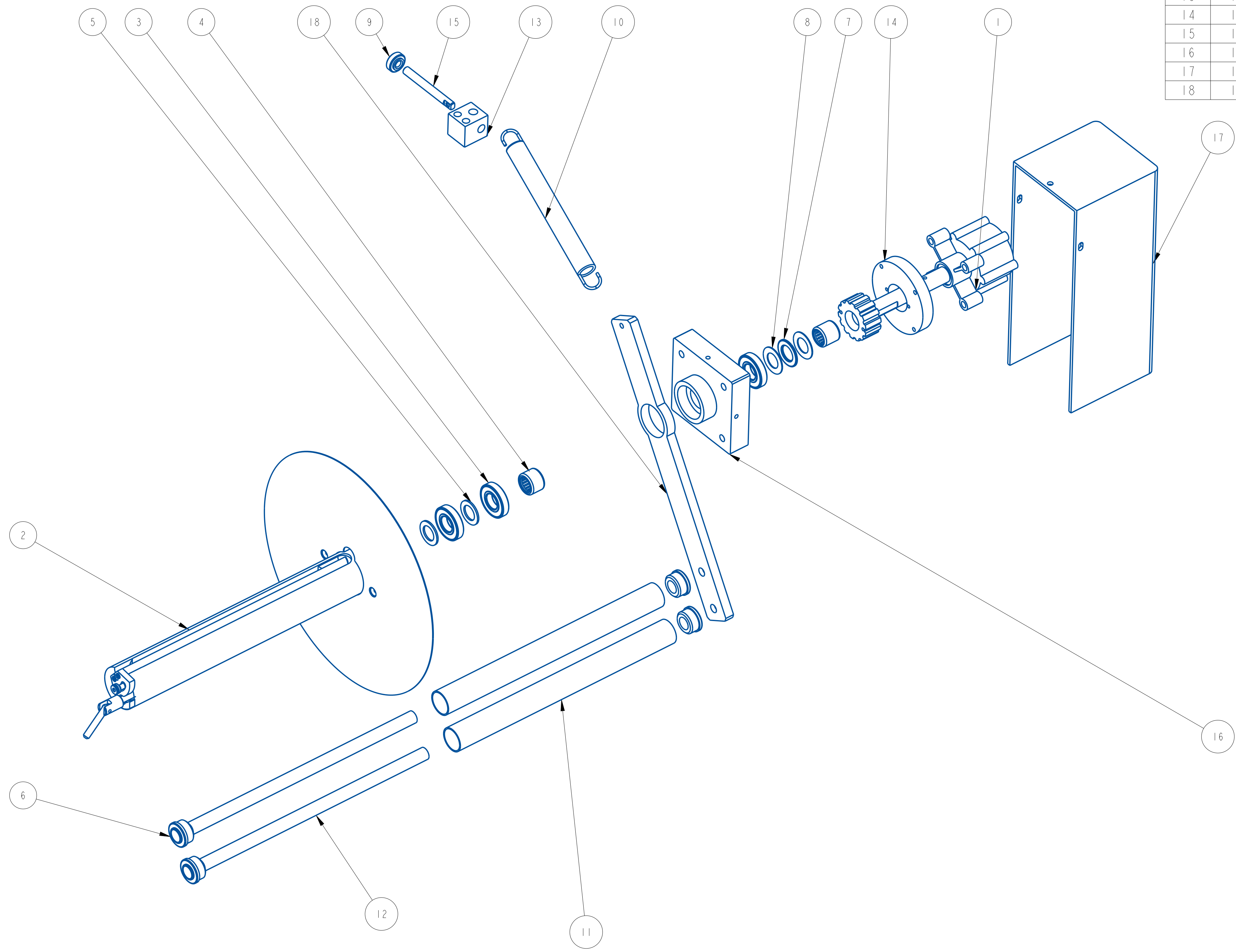

REV	DATE	DESCRIPTION	BY
A	12/03/25	NEW DRAWING	SEM

THIS IS A PRO-ENGINEER DOCUMENT AND MAY NOT BE MODIFIED MANUALLY

<small>UNLESS OTHERWISE SPECIFIED DIMENSIONAL TOLERANCE</small> x ± .1 xx ± .01 xxx ± .005 ANGLES ± .30°	QUADREL LABELING SYSTEMS		SCALE: 7/16
	7670 JENTHER DRIVE MENTOR, OHIO 44060 (440) 602-4700		DATE: Oct-06-25
			DRW BY: RDL
			CHK BY: APPR BY:
10" REWIND ASSEMBLY RHH			
SURFACE FINISH 125 BREAK ALL EDGES .005/015 CORNER RADIUS .010/030	MAT'L	23100R-010RH	23100R-010LH

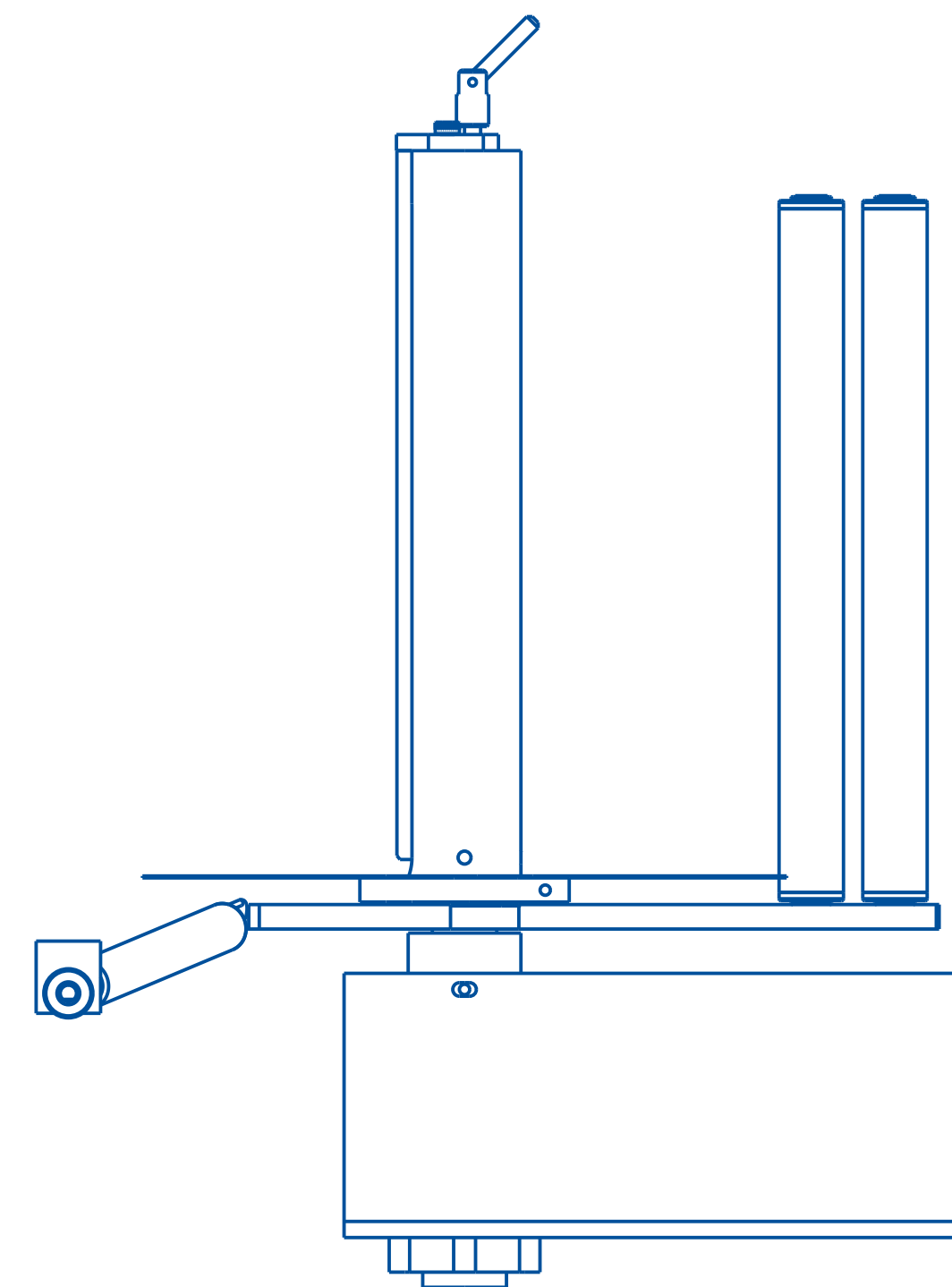
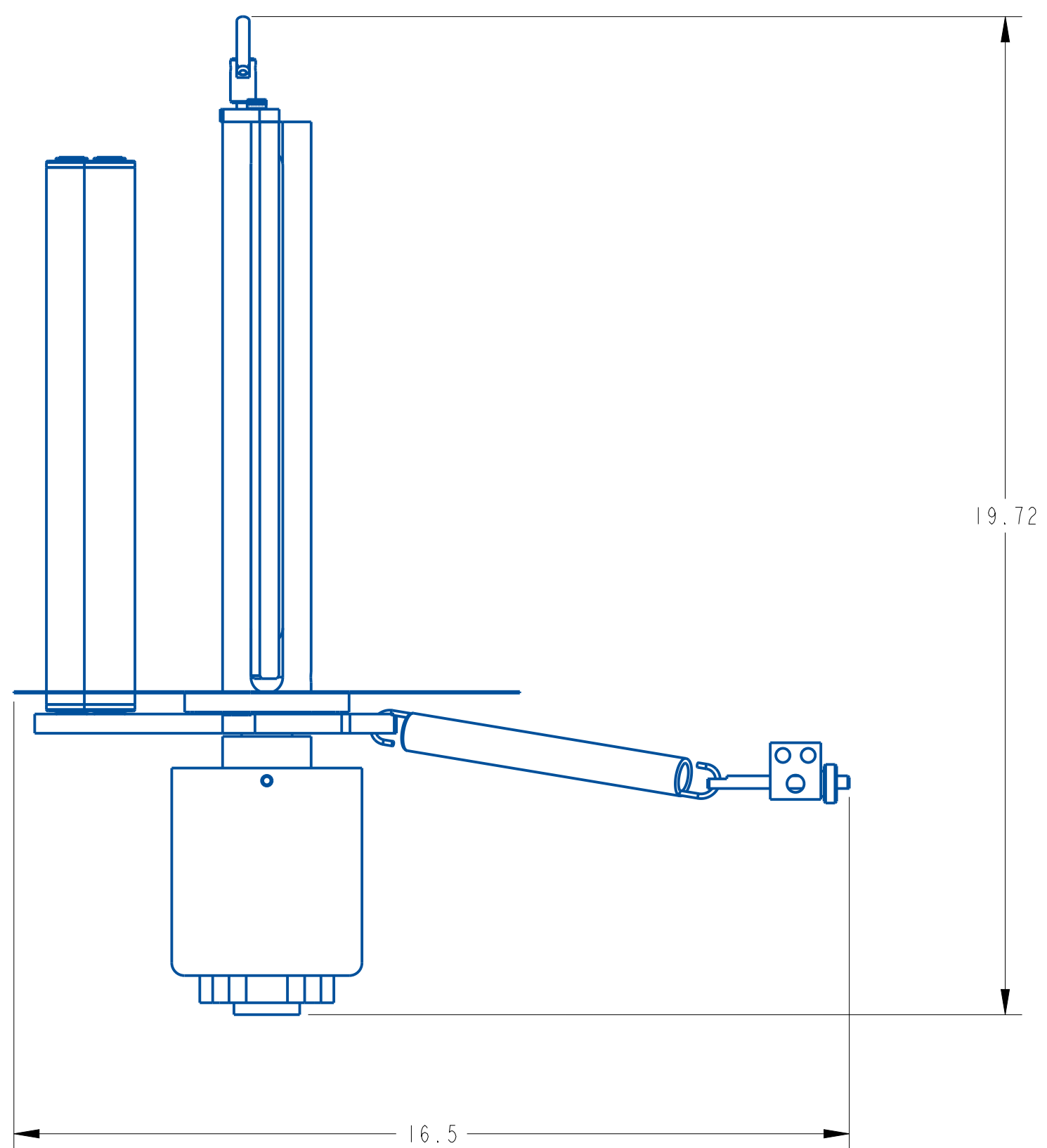
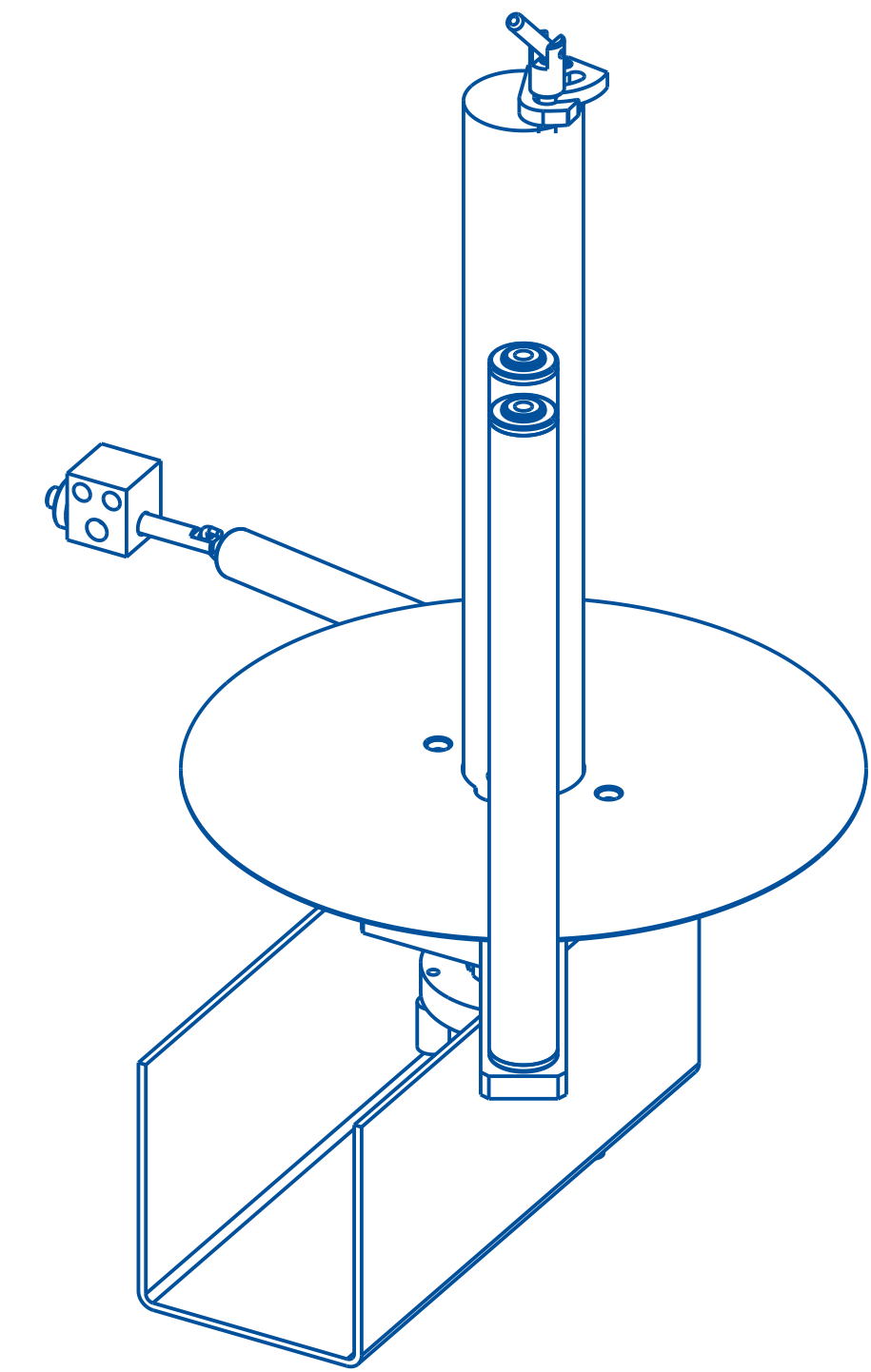
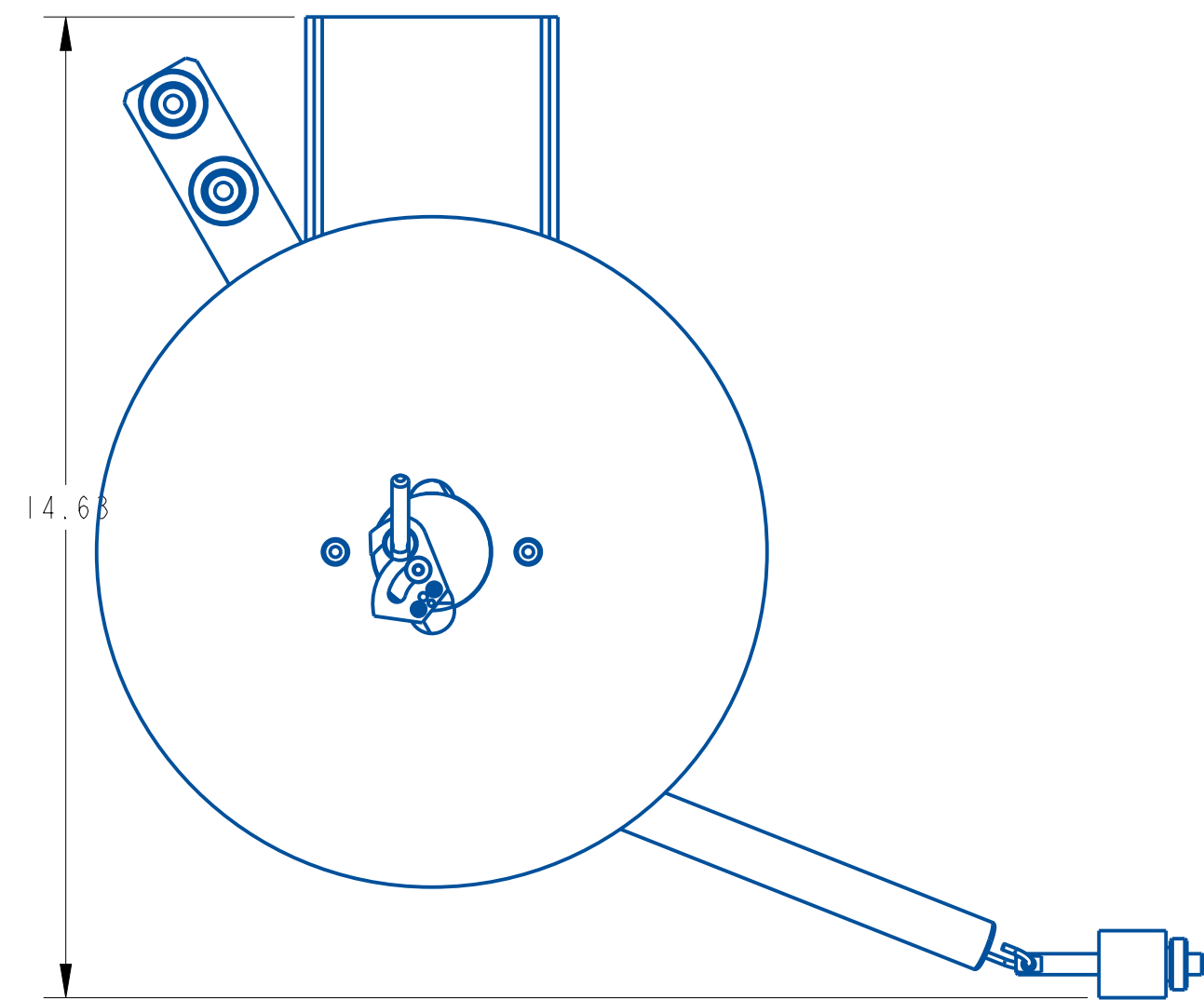

THIS IS A PRO-ENGINEER DOCUMENT AND MAY NOT BE MODIFIED MANUALLY			
REV	DATE	DESCRIPTION	BY
A	Oct-06-25	NEW DRAWING	RDL

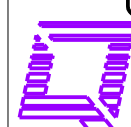
<small>UNLESS OTHERWISE SPECIFIED DIMENSIONAL TOLERANCE</small> .x ± .1 .xx ± .01 .xxx ± .005 ANGLES ± .30° SURFACE FINISH 125 BREAK ALL EDGES .005/.015 CORNER RADIUS .010/.030 ALL ANGLES ARE 90°	 QUADREL LABELING SYSTEMS 7670 JENTHER DRIVE MENTOR, OHIO 44060 (440) 602-4700	SCALE: 3/8
		DATE: Oct-06-25
		DRW BY: RDL
		CHK BY:
10" REWIND ASSEMBLY RHH		APPR BY:
MAT'L	23100R-010RH	23100R-010LH

ITEM	QTY	PART NO.	DESCRIPTION	PARENT ITEM
1	1	22597-000	COLLAPSIBLE REWIND LOCKING HANDLE	22189-000
2	1	8411145-000<CSSD>		22189-000
3	1	A21226-000	REWIND FLANGE HUB COLLAR	22189-000
4	1	A22085-001	COLLAPSIBLE REWIND REEL	22189-000
5	1	B22103-002	10" COLLAPSIBLE REWIND DRUM	22189-000
6	1	B22141-002	SHAFT ASSEMBLY	22189-000
7	1	SYE103		22189-000

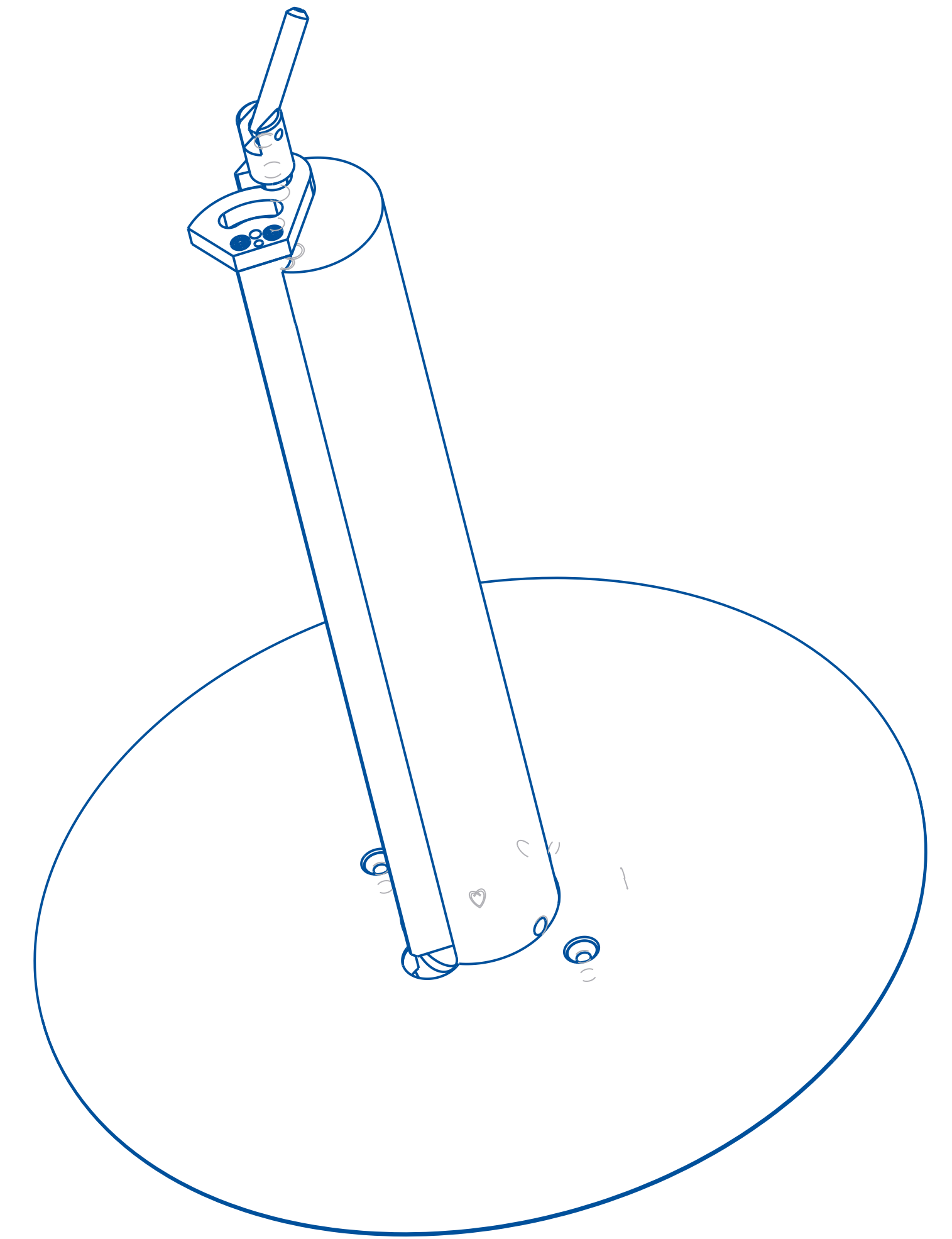
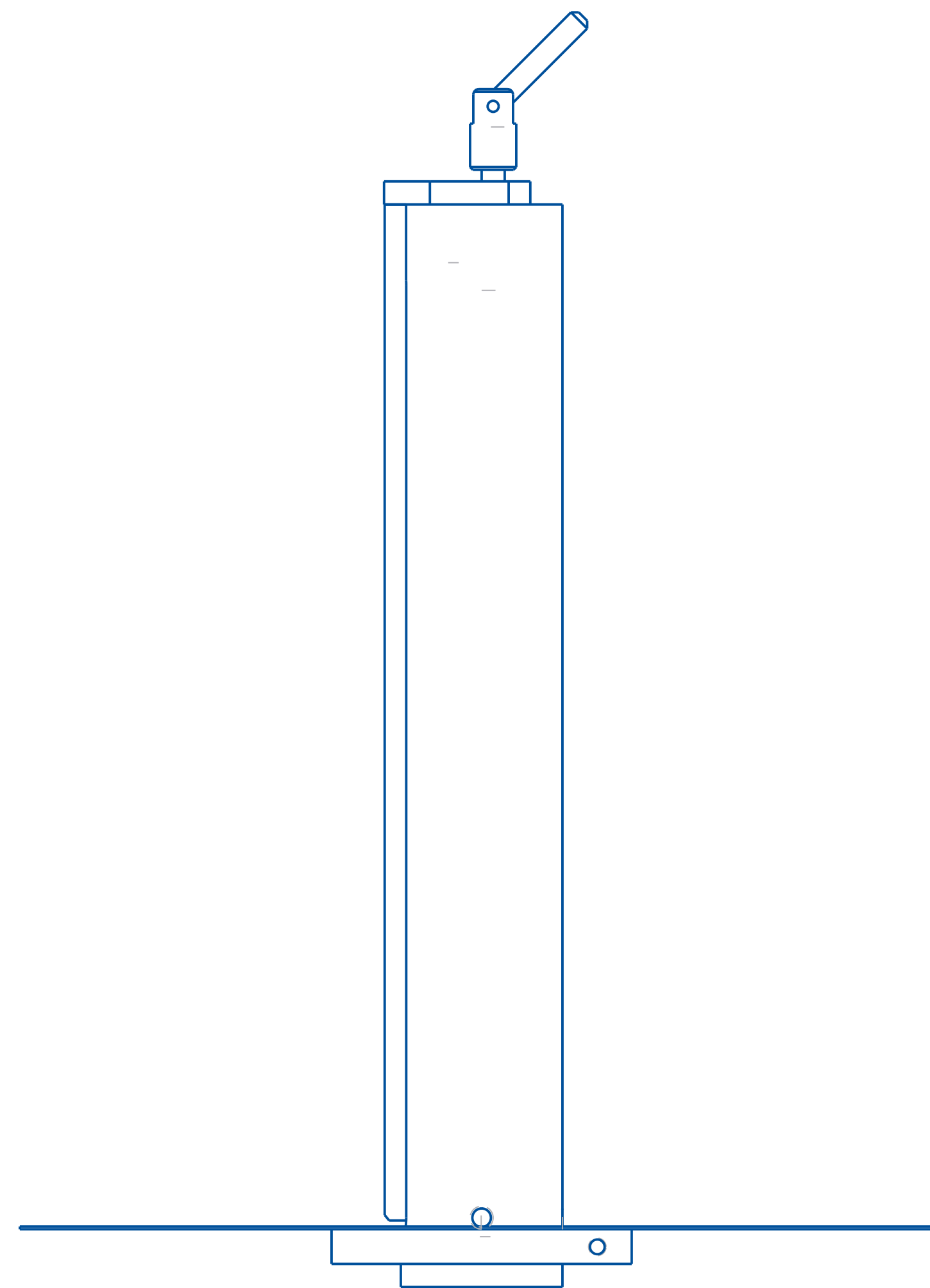
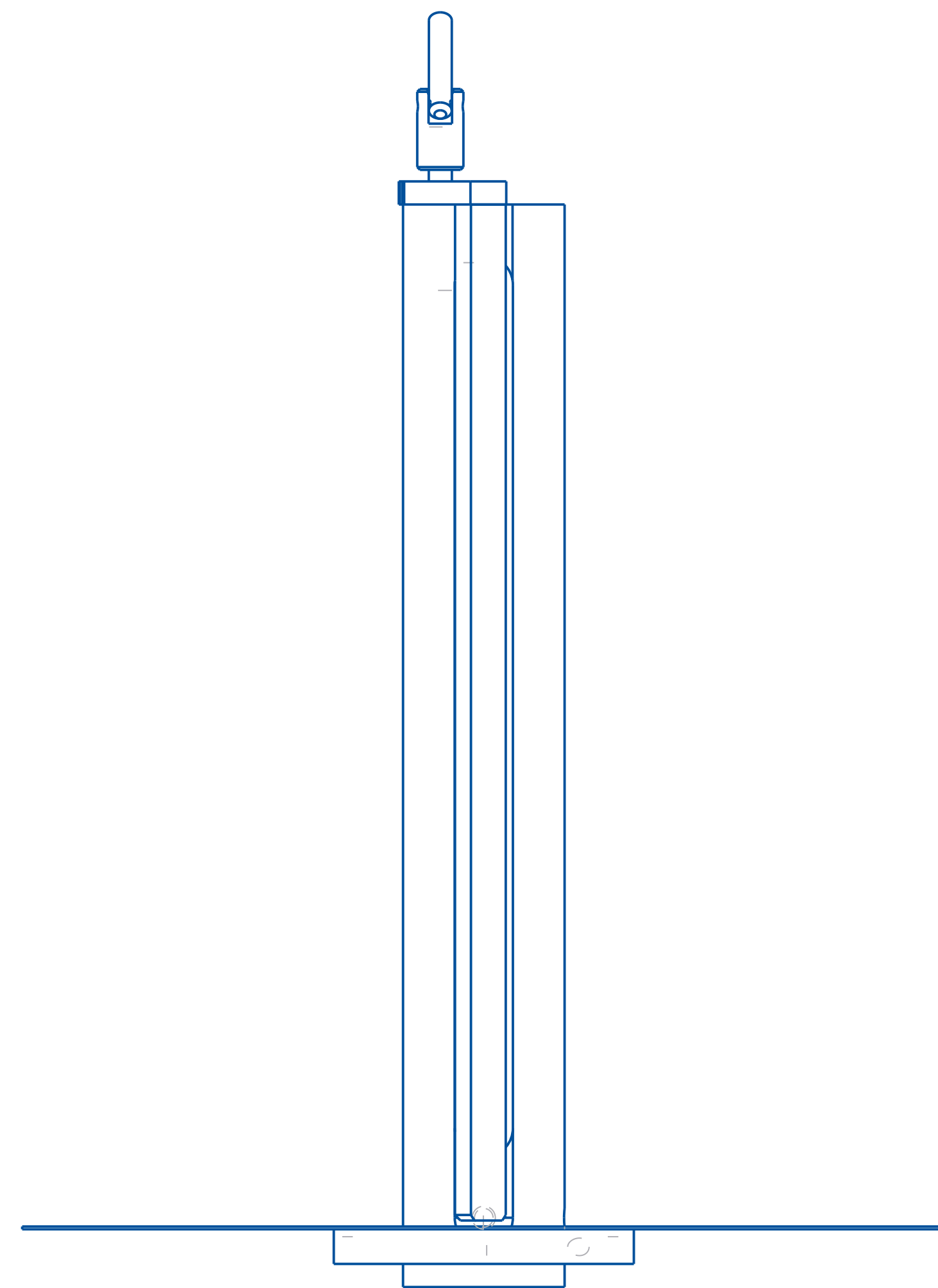

REV	DATE	DESCRIPTION	BY
A	06/09/2008	NEW DRAWING	SEM

THIS IS A PRO-ENGINEER DOCUMENT AND MAY NOT BE MODIFIED MANUALLY

UNLESS OTHERWISE SPECIFIED DIMENSIONAL TOLERANCE	 QUADREL LABELING SYSTEMS 7670 JENTHER DRIVE MENTOR, OHIO 44060 (440) 602-4700	SCALE: 3/4 DATE: 06/09/2008 DRW BY: SEM CHK BY: APPR BY:
.1 .01 .005 ANGLES ± 30°	COLLAPSIBLE REWIND	
SURFACE FINISH 125 BREAK ALL EDGES .005/.015 CORNER RADIUS .010/.030	MAT'L 22189-000	D22393-000

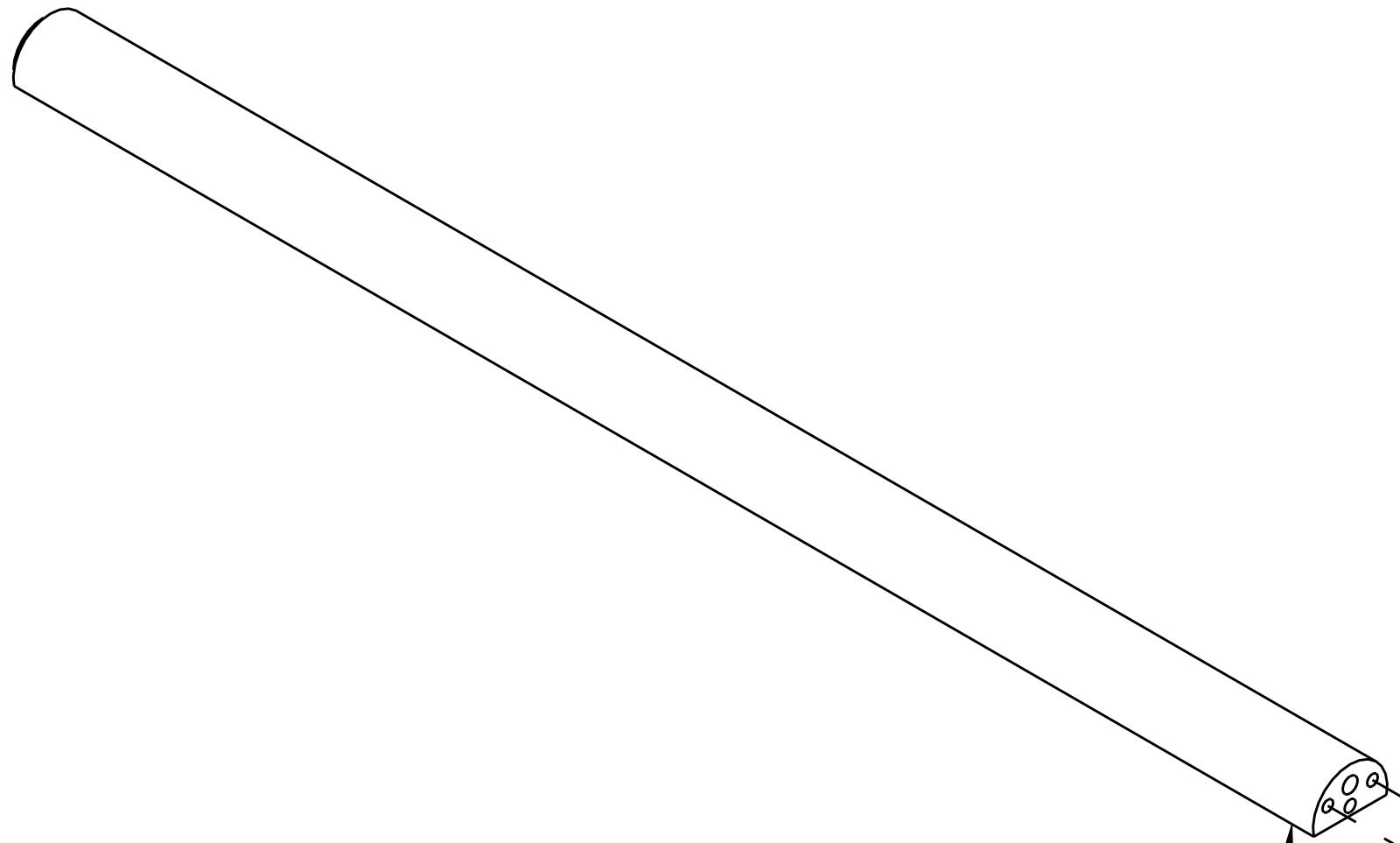

ITEM	QTY	PART NO.	DESCRIPTION
1	1	871352-000	DOWELL, PIN 1/8" x 1/2" SS.
2	1	871371-000	DOWELL, PIN 3/32" x 1/2" SS.
3	1	A22081-001	COLLAPSIBLE REWIND CAM
4	1	A25272-002	COLLAPSIBLE REWIND SHAFT
5	2	SHCS	4-40 X 1/2 LG. SHCS

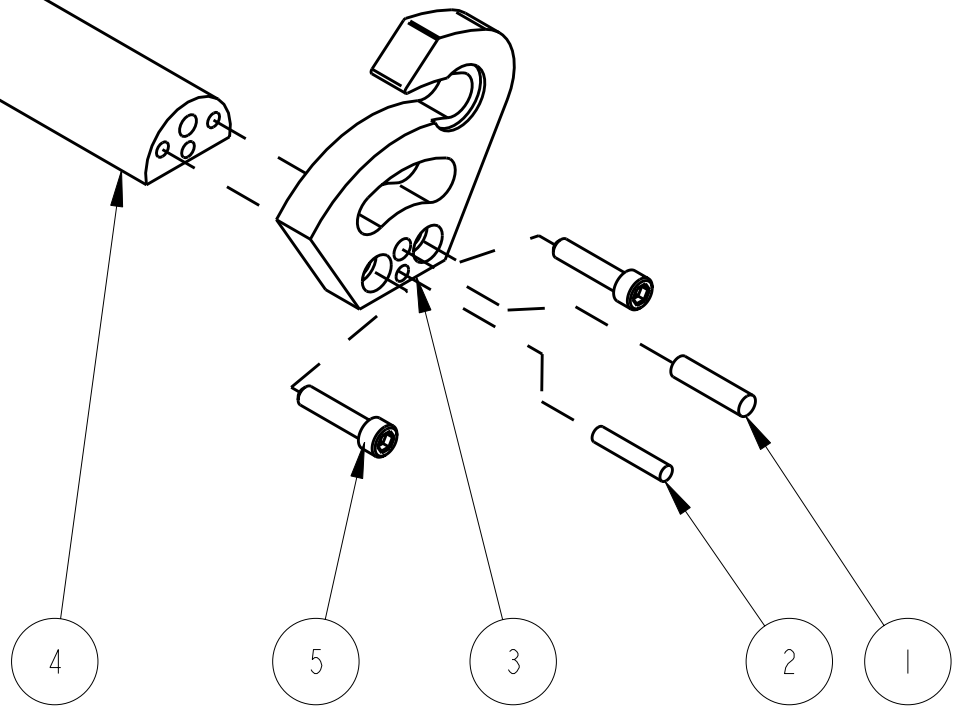

REV	DATE	DESCRIPTION
A	06/09/2008	NEW DRAWING

THIS IS A PRO-ENGINEER DOCUMENT AND MAY NOT BE MODIFIED MANUALLY

UNLESS OTHERWISE SPECIFIED
DIMENSIONAL TOLERANCE

.X ± .1
.XX ± .01
.XXX ± .005
ANGLES ± 30°

SURFACE FINISH 125
BREAK ALL EDGES .005/.015
CORNER RADIUS .010/.030

QUADREL LABELING SYSTEMS
7670 JENTHER DRIVE
MENTOR, OHIO 44060
(216) 975-0006

SCALE: 1/1
DATE: 06/09/2008
DRW BY: SEM
CHK BY:
APPR BY:

SHAFT ASSEMBLY 10.0"

MAT'L

B22141-002

ITEM	QTY	PART NO.	DESCRIPTION
1	1	871352-000	DOWELL,PIN 1/8" x 1/2" SS.
2	1	A26128-000	CLEVIS
3	1	A26129-000	HANDLE
4	1	SYE601	1/4-20 X 1-1/4 LG. SET SCREW

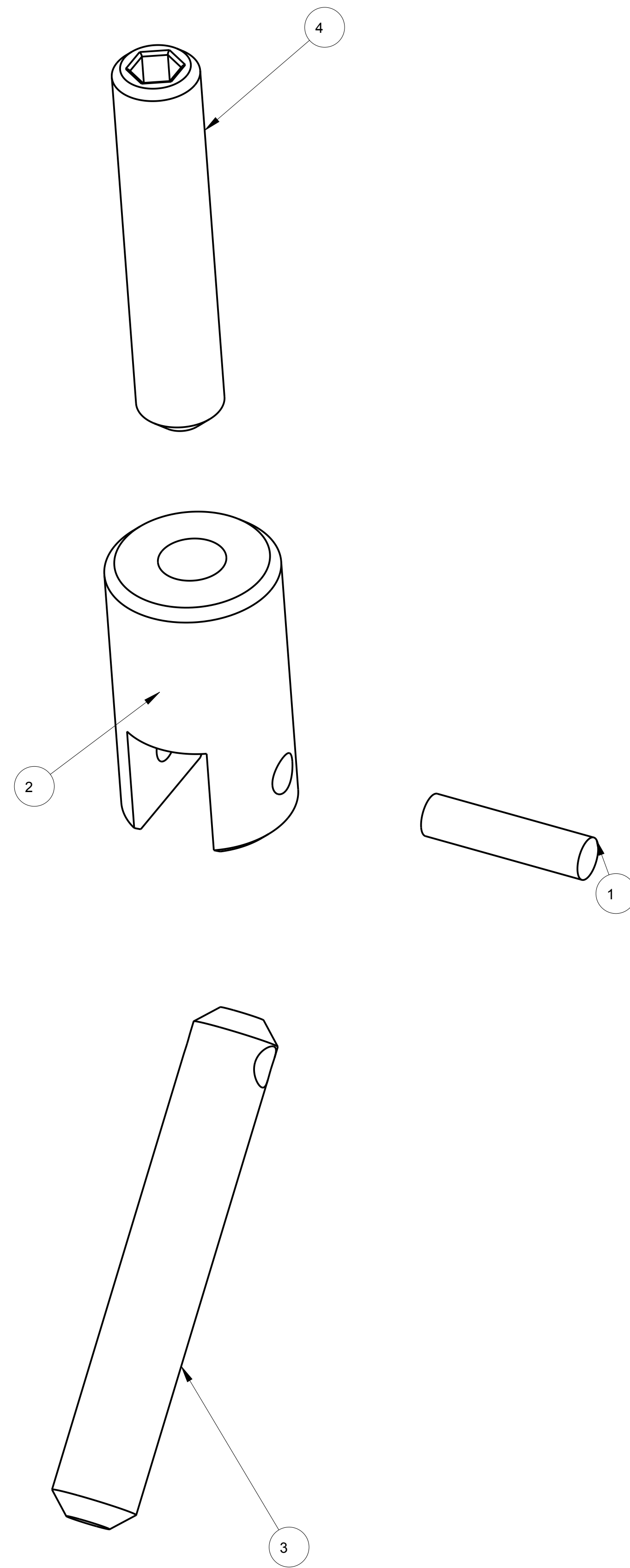

REV	DATE	DESCRIPTION	BY
A	12-11-14	NEW DRAWING	

THIS IS A PRO-ENGINEER DOCUMENT AND MAY NOT BE MODIFIED MANUALLY

UNLESS OTHERWISE SPECIFIED DIMENSIONAL TOLERANCE .X± .1 .XX± .01 .XXX± .005 ANGLES ± .30°	QUADREL LABELING SYSTEMS 7670 JENTHER DRIVE MENTOR, OHIO 44060 (440) 602-4700		SCALE 4/1 DATE 12-11-14 DRAWN BY ATT
	COLLAPSIBLE REWIND LOCKING HANDLE		
	SURFACE FINISH 125 BREAK ALL EDGES .005/.015 CORNER RADIUS .010/.030	MAT'L 22597-000	22597-000

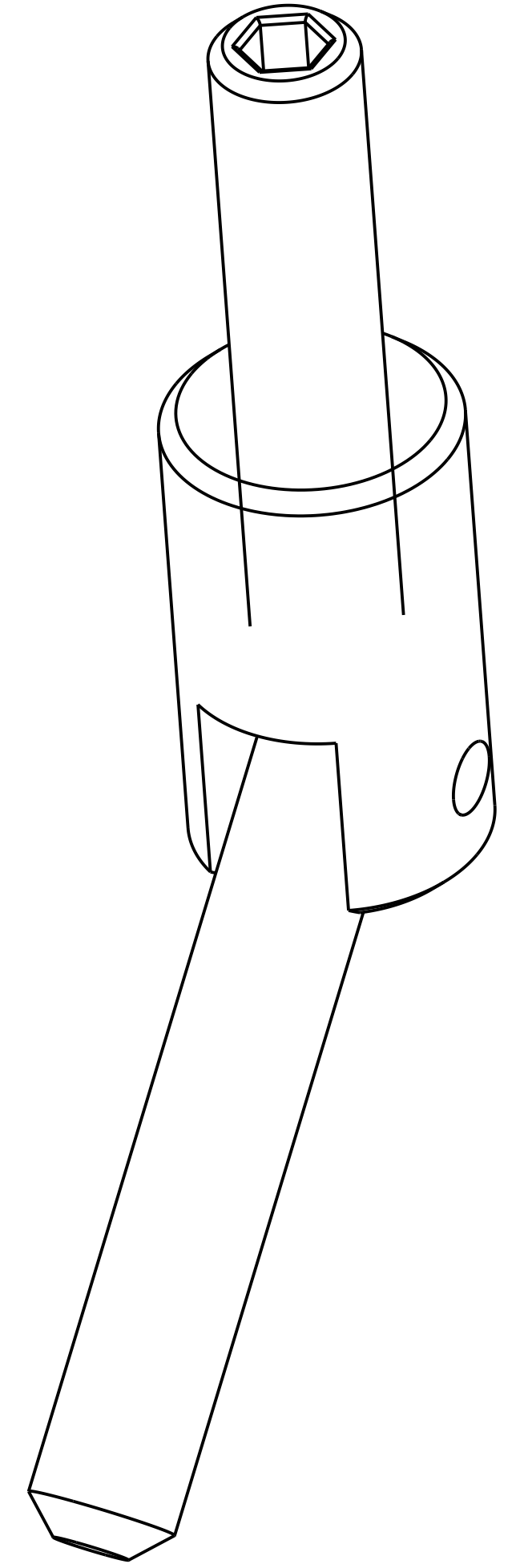
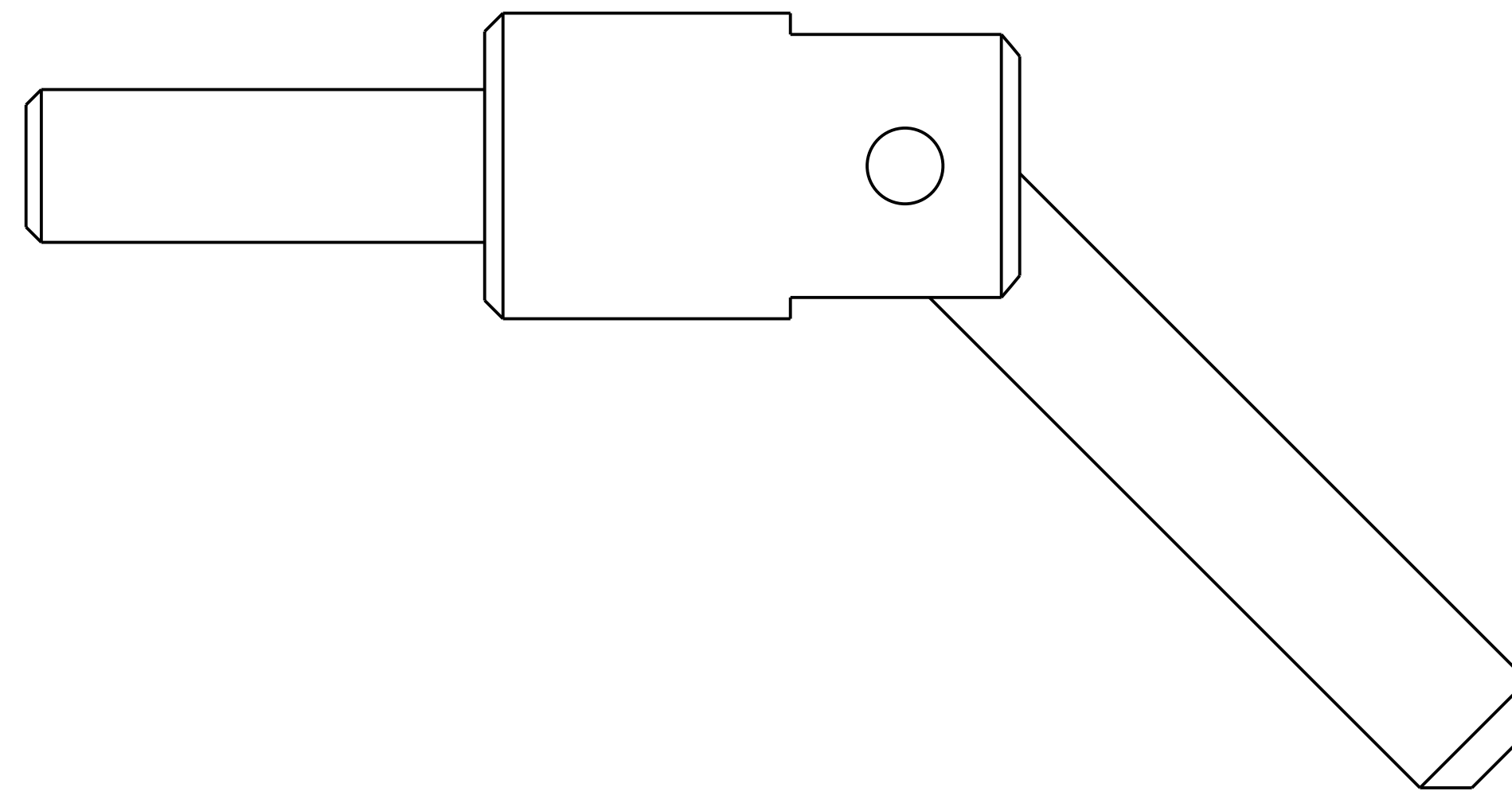
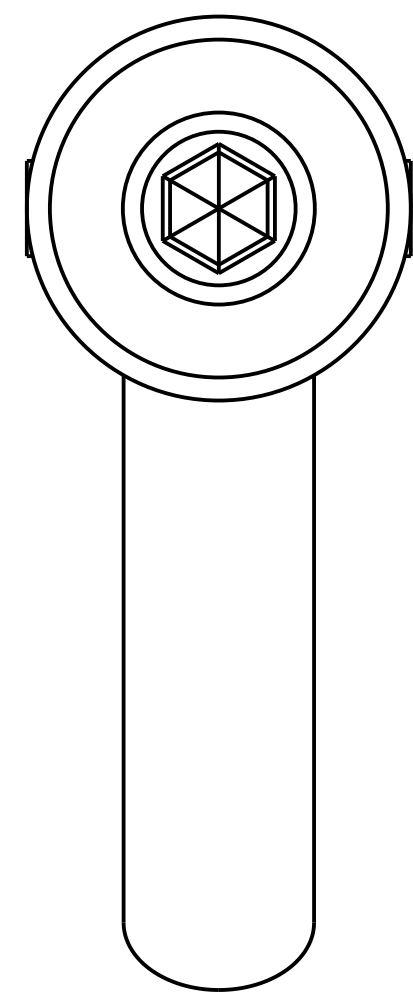
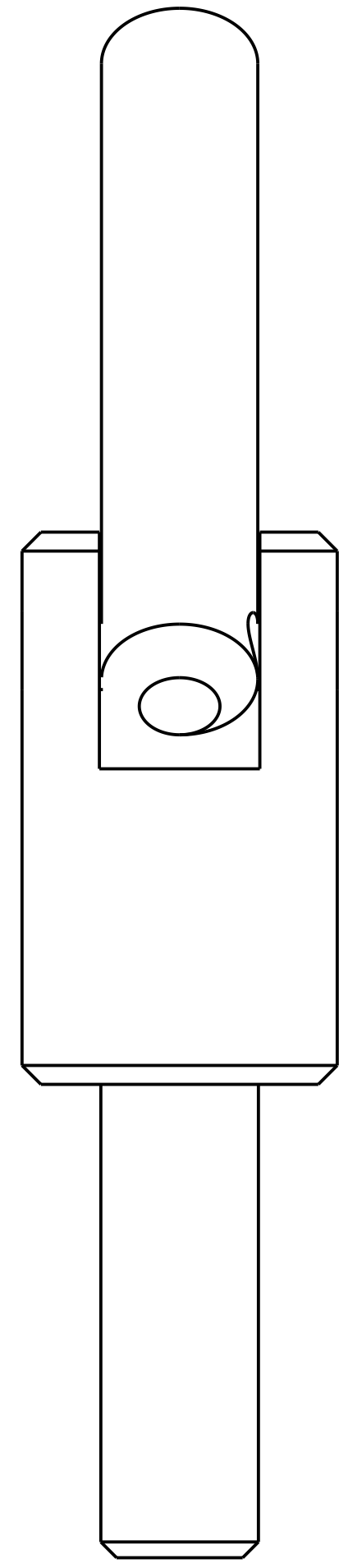

UNLESS OTHERWISE SPECIFIED DIMENSIONAL TOLERANCE		X± .1 XX± .01 XXX± .005 ANGLES ± .30°	
SURFACE FINISH 125 BREAK ALL EDGES .005/015 CORNER RADIUS .010/030		MAT'L 22597-000	

THIS IS A PRO-ENGINEER DOCUMENT AND MAY NOT BE MODIFIED MANUALLY			
REV	DATE	DESCRIPTION	BY
A	12-11-14	NEW DRAWING	
QUADREL LABELING SYSTEMS 7670 JENTHER DRIVE MENTOR, OHIO 44060 (440) 602-4700		SCALE	4/1
		DATE	12-11-14
		DRAWN BY	ATT
COLLAPSIBLE REWIND LOCKING HANDLE			
			22597-000

ASSEMBLY TITLE: SLOT SENSOR ASSEMBLY

GENERAL FUNCTION:

- The slot sensor detects the separation between labels. This signals the electronics to stop the drive motor.
- The two (2) liner support rods prevent the liner from wearing out the slot sensor.
- The knob and thumbscrew lock the sensor firmly on the mounting rods.
- The male connector provides quick connection to the labeling head.

SET UP AND ADJUSTMENTS:

- See attached cut sheet

MAINTENANCE:

- Keep the sensor optical area clean from label and glue residue

TROUBLESHOOTING:

<u>PROBLEM</u>	<u>WHAT TO DO</u>
- No power to the sensor	- Check male connector and tightly secure connection to the head.
- Liner dragging over the slot	- Loosen knob and rotate slot sensor slot sensor surface liner rests on both support rods
- Too much slack through slot sensor	- Adjust brake brush tension
- Slot sensor moving with web	- Tighten all three (3) adjusting knobs

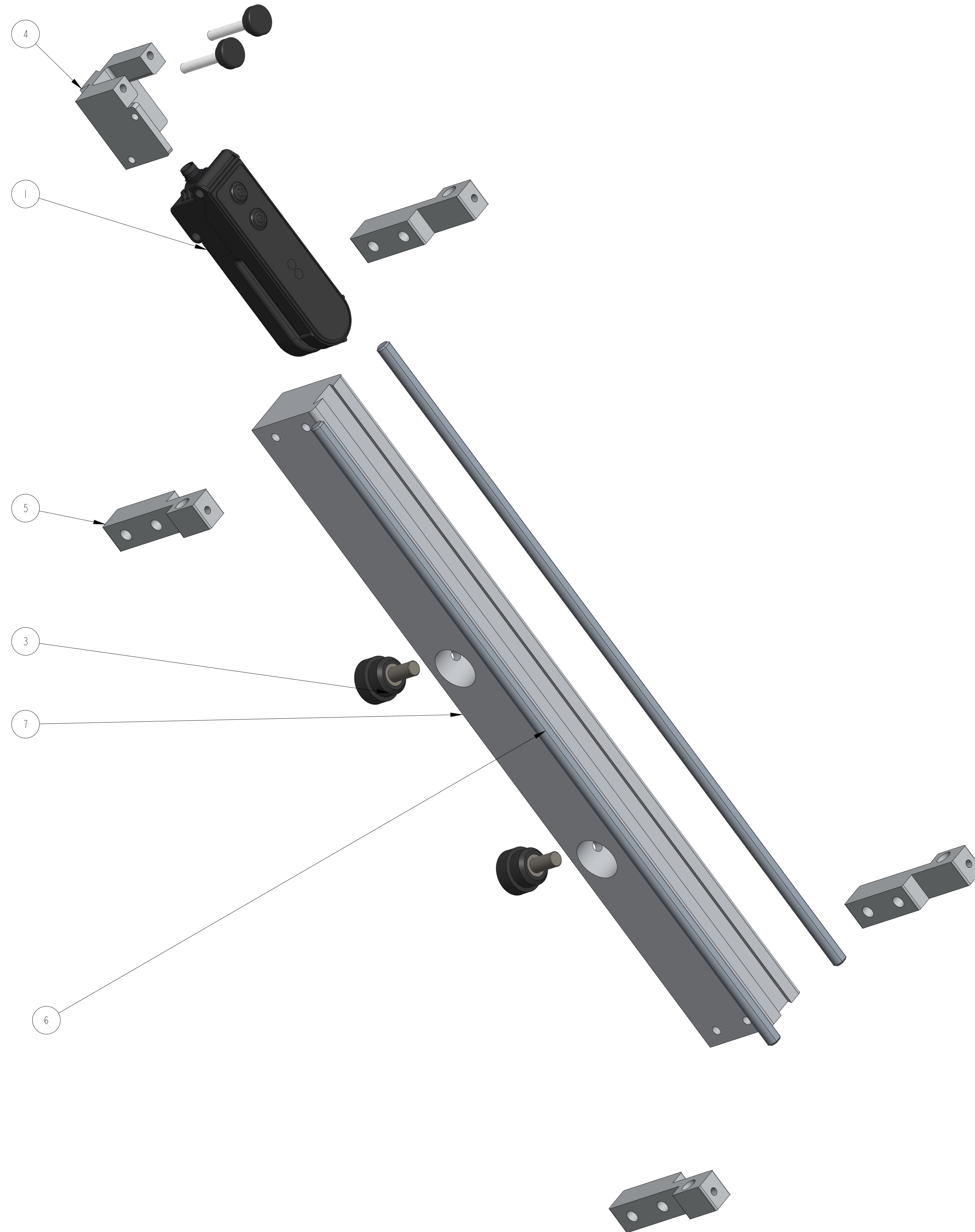

ITEM	QTY	PART NO.	DESCRIPTION	PARENT ITEM
1	1	201444-300	TRITRONICS MODEL LERC	20033-310
2	2	801297-000	THUMB SCREW PLSTC HEAD 8-32x1	20033-310
3	2	801299-000	KNOB WITH STUD	20033-310
4	1	A21391-301	SLOT SENSOR ADAPTER	20033-310
5	4	A21749-300	SLOT SENSOR SUPPORT ROD MTG BLOCK	20033-310
6	2	A21770-310	SUPPORT ROD WITH FLAT	20033-310
7	1	B20852-310	10 IN. WEB SLOT SENSOR MTG. BAR	20033-310

REV	DATE	DESCRIPTION	BY
A	Mar-05-21	NEW DRAWING	TAZ

THIS IS A PRO-ENGINEER DOCUMENT AND MAY NOT BE MODIFIED MANUALLY

UNLESS OTHERWISE SPECIFIED DIMENSIONAL TOLERANCE X ± .1 XX ± .01 XXX ± .005 ANGLES ± 30°	QUADREL LABELING SYSTEMS 7670 JENTHER DRIVE MENTOR, OHIO 44060 (440) 602-4700		SCALE: 1/1 DATE: Mar-05-21 DRW BY: TAZ CHK BY: 04/18/2024-SEM APPR BY:
	LABEL DETECT ASSEMBLY		
	SURFACE FINISH 125 BREAK ALL EDGES .005/0.15 CORNER RADIUS .010/0.30		MAT'L 20033-310
	QUADREL LABELING SYSTEMS		

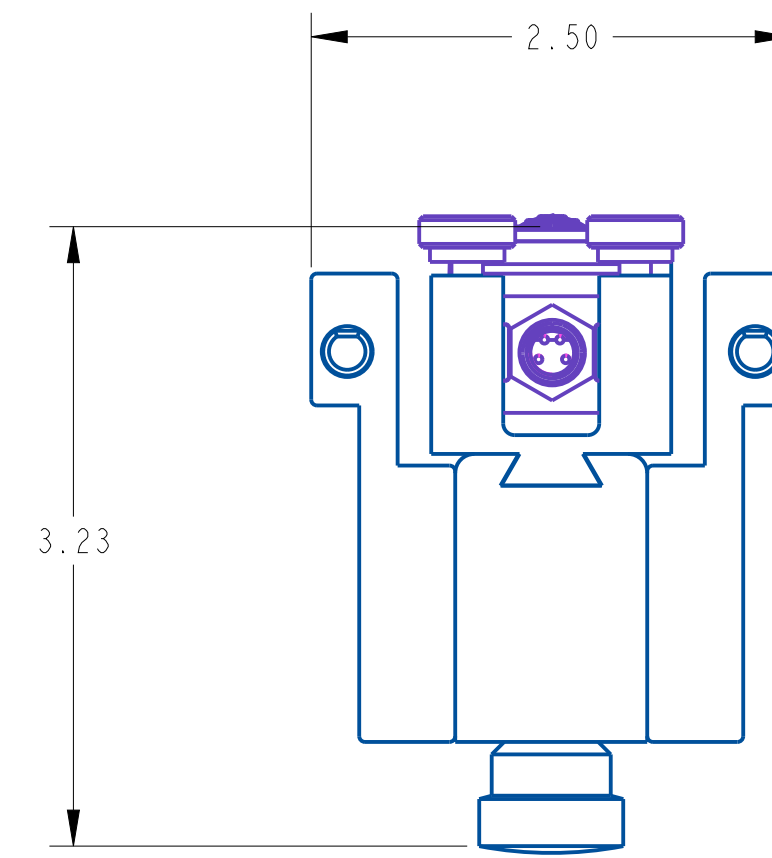
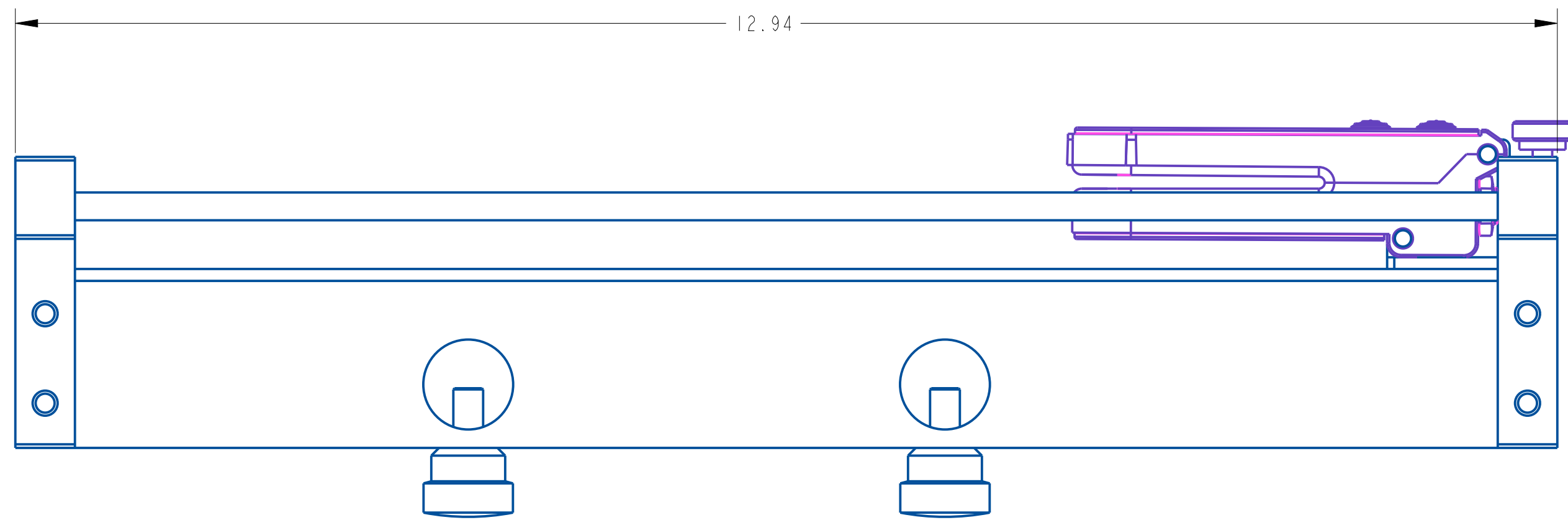

UNLESS OTHERWISE SPECIFIED		SCALE: 1/1	
DIMENSIONAL TOLERANCE		DATE: Mar-05-21	
x ± .1	xx ± .01	DRW BY: TAZ	
xxx ± .005	ANGLES ± .30°	CHK BY: 04/18/2024-SEM	
SURFACE FINISH: 125		APPR BY:	
BREAK ALL EDGES .005/ .015		MATERIAL	
CORNER RADIUS .010/ .030		20033-310	
ALL ANGLES ARE 90°			

A	Mar-05-21	NEW DRAWING	TAZ
REV	DATE	DESCRIPTION	BY

THIS IS A PRO-ENGINEER DOCUMENT AND MAY NOT BE MODIFIED MANUALLY

QUADREL LABELING SYSTEMS
 7670 JENTHER DRIVE
 MENTOR, OHIO 44060
 (440) 602-4700

LABEL DETECT ASSEMBLY

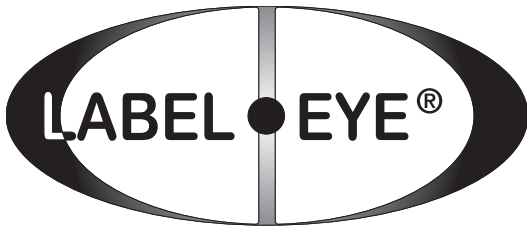

LABEL•EYE Set-Up Instructions

Standard LABEL•EYE

Normal Label Opacity AUTOSET Button

This category includes most paper or metallized film labels adhering to paper or transparent backing materials. To implement the one button AUTOSET routine, utilize the external alignment guides to position the gap between labels in line with the dot shown in the center of the detection zone. Then push the AUTOSET button marked "Normal."

An alternative set up procedure would be to remove a label and the push the "Normal" AUTOSET button.

On rare occasions, when the light is unable to penetrate the backing materials, both the red and green led indicators will blink four times. When this indication occurs, the sensor will be unable to detect the presence of the labels.

Translucent Label Opacity AUTOSET Button

This category includes translucent labels adhering to transparent or paper backing materials. To implement the one button AUTOSET routine, utilize the external alignment guides to position the gap between labels in line with the dot shown in the center of the detection zone. Then push the AUTOSET button marked "Translucent".

Note: This sensor cannot detect transparent labels.

INVERT OUTPUT: The status of the red LED and output transistors can be inverted by pressing both buttons simultaneously. When the output status has been inverted, the red LED and the output transistors will turn off when the label comes into view.

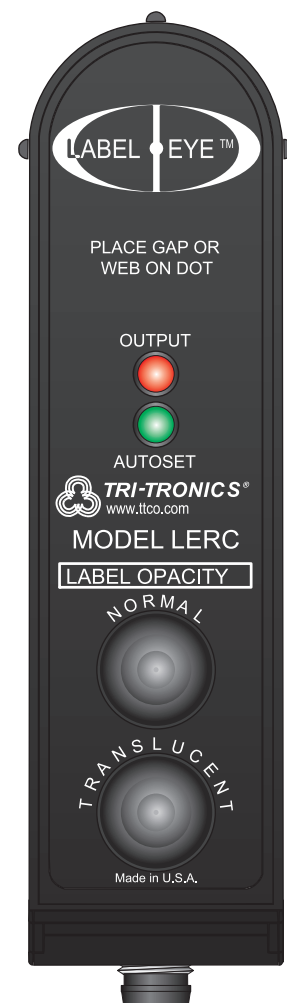

SPECIFICATIONS



SUPPLY VOLTAGE

- 10 to 30Vdc
- Polarity Protected
- Intended for use in class two circuits

CURRENT REQUIREMENTS

- 45 milliamps (exclusive of load)

OUTPUT TRANSISTORS

- (1) NPN and (1) PNP output transistors
- Sensor outputs can sink or source up to 150 milliamps (current limit)
- All outputs are continuously short circuit protected

REMOTE AUTOSET INPUT

- opto isolated momentary sinking input (10 milliamps)
- Note: Remote models only*

RESPONSE TIME

- Light state response = 100 microseconds
- Dark state response = 100 microseconds

LED LIGHT SOURCE

- High intensity red LED
- Pulse modulated

PUSH BUTTON CONTROL

- Automatic set-up routines based on web opacity
- One push button set-up
- Simultaneously pushing both buttons inverts the output

HYSTERESIS

- Minimal hysteresis promotes the detection between the backing material and the label depending on the settings

LIGHT IMMUNITY

- Responds to sensor's pulsed modulated light source ... immune to most ambient light

INDICATORS

- Green LED flashes when AUTOSET routine is activated and stays illuminated when AUTOSET is completed
 - Red LED illuminates when sensors output transistors are ON.
- Note: The status of the output transistors can be inverted by pushing both buttons simultaneously. If Output LED flashes, a short circuit condition exists.*

AMBIENT TEMPERATURE

- -40°C to 70°C (-40°F to 158°F)

RUGGED CONSTRUCTION

- Chemical resistance to harsh cleaners such as detergents, alcohols, and ketones
- Type 1 Enclosure
- Conforms to heavy industry grade CE and UL requirements



RoHS Compliant
Product subject to change without notice.

Model Numbers:

Label•Eye	Description
LER	Red LED, 4 Conductor 6ft Cable
LERC	Red LED, 4-pin M8 Connector
LERR	Red LED, 5 Conductor, 6ft Cable
LERRC-M12	Red LED, 5-Pin M12 Pigtail Connector
LERC-M12	Red LED, 4-Pin M12 Pigtail Connector

Nano Cable (M8) Selection Guide

P/N	Length	Thread Coupling
GEC-6	6ft (1.8m)	Straight Female
GEC-15	15ft (4.6m)	Straight Female
RGEC-6	6ft (1.8m)	90° Female
RGEC-15	15ft (4.6m)	90° Female

DIMENSIONS

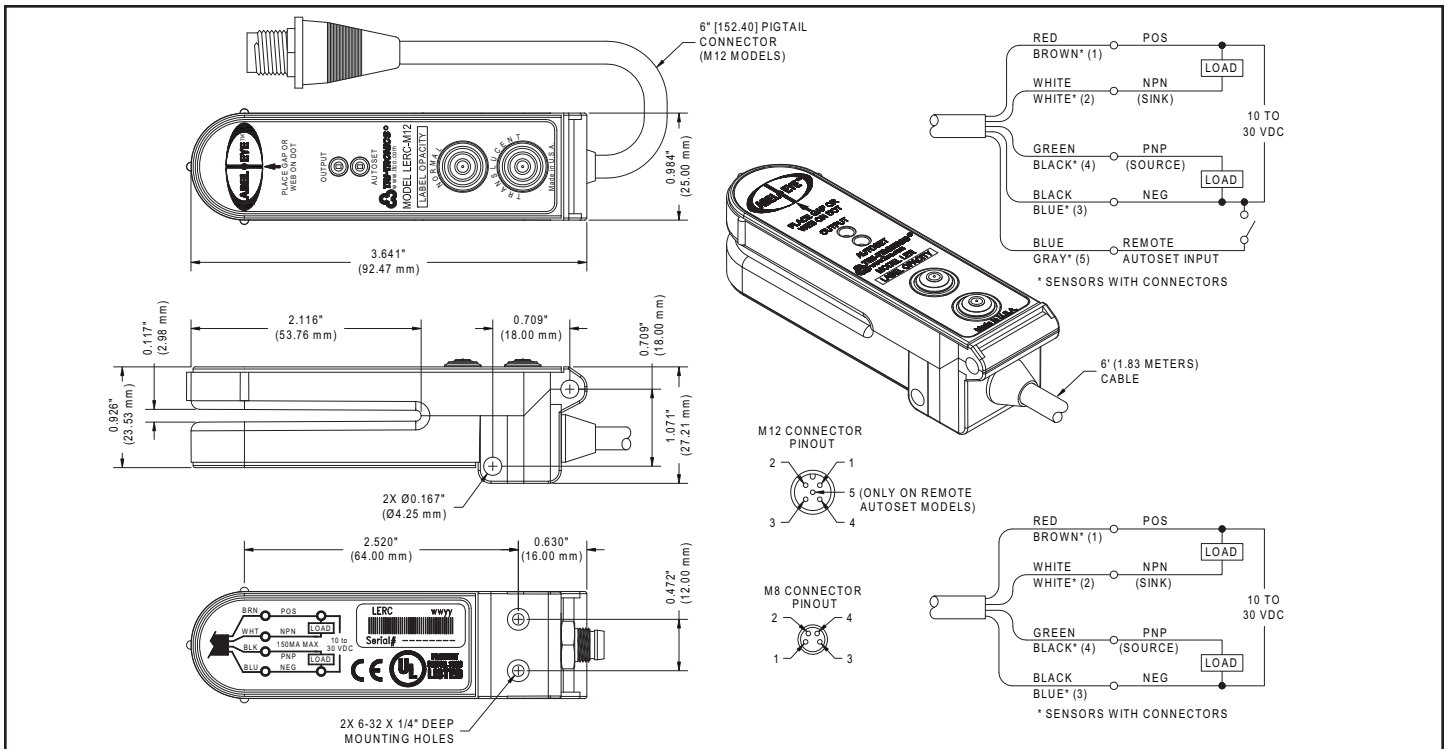

P.O. BOX 25135, TAMPA, FL 33622-5135
813-886-4000 / 800-237-0946
tco.com / info@tco.com

System

ASSEMBLY TITLE: FRAME ASSEMBLY

GENERAL FUNCTION:

- Provides solid mounting for labeling head if not installed on a system that allows for vertical and horizontal adjustment.
- Allows for vertical and horizontal adjustment in the setup of the labeling head operation.

SET-UP AND ADJUSTMENTS:

- Rotate leveling pads to appropriate position. Secure locknut when proper height is achieved.
- Using ratchet handle, adjust labeling head vertical and horizontal position.

MAINTENANCE:

- Clean wipe down rails with clean cloth.

ITEM	QTY	PART NO.	DESCRIPTION	PARENT ITEM
1	4	729006-000	CAP INSERT FOR 2 X 4 TUBE	22529-044S
2	4	791449-000	SWIVEL CASTER	22529-044S
3	4	793020-000	LEVELING MOUNT	22529-044S
4	4	B22787-000	CONVEYOR RISER	22529-044S
5	1	D24424-044S	WELDED FRAME ASSEMBLY	22529-044S
6	2	D24425-000	WIRE COVER	22529-044S

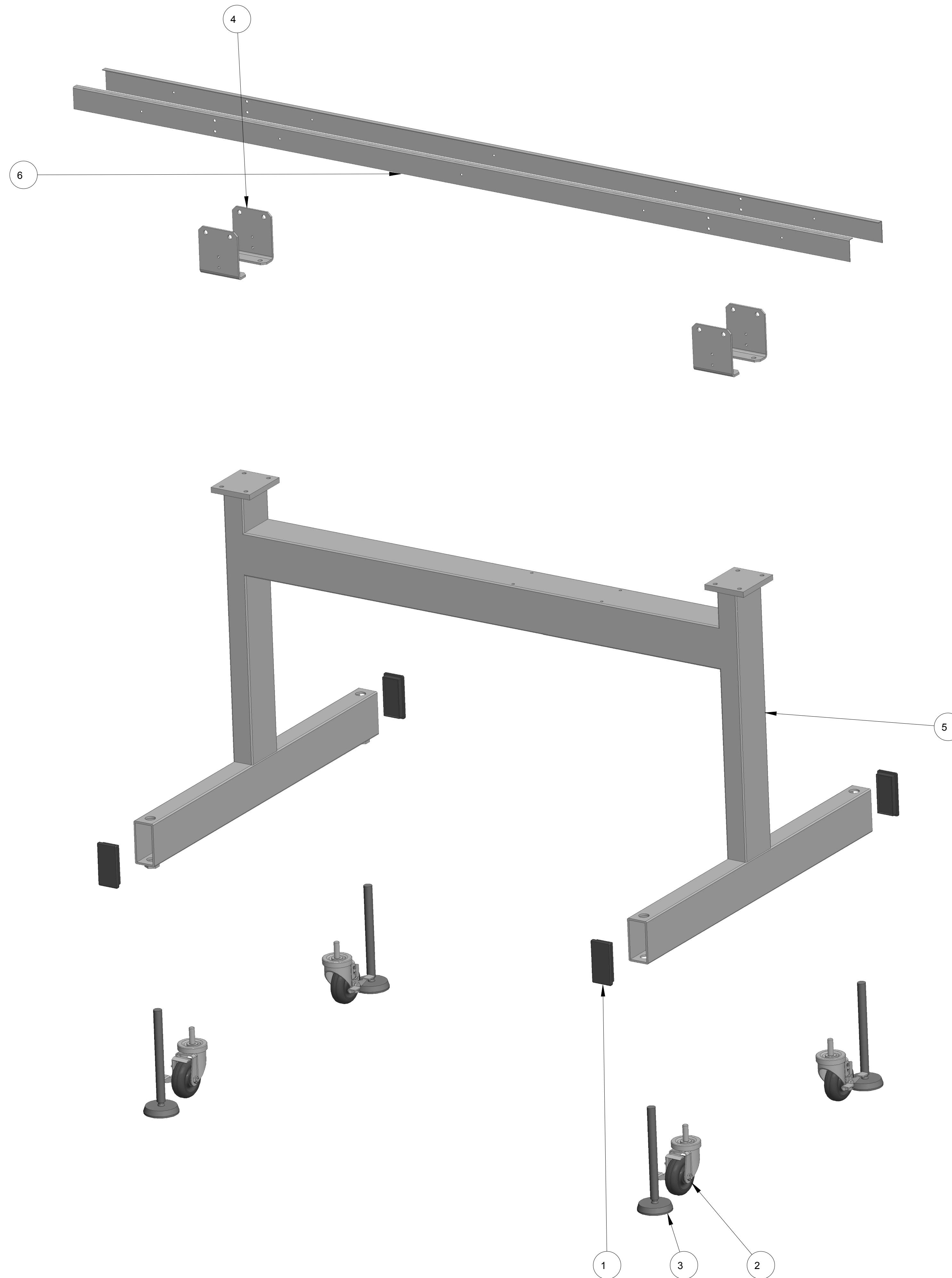

REV	DATE	DESCRIPTION	BY
A	11-27-17	NEW DRAWING	TJS

THIS IS A PRO-ENGINEER DOCUMENT AND MAY NOT BE MODIFIED MANUALLY

UNLESS OTHERWISE SPECIFIED DIMENSIONAL TOLERANCE XX- .1 XXX- .005 ANGLES ± .30°	QUADREL LABELING SYSTEMS 7670 JENTHER DRIVE MENTOR, OHIO 44060 (440) 602-4700	SCALE DATE DRAWN BY	3/16 11-27-17 TJS
	CONVEYOR MTG FRAME		
SURFACE FINISH 125 BREAK ALL EDGES .005/.015 CORNER RADIUS .010/.030	MAT'L	22529-044S	22529-044S

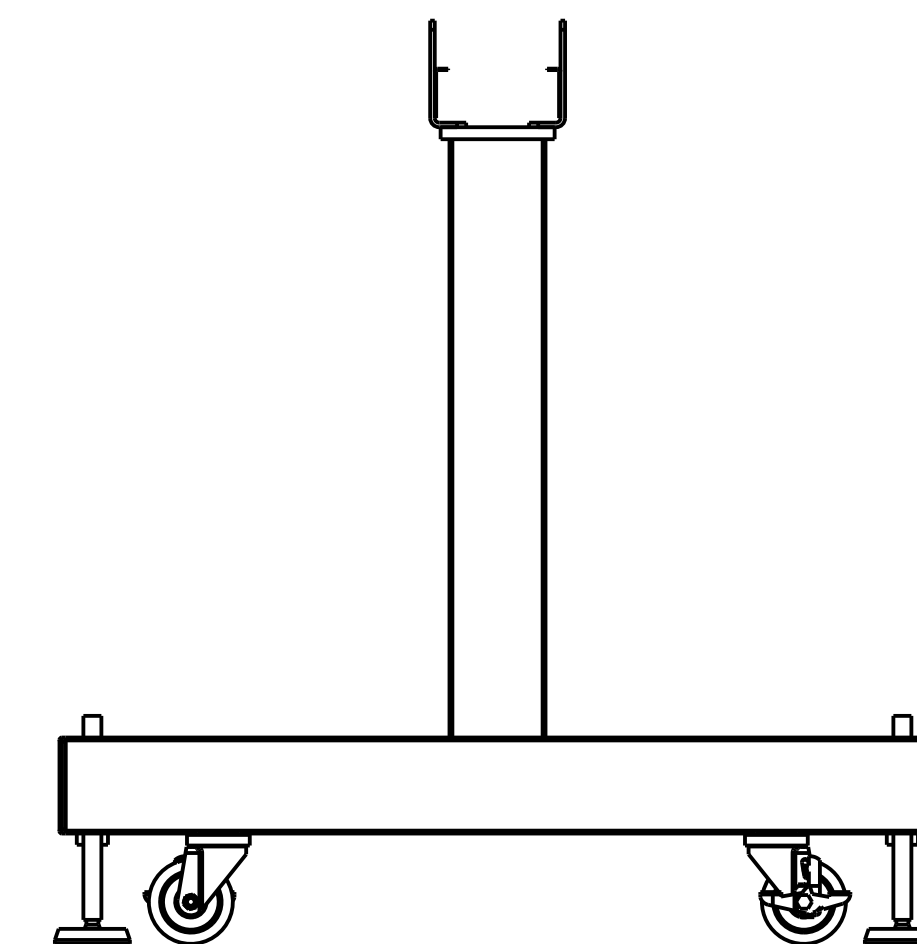
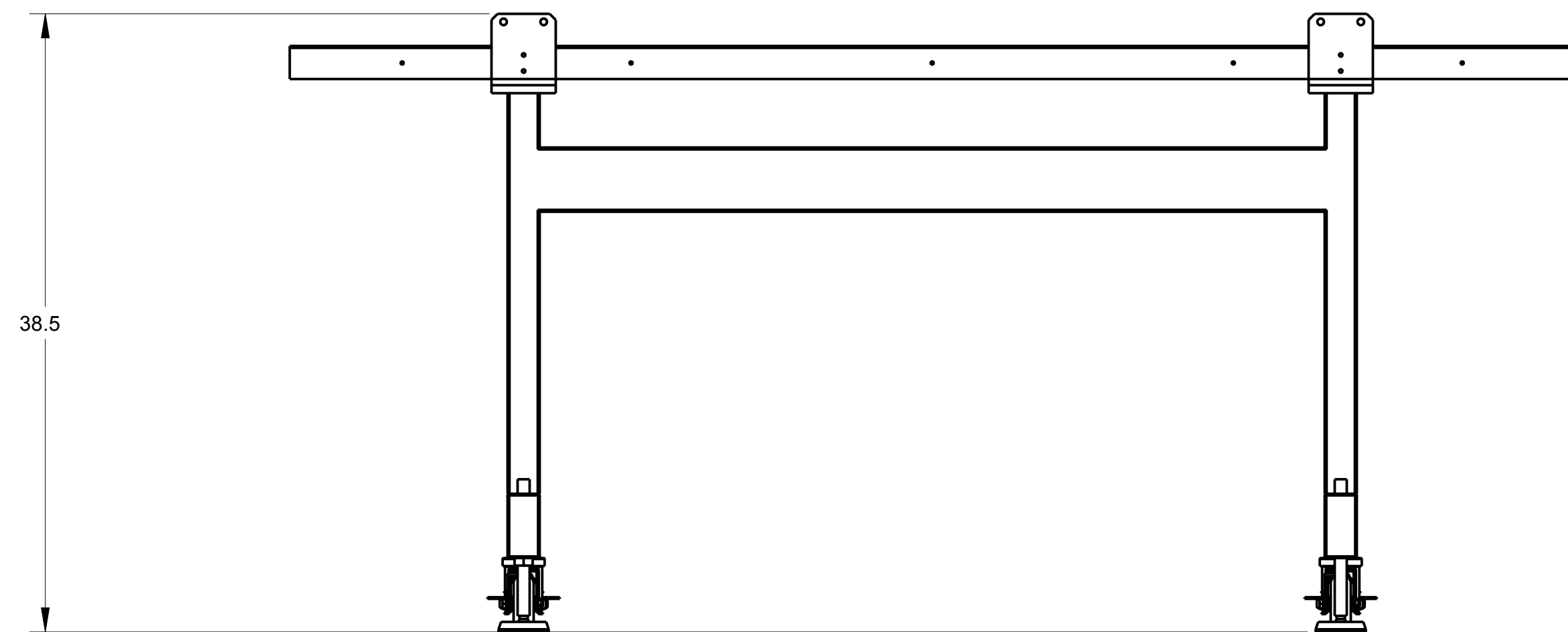
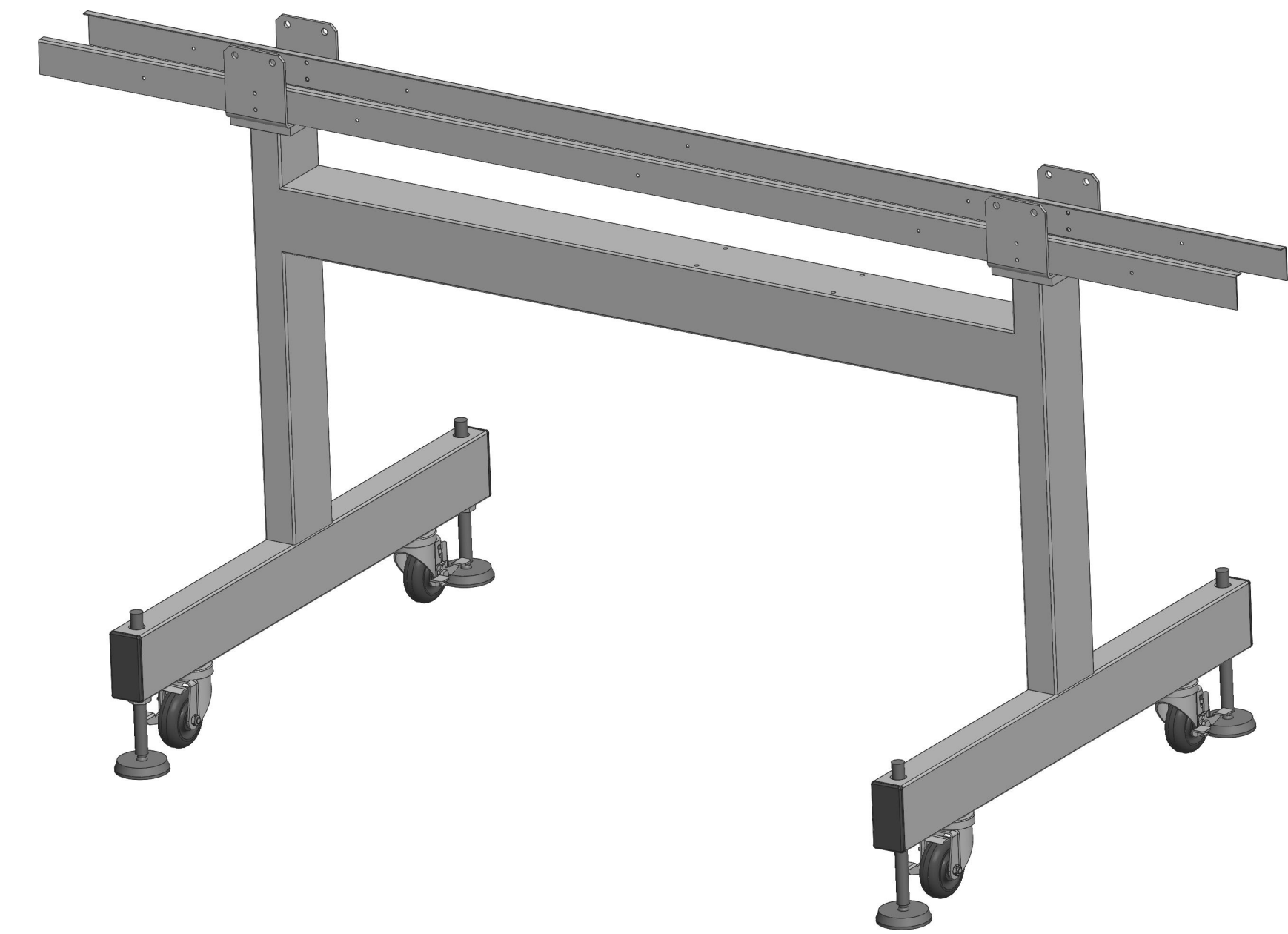
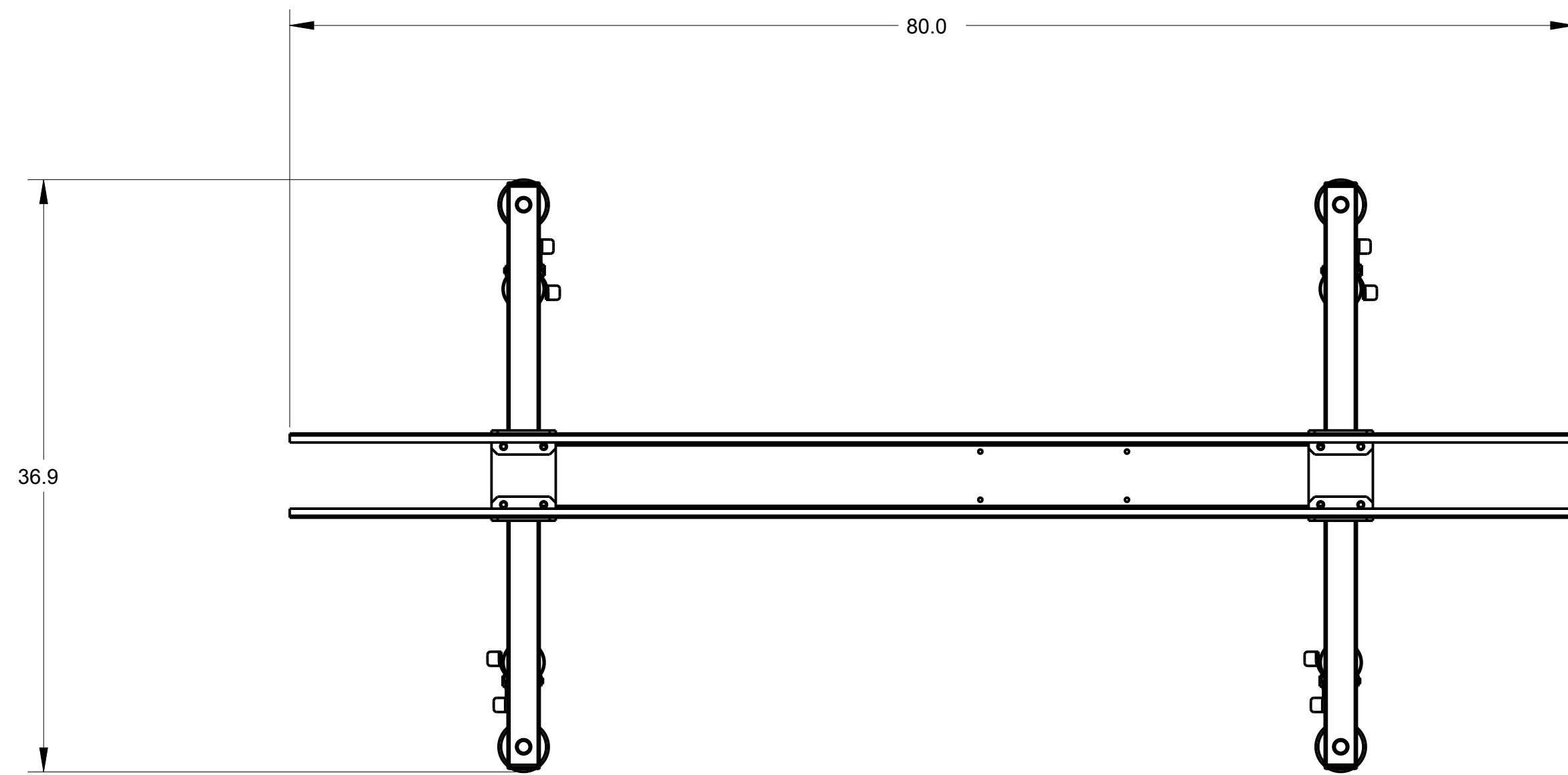

UNLESS OTHERWISE SPECIFIED DIMENSIONAL TOLERANCE		X± .1 XX± .01 XXX± .005 ANGLES ± .30°	
SURFACE FINISH 125 BREAK ALL EDGES .005/.015 CORNER RADIUS .010/.030		QUADREL LABELING SYSTEMS 7670 JENTHER DRIVE MENTOR, OHIO 44060 (440) 602-4700	
MAT'L		22529-044S	22529-044S

THIS IS A PRO-ENGINEER DOCUMENT AND MAY NOT BE MODIFIED MANUALLY			
REV	DATE	DESCRIPTION	BY
A	11-27-17	NEW DRAWING	TJS
SCALE		1/8	
DATE		11-27-17	
DRAWN BY		TJS	
CONVEYOR MTG FRAME			

ITEM	QTY	PART NO.	DESCRIPTION	PARENT ITEM
1	1	729006-000	CAP INSERT FOR 2 X 4 TUBE	22615-010
2	1	791449-000	SWIVEL CASTER	22615-010
3	1	A24366-000	MODIFIED LEVELING MOUNT	22615-010
4	1	D25140-010	SUPPORT LEG	22615-010

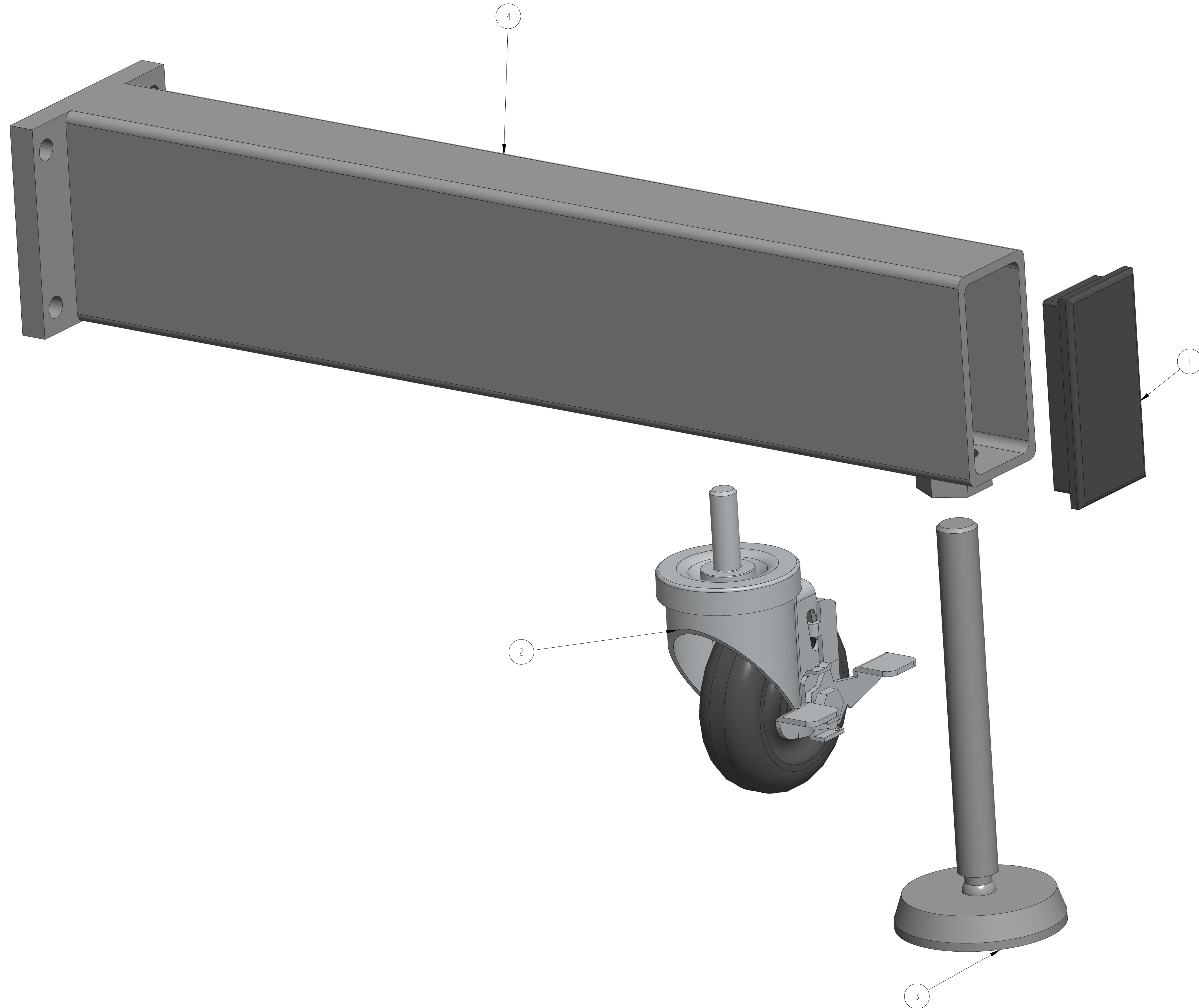

REV	DATE	DESCRIPTION	BY
A	Aug-19-22	NEW DRAWING	TJS

THIS IS A PRO-ENGINEER DOCUMENT AND MAY NOT BE MODIFIED MANUALLY

QUADREL LABELING SYSTEMS
 7670 JENTHER DRIVE
 MENTOR, OHIO 44060
 (440) 602-4700

SCALE: 1/1
 DATE: Aug-19-22
 DRAWN BY: TJS

ELECTRICAL BOX SUPPORT LEG

MAT'L	22615-010	22615-010
-------	-----------	-----------

UNLESS OTHERWISE SPECIFIED
 DIMENSIONAL TOLERANCE
 .XX ± .01
 .XXX ± .005
 ANGLES ± 30°
 SURFACE FINISH: 125
 BREAK ALL EDGES: .005/.015
 CORNER RADIUS: .010/.030

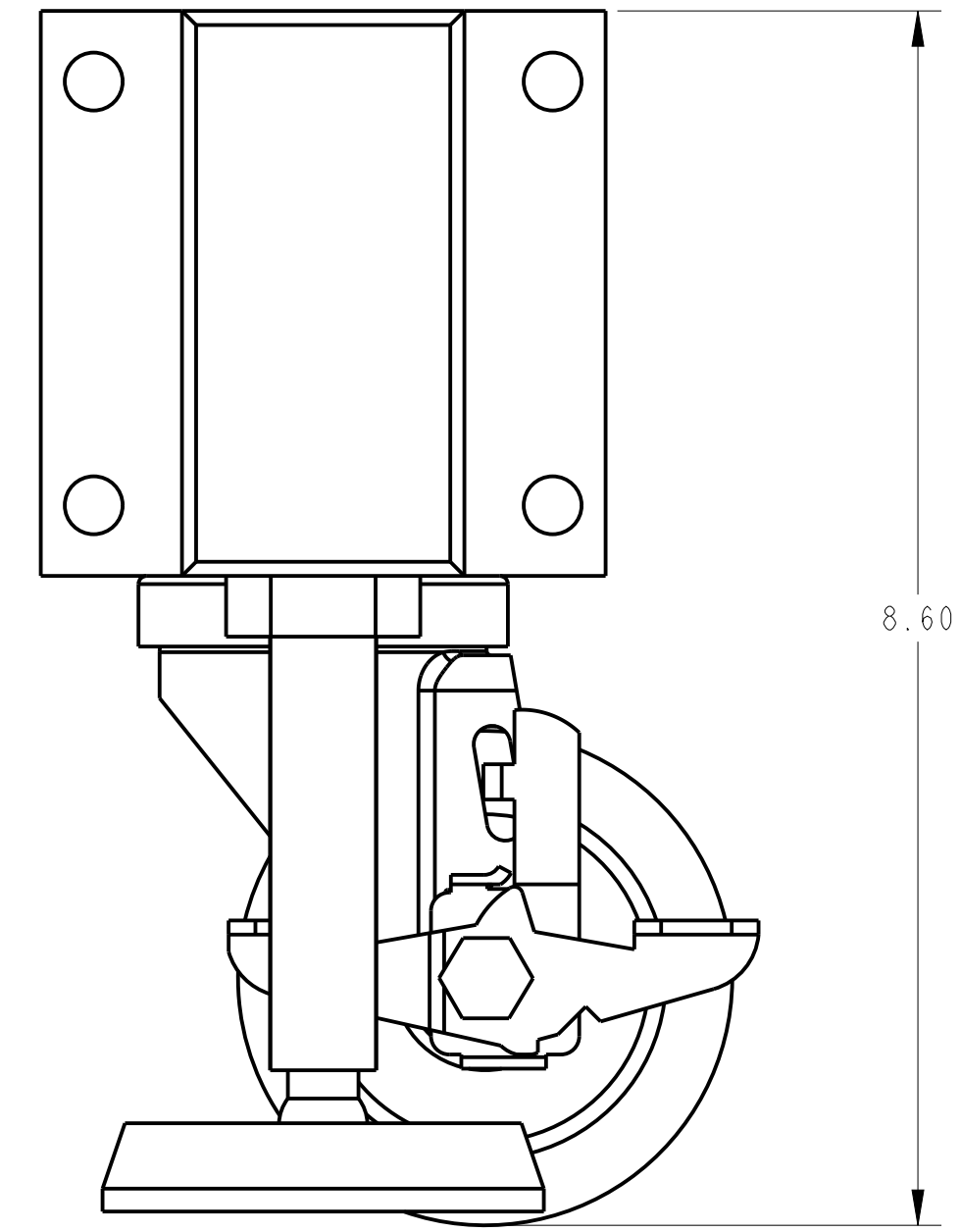
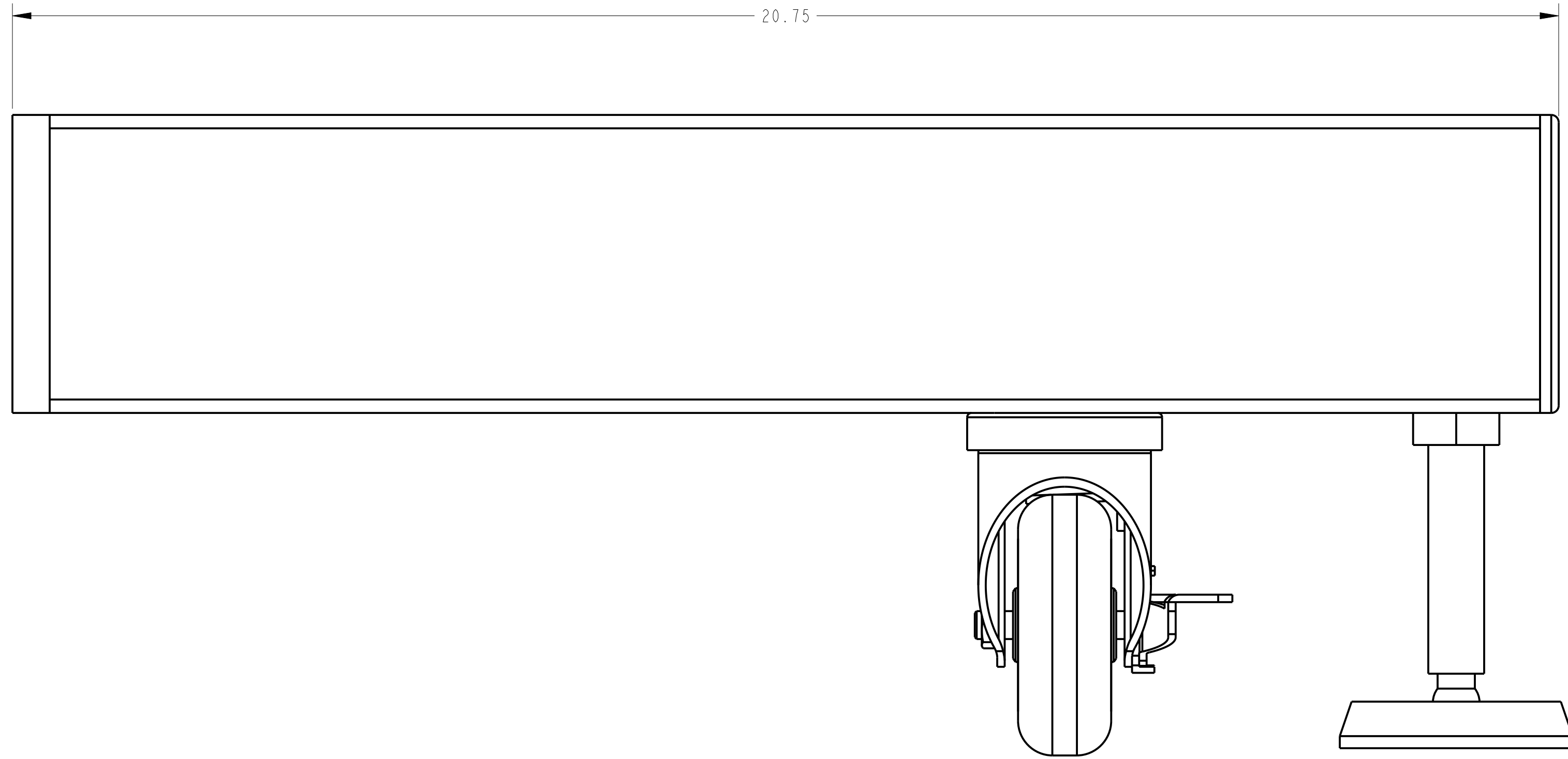
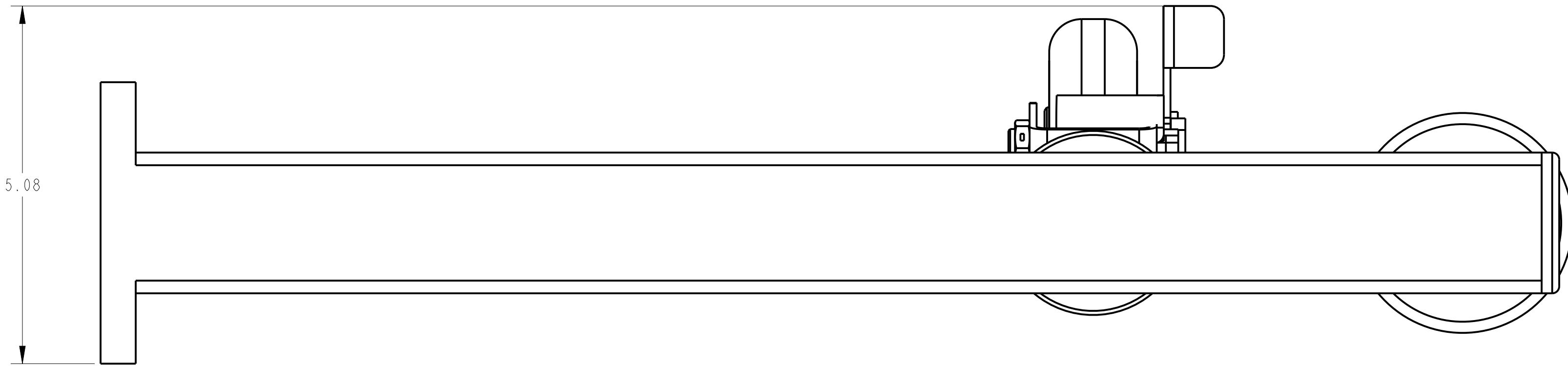
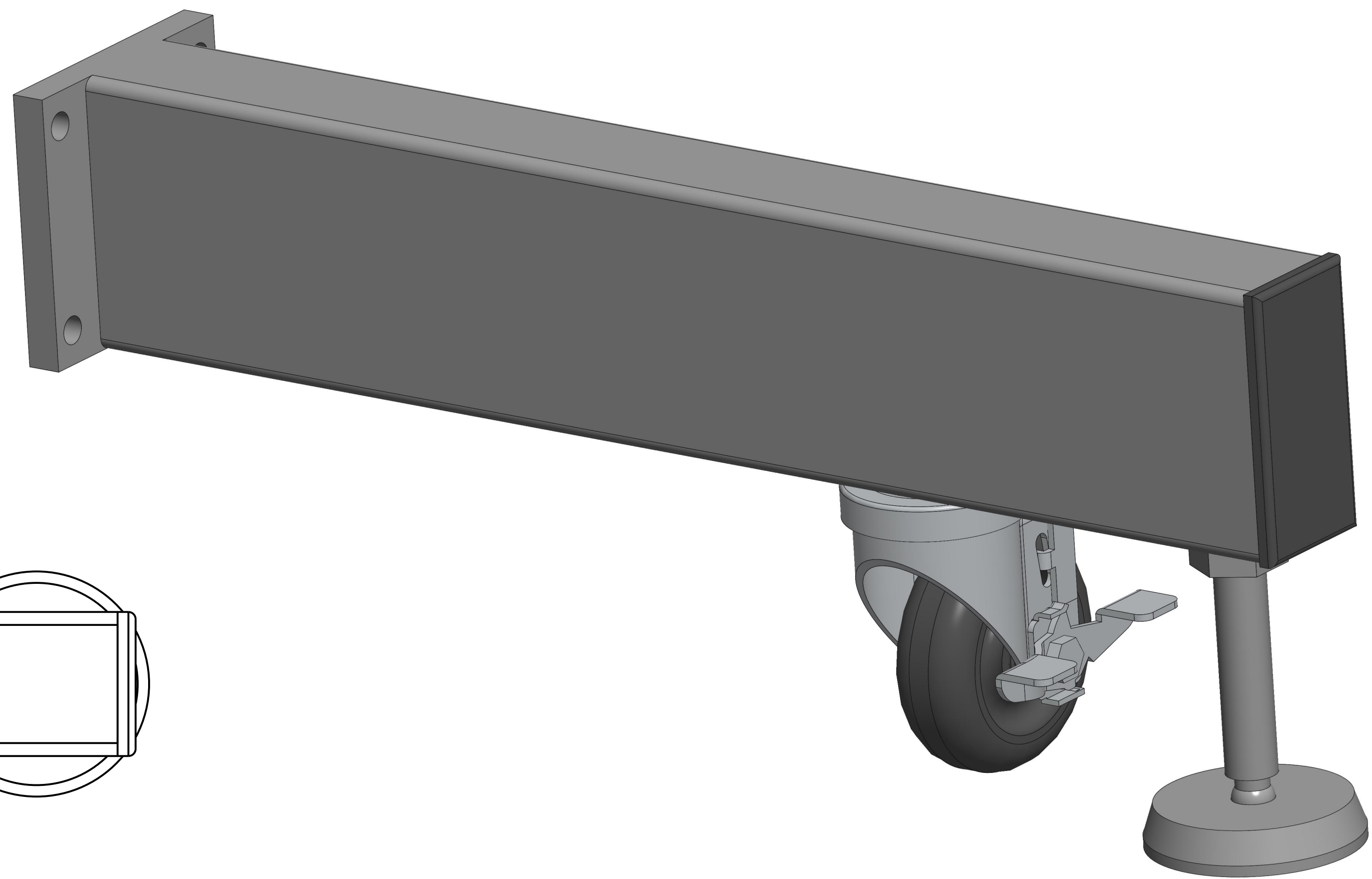

THIS IS A PRO-ENGINEER DOCUMENT AND MAY NOT BE MODIFIED MANUALLY

REV	DATE	DESCRIPTION	BY
A	Aug-19-22	NEW DRAWING	TJS

UNLESS OTHERWISE SPECIFIED
 DIMENSIONAL TOLERANCE
 .x ± .1
 .xx ± .01
 .xxx ± .005
 ANGLES ± 30°

SURFACE FINISH 125
 BREAK ALL EDGES .005/.015
 CORNER RADIUS .010/.030

QUADREL LABELING SYSTEMS
 7670 JENTHER DRIVE
 MENTOR, OHIO 44060
 (440) 602-4700

SCALE 3/4
 DATE Aug-19-22
 DRAWN BY TJS

ELECTRICAL BOX SUPPORT LEG
 MAT'L 22615-010 22615-010

ASSEMBLY TITLE: NON-INTEGRATED CONVEYOR

GENERAL FUNCTION:

- To transfer the product to the labeling heads at a predetermined speed.
- To provide retention for the head support and guide rails.

SET-UP AND ADJUSTMENTS:

- Adjust conveyor to proper working height by rotating leveling pads to appropriate position. Secure locknut when proper height is achieved.
- Using ratchet handles, adjust guide rails to the product.
- Adjust conveyor speed by means of conveyor speed potentiometer (if applicable) located in the remote electronics enclosure mounted to the conveyor, or through the operator's touchscreen if provided.

MAINTENANCE:

- The conveyor drive chain must be greased with white lithium grease.
- Do not allow chain and sprockets to run dry, lubricate periodically.
- The gear motor gearbox should be checked quarterly and filled with Synthetic based Tivela Oil SC320 or an ISO320 Gear Lube lubricant.
- Grease flange bearings often to prevent them from running dry.

TROUBLESHOOTING:

PROBLEM

- Excessive Noise

- Chain too loose

- Uneven wear on sprockets.
- Shaft not running concentric

WHAT TO DO

- Realign sprocket.
- Check if chain and sprockets are lubricated. If dry, lubricate as discussed above.
- Slide gear motor downward to create more tension on chain.
- Realign sprockets.
- Replace flange bearing.



ITEM	QTY	PART NO.	DESCRIPTION	PARENT ITEM
1	1	171033-001	BEARING	22528-520
2	1	192571-000	TIMING BELT 150XL037	22528-520
3	1	202123-000	CUBE ENCODER	22528-520
4	1	342018-000	IDLER WHEEL	22528-520
5	1	342019-002	DRIVE SPROCKET, MODULINE	22528-520
6	1	351166-000	TIMING PULLEY	22528-520
7	75	361174-000	TABLE TOP CHAIN LINK	22528-520
8	1	413016-000	GEARMOTOR 3/8HP-57RPM AC	22528-520
9	32	791838-000	SPACER	22528-520
10	2	791884-109	WEAR STRIP, FLAT BAR CLIP-ON (7ft)	22528-520
11	1	792361-000L-93	WEAR STRIP, FLAT BAR CLIP-ON (6ft)	22528-520
12	1	792361-000R-93	WEAR STRIP, FLAT BAR CLIP-ON (6ft)	22528-520
13	1	A23098-000	IDLER SHAFT	22528-520
14	2	A23099-000	CHAIN BELT GUIDE	22528-520
15	1	A25119-500	DRIVE SHAFT PULLEY	22528-520
16	1	A25127-000	ENCODER COVER PLATE	22528-520
17	1	B20237-500	CONVEYOR DRIVE SHAFT	22528-520
18	1	D24421-1020	CONVEYOR SIDE WALL	22528-520
19	1	D24421-1021	CONVEYOR SIDE WALL	22528-520

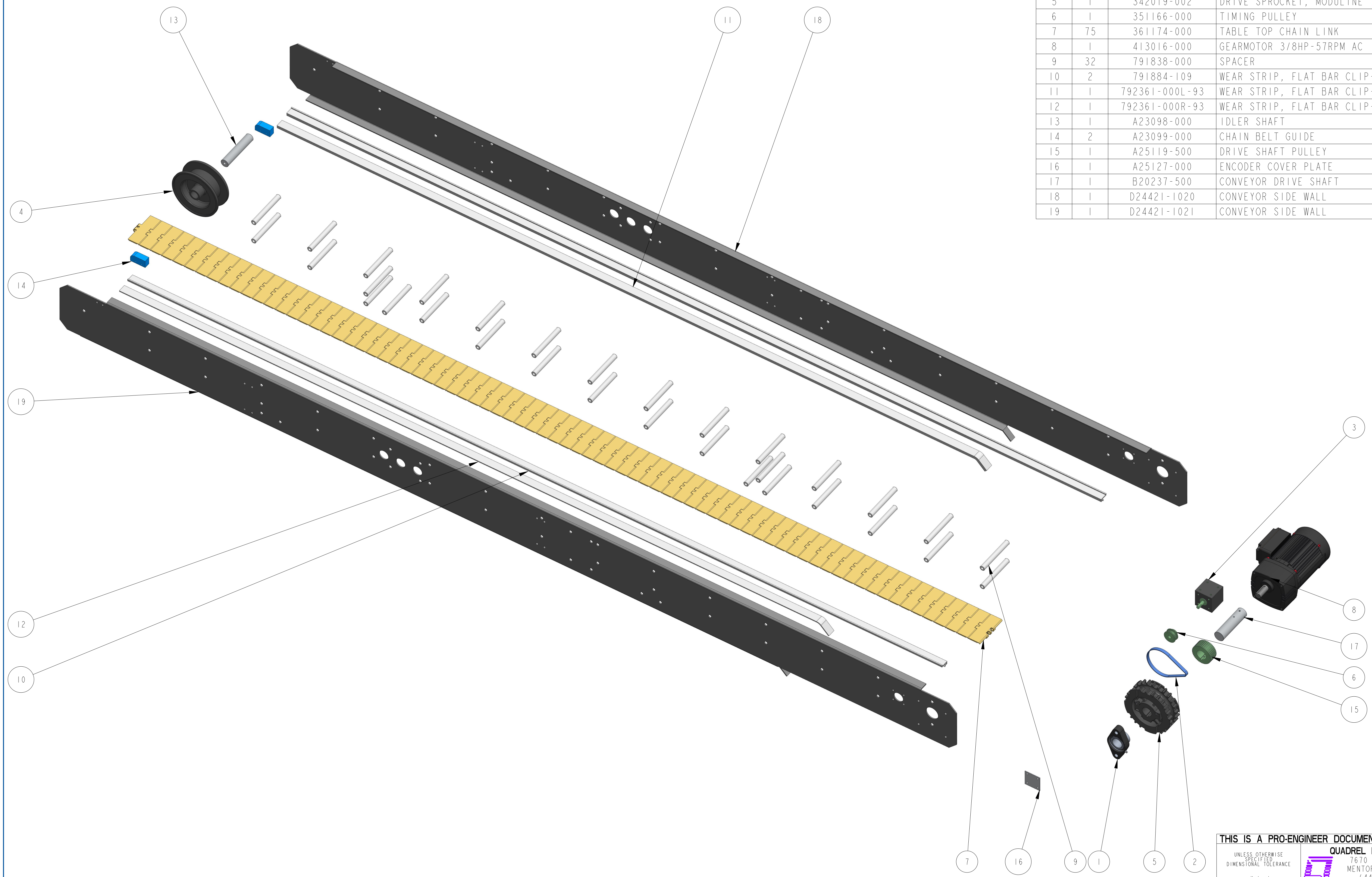

REV	DATE	DESCRIPTION	BY
A	May-24-21	NEW DRAWING	TJS

THIS IS A PRO-ENGINEER DOCUMENT AND MAY NOT BE MODIFIED MANUALLY

UNLESS OTHERWISE SPECIFIED
DIMENSIONAL TOLERANCE
X ± .1
XX ± .01
XXX ± .005
ANGLES ± .30°

SURFACE FINISH 125
BREAK ALL EDGES .005/.015
CORNER RADIUS .010/.030

QUADREL LABELING SYSTEMS
7670 JENTHER DRIVE
MENTOR, OHIO 44060
(440) 602-4700

SCALE: 3/16
DATE: May-24-21
DRW BY: TJS
CHK BY: 03/18/2024-SEM
APPR BY:

OPENLINE CONVEYOR ASSEMBLY

MAT'L 22528-520

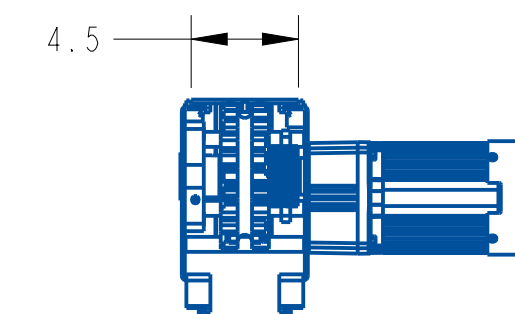
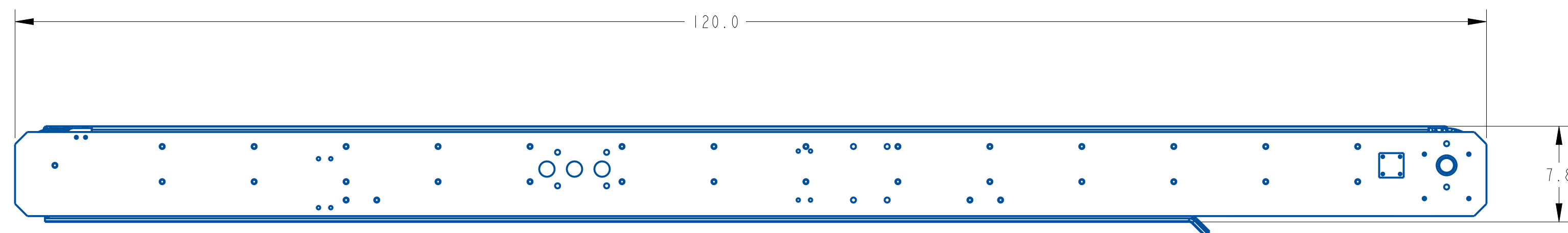
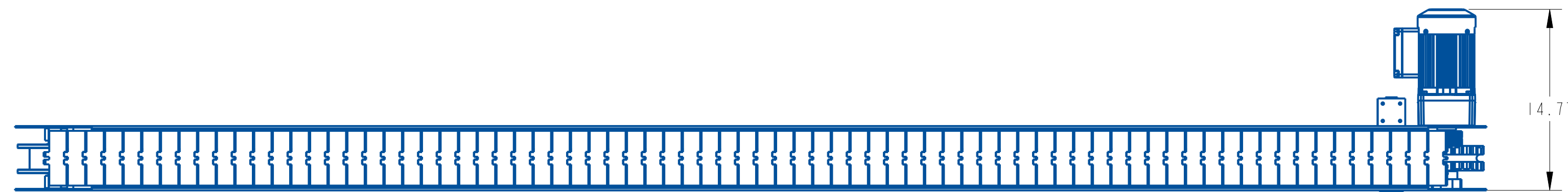
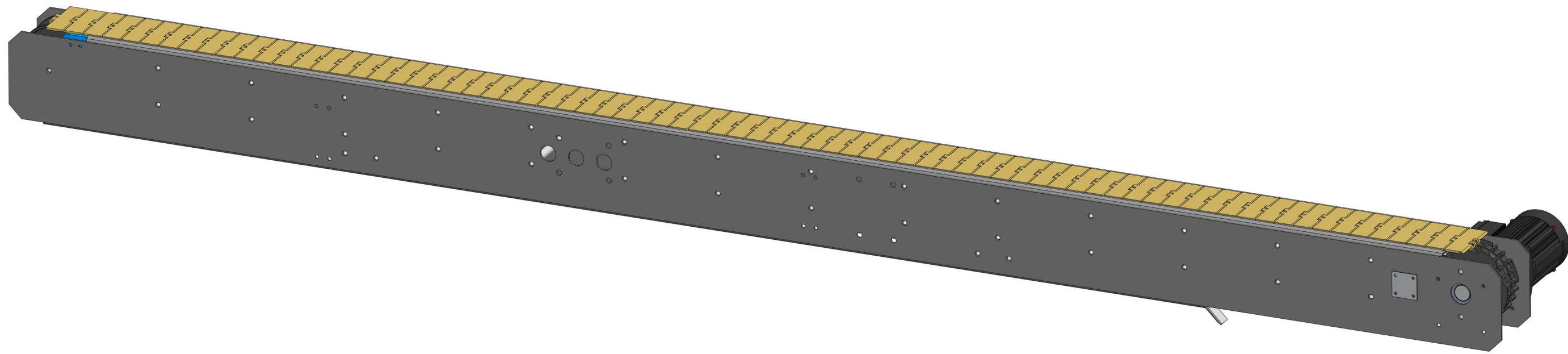

REV	DATE	DESCRIPTION	BY
A	May-24-21	NEW DRAWING	TJS

THIS IS A PRO-ENGINEER DOCUMENT AND MAY NOT BE MODIFIED MANUALLY

UNLESS OTHERWISE SPECIFIED
DIMENSIONAL TOLERANCE
X ± .1
XX ± .01
XXX ± .005
ANGLES ± .30°
SURFACE FINISH 125
BREAK ALL EDGES .005/ .015
CORNER RADIUS .010/ .030
ALL ANGLES ARE 90°

QUADREL LABELING SYSTEMS
7670 JENTHER DRIVE
MENTOR, OHIO 44060
(440) 602-4700

SCALE: 1/8
DATE: May-24-21
DRW BY: TJS
CHK BY: 03/18/2024-SEM
APPR BY:

OPENLINE CONVEYOR ASSEMBLY
MAT'L 22528-520

ITEM	QTY	PART NO.	DESCRIPTION	PARENT ITEM
1	1	791732-000	CLAMP FOR CONICAL SIDE GUIDE	22435-034
2	1	791914-002_06	MYLAR SCALE, QUADREL LOGO	22435-034
3	1	791914-003_06	MYLAR SCALE, QUADREL LOGO, 6" LG.	22435-034
4	1	792711-000	CAP, ORANGE	22435-034
5	2	801308-000	KNOB W/ 1/4-20 STUD	22435-034
6	1	A20875-000	RETAINER BLOCK, CONV. RAIL	22435-034
7	1	A20876-000	RETAINER BLOCK	22435-034
8	1	A21198-199	ADJUSTMENT ROD	22435-034
9	1	A28000-000	CLAMPING ROD ASSEMBLY 6"	22435-034

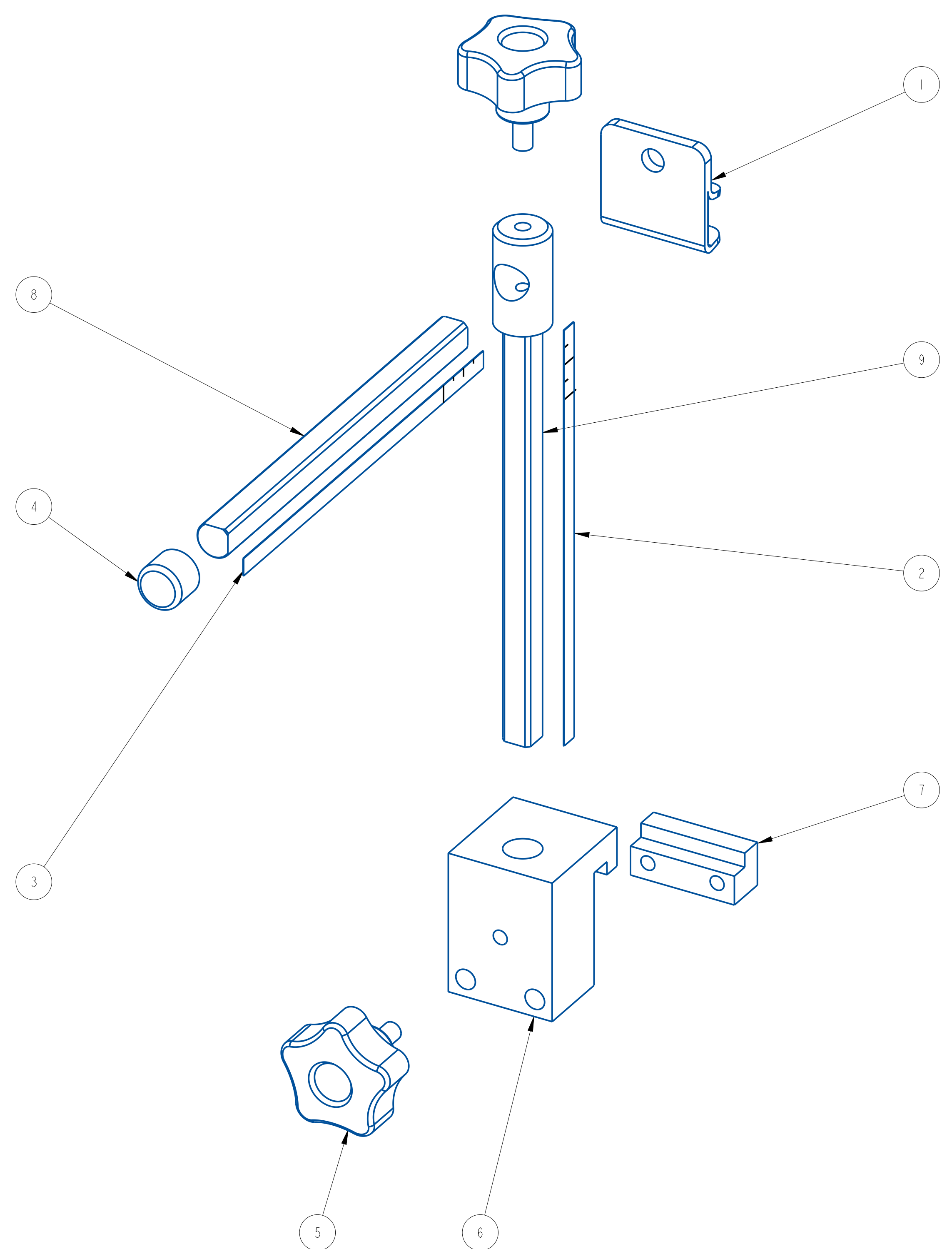

REV	DATE	DESCRIPTION	BY
A	Aug-07-25	NEW DRAWING	TAZ

THIS IS A PRO-ENGINEER DOCUMENT AND MAY NOT BE MODIFIED MANUALLY

QUADREL LABELING SYSTEMS
 7670 JENTHER DRIVE
 MENTOR, OHIO 44060
 (440) 602-4700

SCALE: 1/1
 DATE: Aug-07-25
 DRW BY: TAZ
 CHK BY: 08/28/2025-SEM
 APPR BY:

RAIL KIT WITH SCALES

MAT'L: 22435-034

UNLESS OTHERWISE SPECIFIED
 DIMENSIONAL TOLERANCE
 .XX ± .01
 .XXX ± .005
 ANGLES ± .30°
 SURFACE FINISH 125
 BREAK ALL EDGES .005/0.15
 CORNER RADIUS .010/0.30
 ALL ANGLES ARE 90°

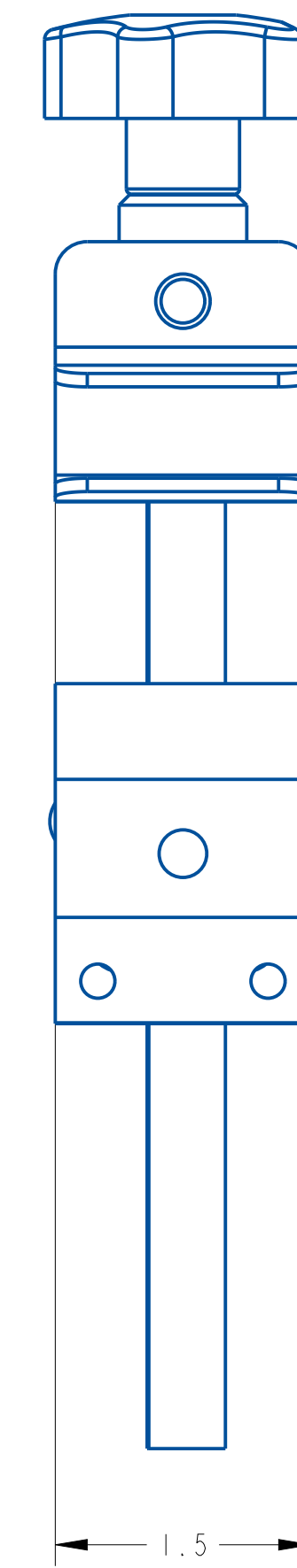
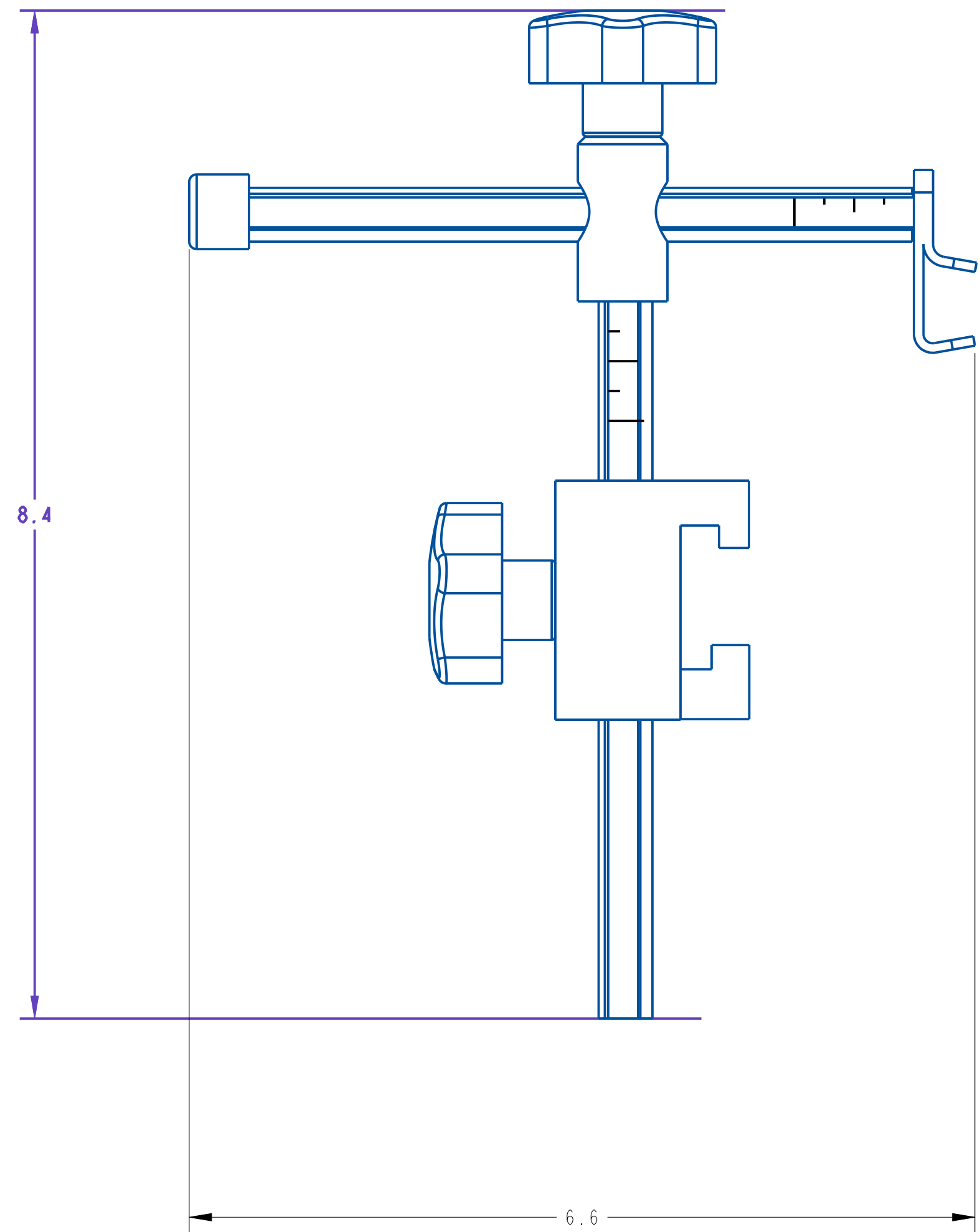
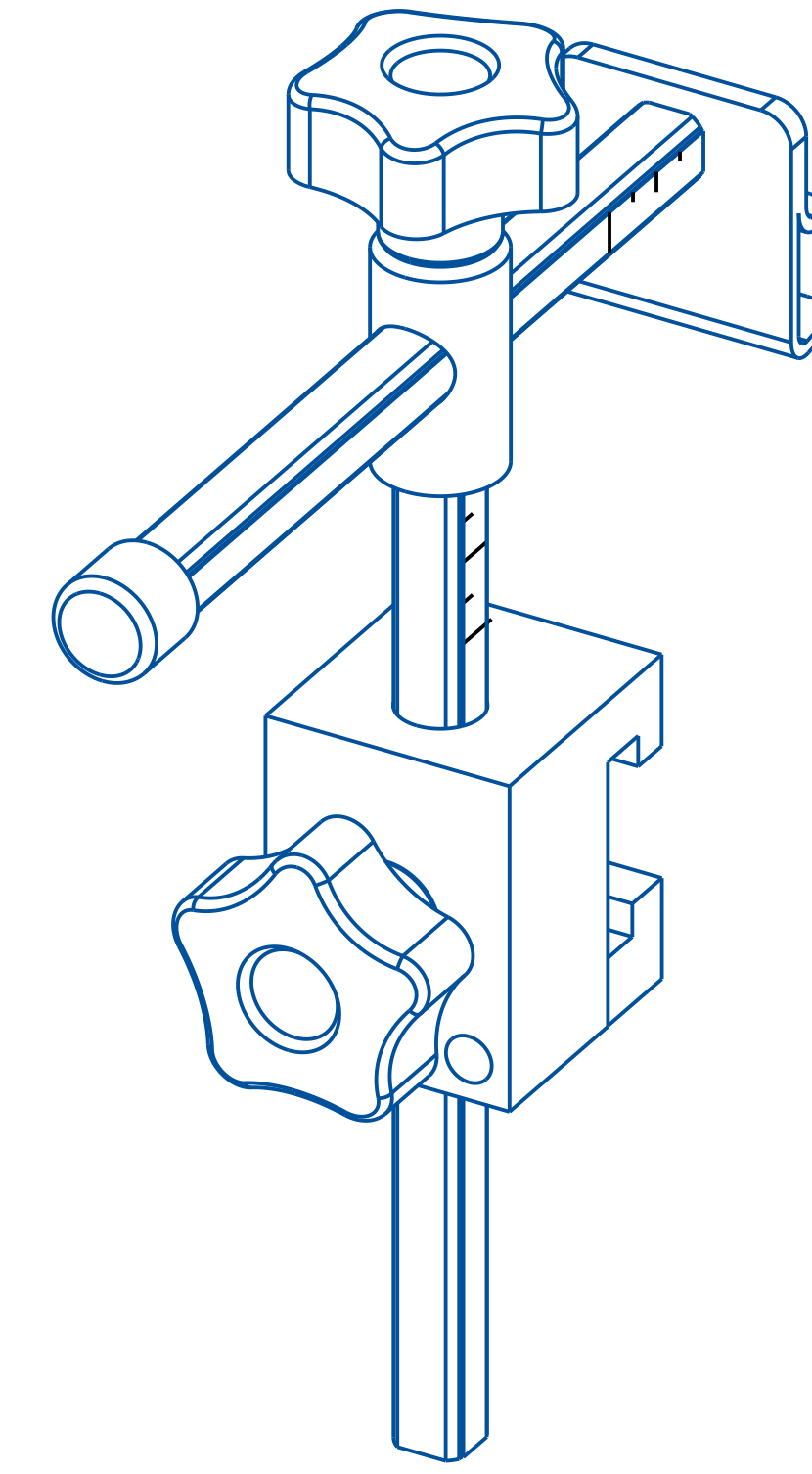
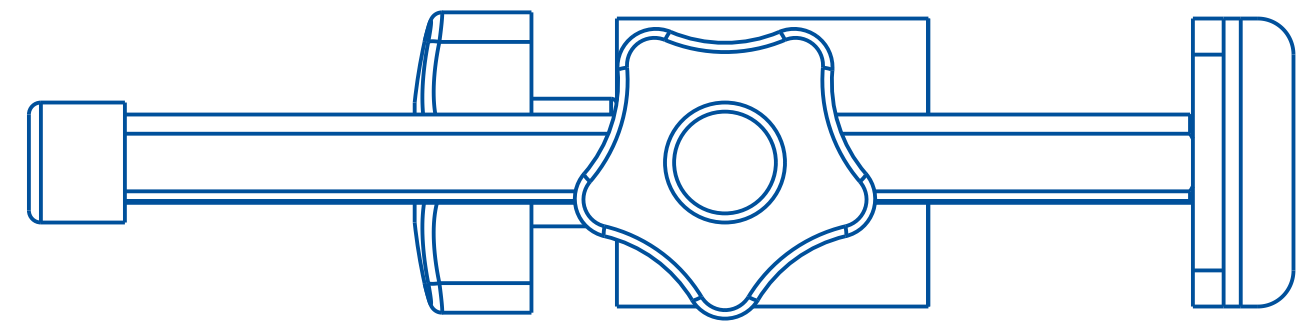

REV	DATE	DESCRIPTION	BY
A	Aug-07-25	NEW DRAWING	TAZ

THIS IS A PRO-ENGINEER DOCUMENT AND MAY NOT BE MODIFIED MANUALLY

UNLESS OTHERWISE SPECIFIED
 DIMENSIONAL TOLERANCE
 .X ± .1
 .XX ± .01
 .XXX ± .005
 ANGLES ± .30°
 SURFACE FINISH 125
 BREAK ALL EDGES .005/.015
 CORNER RADIUS .010/.030
 ALL ANGLES ARE 90°

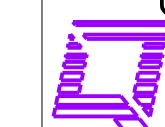

QUADREL LABELING SYSTEMS
 7670 JENTHER DRIVE
 MENTOR, OHIO 44060
 (440) 602-4700

SCALE: 1/1
 DATE: Aug-07-25
 DRW BY: TAZ
 CHK BY: 08/28/2025-SEM
 APPR BY:

RAIL KIT WITH SCALES

MAT'L 22435-034

ITEM	QTY	PART NO.	DESCRIPTION	PARENT ITEM
1	1	221152-005	ENCLOSURE, E-STOP W/ BUTTON	20789-000
2	1	241780-000	STRAIN RELIEF, CABLE	20789-000
3	1	241780-001	STRAIN RELIEF, CABLE PANEL	20789-000
4	1	A25719-000	CYLINDER MOUNTING ANGLE	20789-000

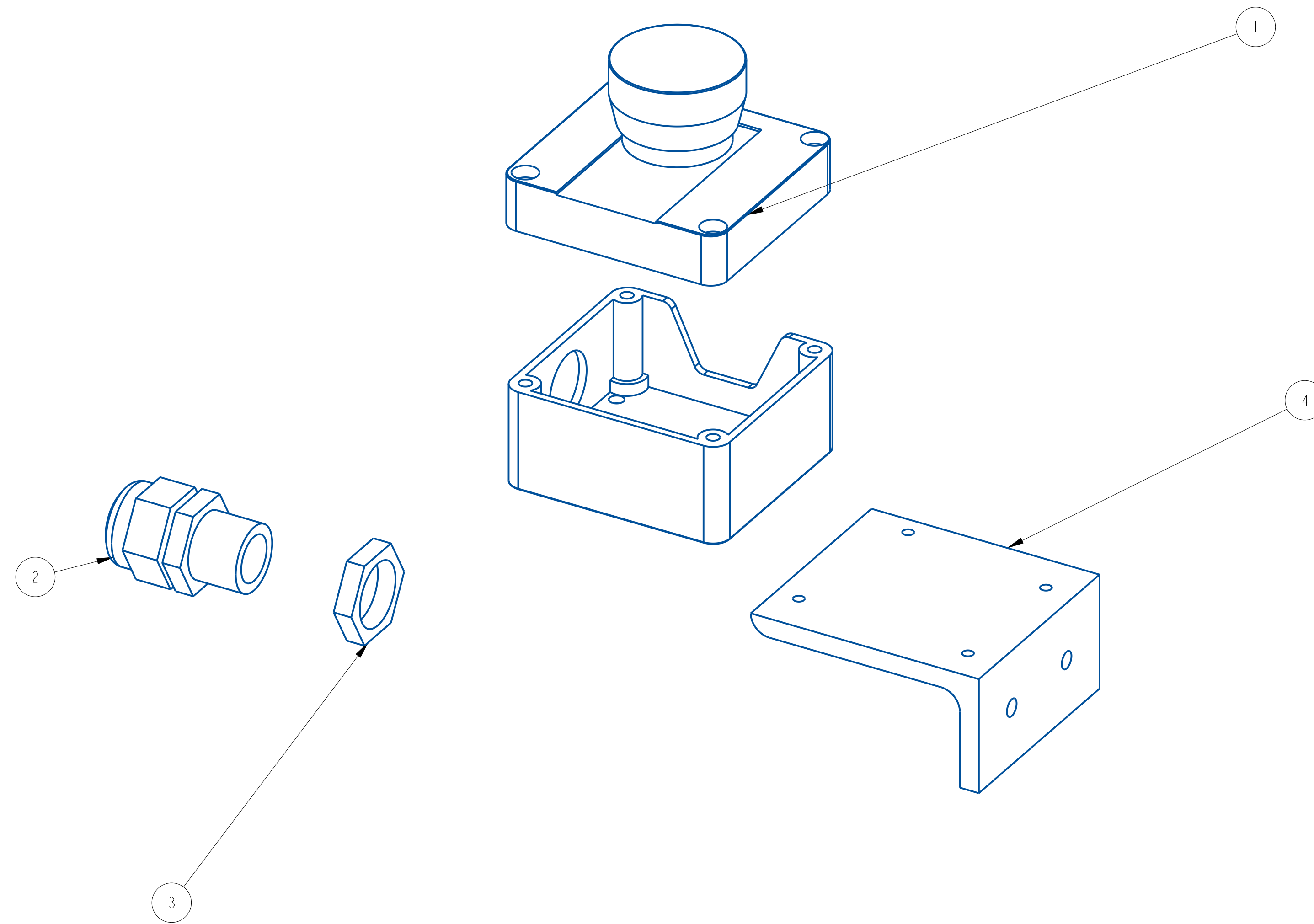

REV	DATE	DESCRIPTION	BY
A	8-29-16	NEW DRAWING	TJS

THIS IS A PRO-ENGINEER DOCUMENT AND MAY NOT BE MODIFIED MANUALLY

UNLESS OTHERWISE SPECIFIED DIMENSIONAL TOLERANCE	 QUADREL LABELING SYSTEMS 7670 JENTHER DRIVE MENTOR, OHIO 44060 (440) 602-4700	SCALE: 1/1 DATE: 8-29-16 DRW BY: TJS CHK BY: 03/08/2024-SEM APPR BY:
EMERGENCY STOP ASSEMBLY		
SURFACE FINISH 125 BREAK ALL EDGES .005/0.15 CORNER RADIUS .010/0.30	MAT'L	20789-000

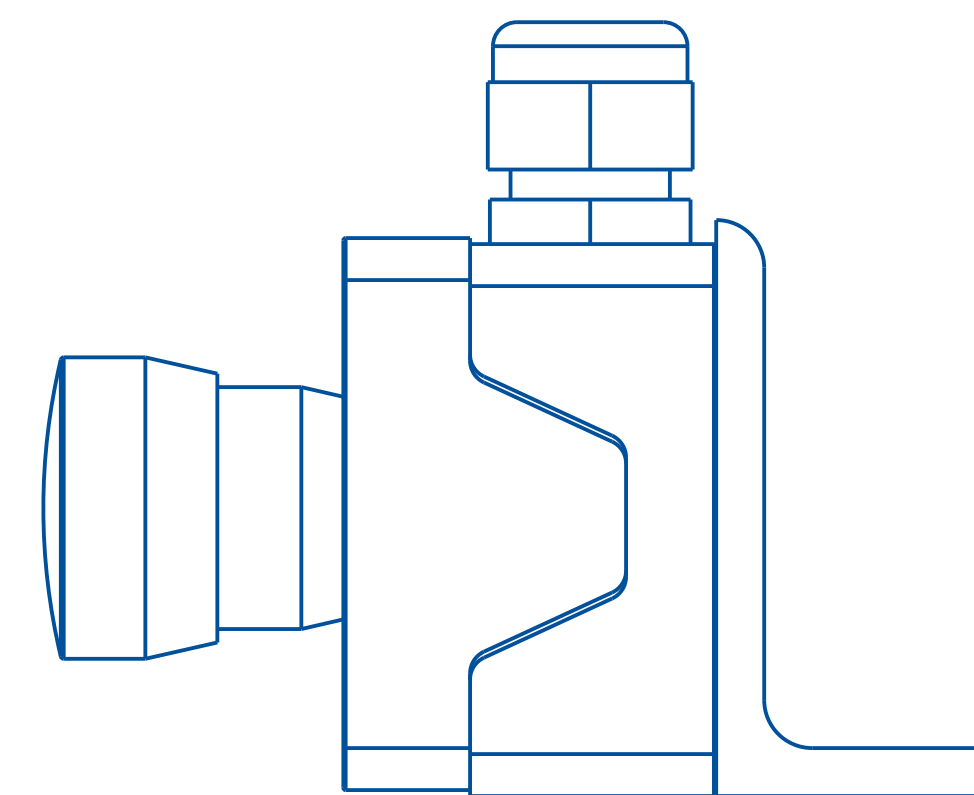
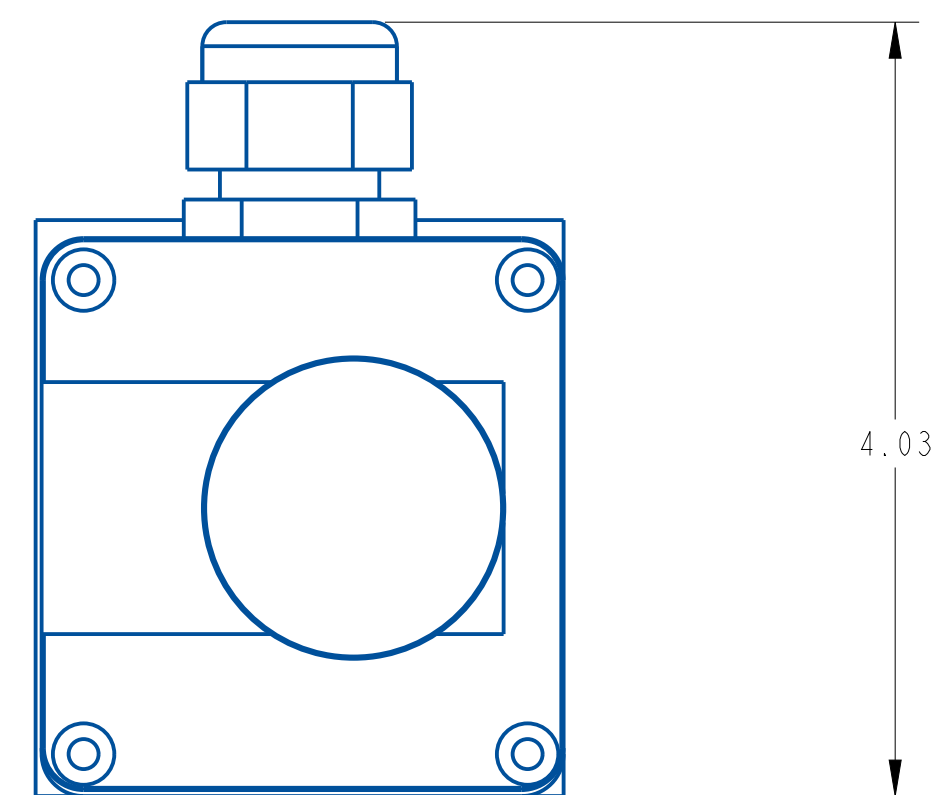
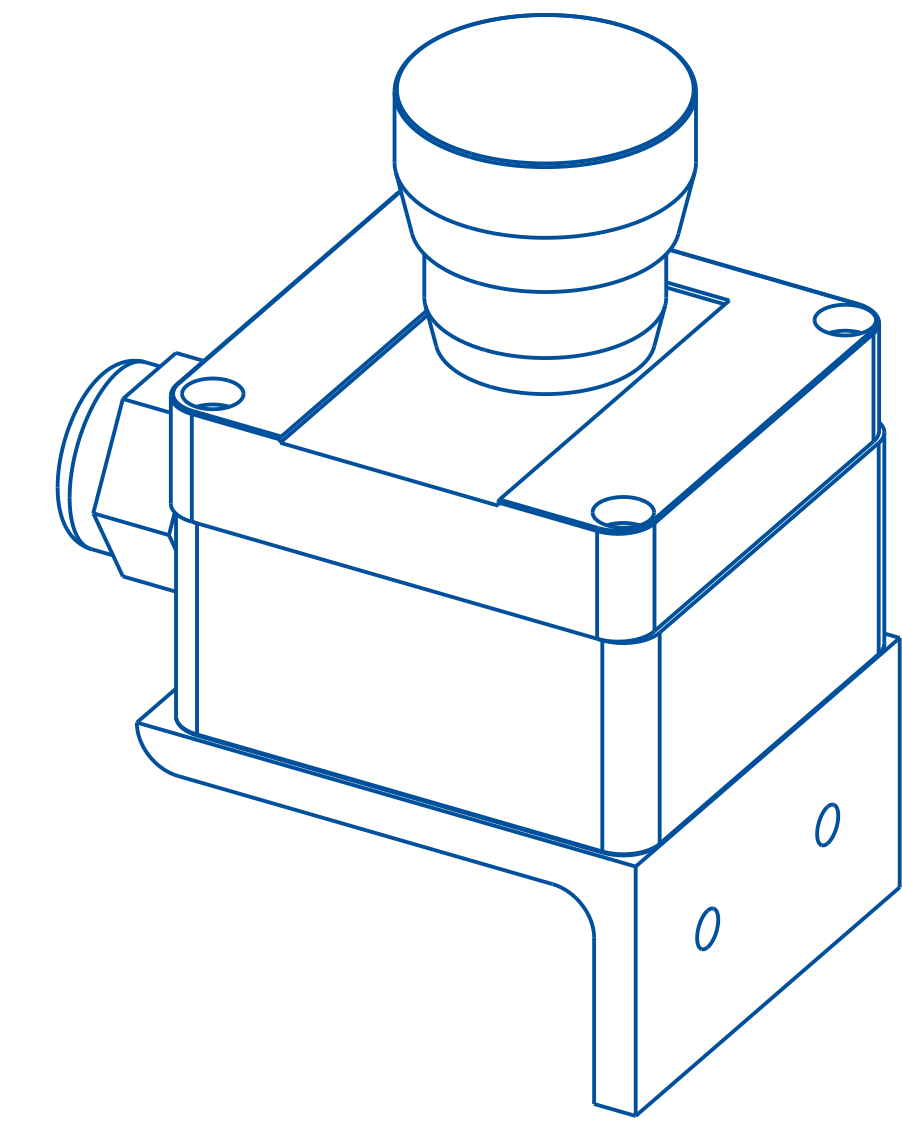
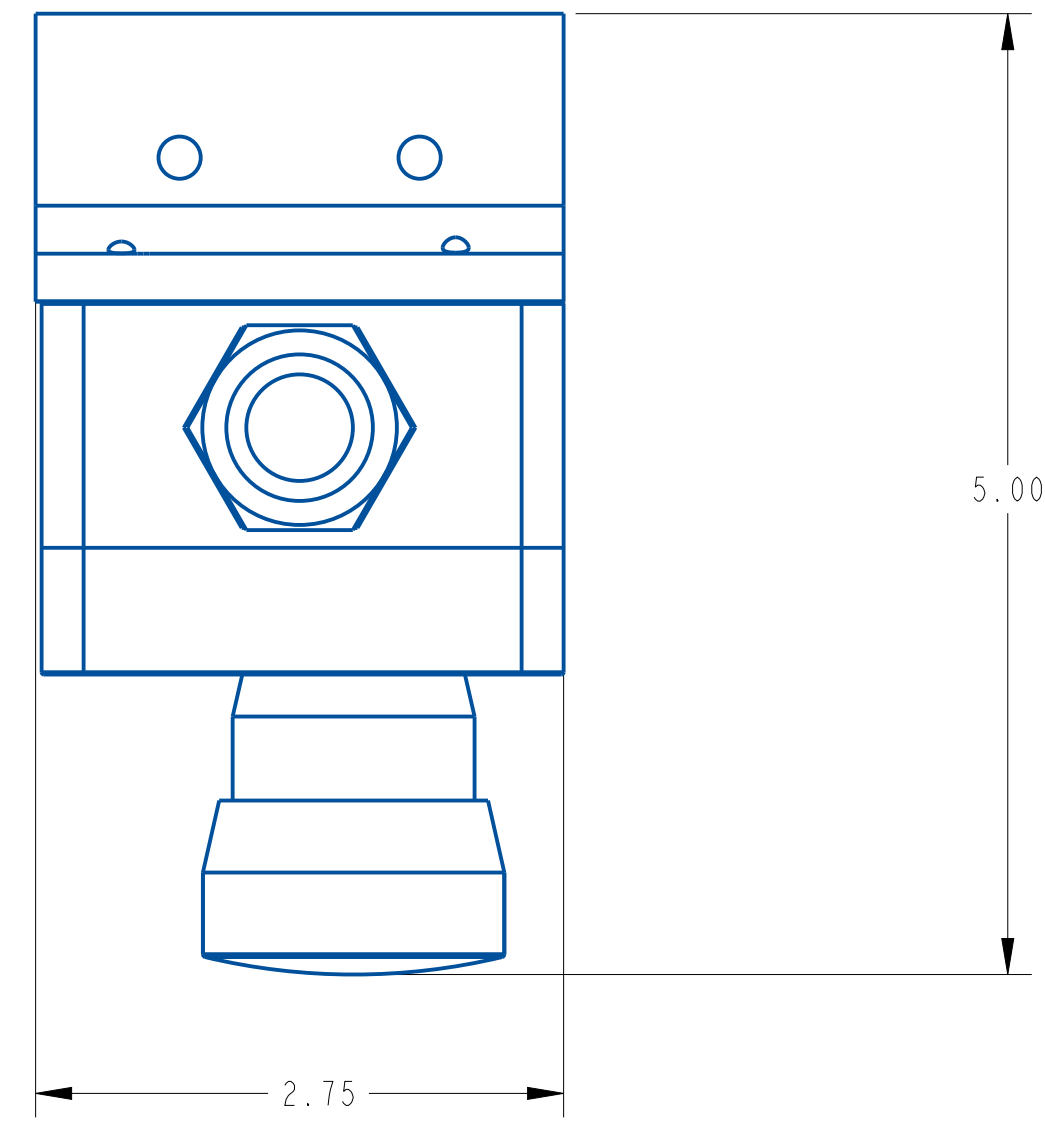

REV	DATE	DESCRIPTION	BY
A	8-29-16	NEW DRAWING	TJS

THIS IS A PRO-ENGINEER DOCUMENT AND MAY NOT BE MODIFIED MANUALLY

UNLESS OTHERWISE SPECIFIED DIMENSIONAL TOLERANCE	.XX ± .01 .XXX ± .005 ANGLES ± .30° SURFACE FINISH 125 BREAK ALL EDGES .005/ .015 CORNER RADIUS .010/ .030 ALL ANGLES ARE 90°	QUADREL LABELING SYSTEMS 7670 JENTHER DRIVE MENTOR, OHIO 44060 (440) 602-4700	SCALE: 1/1 DATE: 8-29-16 DRW BY: TJS CHK BY: 03/08/2024-SEM APPR BY:
---	---	---	--

MAT'L	EMERGENCY STOP ASSEMBLY	20789-000
-------	-------------------------	-----------

ASSEMBLY TITLE: HEAD SUPPORT ASSEMBLY

GENERAL FUNCTION:

The head support assembly keeps the labeling head in a “locked position” and prevents head vibration and wobbling as the label motor is engaged. The head support assembly is also used to set the camber or front/back tilt of the head.

SETUP AND ADJUSTMENTS:

HORIZONTAL ADJUSTMENT: To set the horizontal position of the labeling head, use the side mount wheel handle (some older systems may feature the ratcheted handle). Turn the handle clockwise to move the head towards the conveyor. Turn it counter clockwise to move the head away from the conveyor.

VERTICAL ADJUSTMENT: Using the lower wheel handle to set the vertical position of the labeling head. Turn the wheel clockwise to lower labeling head. Turn the wheel counter clockwise to raise the labeling head.

MAINTENANCE:

No scheduled maintenance is required for this assembly. Always keep the drive areas free of label flash and debris.

TROUBLESHOOTING: None this section.

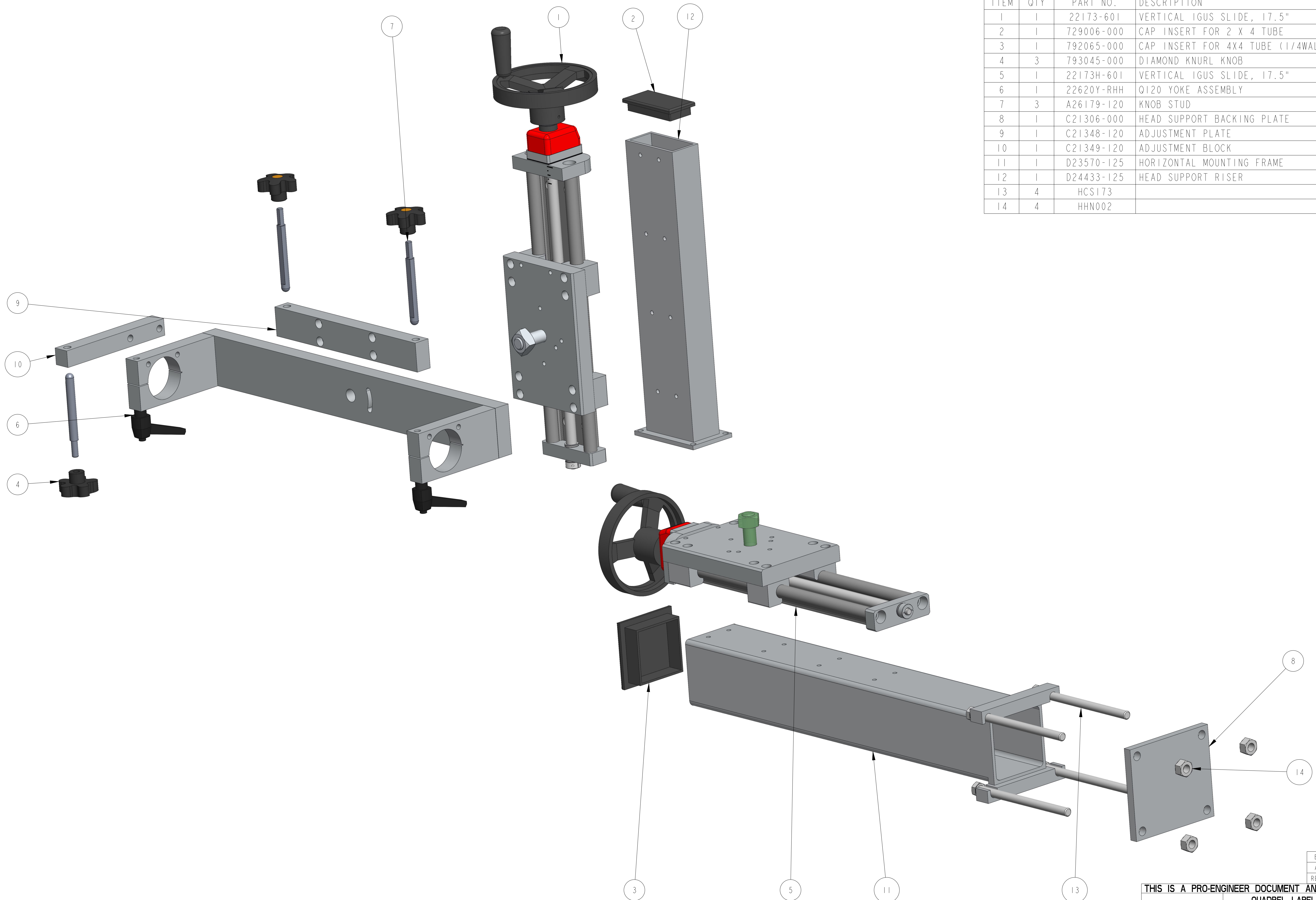

ITEM	QTY	PART NO.	DESCRIPTION	PARENT ITEM
1	1	22173-601	VERTICAL IGUS SLIDE, 17.5"	22530-220-RH
2	1	729006-000	CAP INSERT FOR 2 X 4 TUBE	22530-220-RH
3	1	792065-000	CAP INSERT FOR 4X4 TUBE (1/4WALL)	22530-220-RH
4	3	793045-000	DIAMOND KNURL KNOB	22530-220-RH
5	1	22173H-601	VERTICAL IGUS SLIDE, 17.5"	22530-220-RH
6	1	22620Y-RHH	Q120 YOKE ASSEMBLY	22530-220-RH
7	3	A26179-120	KNOB STUD	22530-220-RH
8	1	C21306-000	HEAD SUPPORT BACKING PLATE	22530-220-RH
9	1	C21348-120	ADJUSTMENT PLATE	22530-220-RH
10	1	C21349-120	ADJUSTMENT BLOCK	22530-220-RH
11	1	D23570-125	HORIZONTAL MOUNTING FRAME	22530-220-RH
12	1	D24433-125	HEAD SUPPORT RISER	22530-220-RH
13	4	HCS173		22530-220-RH
14	4	HHN002		22530-220-RH

REV	DATE	DESCRIPTION	BY
B	20-FEB-2024	UPDATE THE DRAWING AND BOM	CRT
A	OCT-27-22	NEW DRAWING	TJS

THIS IS A PRO-ENGINEER DOCUMENT AND MAY NOT BE MODIFIED MANUALLY

UNLESS OTHERWISE SPECIFIED
DIMENSIONAL TOLERANCE
X ± .1
XX ± .01
XXX ± .005
ANGLES ± .30°

SURFACE FINISH 125
BREAK ALL EDGES .005/0.15
CORNER RADIUS .010/0.30

QUADREL LABELING SYSTEMS
7670 JENTHER DRIVE
MENTOR, OHIO 44060
(440) 602-4700

SCALE: 3/8
DATE: Oct-27-22
DRW BY: TJS
CHK BY: 03/07/2024-SEM
APPR BY:

OPENLINE HEAD SUPPORT FOR Q120 W/ SIKO
MAT'L

22530-220-RH

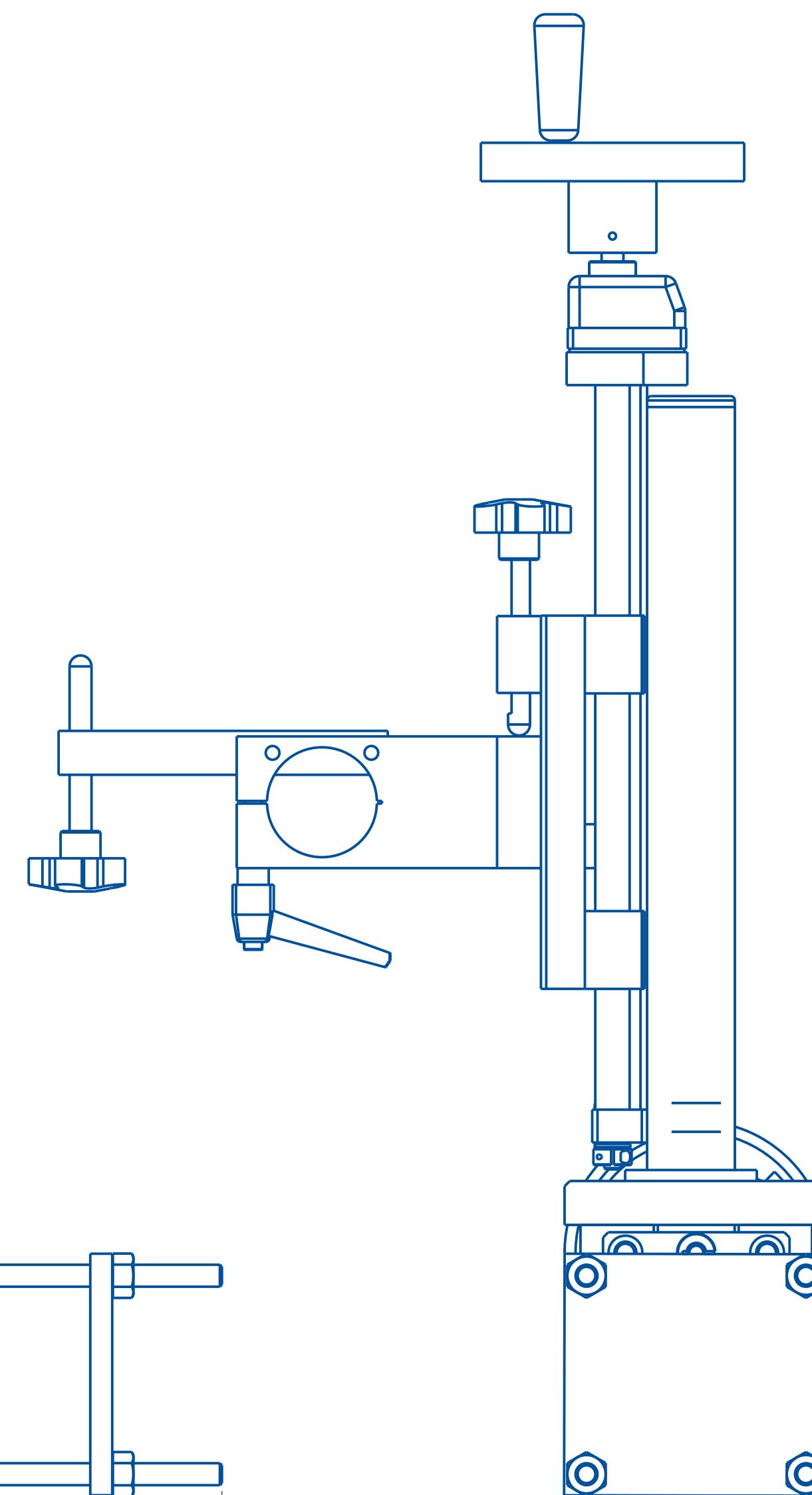
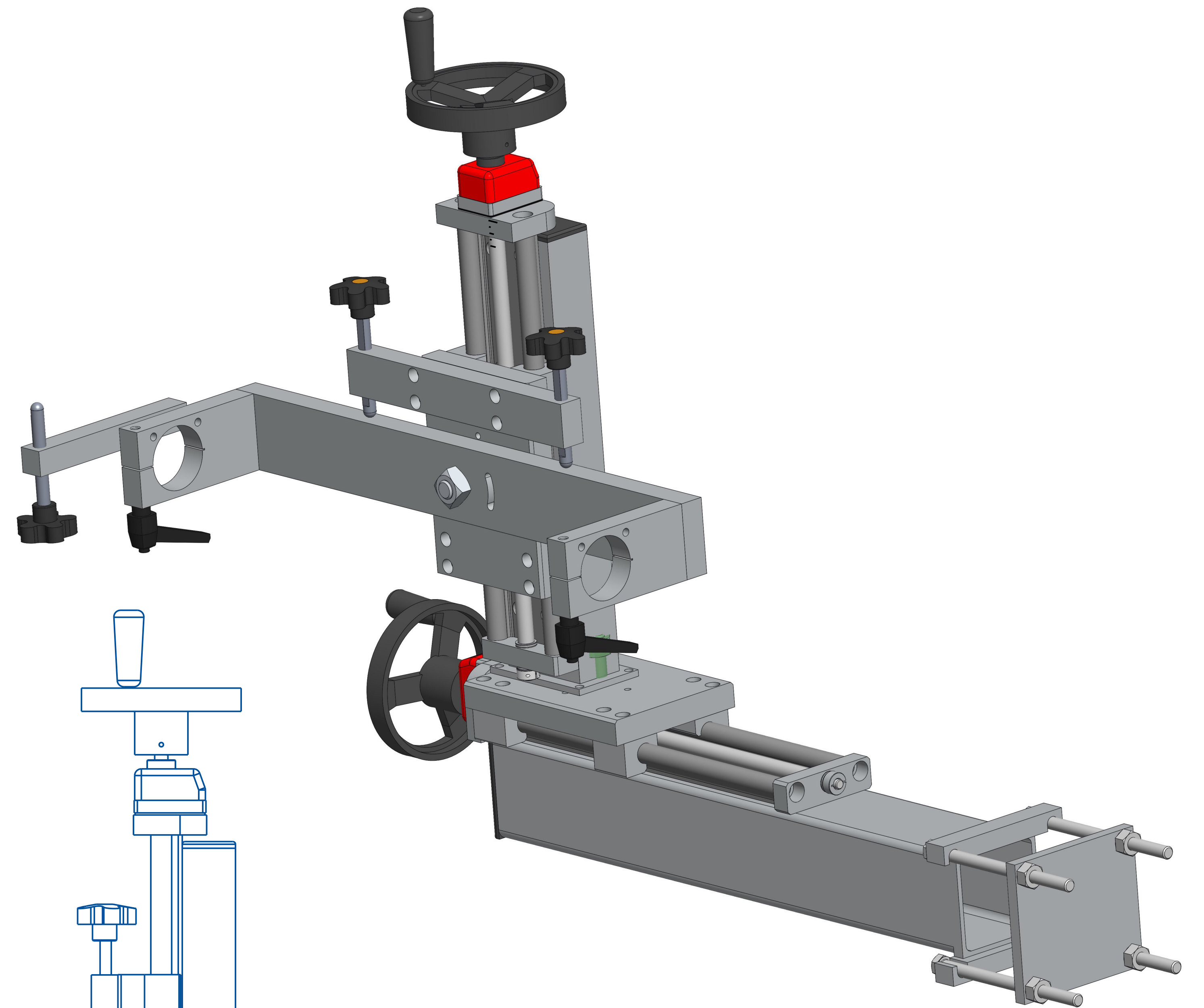
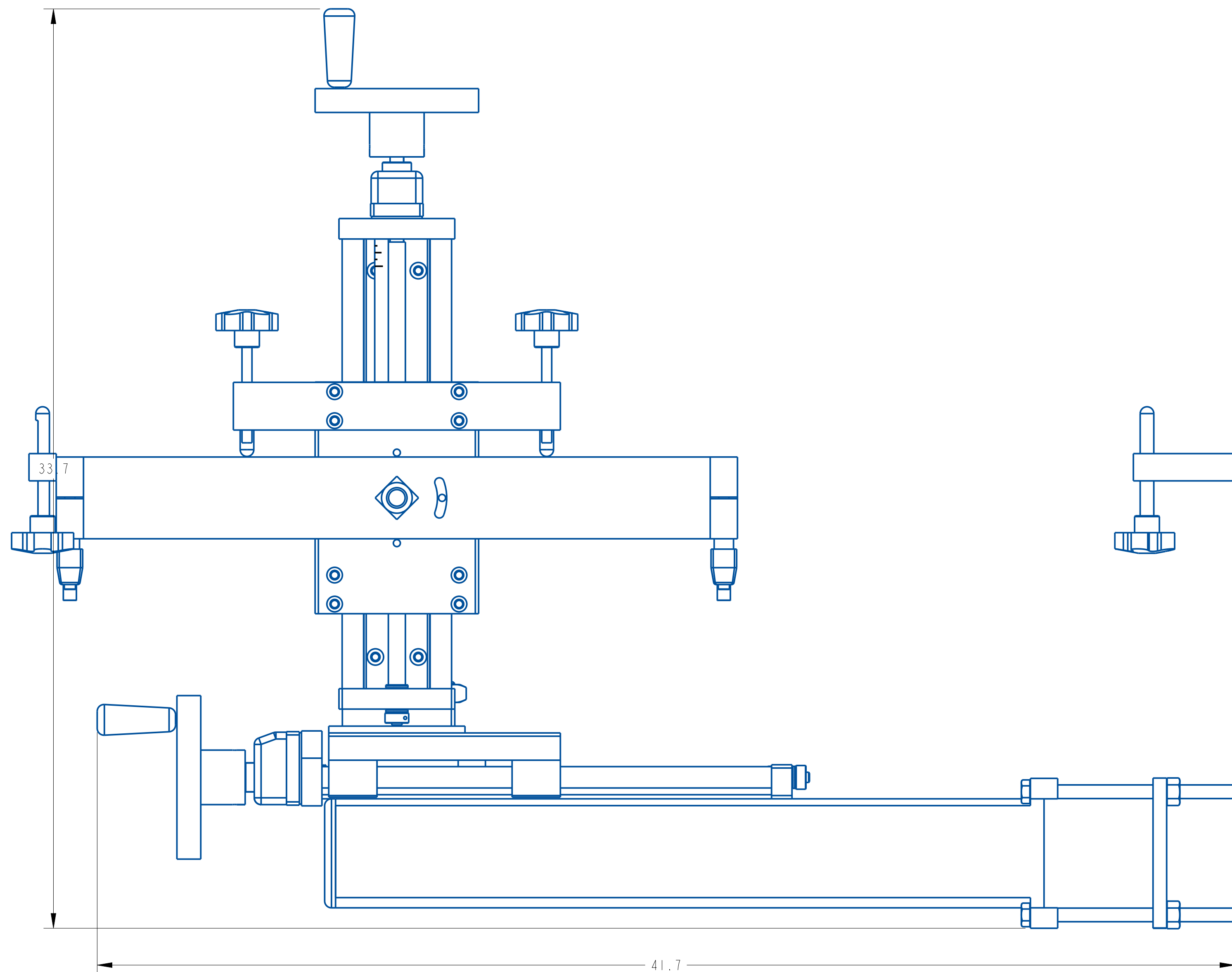
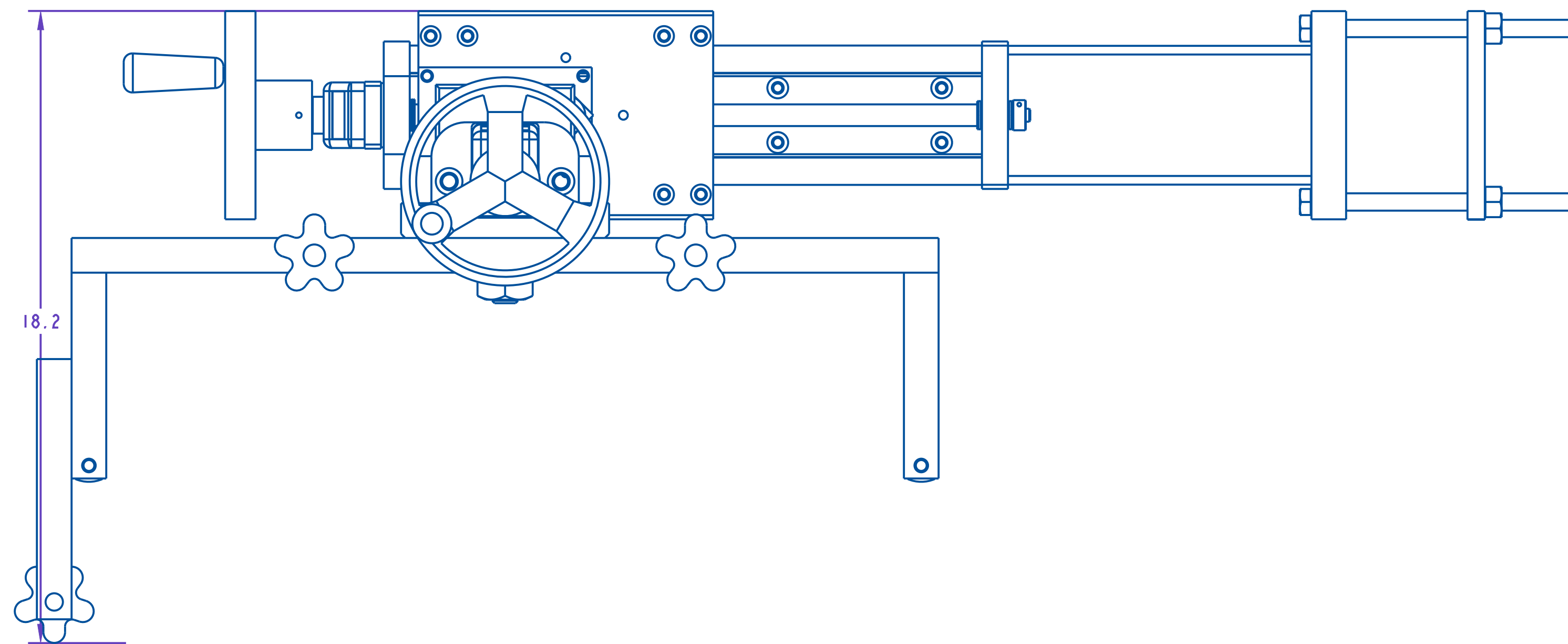

REV	DATE	DESCRIPTION	BY
A	Oct-27-22	NEW DRAWING	TJS

THIS IS A PRO-ENGINEER DOCUMENT AND MAY NOT BE MODIFIED MANUALLY

UNLESS OTHERWISE SPECIFIED
 DIMENSIONAL TOLERANCE
 X ± .1
 XX ± .01
 XXX ± .005
 ANGLES ± .30°

SURFACE FINISH 125
 BREAK ALL EDGES .005/ .015
 CORNER RADIUS .010/ .030
 ALL ANGLES ARE 90°

QUADREL LABELING SYSTEMS
 7670 JENTHER DRIVE
 MENTOR, OHIO 44060
 (440) 602-4700

SCALE: 11/32
 DATE: Oct-27-22
 DRW BY: TJS
 CHK BY: 03/07/2024-SEM
 APPR BY:

OPENLINE HEAD SUPPORT FOR Q120 W/ SIKO

MAT'L

22530-220-RH

ITEM	QTY	PART NO.	DESCRIPTION	PARENT ITEM
1	1	141172-000	SLEEVE BEARING, 1/2OD. x 3/8ID. x 3/4LNG	22173-601
2	1	141177-000	SLEEVE BEARING, 5/8OD. x 1/2ID. x 3/4LNG	22173-601
3	1	181079-000	BEARING, NEEDLE ROLLER	22173-601
4	2	181080-000	BEARING, THRUST WASHER	22173-601
5	2	181108-000	BEARING, NEEDLE ROLLER	22173-601
6	4	181111-000	THRUST WASHER	22173-601
7	1	361169-000	COLLAR, 1/2 IN. ID ONE-PIECE CLAMP	22173-601
8	1	362186-000	COLLAR, 3/8 IN. ID ONE-PIECE CLAMP	22173-601
9	1	791914-001_10	MYLAR SCALE, QUADREL LOGO	22173-601
10	4	792248-001	PILLOW BLOCK	22173-601
11	1	792354-000	DIGITAL POSITION INDICATOR	22173-601
12	1	792355-000	DRYLIN RAIL	22173-601
13	1	801080-000	HANDLE WHEEL, MODIFIED	22173-601
14	1	A24077-000	BRONZE NUT, RH	22173-601
15	1	B20045-111	THREADED ROD	22173-601
16	1	B21346-000	BOTTOM BEARING PLATE	22173-601
17	1	B22005-012	BEARING PLATE	22173-601
18	1	C20626-000	STAND SLED	22173-601
19	1	HCS281		22173-601
20	1	SN022		22173-601

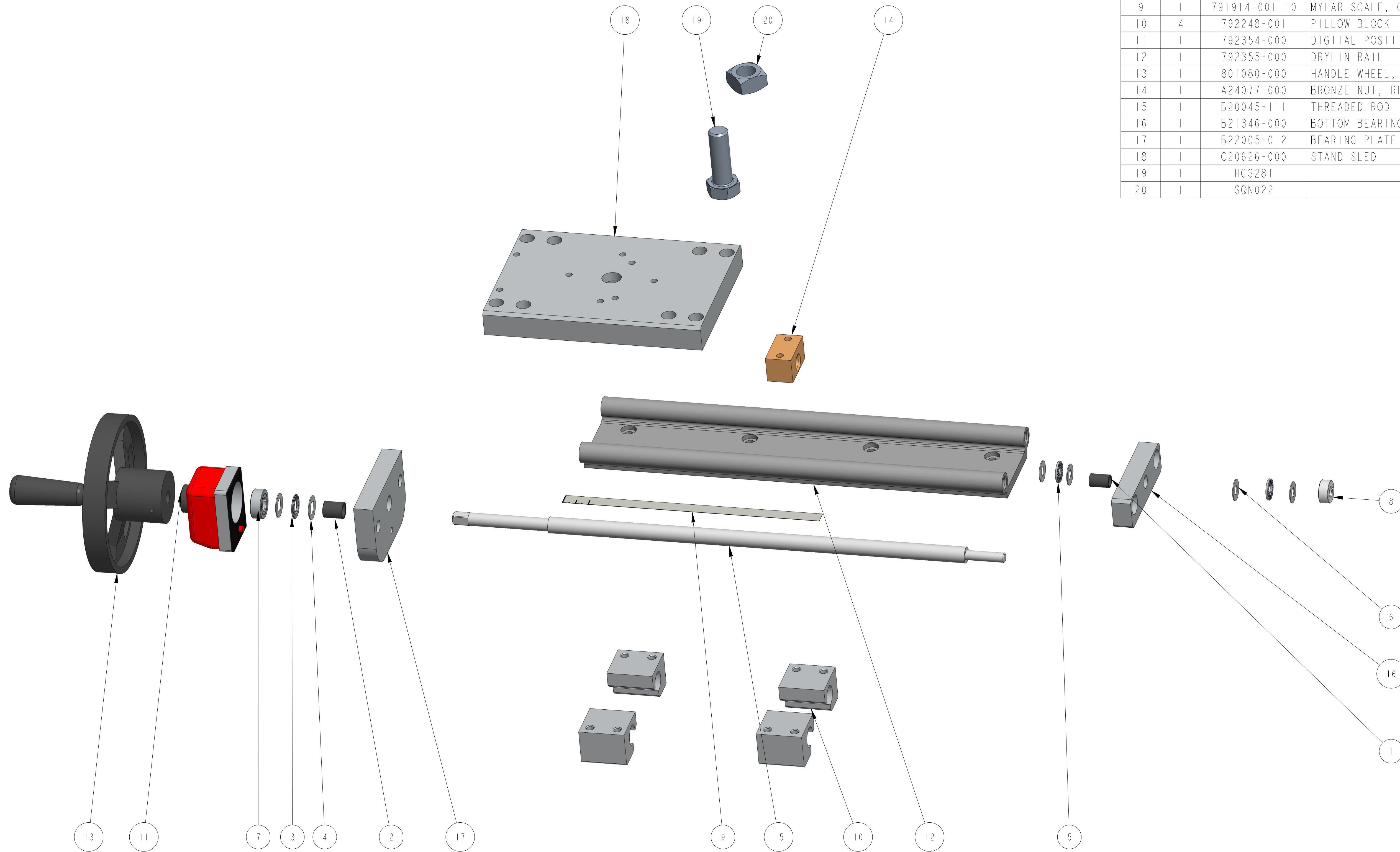

REV	DATE	DESCRIPTION	BY
A	3-25-20	NEW DRAWING	ATT

THIS IS A PRO-ENGINEER DOCUMENT AND MAY NOT BE MODIFIED MANUALLY

UNLESS OTHERWISE SPECIFIED DIMENSIONAL TOLERANCE	QUADREL LABELING SYSTEMS 7670 JENTHER DRIVE MENTOR, OHIO 44060 (440) 602-4700	SCALE: 1/2 DATE: 3-25-20 DRW BY: ATT CHK BY: 03/02/24-SEM APPR BY:
VERTICAL IGUS SLIDE, 17.5"		
MAT'L	22173-000	22173-601

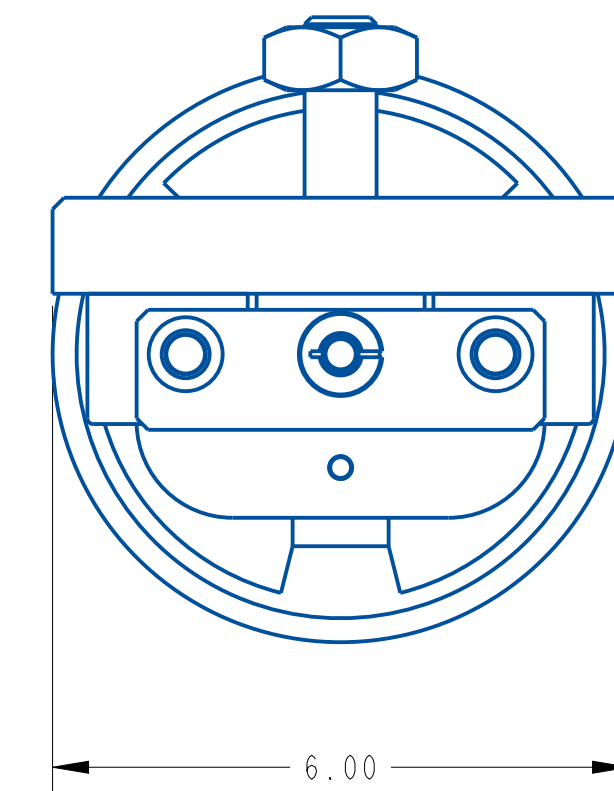
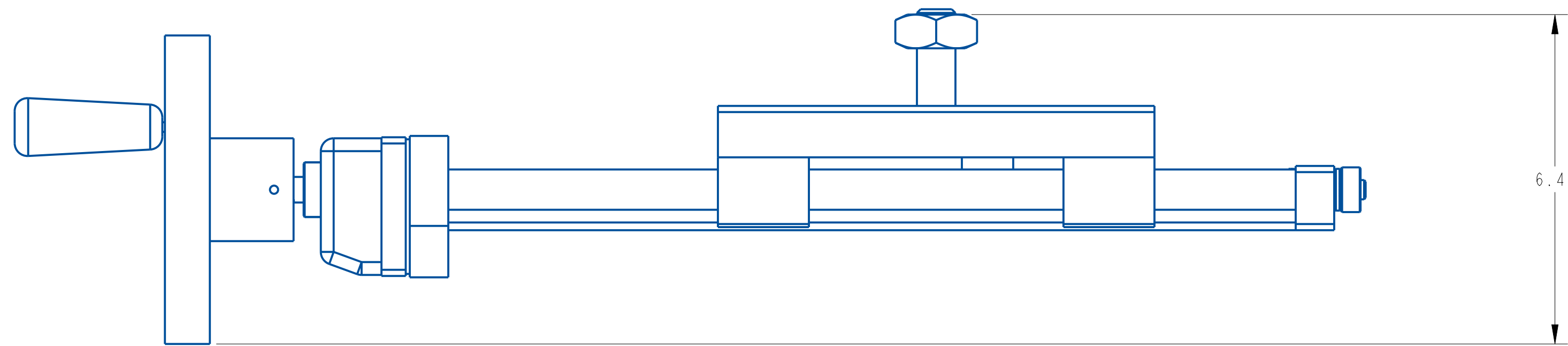
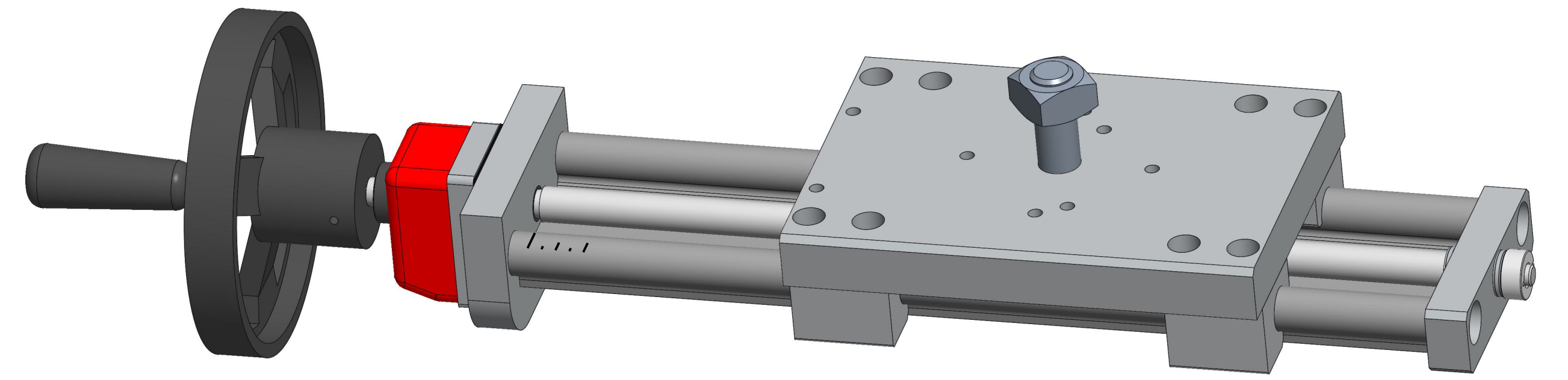
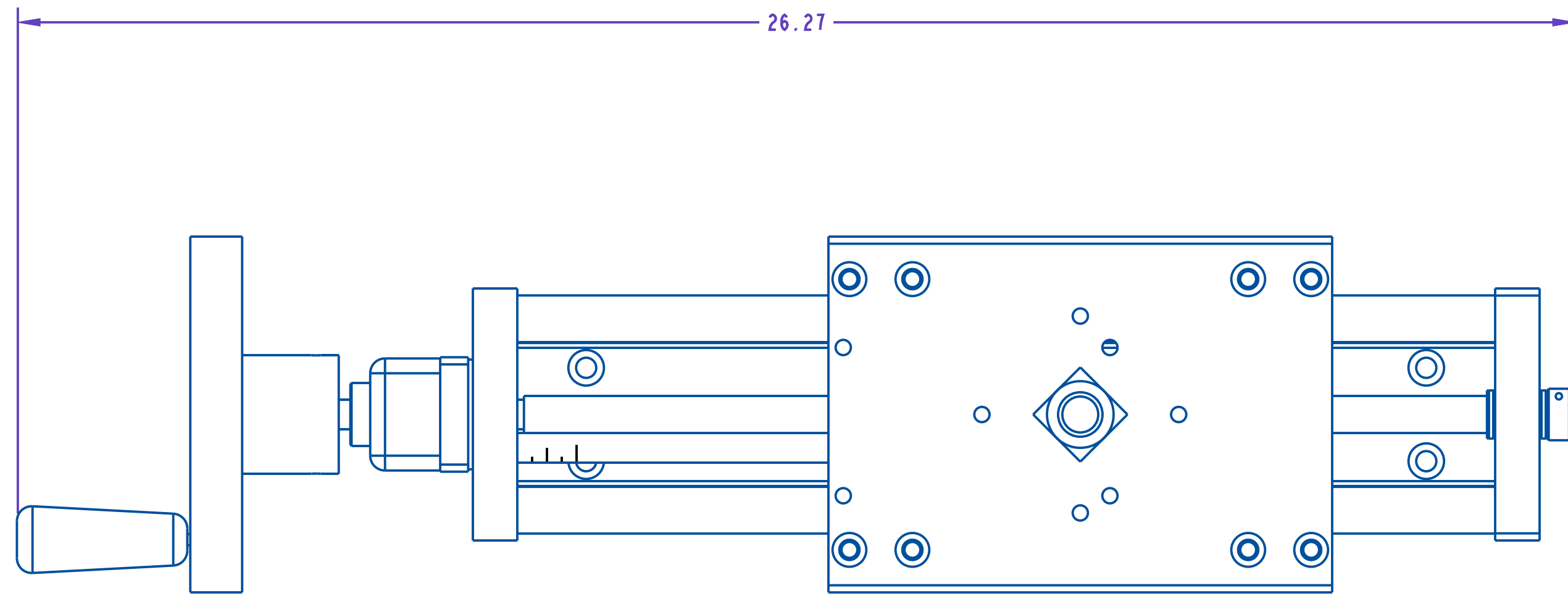

REV	DATE	DESCRIPTION	BY
A	3-25-20	NEW DRAWING	ATT

THIS IS A PRO-ENGINEER DOCUMENT AND MAY NOT BE MODIFIED MANUALLY

QUADREL LABELING SYSTEMS
 7670 JENTHER DRIVE
 MENTOR, OHIO 44060
 (440) 602-4700

SCALE: 1/2
 DATE: 3-25-20
 DRW BY: ATT
 CHK BY: 03/02/24-SEM
 APPR BY:

SURFACE FINISH: 125
 BREAK ALL EDGES: .005/0.15
 CORNER RADIUS: .010/.030
 ALL ANGLES ARE 90°

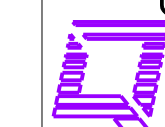

MAT'L 22173-000 22173-601

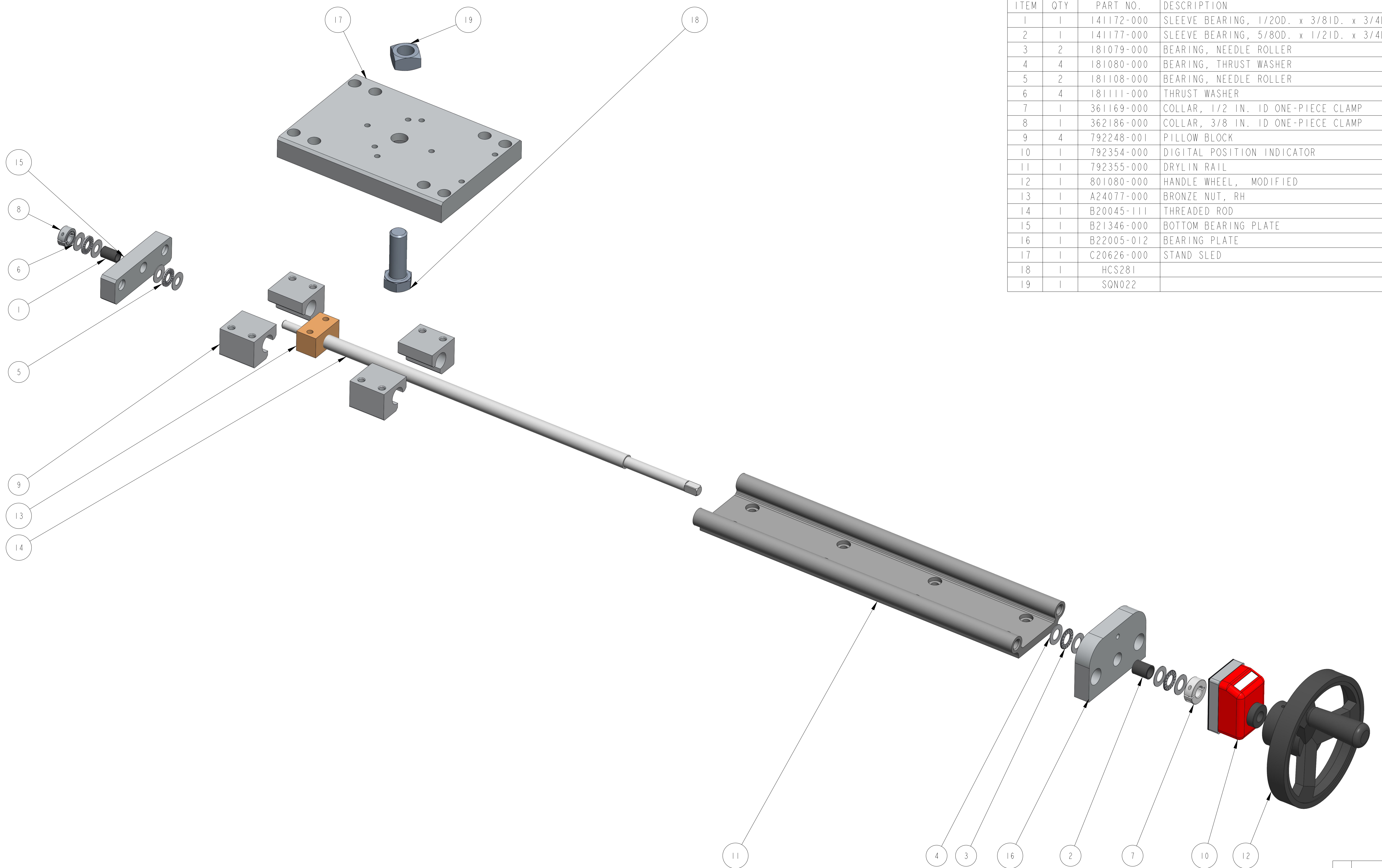

ITEM	QTY	PART NO.	DESCRIPTION	PARENT ITEM
1	1	141172-000	SLEEVE BEARING, 1/2OD. x 3/8ID. x 3/4LNG	22173H-601
2	1	141177-000	SLEEVE BEARING, 5/8OD. x 1/2ID. x 3/4LNG	22173H-601
3	2	181079-000	BEARING, NEEDLE ROLLER	22173H-601
4	4	181080-000	BEARING, THRUST WASHER	22173H-601
5	2	181108-000	BEARING, NEEDLE ROLLER	22173H-601
6	4	181111-000	THRUST WASHER	22173H-601
7	1	361169-000	COLLAR, 1/2 IN. ID ONE-PIECE CLAMP	22173H-601
8	1	362186-000	COLLAR, 3/8 IN. ID ONE-PIECE CLAMP	22173H-601
9	4	792248-001	PILLOW BLOCK	22173H-601
10	1	792354-000	DIGITAL POSITION INDICATOR	22173H-601
11	1	792355-000	DRYLIN RAIL	22173H-601
12	1	801080-000	HANDLE WHEEL, MODIFIED	22173H-601
13	1	A24077-000	BRONZE NUT, RH	22173H-601
14	1	B20045-111	THREADED ROD	22173H-601
15	1	B21346-000	BOTTOM BEARING PLATE	22173H-601
16	1	B22005-012	BEARING PLATE	22173H-601
17	1	C20626-000	STAND SLED	22173H-601
18	1	HCS281		22173H-601
19	1	SON022		22173H-601

REV	DATE	DESCRIPTION	BY
A	2-24-20	NEW DRAWING	TJS

THIS IS A PRO-ENGINEER DOCUMENT AND MAY NOT BE MODIFIED MANUALLY

UNLESS OTHERWISE SPECIFIED
 DIMENSIONAL TOLERANCE
 .XX ± .01
 .XXX ± .005
 ANGLES ± 30°

SURFACE FINISH 125
 BREAK ALL EDGES .005/0.15
 CORNER RADIUS .010/0.30

QUADREL LABELING SYSTEMS
 7670 JENTHER DRIVE
 MENTOR, OHIO 44060
 (440) 602-4700

SCALE: 1/2
 DATE: 2-24-20
 DRW BY: TJS
 CHK BY: 03/02/24-SEM
 APPR BY:

VERTICAL IGUS SLIDE, 17.5"

MAT'L 22173H-601

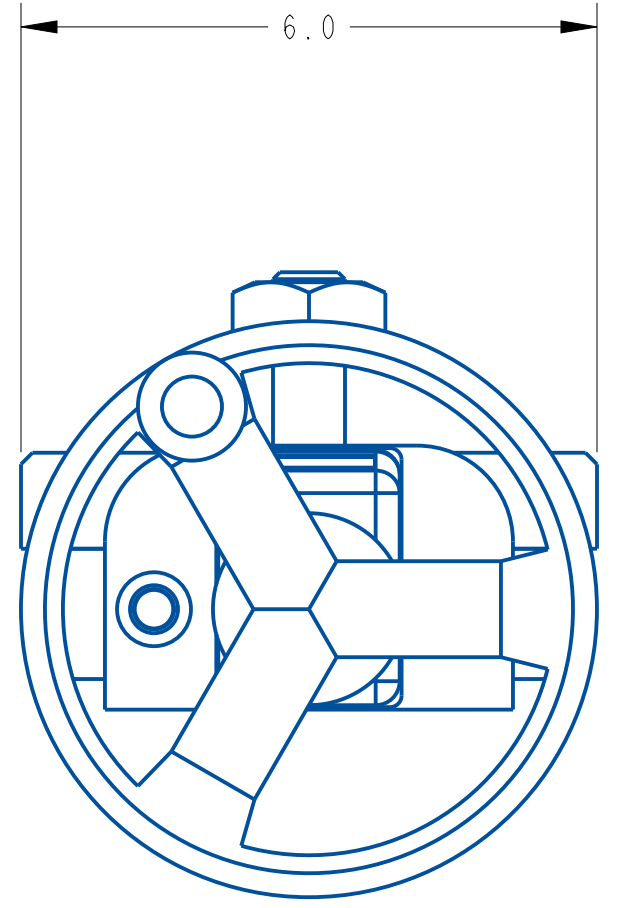
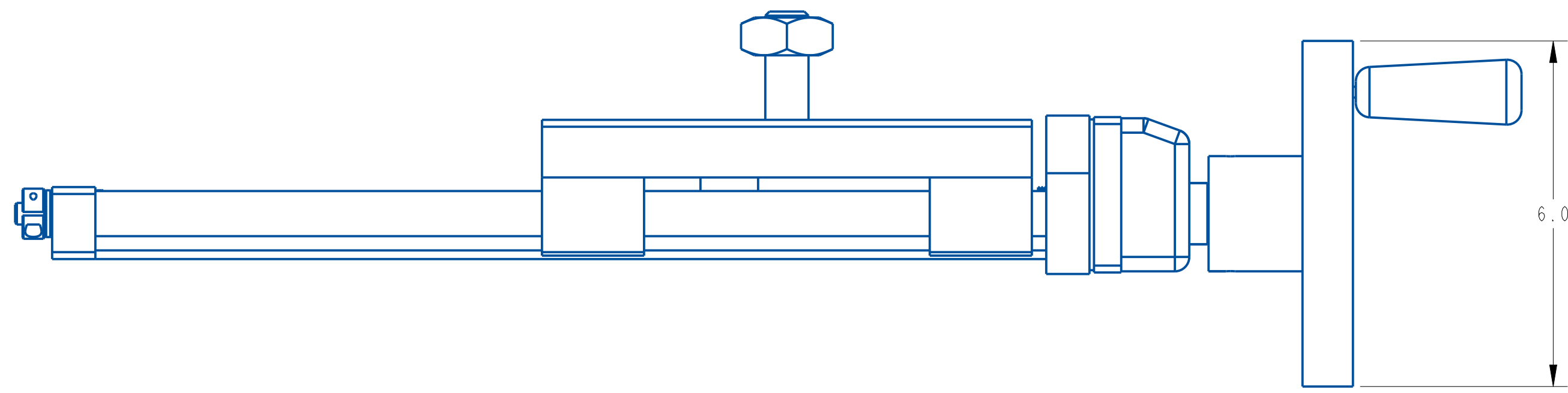
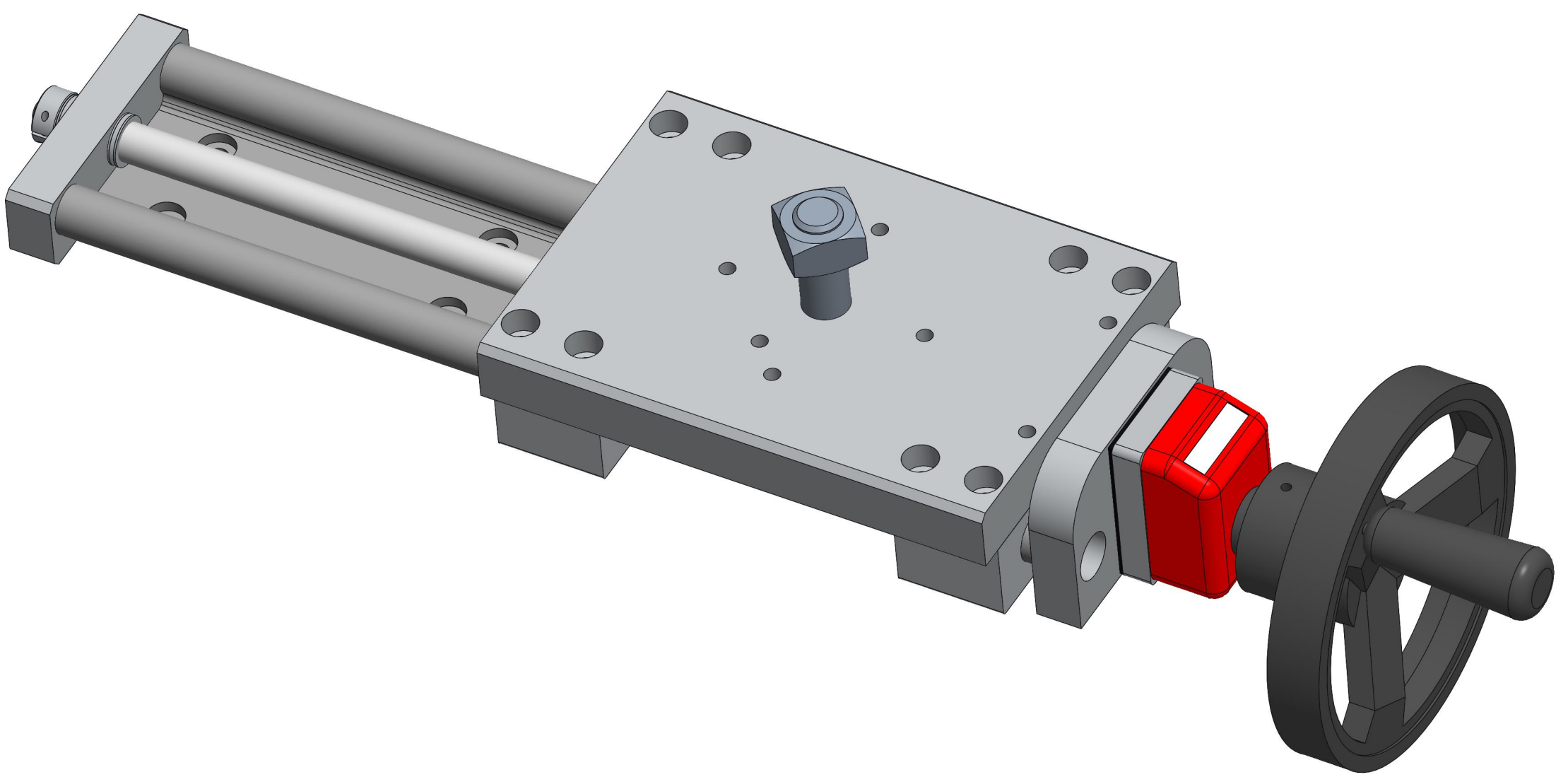
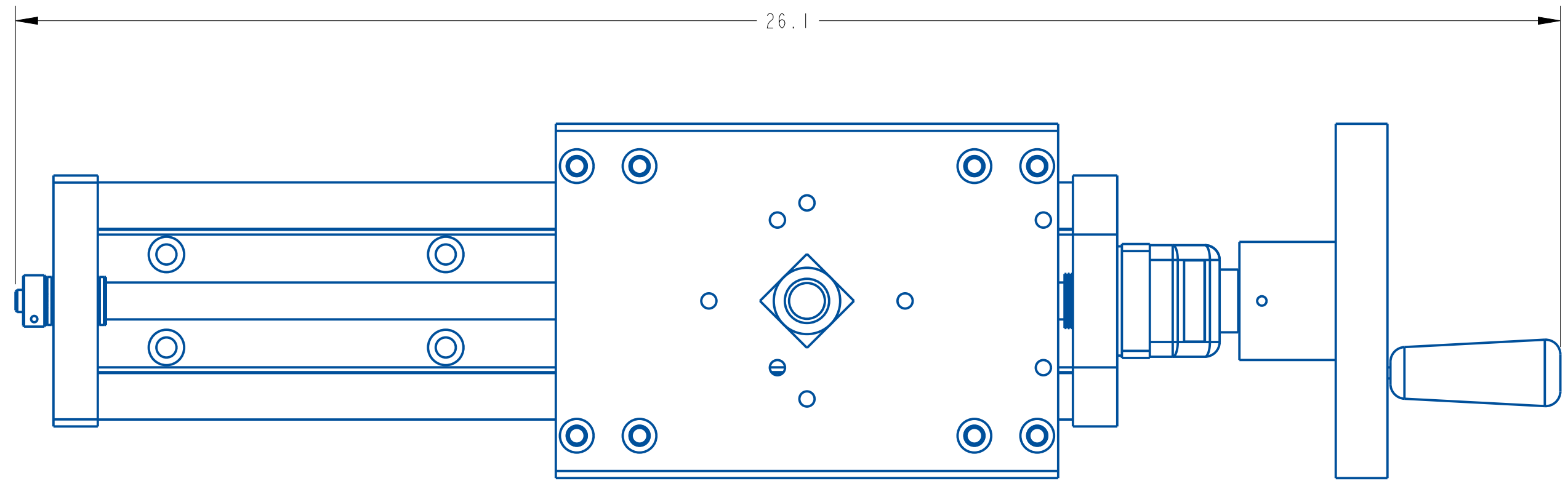

REV	DATE	DESCRIPTION	BY
A	2-24-20	NEW DRAWING	TJS

THIS IS A PRO-ENGINEER DOCUMENT AND MAY NOT BE MODIFIED MANUALLY

UNLESS OTHERWISE SPECIFIED DIMENSIONAL TOLERANCE	.XX ± .01 .XXX ± .005 ANGLES ± .30° SURFACE FINISH 125 BREAK ALL EDGES .005/ .015 CORNER RADIUS .010/ .030 ALL ANGLES ARE 90°	QUADREL LABELING SYSTEMS 7670 JENTHER DRIVE MENTOR, OHIO 44060 (440) 602-4700	SCALE: 1/2 DATE: 2-24-20 DRW BY: TJS CHK BY: 03/02/24-SEM APPR BY:
---	---	---	--

MAT'L	VERTICAL IGUS SLIDE, 17.5"	22173H-601
-------	----------------------------	------------

ITEM	QTY	PART NO.	DESCRIPTION	PARENT ITEM
1	2	801850-000	CLAMPING LEVER	22620Y-RHH
2	2	B21190-114	YOKE SIDE PLATE	22620Y-RHH
3	1	B21555-000	MTG YOKE BACK PLATE	22620Y-RHH

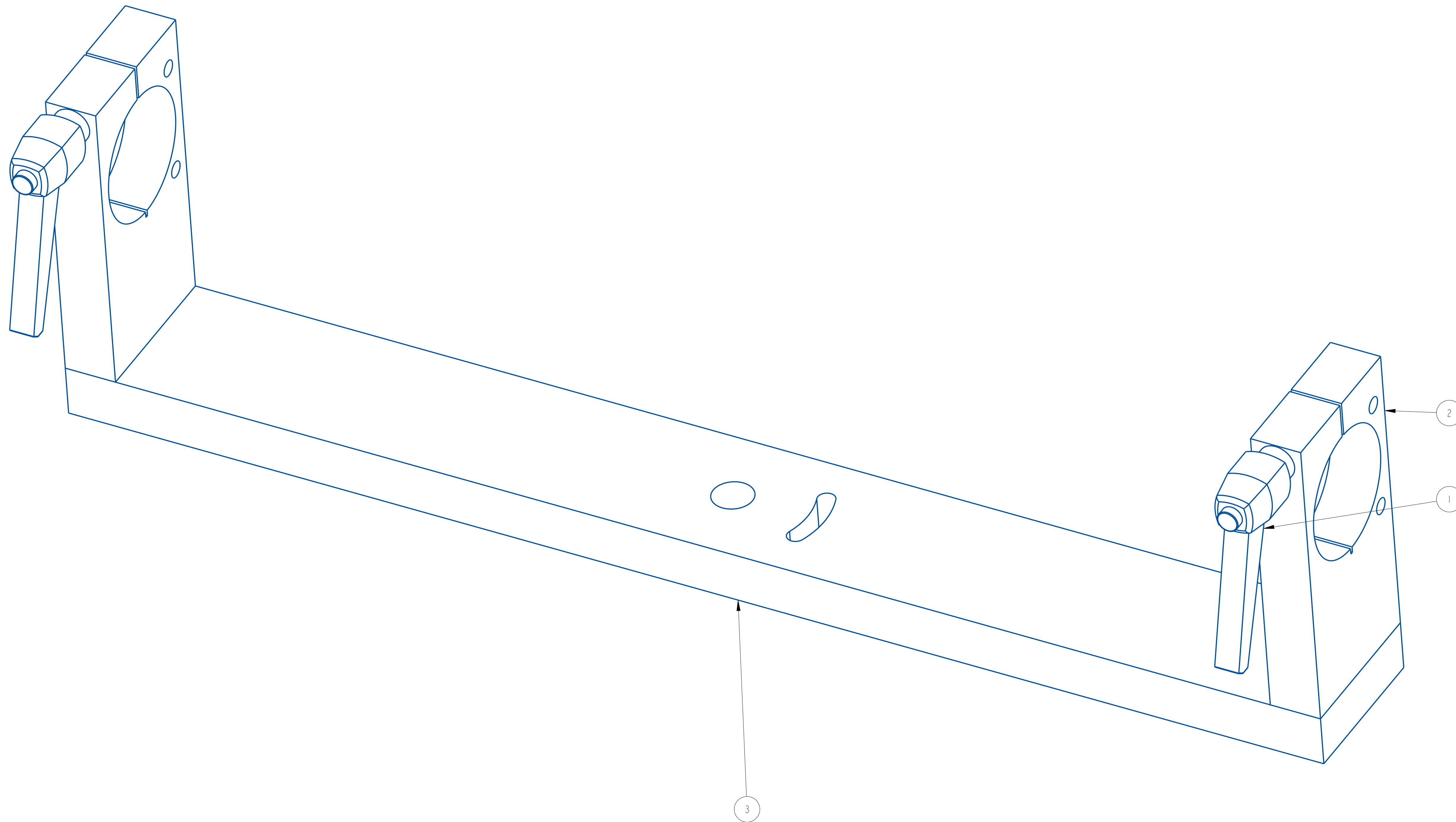

REV	DATE	DESCRIPTION	BY
A	11-26-13	NEW DRAWING	ATT

THIS IS A PRO-ENGINEER DOCUMENT AND MAY NOT BE MODIFIED MANUALLY

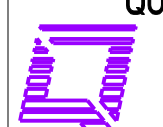
UNLESS OTHERWISE SPECIFIED DIMENSIONAL TOLERANCE .X ± .1 .XX ± .01 .XXX ± .005 ANGLES ± 30°	 7670 JENTHER DRIVE MENTOR, OHIO 44060 (440) 602-4700	SCALE: 1/1
		DATE: 11-26-13
		DRW BY: ATT
		CHK BY: 03/07/2024-SEM
Q120 YOKE ASSEMBLY		MAT'L
		22620Y-RHH

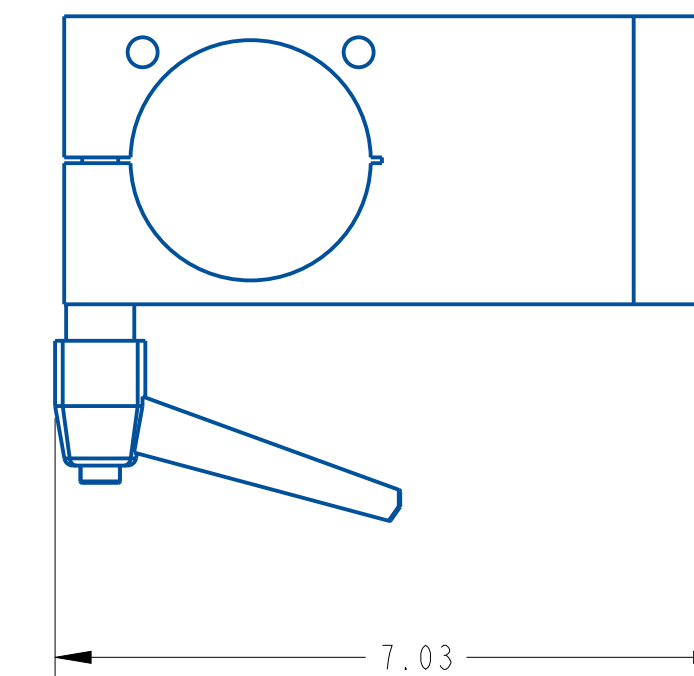
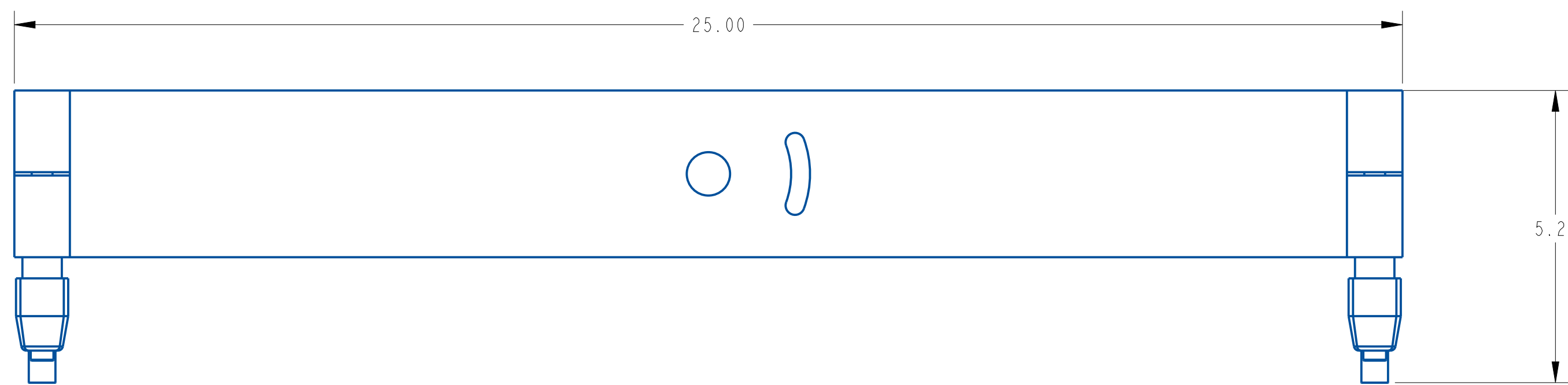
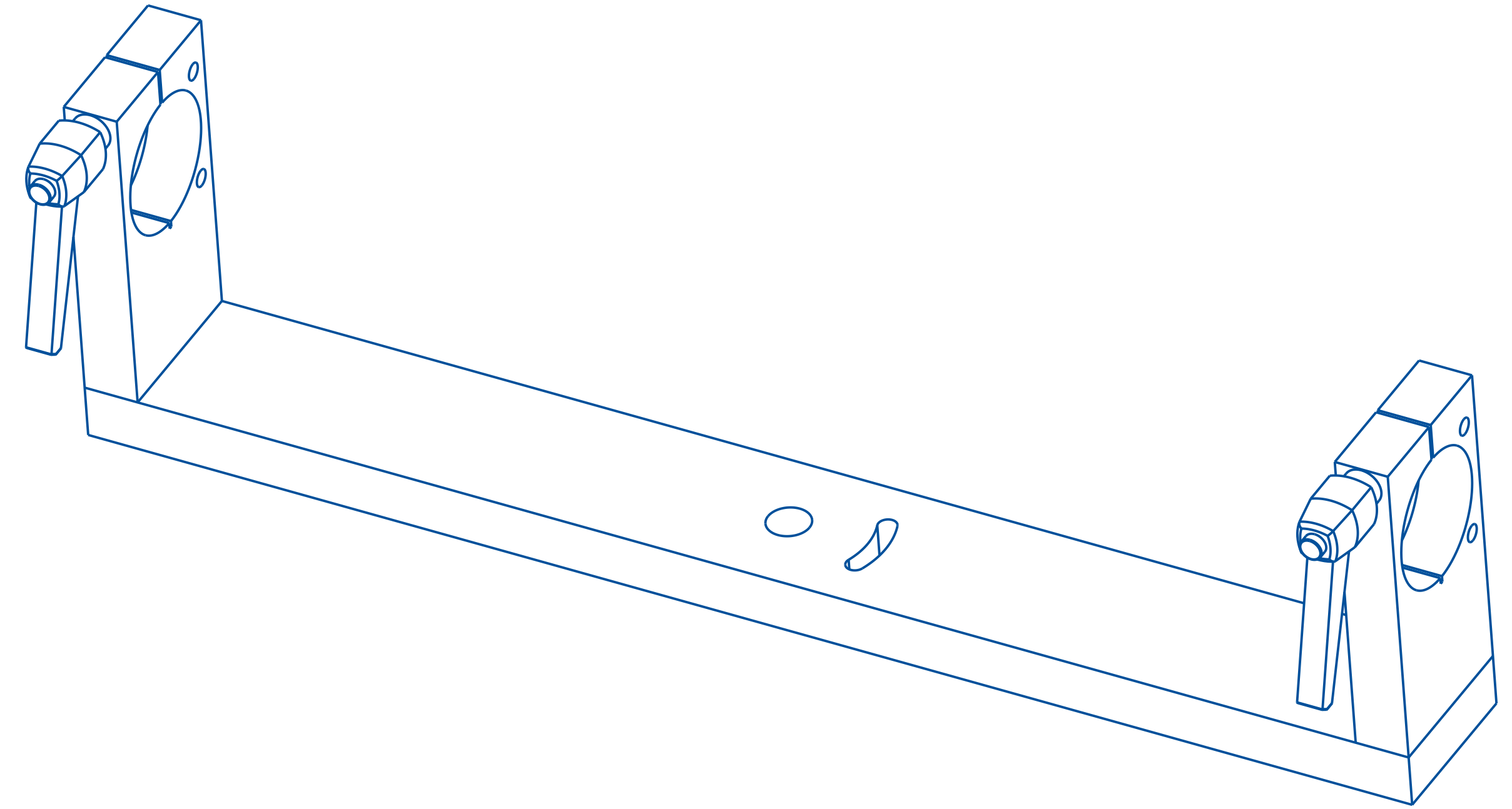
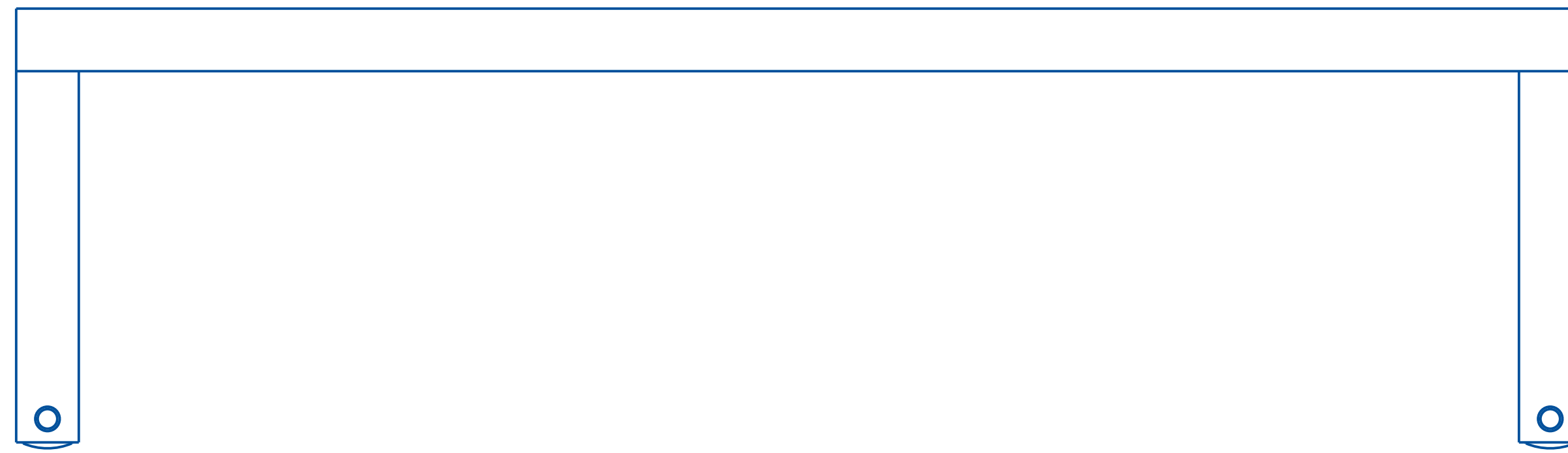

REV	DATE	DESCRIPTION	BY
A	11-26-13	NEW DRAWING	ATT

THIS IS A PRO-ENGINEER DOCUMENT AND MAY NOT BE MODIFIED MANUALLY

UNLESS OTHERWISE SPECIFIED
DIMENSIONAL TOLERANCE
X ± .1
XX ± .01
XXX ± .005
ANGLES ± .30°
SURFACE FINISH 125
BREAK ALL EDGES .005/ .015
CORNER RADIUS .010/ .030
ALL ANGLES ARE 90°

QUADREL LABELING SYSTEMS
7670 JENTHER DRIVE
MENTOR, OHIO 44060
(440) 602-4700
SCALE: 1/2
DATE: 11-26-13
DRW BY: ATT
CHK BY: 03/07/2024-SEM
APPR BY:
Q120 YOKE ASSEMBLY
MATERIAL 22620Y-RHH

ASSEMBLY TITLE: HEAD SUPPORT ASSEMBLY

GENERAL FUNCTION:

The head support assembly keeps the labeling head in a “locked position” and prevents head vibration and wobbling as the label motor is engaged. The head support assembly is also used to set the camber or front/back tilt of the head.

SETUP AND ADJUSTMENTS:

HORIZONTAL ADJUSTMENT: To set the horizontal position of the labeling head, use the side mount wheel handle (some older systems may feature the ratcheted handle). Turn the handle clockwise to move the head towards the conveyor. Turn it counter clockwise to move the head away from the conveyor.

VERTICAL ADJUSTMENT: Using the lower wheel handle to set the vertical position of the labeling head. Turn the wheel clockwise to lower labeling head. Turn the wheel counter clockwise to raise the labeling head.

MAINTENANCE:

No scheduled maintenance is required for this assembly. Always keep the drive areas free of label flash and debris.

TROUBLESHOOTING: None this section.

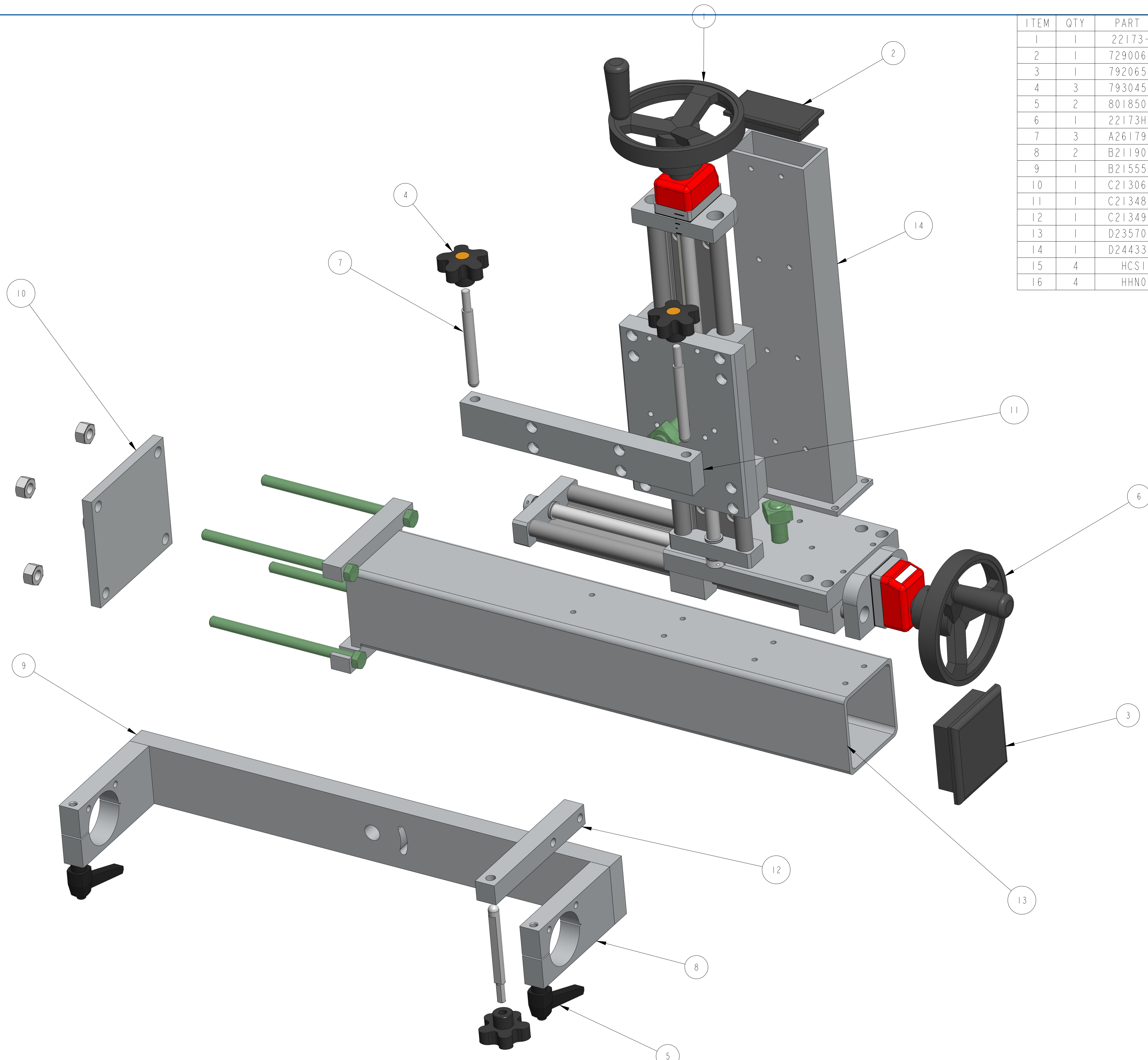

ITEM	QTY	PART NO.	DESCRIPTION	PARENT ITEM
1	1	22173-601	VERTICAL IGUS SLIDE, 17.5"	22530-220-LH
2	1	729006-000	CAP INSERT FOR 2 X 4 TUBE	22530-220-LH
3	1	792065-000	CAP INSERT FOR 4X4 TUBE (1/4WALL)	22530-220-LH
4	3	793045-000	DIAMOND KNURL KNOB	22530-220-LH
5	2	801850-000	CLAMPING LEVER	22530-220-LH
6	1	22173H-601	VERTICAL IGUS SLIDE, 17.5"	22530-220-LH
7	3	A26179-120	KNOB STUD	22530-220-LH
8	2	B21190-114	YOKE SIDE PLATE	22530-220-LH
9	1	B21555-000	MTG YOKE BACK PLATE	22530-220-LH
10	1	C21306-000	HEAD SUPPORT BACKING PLATE	22530-220-LH
11	1	C21348-120	ADJUSTMENT PLATE	22530-220-LH
12	1	C21349-120	ADJUSTMENT BLOCK	22530-220-LH
13	1	D23570-125	HORIZONTAL MOUNTING FRAME	22530-220-LH
14	1	D24433-125	HEAD SUPPORT RISER	22530-220-LH
15	4	HCS173		22530-220-LH
16	4	HHN002		22530-220-LH

REV	DATE	DESCRIPTION	BY
B	20-FEB-2024	UPDATED THE DRAWING AND BOM	CRT
A	OCT-27-22	NEW DRAWING	TJS

THIS IS A PRO-ENGINEER DOCUMENT AND MAY NOT BE MODIFIED MANUALLY

UNLESS OTHERWISE SPECIFIED
 DIMENSIONAL TOLERANCE
 X ± .1
 XX ± .01
 XXX ± .005
 ANGLES ± 30°

SURFACE FINISH 125
 BREAK ALL EDGES .005/ .015
 CORNER RADIUS .010/ .030

SCALE: 7/16
 DATE: OCT-27-22
 DRW BY: TJS
 CHK BY: 03/02/24-SEM
 APPR BY:

QUADREL LABELING SYSTEMS
 7670 JENTHER DRIVE
 MENTOR, OHIO 44060
 (440) 602-4700

OPENLINE HEAD SUPPORT FOR Q120 W/ SIKO

MAT'L 22530-220-LH 22530-220-LH

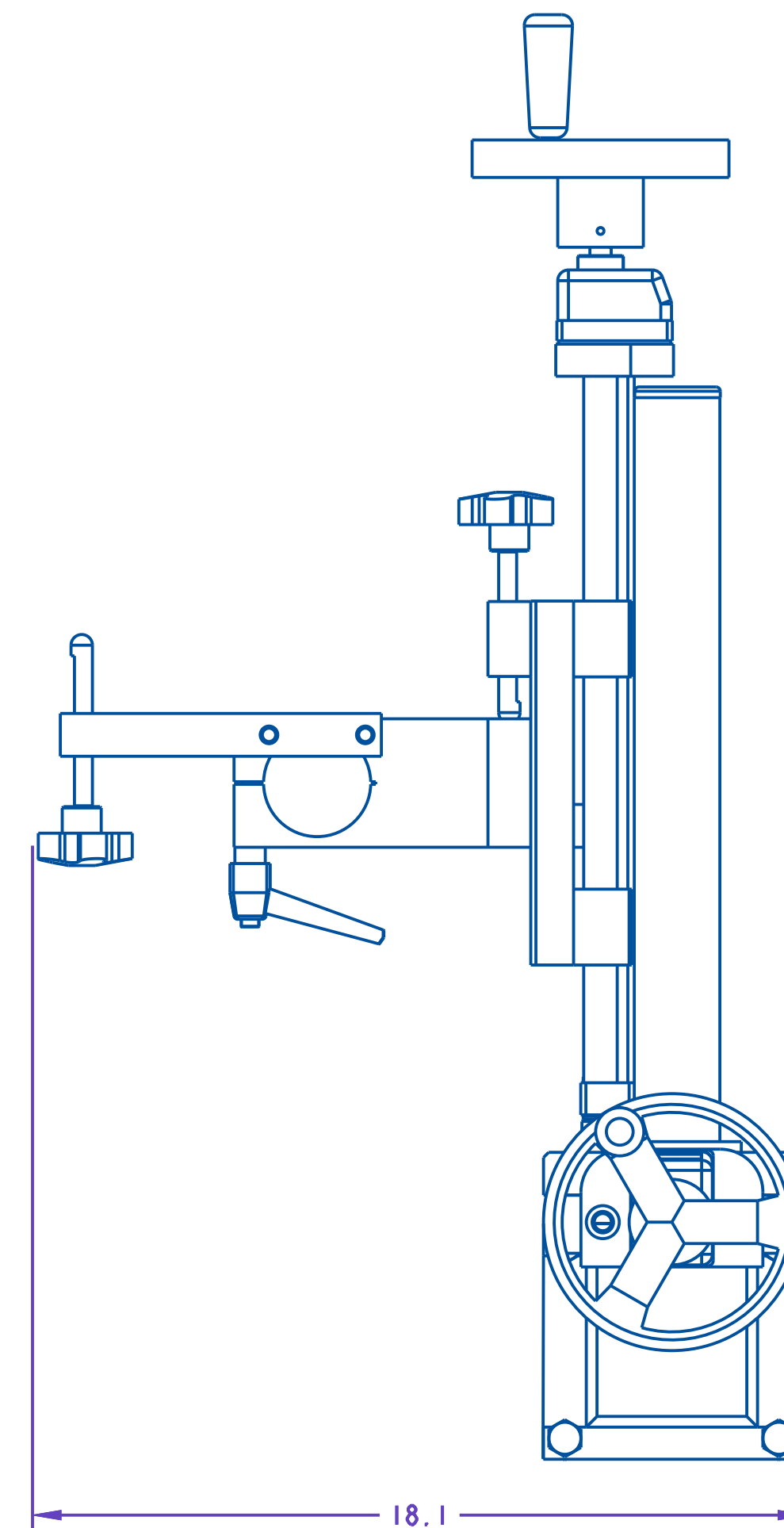
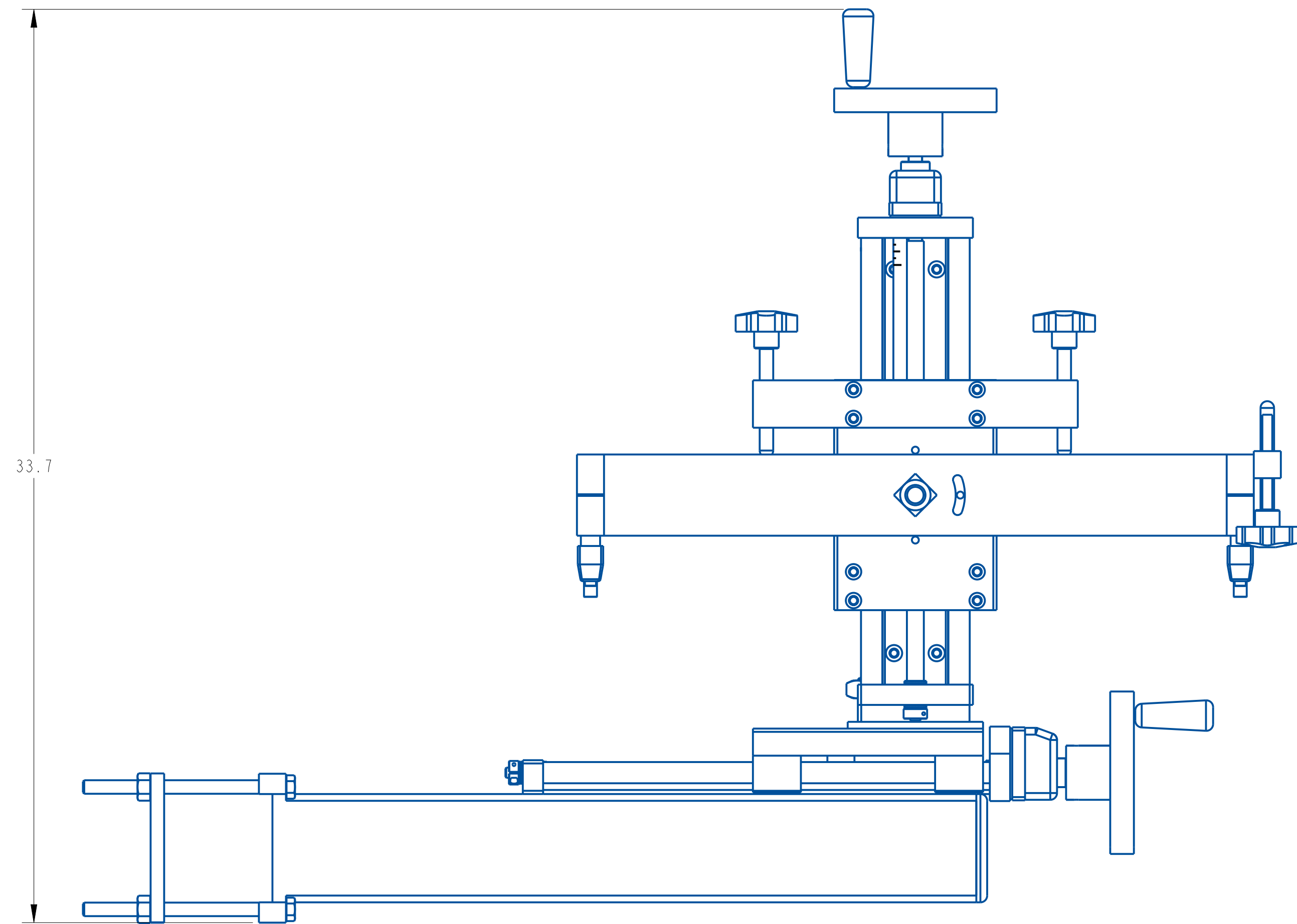
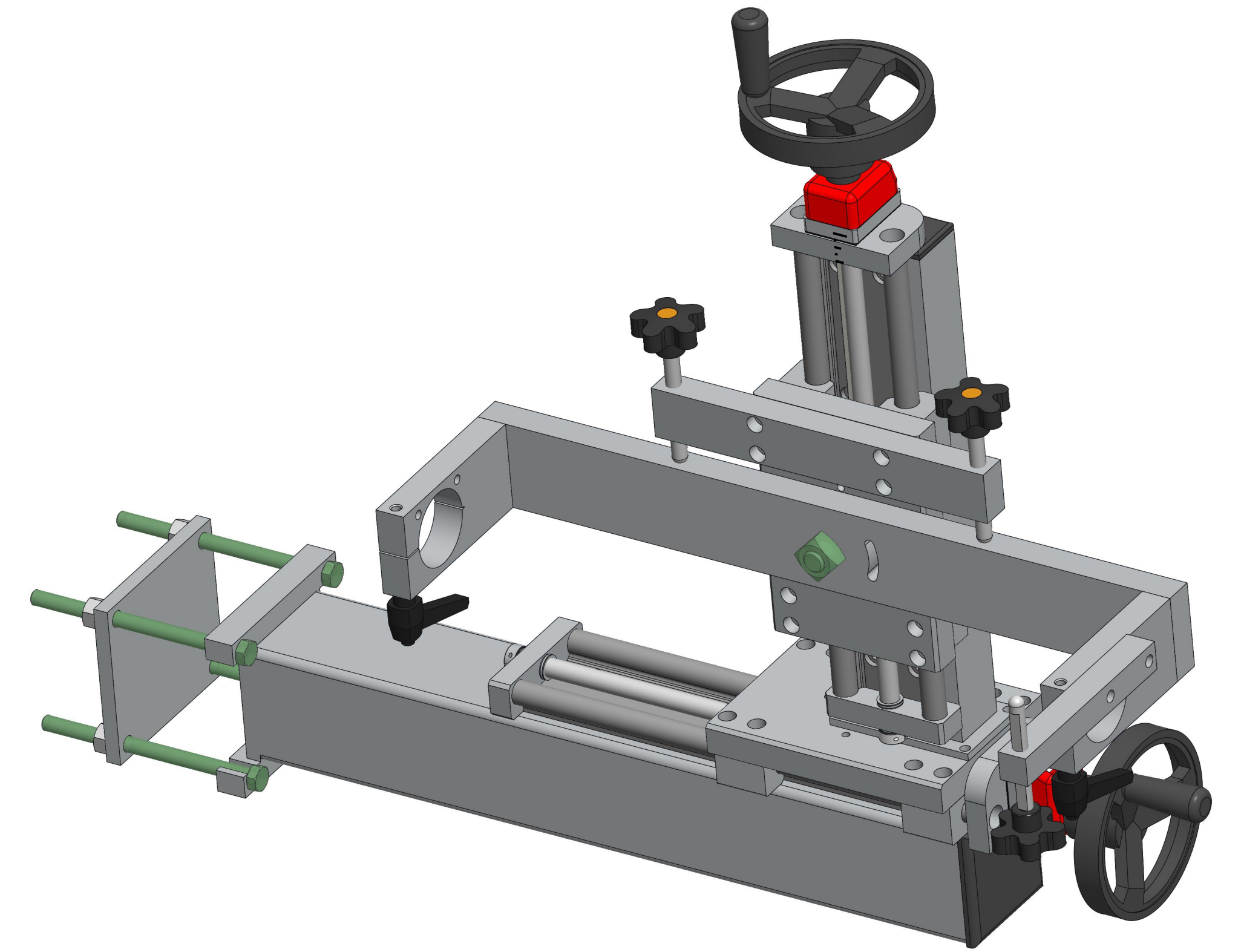
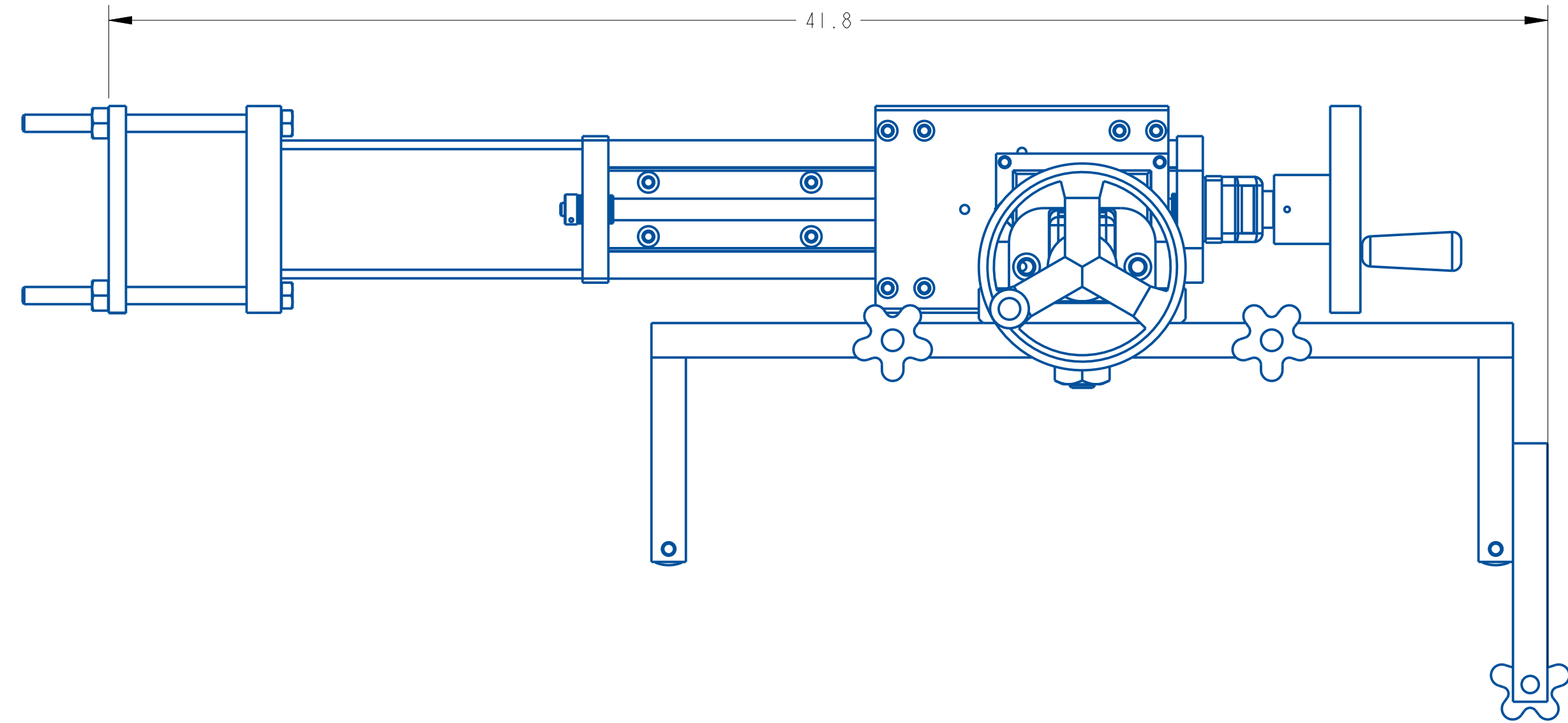

B	20-FEB-2024	UPDATE THE DRAWING AND BOM	CRT
A	OCT-27-22	NEW DRAWING	TJS
REV	DATE	DESCRIPTION	BY

THIS IS A PRO-ENGINEER DOCUMENT AND MAY NOT BE MODIFIED MANUALLY

UNLESS OTHERWISE SPECIFIED DIMENSIONAL TOLERANCE .X ± .1 .XX ± .01 .XXX ± .005 ANGLES ± .30° SURFACE FINISH 125 BREAK ALL EDGES .005/.015 CORNER RADIUS .010/.030	QUADREL LABELING SYSTEMS 7670 JENTHER DRIVE MENTOR, OHIO 44060 (440) 602-4700	SCALE: 9/32 DATE: OCT-27-22 DRW BY: TJS CHK BY: 03/02/24-SEM APPR BY:
	OPENLINE HEAD SUPPORT FOR Q120 W/ SIKO	
MAT'L	22530-220-LH	22530-220-LH

ITEM	QTY	PART NO.	DESCRIPTION	PARENT ITEM
1	1	141172-000	SLEEVE BEARING, 1/2OD. x 3/8ID. x 3/4LNG	22173-601
2	1	141177-000	SLEEVE BEARING, 5/8OD. x 1/2ID. x 3/4LNG	22173-601
3	1	181079-000	BEARING, NEEDLE ROLLER	22173-601
4	2	181080-000	BEARING, THRUST WASHER	22173-601
5	2	181108-000	BEARING, NEEDLE ROLLER	22173-601
6	4	181111-000	THRUST WASHER	22173-601
7	1	361169-000	COLLAR, 1/2 IN. ID ONE-PIECE CLAMP	22173-601
8	1	362186-000	COLLAR, 3/8 IN. ID ONE-PIECE CLAMP	22173-601
9	1	791914-001_10	MYLAR SCALE, QUADREL LOGO	22173-601
10	4	792248-001	PILLOW BLOCK	22173-601
11	1	792354-000	DIGITAL POSITION INDICATOR	22173-601
12	1	792355-000	DRYLIN RAIL	22173-601
13	1	801080-000	HANDLE WHEEL, MODIFIED	22173-601
14	1	A24077-000	BRONZE NUT, RH	22173-601
15	1	B20045-111	THREADED ROD	22173-601
16	1	B21346-000	BOTTOM BEARING PLATE	22173-601
17	1	B22005-012	BEARING PLATE	22173-601
18	1	C20626-000	STAND SLED	22173-601
19	1	HCS281		22173-601
20	1	SN022		22173-601

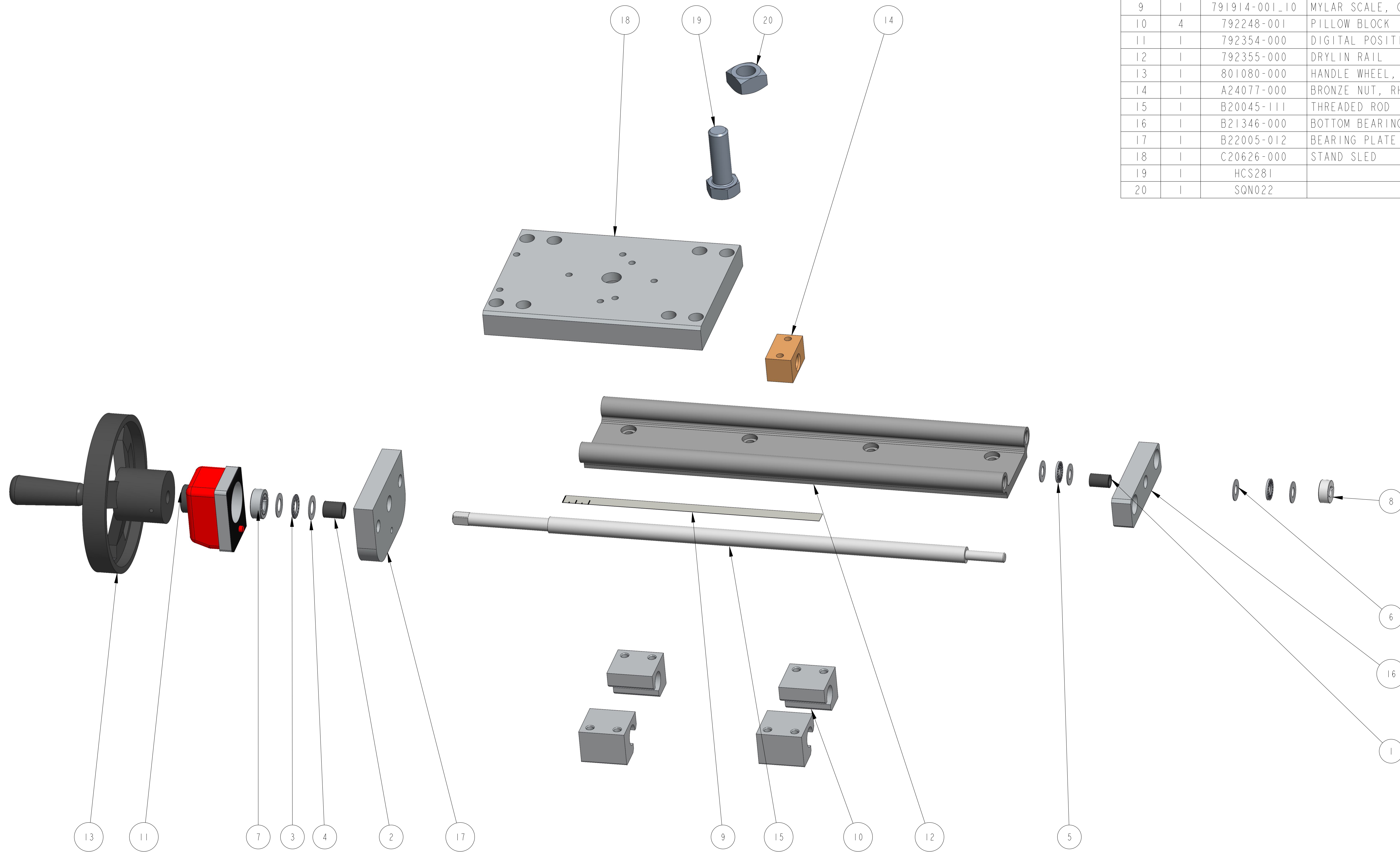

REV	DATE	DESCRIPTION	BY
A	3-25-20	NEW DRAWING	ATT

THIS IS A PRO-ENGINEER DOCUMENT AND MAY NOT BE MODIFIED MANUALLY

UNLESS OTHERWISE SPECIFIED DIMENSIONAL TOLERANCE	QUADREL LABELING SYSTEMS 7670 JENTHER DRIVE MENTOR, OHIO 44060 (440) 602-4700	SCALE: 1/2 DATE: 3-25-20 DRW BY: ATT CHK BY: 03/02/24-SEM APPR BY:
VERTICAL IGUS SLIDE, 17.5"		
MAT'L	22173-000	22173-601

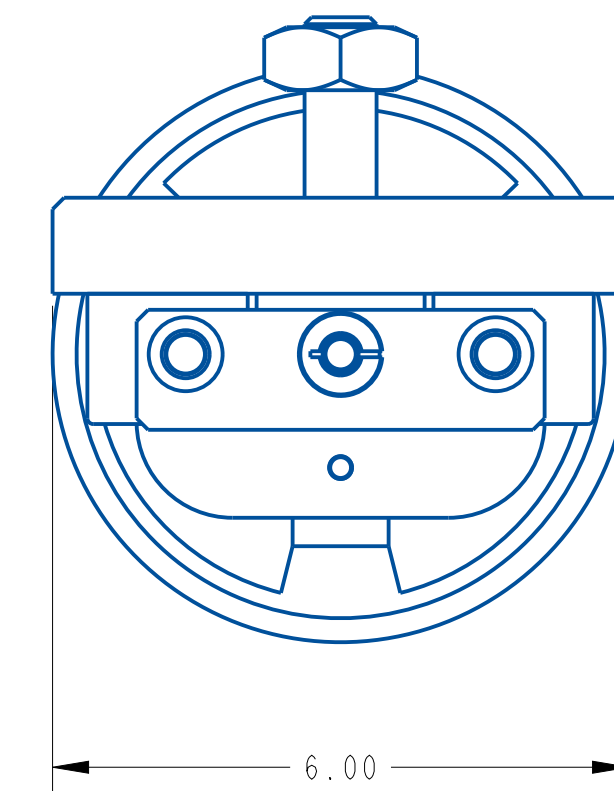
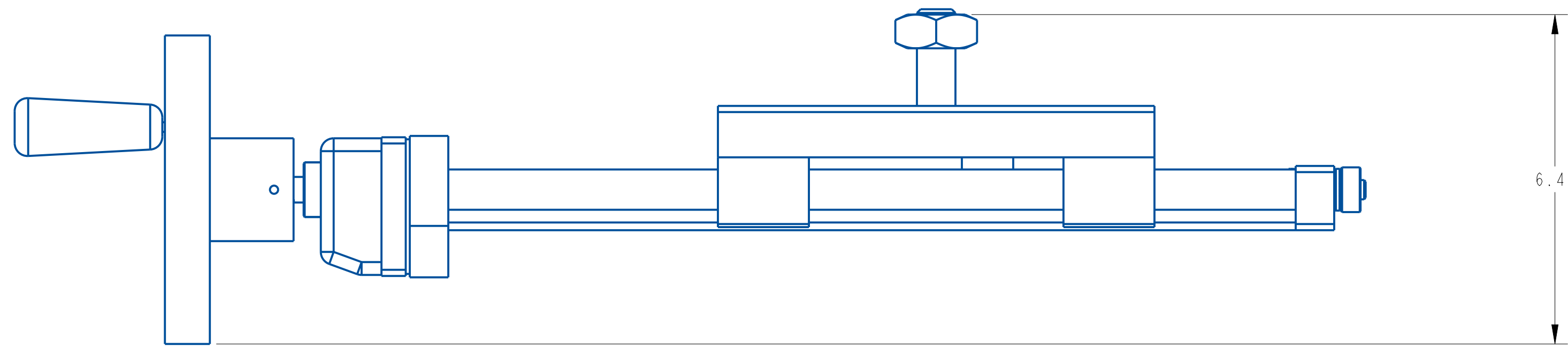
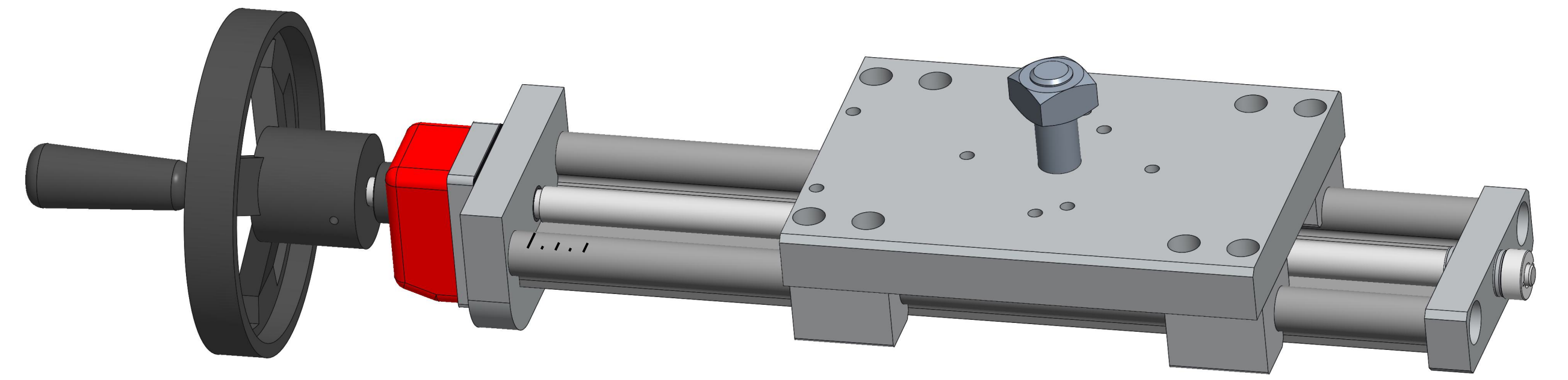
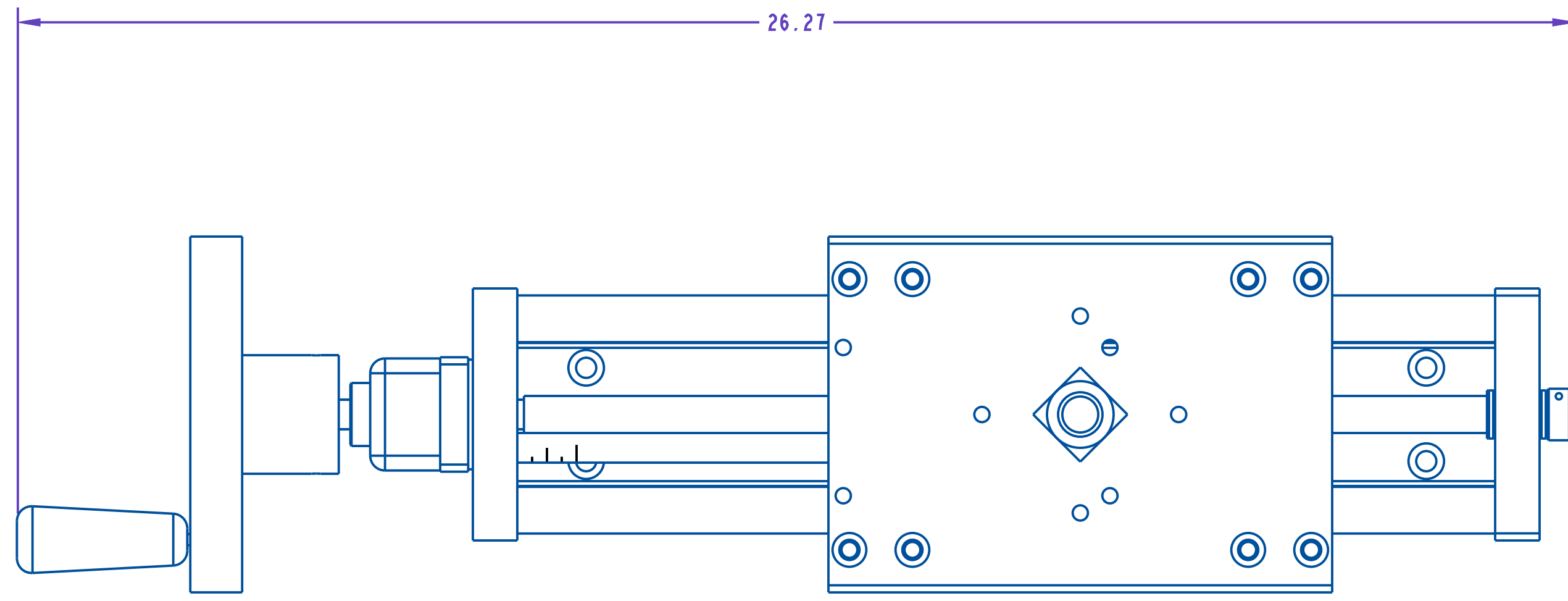

REV	DATE	DESCRIPTION	ATT	BY
A	3-25-20	NEW DRAWING		ATT

THIS IS A PRO-ENGINEER DOCUMENT AND MAY NOT BE MODIFIED MANUALLY

UNLESS OTHERWISE SPECIFIED DIMENSIONAL TOLERANCE	x ± .1 xx ± .01 xxx ± .005 ANGLES ± .30° SURFACE FINISH 125 BREAK ALL EDGES .005/ .015 CORNER RADIUS .010/ .030 ALL ANGLES ARE 90°	QUADREL LABELING SYSTEMS 7670 JENTHER DRIVE MENTOR, OHIO 44060 (440) 602-4700	SCALE: 1/2 DATE: 3-25-20 DRW BY: ATT CHK BY: 03/02/24-SEM APPR BY:
VERTICAL IGUS SLIDE, 17.5"			
MAT'L	22173-000		22173-601

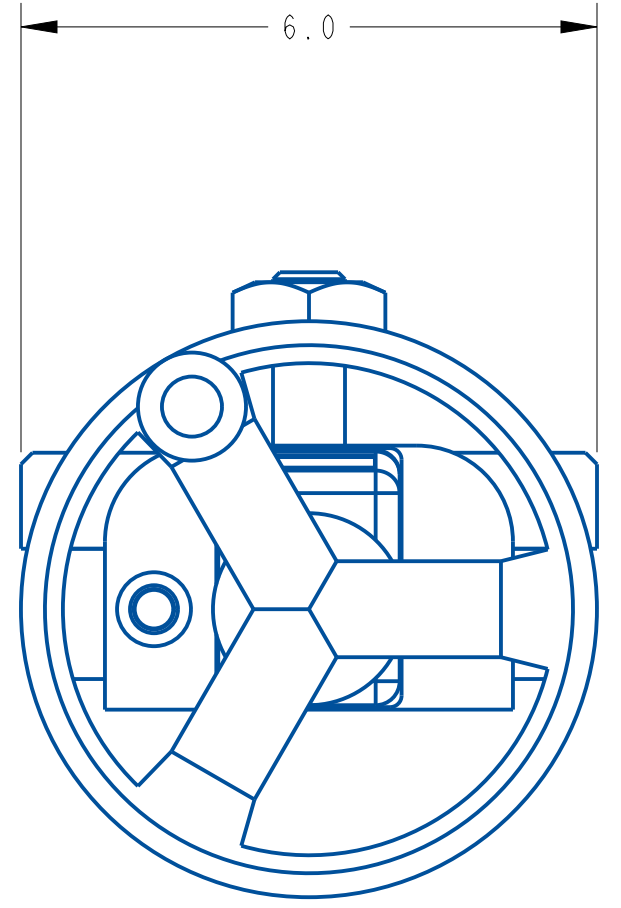
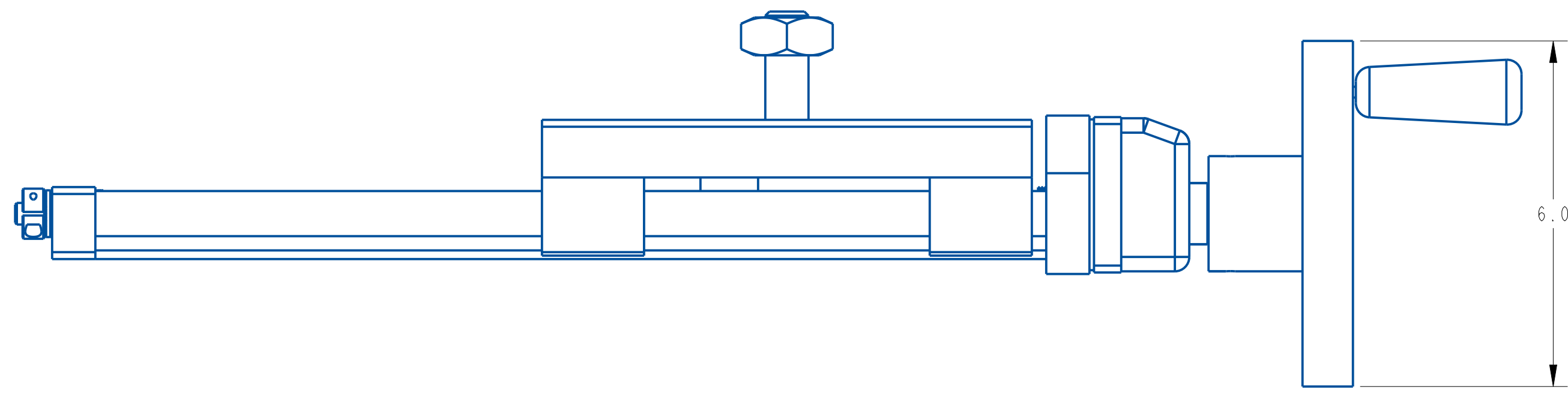
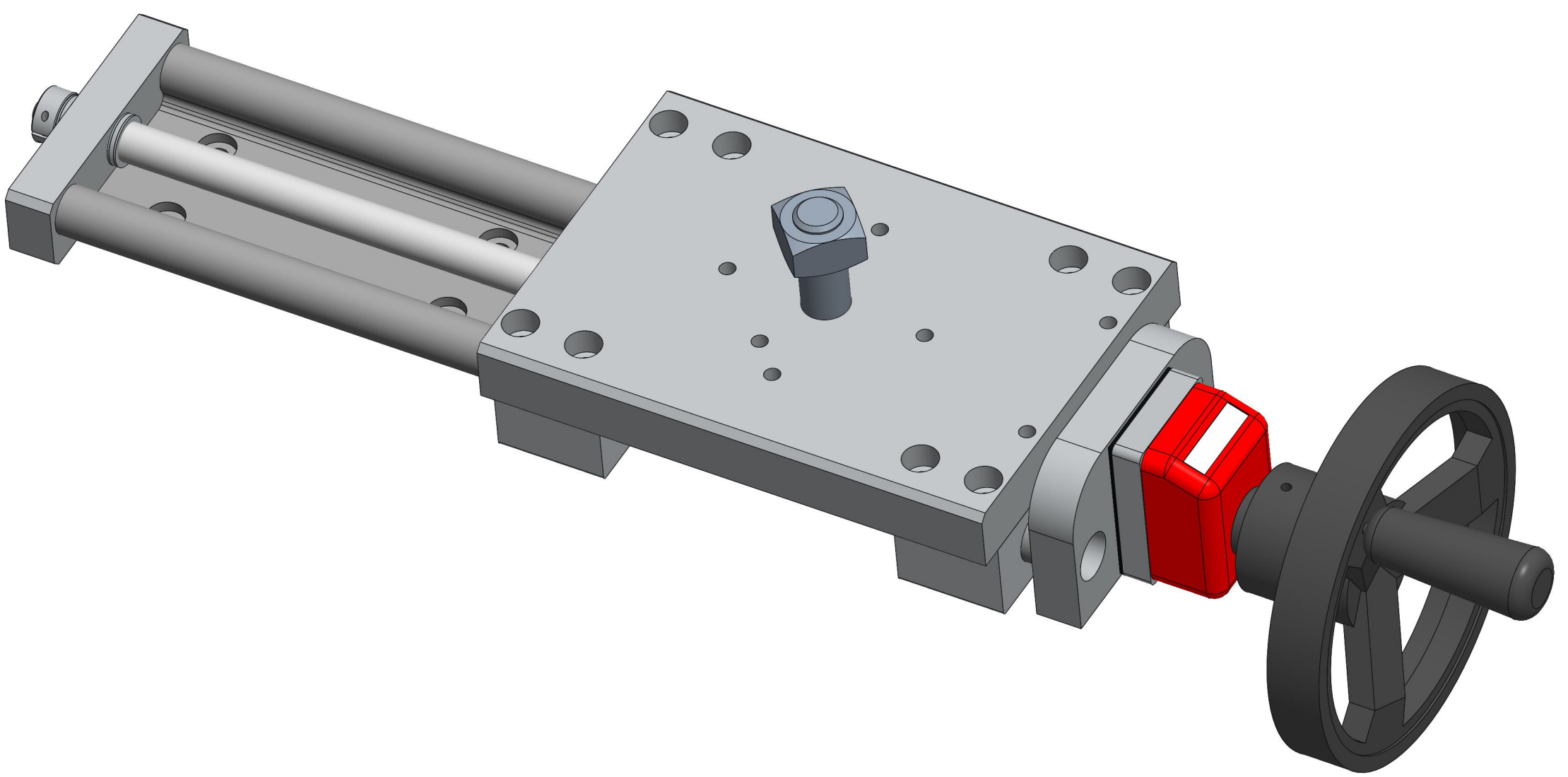
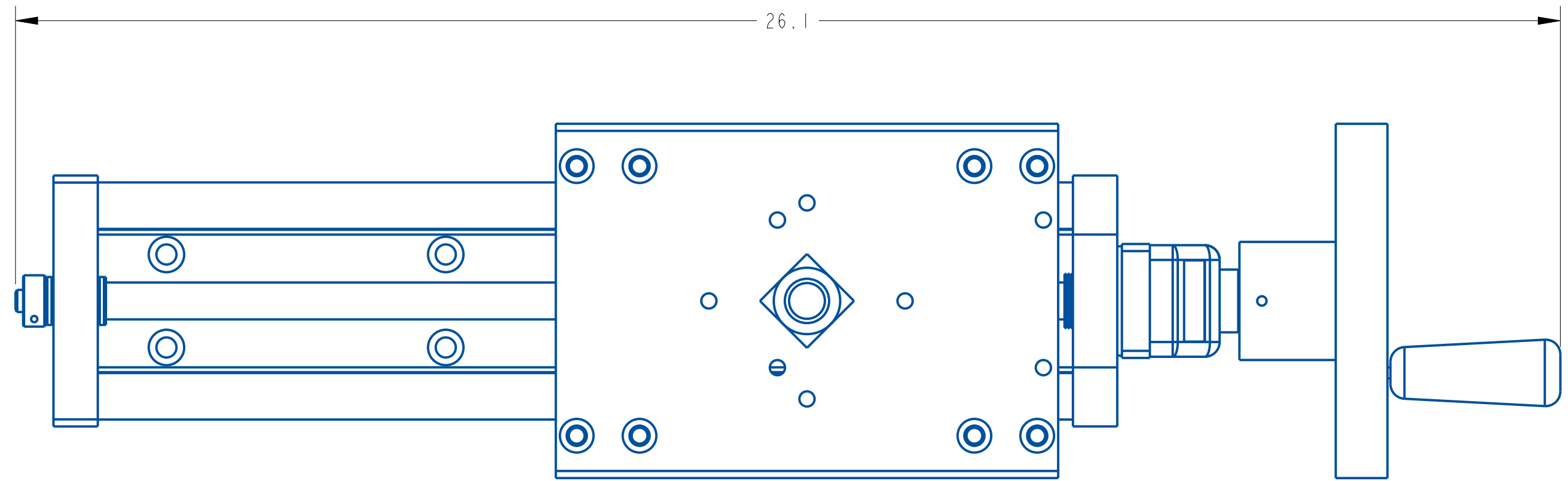

REV	DATE	DESCRIPTION	BY
A	2-24-20	NEW DRAWING	TJS

THIS IS A PRO-ENGINEER DOCUMENT AND MAY NOT BE MODIFIED MANUALLY

UNLESS OTHERWISE SPECIFIED DIMENSIONAL TOLERANCE	.xx ± .01 .xxx ± .005 ANGLES ± .30° SURFACE FINISH 125 BREAK ALL EDGES .005/ .015 CORNER RADIUS .010/ .030 ALL ANGLES ARE 90°	QUADREL LABELING SYSTEMS 7670 JENTHER DRIVE MENTOR, OHIO 44060 (440) 602-4700	SCALE: 1/2 DATE: 2-24-20 DRW BY: TJS CHK BY: 03/02/24-SEM APPR BY:
---	---	---	--

MAT'L	VERTICAL IGUS SLIDE, 17.5"	22173H-601
-------	----------------------------	------------

ITEM	QTY	PART NO.	DESCRIPTION	PARENT ITEM
1	2	801850-000	CLAMPING LEVER	22620Y-RHH
2	2	B21190-114	YOKE SIDE PLATE	22620Y-RHH
3	1	B21555-000	MTG YOKE BACK PLATE	22620Y-RHH

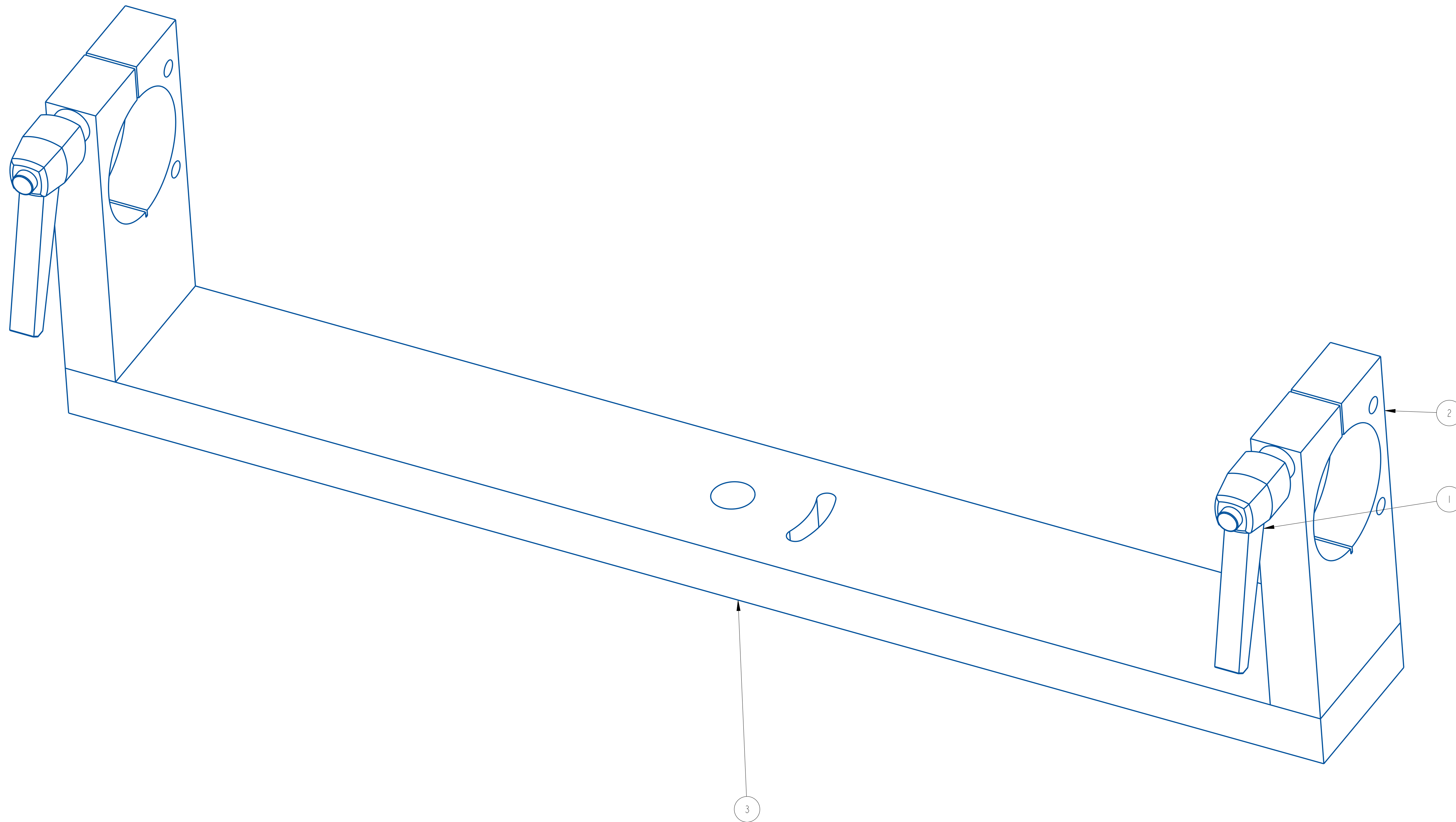

REV	DATE	DESCRIPTION	BY
A	11-26-13	NEW DRAWING	ATT

THIS IS A PRO-ENGINEER DOCUMENT AND MAY NOT BE MODIFIED MANUALLY

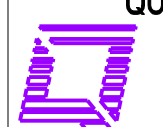
UNLESS OTHERWISE SPECIFIED DIMENSIONAL TOLERANCE .X ± .1 .XX ± .01 .XXX ± .005 ANGLES ± 30°	 7670 JENTHER DRIVE MENTOR, OHIO 44060 (440) 602-4700	SCALE: 1/1
		DATE: 11-26-13
		DRW BY: ATT
		CHK BY: 03/07/2024-SEM
Q120 YOKE ASSEMBLY		MAT'L
		22620Y-RHH

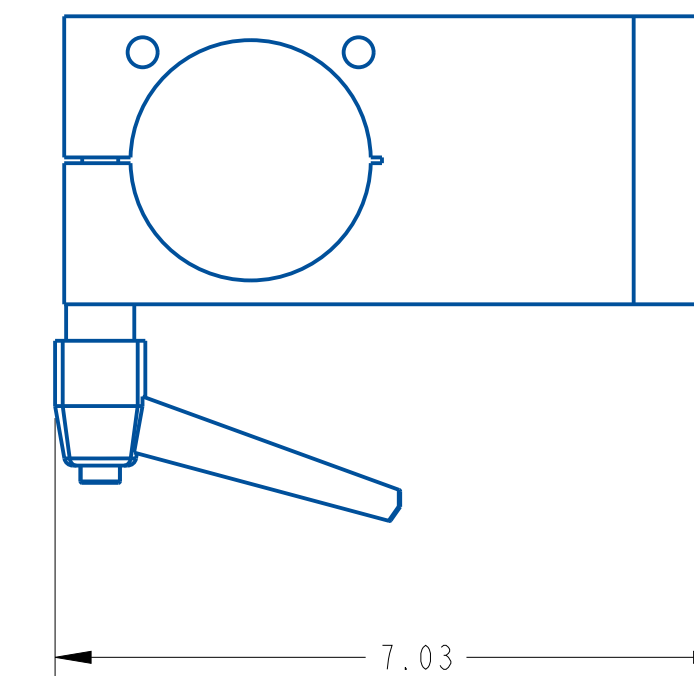
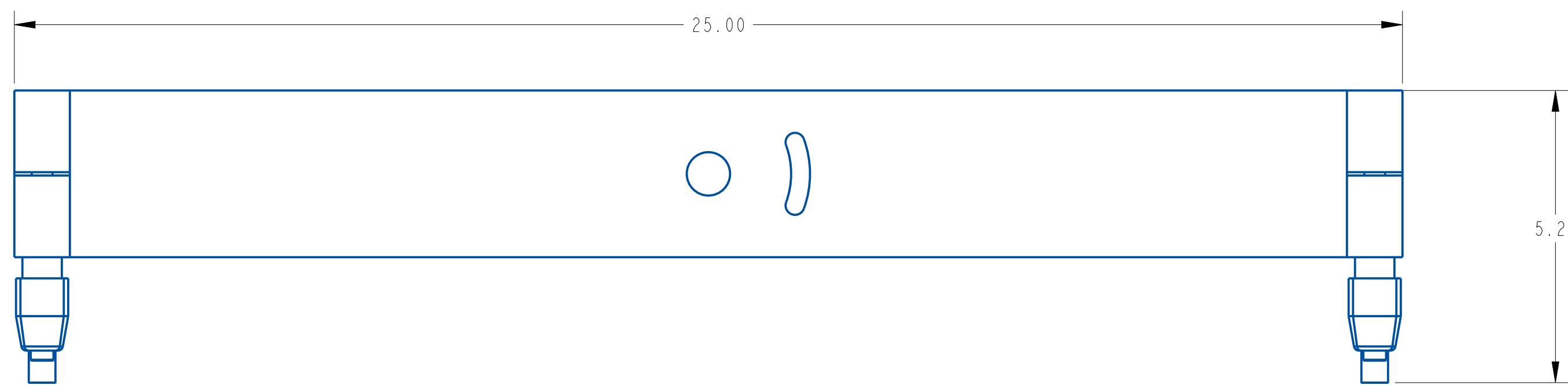
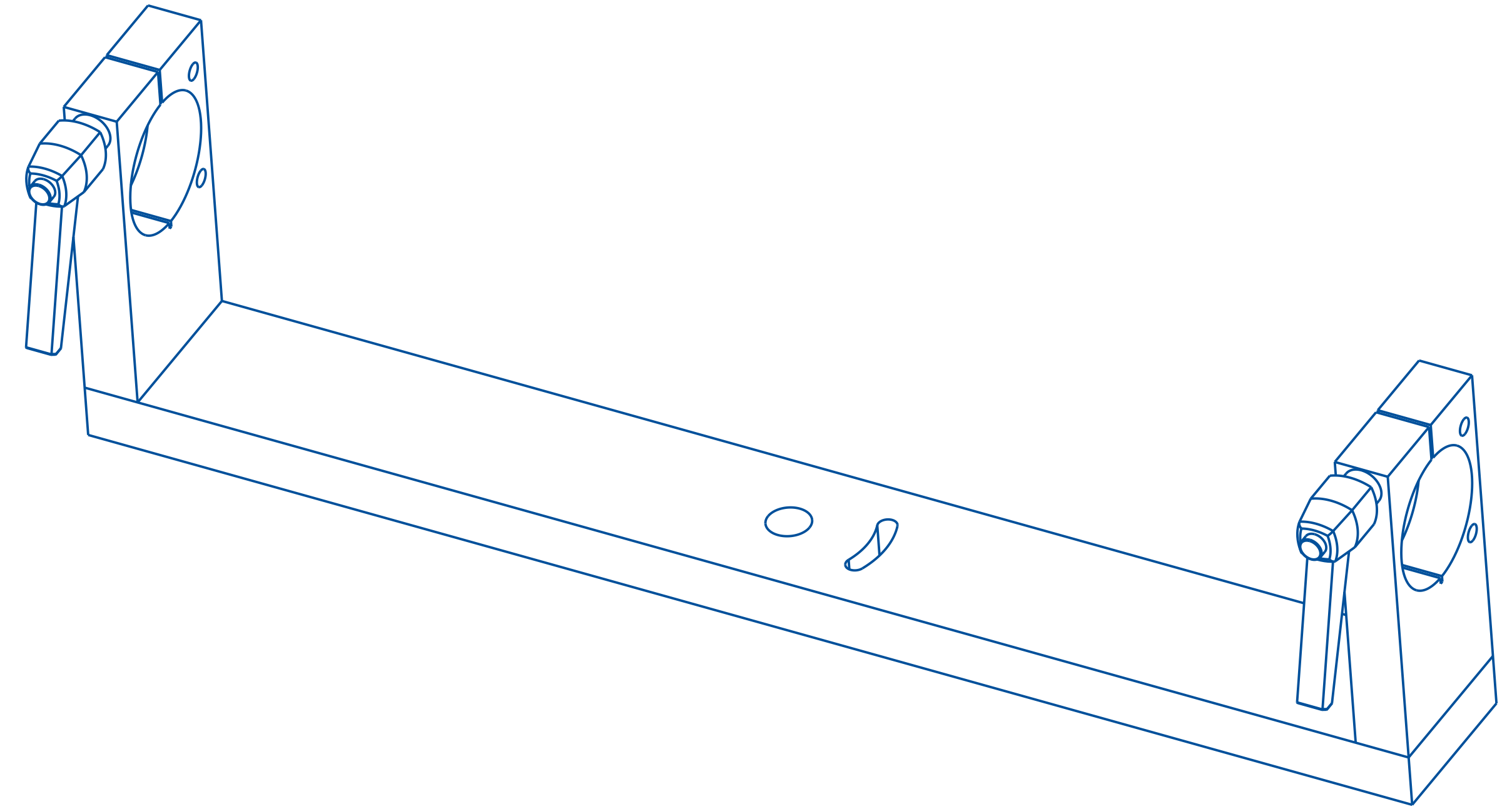
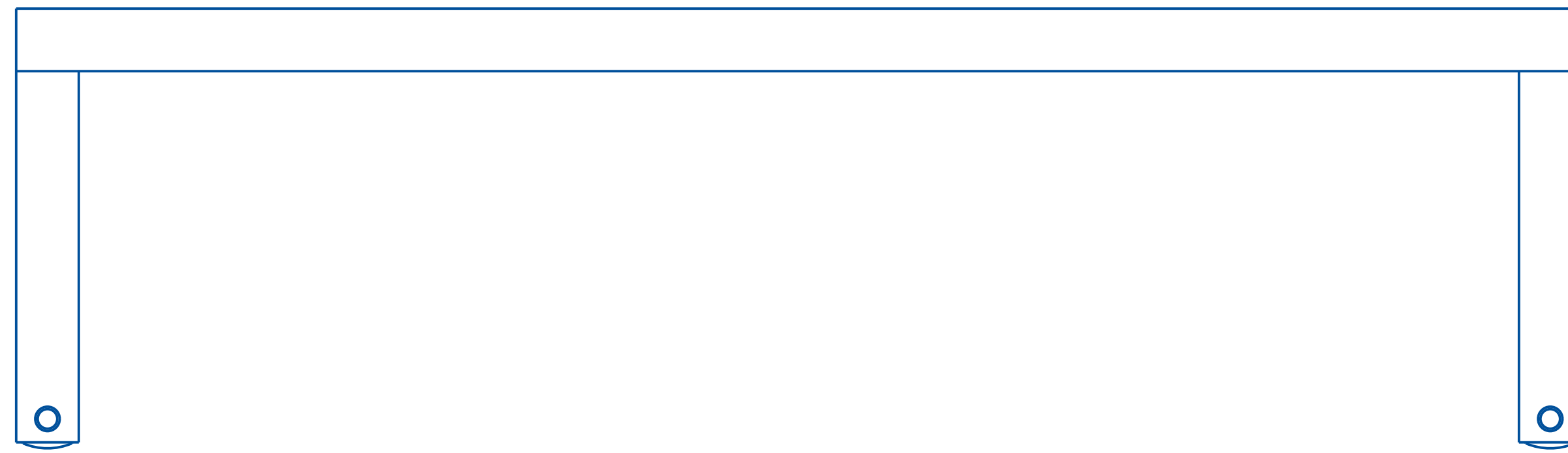

REV	DATE	DESCRIPTION	BY
A	11-26-13	NEW DRAWING	ATT

THIS IS A PRO-ENGINEER DOCUMENT AND MAY NOT BE MODIFIED MANUALLY

UNLESS OTHERWISE SPECIFIED
 DIMENSIONAL TOLERANCE
 X ± .1
 XX ± .01
 XXX ± .005
 ANGLES ± .30°
 SURFACE FINISH 125
 BREAK ALL EDGES .005/.015
 CORNER RADIUS .010/.030
 ALL ANGLES ARE 90°

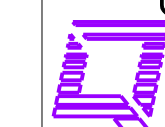

QUADREL LABELING SYSTEMS
 7670 JENTHER DRIVE
 MENTOR, OHIO 44060
 (440) 602-4700

SCALE: 1/2
 DATE: 11-26-13
 DRW BY: ATT
 CHK BY: 03/07/2024-SEM
 APPR BY:

Q120 YOKE ASSEMBLY

MAT'L

22620Y-RHH

7.4 PACING WHEEL / BELT ASSEMBLY

7.4.1 GENERAL INFORMATION

The pacing wheel/belt are an optional module that is generally placed at the entrance of the conveyor to allow adequate spacing of products as they travel towards the labeling head. The speed of the wheel/belt will vary how much spacing is created between the products. It is controlled by a DC motor and DC drive located in the electrical enclosure.

7.4.2 ADJUSTMENTS

The adjustments for both assemblies are fairly straight forward. The pacing wheel assembly has a pivoting in and out adjustment and height adjustment. The pivot in and out adjustment is made by loosening the ratcheting handle on the mount and rotating the assembly as needed.





The vertical adjustment for the pacing wheel is achieved by loosening the collar on the shaft then loosening the ratchet handle and manually pull up or push down as needed. The height is locked in place with the lock collar. Tighten the ratchet handle when finished.



CAUTION

Do not make any adjustments when assembly or conveyor are running.

The pacing belt assembly has both vertical and horizontal adjustments. To adjust vertically loosen the 2 3/8-16 bolts and pull up on the assembly. To adjust horizontally (in and out) loosen the 2 ratchet handles under the assembly and slide in and out as needed.



ASSEMBLY TITLE: PACING WHEEL ASSEMBLY

DRAWING NO.:

GENERAL FUNCTION:

- The product pacing wheel offsets each product a variable distance from the preceding product and guarantees adequate product separation.

SETUP AND ADJUSTMENTS:

- The mounting for the pacing wheel provides two axis of adjustment.
- Adjust the brackets so that the pacing wheel slightly presses the product against the back rail. Lock into place using the adjustment knobs.
- The speed of the pacing wheel is controlled by a potentiometer located on the remote enclosure mounted on the conveyor

MAINTENANCE:

- No scheduled maintenance is required for this assembly. Always keep the drive areas free of label flash and debris.

CAUTION: Before performing any maintenance or cleaning make sure the system is powered down.

TROUBLESHOOTING:

PROBLEM:

WHAT TO DO:

- | | |
|--------------------------------|--|
| - Product compressed | - Using the horizontal adjustment, relieve the horizontal position |
| - Pacing wheel tilts products | - Set wheel vertical position at horizontal center of product. |
| - Product spaced to close | - Adjust backing guide rail. |
| - Product spaced too far apart | - Reduce the speed of the pacing wheel. |
| | - Increase the speed of the pacing wheel. |

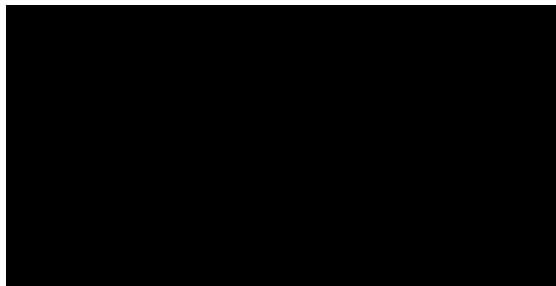

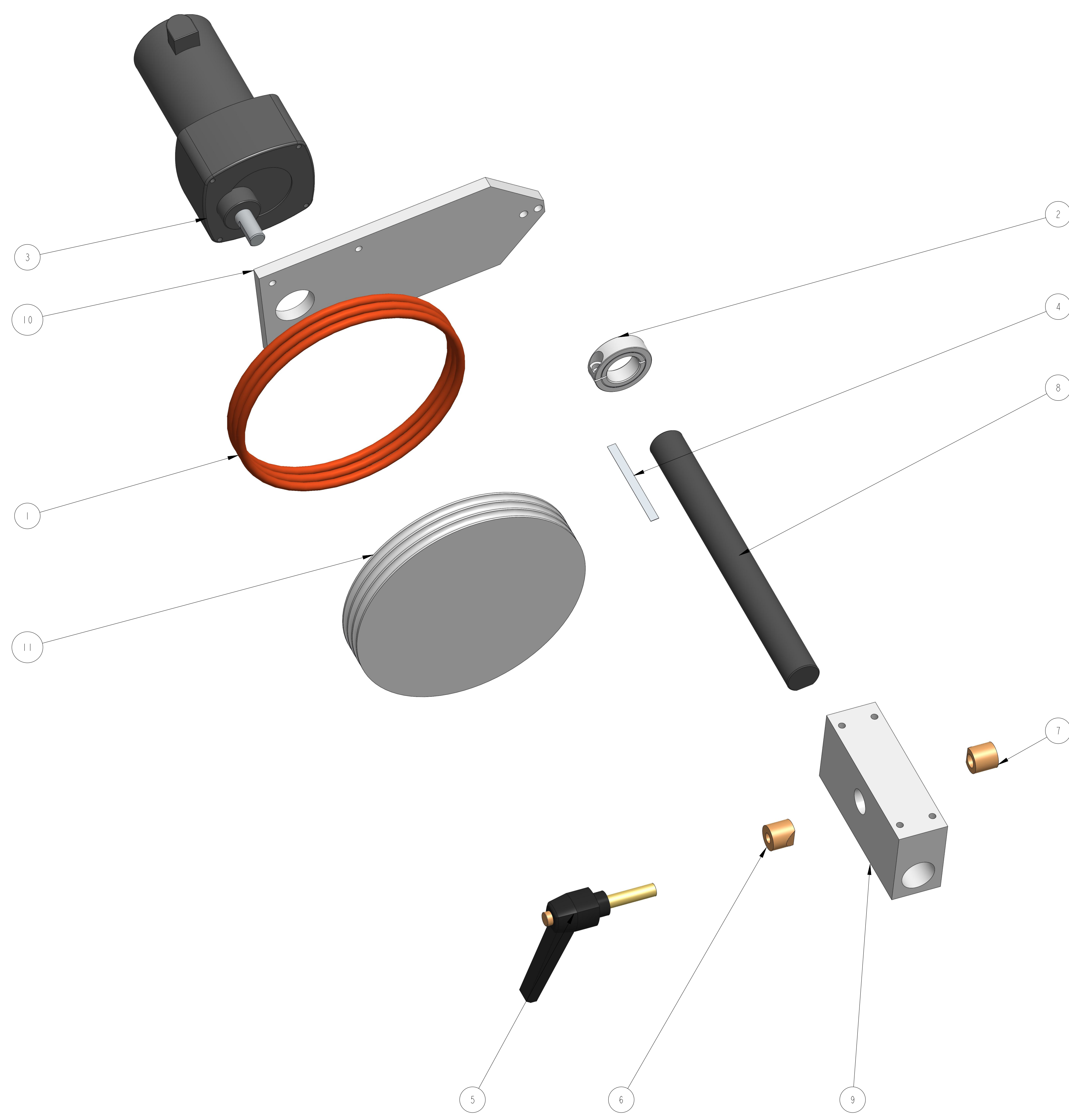

ITEM	QTY	PART NO.	DESCRIPTION	PARENT ITEM
1	3	291030-001	O-RING	20543-001
2	1	361905-001	COLLAR, 1 IN. ID ONE-PIECE CLAMP	20543-001
3	1	411293-000	MOTOR	20543-001
4	1	791914-002_03	MYLAR SCALE, QUADREL LOGO	20543-001
5	1	801805-000	CLAMPING LEVER	20543-001
6	1	A20688-000	LOCKING CLAMP	20543-001
7	1	A20689-000	LOCKING CLAMP	20543-001
8	1	A21426-002	GUIDE ROD	20543-001
9	1	A21691-000	MOUNTING BLOCK	20543-001
10	1	A23881-000	MOUNTING PLATE	20543-001
11	1	B21756-000	PACING WHEEL	20543-001

REV	DATE	DESCRIPTION	BY
A	03/01/24	NEW DRAWING	SEM

THIS IS A PRO-ENGINEER DOCUMENT AND MAY NOT BE MODIFIED MANUALLY

UNLESS OTHERWISE SPECIFIED DIMENSIONAL TOLERANCE X ± .1 XX ± .01 XXX ± .005 ANGLES ± 30°	QUADREL LABELING SYSTEMS 7670 JENTHER DRIVE MENTOR, OHIO 44060 (440) 602-4700		SCALE: 5/8
			DATE: 03/01/24
			DRW BY: SEM
			CHK BY: 03/18/2024-SEM
MODULINE O-RING PACING WHEEL ASSEMBLY		MAT'L	20543-001
			20543-001

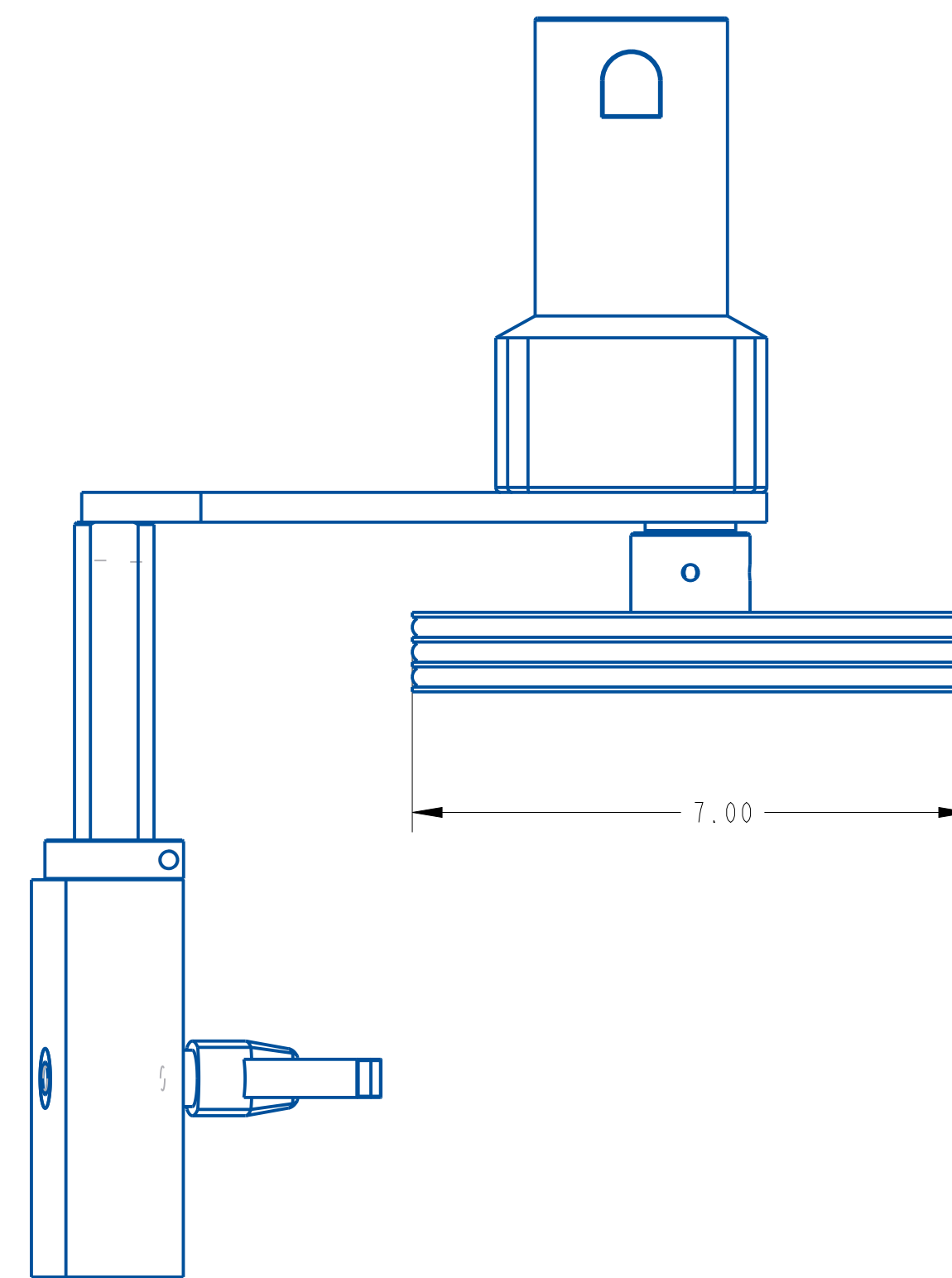
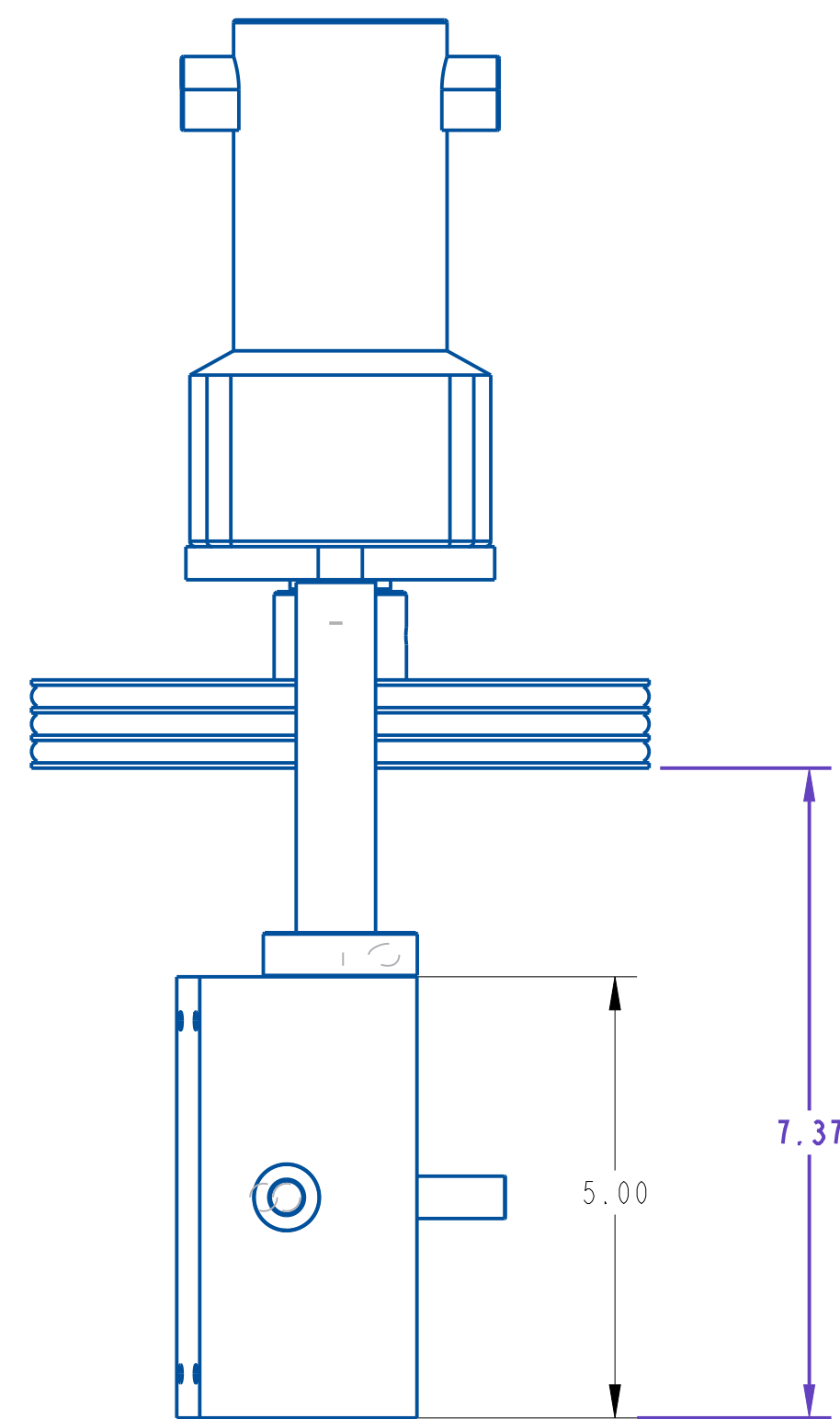
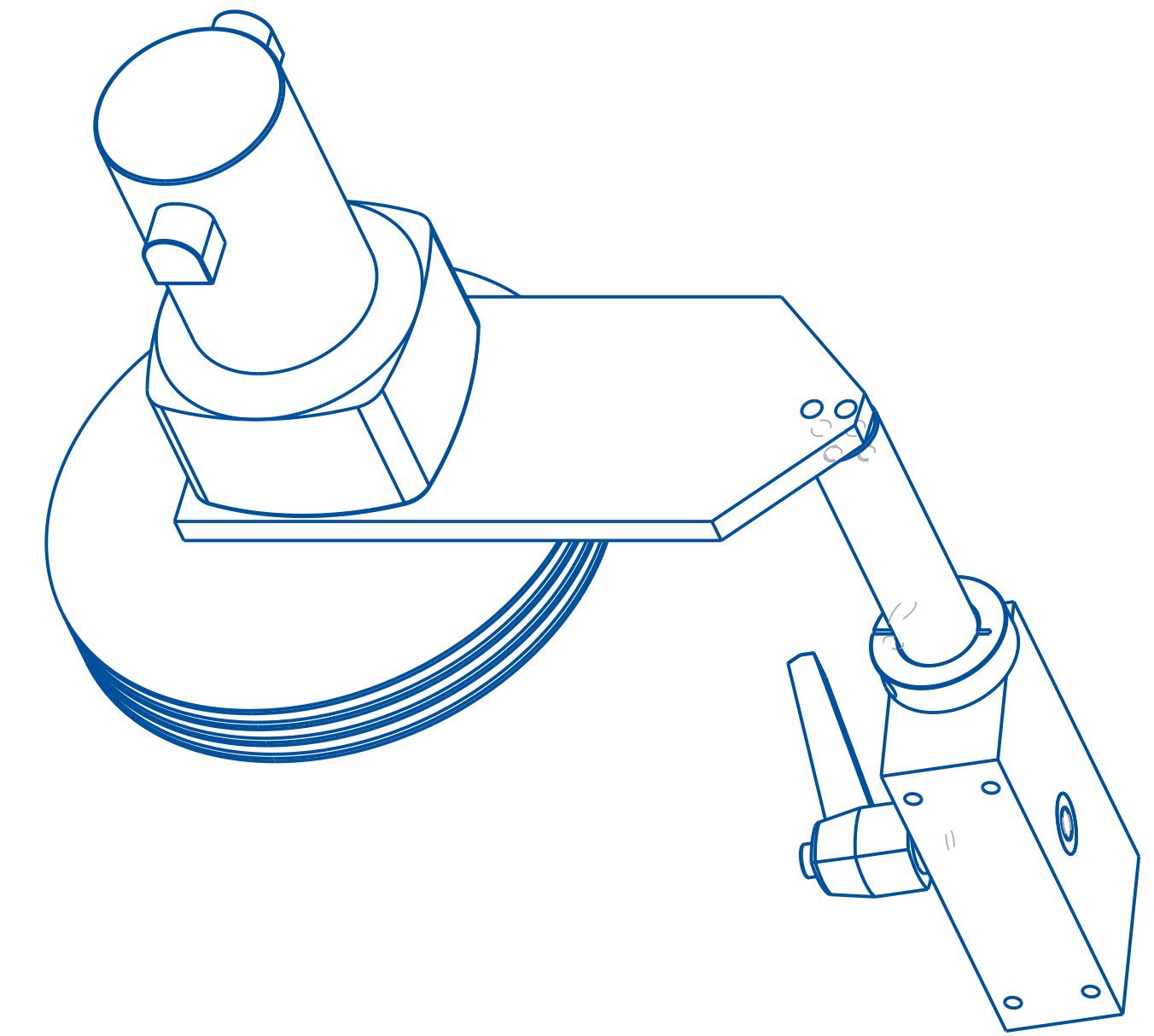
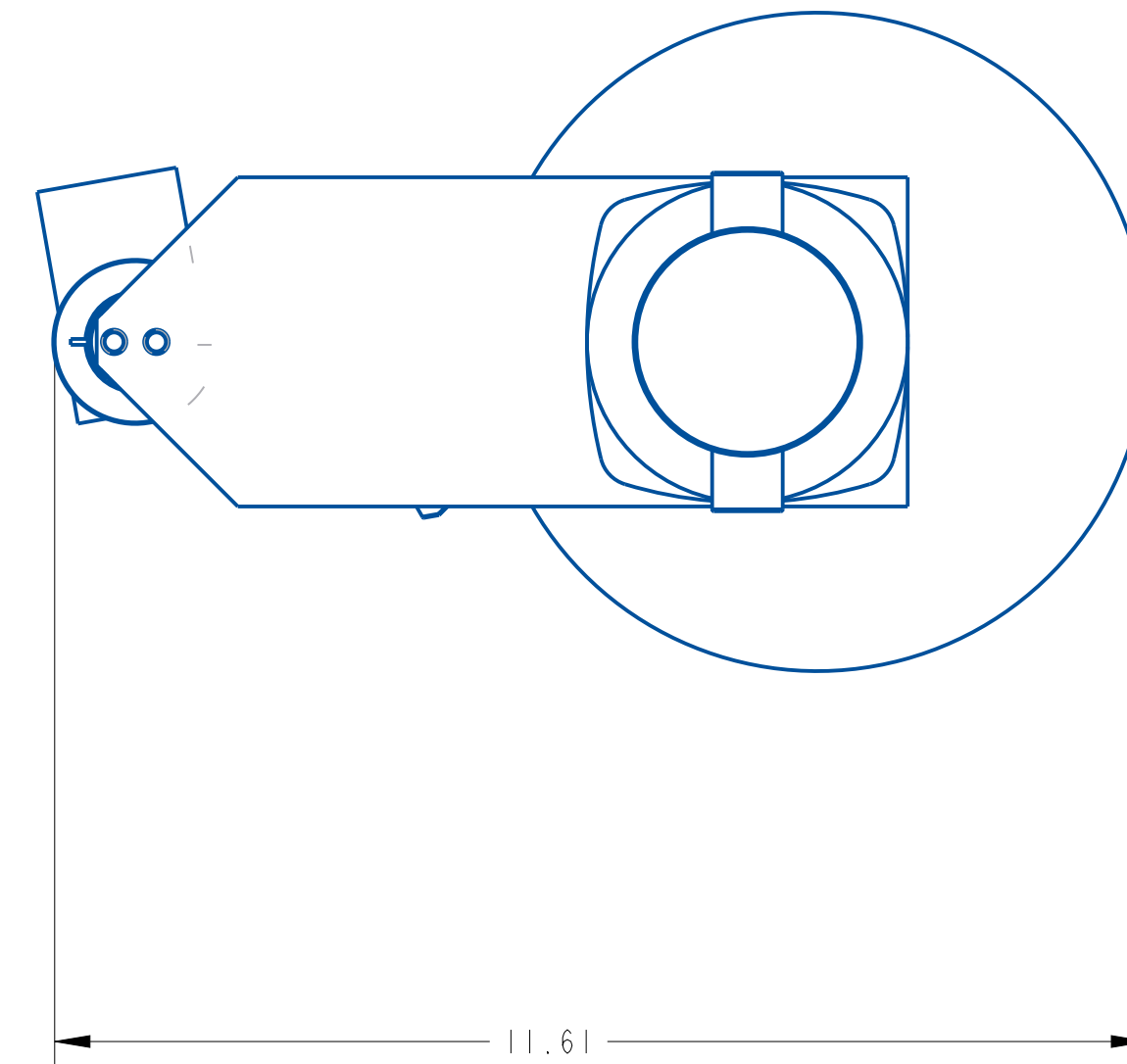

REV	DATE	DESCRIPTION
A	7-10-13	NEW DRAWING

THIS IS A PRO-ENGINEER DOCUMENT AND MAY NOT BE MODIFIED MANUALLY

UNLESS OTHERWISE SPECIFIED DIMENSIONAL TOLERANCE .x ± .1 .xx ± .01 .xxx ± .005 ANGLES ± 30°	QUADREL LABELING SYSTEMS 7670 JENTHER DRIVE MENTOR, OHIO 44060 (440) 602-4700		SCALE: 1/2 DATE: 7-10-13 DRW BY: DC CHK BY: 03/18/2024-SEM APPR BY:
	MODULINE O-RING PACING WHEEL ASSEMBLY		
	SURFACE FINISH 125 BREAK ALL EDGES .005/0.15 CORNER RADIUS .010/0.30	MAT'L 20543-001	20543-001
	SHEET 2 OF 2		

7.7 TOP HOLD DOWN ASSEMBLY

7.7.1 GENERAL INFORMATION

The top hold down module is a motor driven spring loaded belt that applies overhead pressure to the containers and enables the product to remain stable as the label is applied. This assembly is powered by an AC motor or servo motor. Ideal for front / back or single side applications.

7.7.2 ADJUSTMENTS

Adjusting the height of the top hold down is achieved by turning the hand wheel on the top of the assembly counter clockwise or clockwise.



ASSEMBLY TITLE:

TOP TRAP ASSEMBLY

GENERAL FUNCTION:

- As a product enters the label application area near the labeling head, it needs additional support to prevent it from being upset as a label is applied. A product hold down conveyor or more commonly known as a "top trap" is used to provide product support.

The speed of the top trap is set to match the speed of the conveyor and is encoder matched to follow conveyor speed changes.

SETUP AND ADJUSTMENTS:

- Place the product to be labeled under the top trap. Loosen clamp lever and turn the **hand wheel** so that the rubber belt of the top trap compresses the product slightly.
- When the desired height is achieved, tighten the clamp lever.
- **The top trap is spring loaded to accommodate products that vary in height slightly.**
- Top trap belt tension can be adjusted by tightening or loosening the set screws at the infeed end of the top trap.

MAINTENANCE:

- No maintenance is required except for an occasional belt replacement.

TROUBLESHOOTING:

PROBLEM

- Top trap jumping teeth
- Too much pressure on product
- Top trap not moving

- Top trap swaying under load.

WHAT TO DO

- Tighten top trap belt
- Raise top trap
- Check drive belts and replace if broken.
- Tighten clamp lever. Tighten pulleys and shafts.



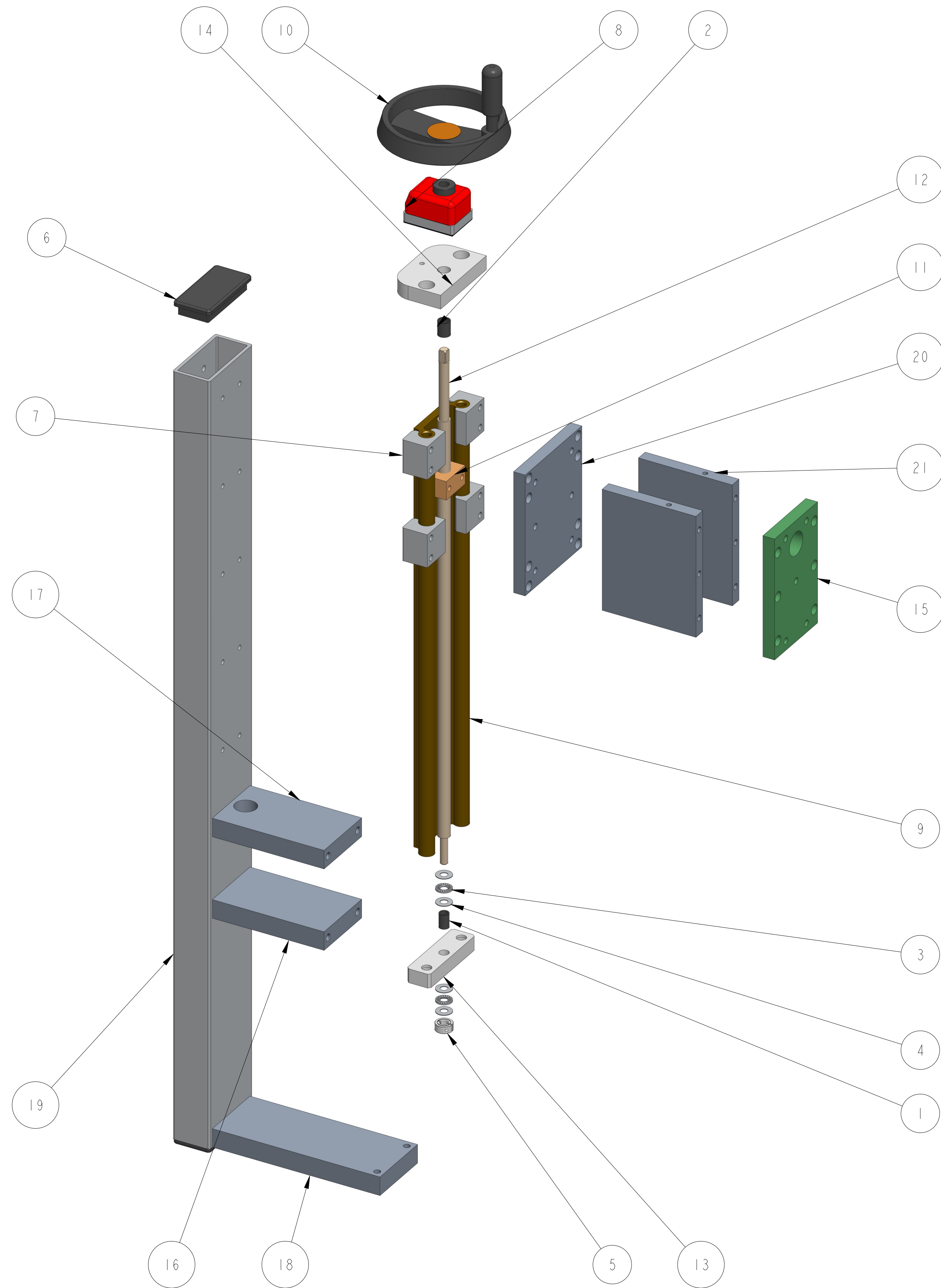

ITEM	QTY	PART NO.	DESCRIPTION	PARENT ITEM
1	1	141172-000	SLEEVE BEARING, 1/2OD. x 3/8ID. x 3/4LNG	22867-00
2	1	141177-000	SLEEVE BEARING, 5/8OD. x 1/2ID. x 3/4LNG	22867-00
3	2	181108-000	BEARING, NEEDLE ROLLER	22867-00
4	4	181111-000	THRUST WASHER	22867-00
5	1	362186-000	COLLAR, 3/8 IN. ID ONE-PIECE CLAMP	22867-00
6	2	729006-000	CAP INSERT FOR 2 X 4 TUBE	22867-00
7	4	792248-001	PILLOW BLOCK	22867-00
8	1	792354-002	DIGITAL POSITION INDICATOR	22867-00
9	1	793035-001	DRYLIN RAIL	22867-00
10	1	801080-000	6" HANDWHEEL	22867-00
11	1	A24077-000	BRONZE NUT, RH	22867-00
12	1	B20045-200	THREADED ROD	22867-00
13	1	B21346-000	BOTTOM BEARING PLATE	22867-00
14	1	B22005-012	BEARING PLATE	22867-00
15	1	B22790-002	TOP PACING CONNECTOR PLATE	22867-00
16	1	B22791-010	TOP TRAP SPACER	22867-00
17	1	B22791-011	TOP TRAP SPACER	22867-00
18	1	B22791-012	TOP TRAP SPACER	22867-00
19	1	C21292-001	TOP TRAP RISER	22867-00
20	1	C21293-001	TOP TRAP MOUNTING PLATE	22867-00
21	2	C21293-83516	TOP TRAP MOUNTING PLATE	22867-00

REV	DATE	DESCRIPTION	BY
A	22-AUG-2024	NEW DRAWING	CRT

THIS IS A PRO-ENGINEER DOCUMENT AND MAY NOT BE MODIFIED MANUALLY

UNLESS OTHERWISE SPECIFIED DIMENSIONAL TOLERANCE .1 .01 .005 ANGLES ± 30° SURFACE FINISH 125 BREAK ALL EDGES .005/.015 CORNER RADIUS .010/.030	7670 JENTHER DRIVE MENTOR, OHIO 44060 (440) 602-4700	SCALE: 0.313
		DATE: 22-AUG-2024
		DRW BY: CRT
		CHK BY: 08/22/2024-SEM
TOP PACING UPRIGHT ASSEMBLY, 2" W CONVEYORS		MAT'L
		22867-00

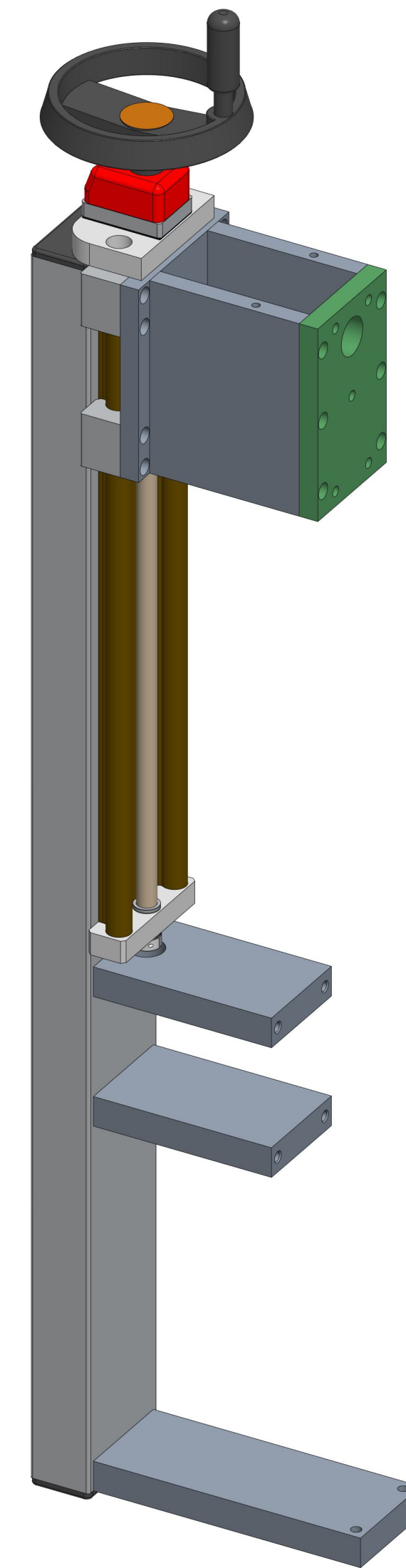
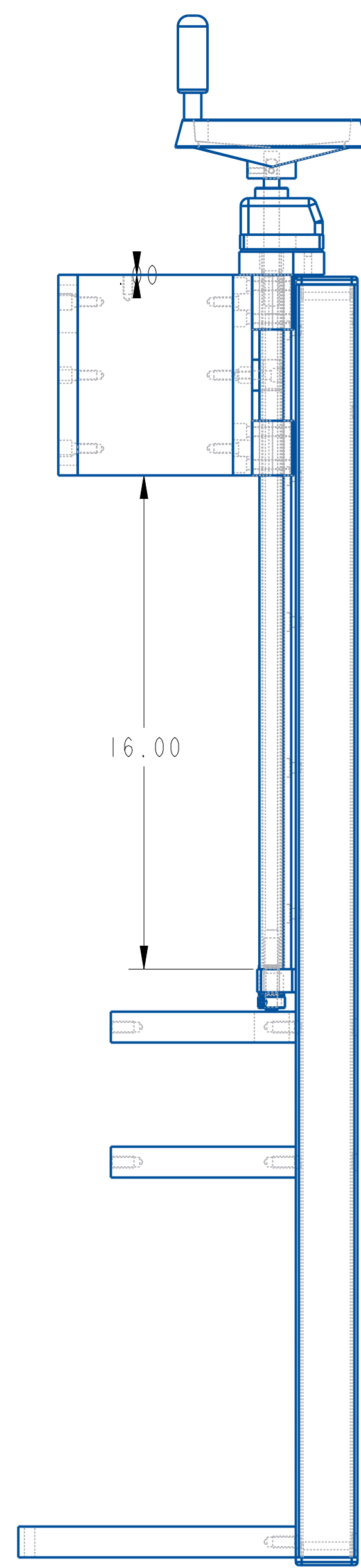
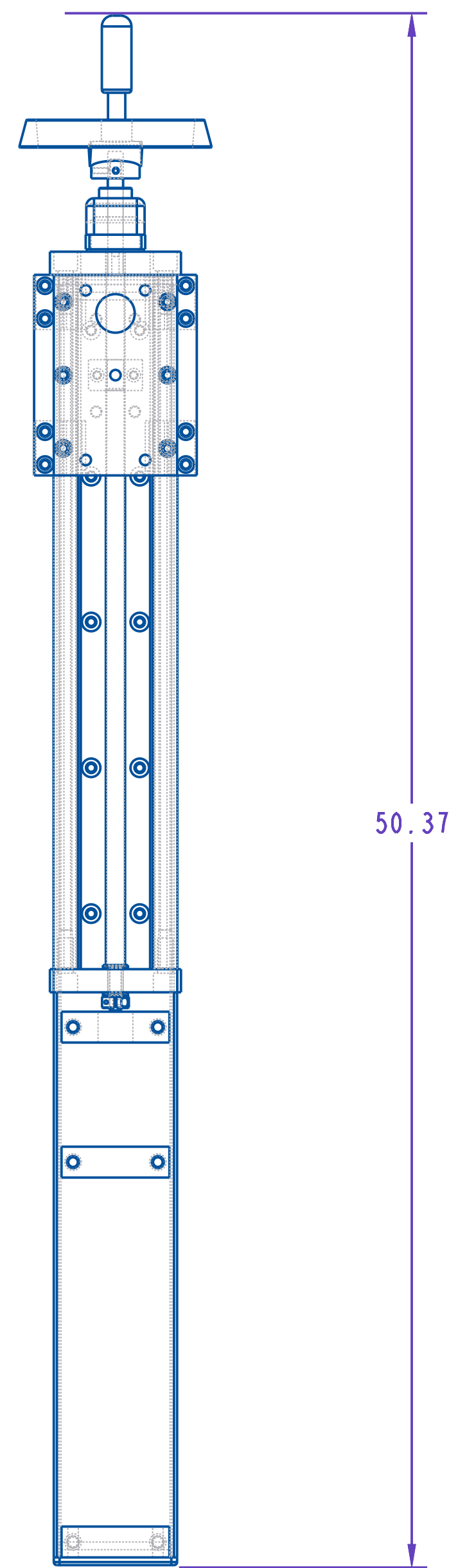
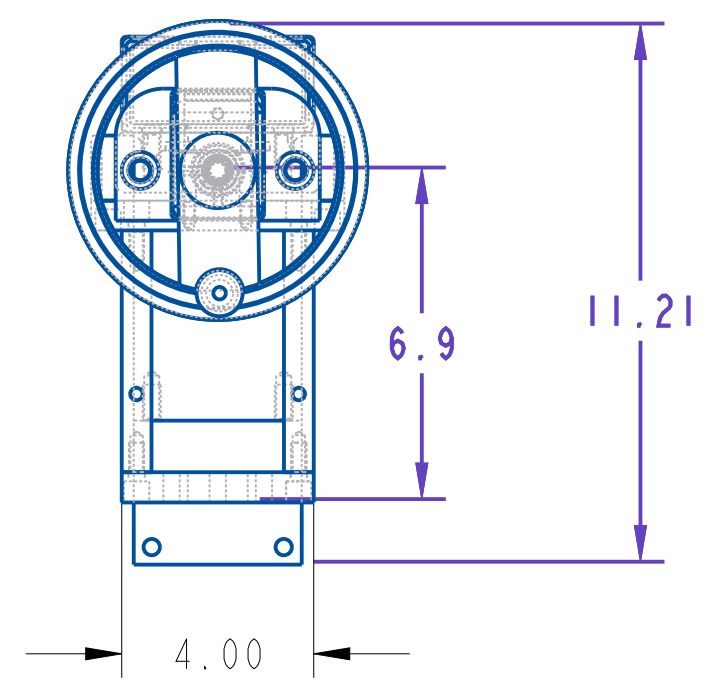

REV	DATE	DESCRIPTION	BY
A	08/28/24	NEW DRAWING	CRT

THIS IS A PRO-ENGINEER DOCUMENT AND MAY NOT BE MODIFIED MANUALLY

UNLESS OTHERWISE SPECIFIED DIMENSIONAL TOLERANCE	QUADREL LABELING SYSTEMS 7670 JENTHER DRIVE MENTOR, OHIO 44060 (440) 602-4700	SCALE: 0.250 DATE: 08/27/24 DRW BY: CRT CHK BY: 08/22/2024-SEM APPR BY:
.1 .01 .005 ANGLES ± 30°	TOP PACING UPRIGHT ASSEMBLY, 2" W CONVEYORS	MAT'L 22867-00

ITEM	QTY	PART NO.	DESCRIPTION	PARENT ITEM
1	2	111075-000	BEARING, BALL	22868-00R
2	2	151008-000	BEARING, THRUST WASHER	22868-00R
3	1	413016-000	GEARMOTOR-3/8HP-57 RPM 3PHASE	22868-00R
4	22	791975-001	R-CLIP	22868-00R
5	1	793013-000	QUADREL Logo (3"x11")	22868-00R
6	22	811256-000	COMPRESSION SPRING	22868-00R
7	1	A21578-040	TOP TRAP COVER PLATE	22868-00R
8	1	A21578-041	TOP TRAP COVER PLATE	22868-00R
9	1	A21823-000	IDLER SHAFT	22868-00R
10	1	A21830_601	TIMING BELT, RED LINOTEX	22868-00R
11	1	A25122-600	DRIVE PULLEY	22868-00R
12	1	A25122-602	IDLER PULLEY	22868-00R
13	6	A26053-000	SPACER	22868-00R
14	2	A26197-000	PULLEY FLANGE	22868-00R
15	1	B21769-000	TOP TRAP SPACER	22868-00R
16	22	B22784-000	SPRING BLOCK STEM	22868-00R
17	22	B22785-000	SPRING BLOCK PLATE	22868-00R
18	1	C21268-840	INSIDE TOP TRAP PLATE	22868-00R
19	1	C21268-841	INSIDE TOP TRAP PLATE	22868-00R
20	1	D24415-000	SPRING BLOCK MOUNTING CHANNEL	22868-00R
21	1	D24415-001	SPRING BLOCK MOUNTING CHANNEL	22868-00R

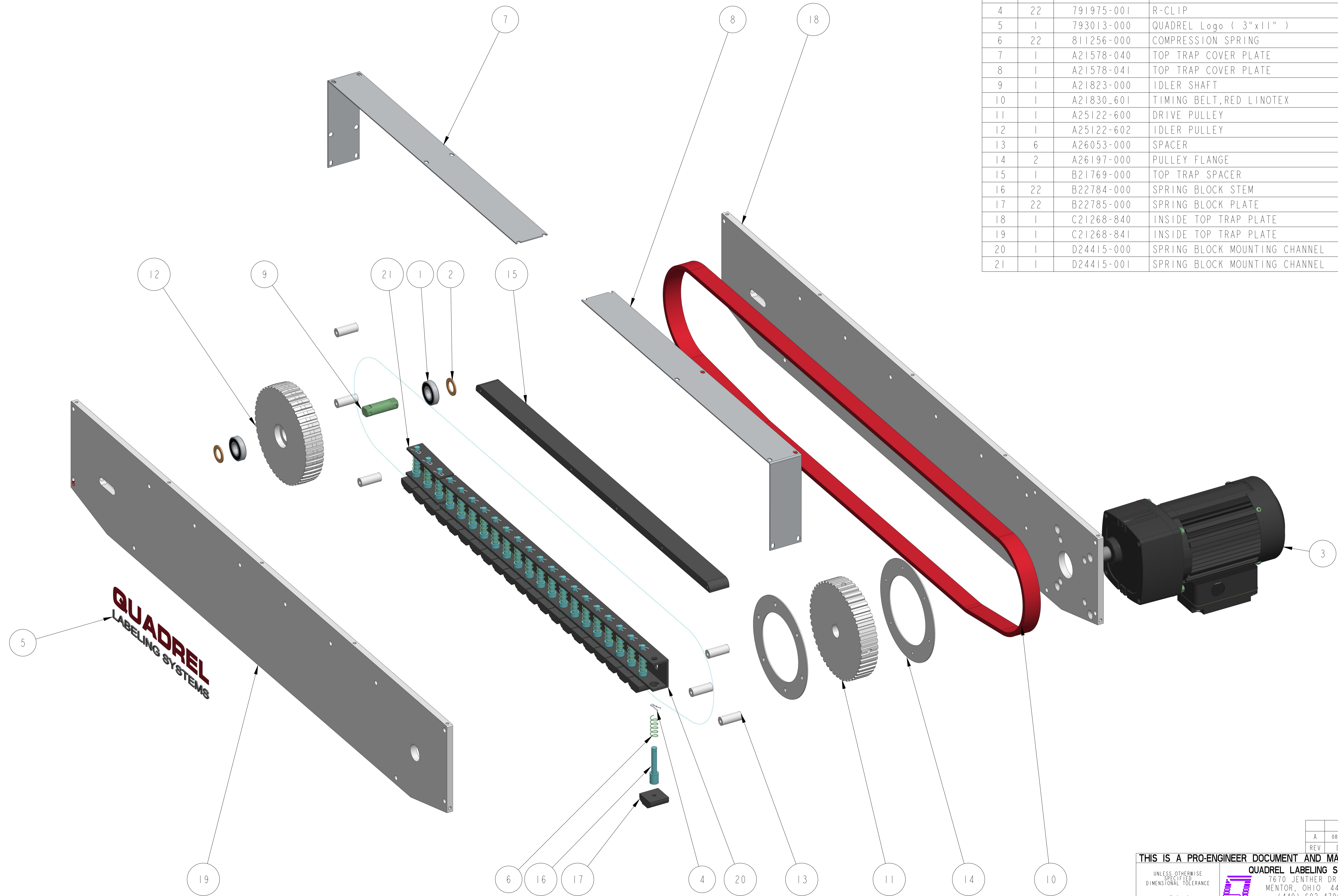

REV	DATE	DESCRIPTION	BY
A	08/26/24	NEW DRAWING	CRT

THIS IS A PRO-ENGINEER DOCUMENT AND MAY NOT BE MODIFIED MANUALLY

UNLESS OTHERWISE SPECIFIED
DIMENSIONAL TOLERANCE
 X ± .1
 XX ± .01
 XXX ± .005
 ANGLES ± 30°

SURFACE FINISH 125
 BREAK ALL EDGES .005/ .015
 CORNER RADIUS .010/ .030

QUADREL LABELING SYSTEMS
 7670 JENTHER DRIVE
 MENTOR, OHIO 44060
 (440) 602-4700

SCALE: 0.380
 DATE: 08/26/24
 DRW BY: CRT
 CHK BY: 08/26/2024-SEM
 APPR BY:

TOP TRAP BODY ASSEMBLY

MAT'L 22868-00R

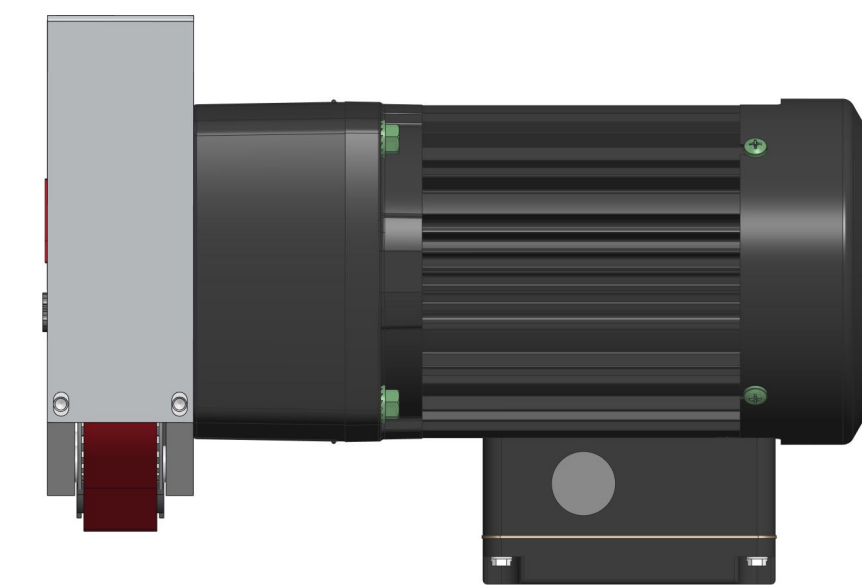
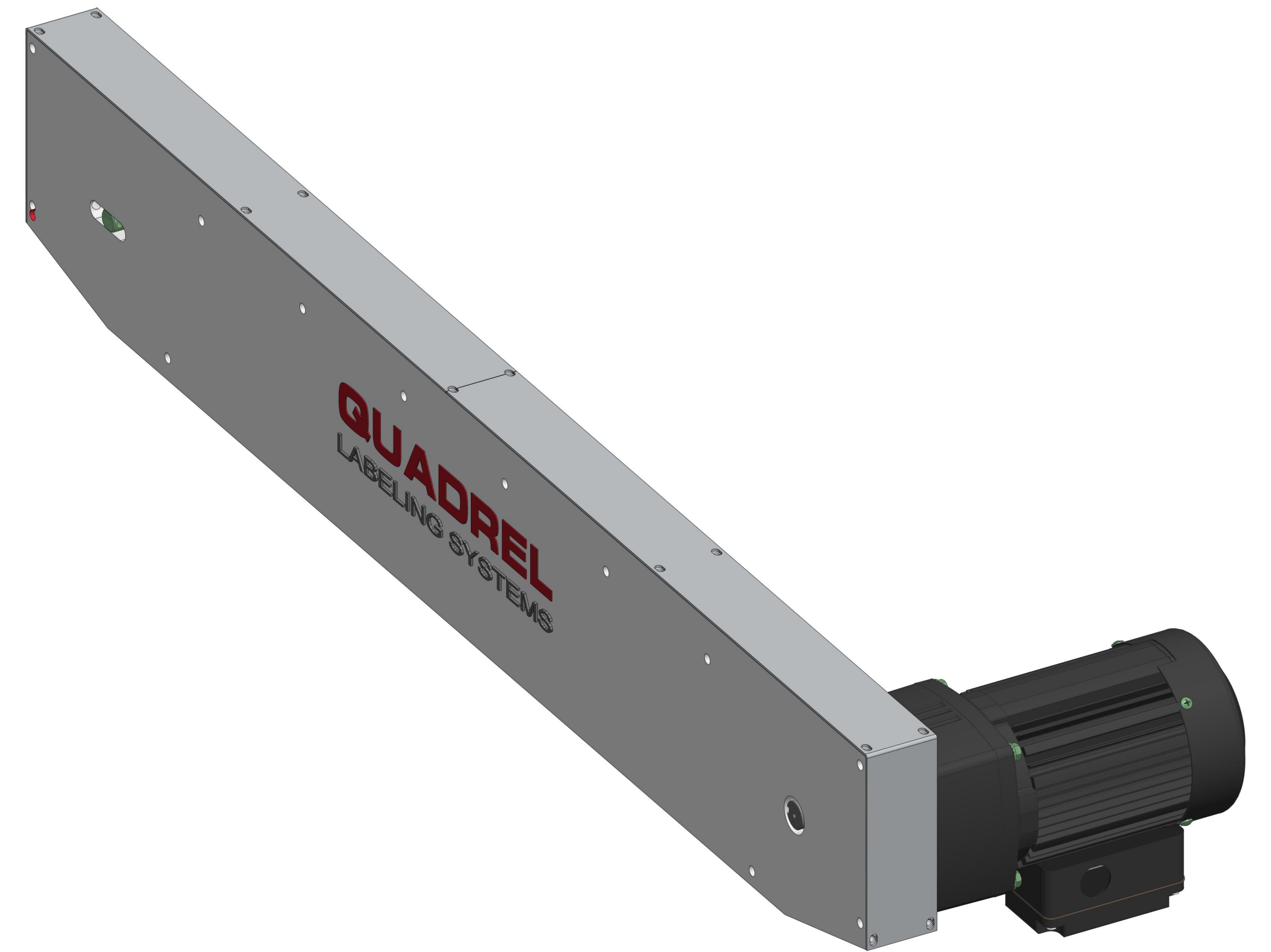
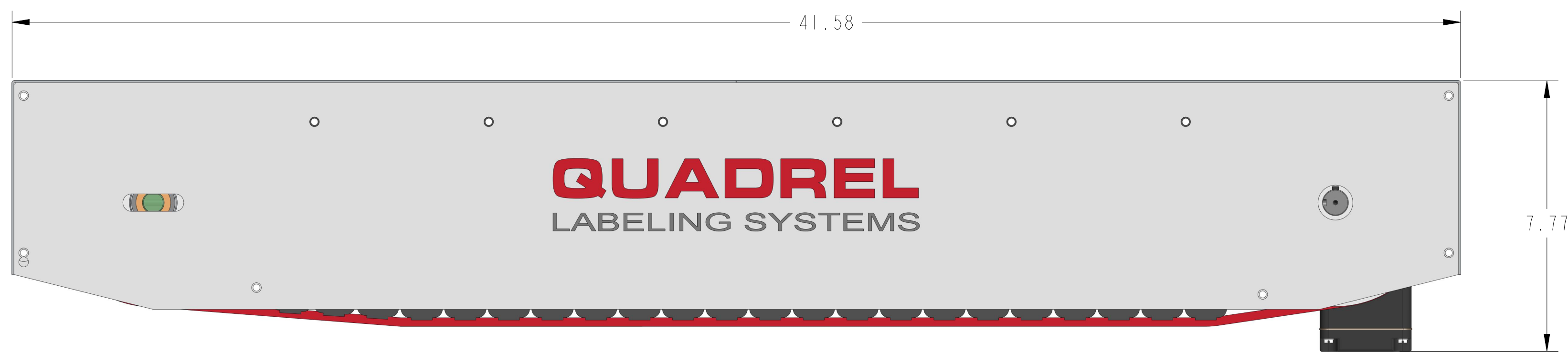
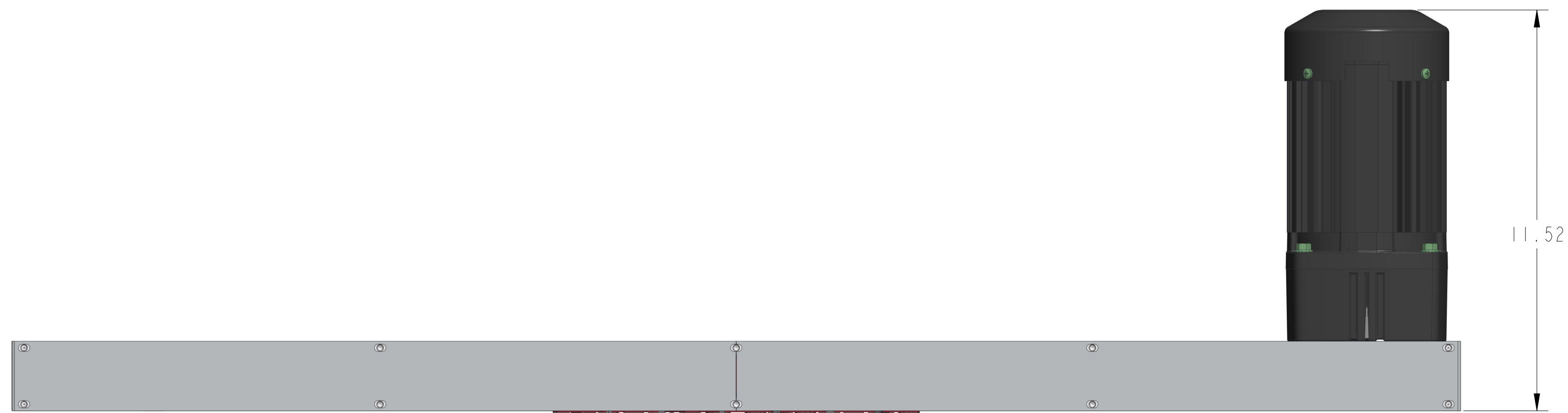

REV	DATE	DESCRIPTION	BY
A	24-AUG-2024	NEW DRAWING	CRT

<p>THIS IS A PRO-ENGINEER DOCUMENT AND MAY NOT BE MODIFIED MANUALLY</p> <p>UNLESS OTHERWISE SPECIFIED DIMENSIONAL TOLERANCE</p> <p> x ± .1 xx ± .01 xxx ± .005 ANGLES ± 30° </p> <p> SURFACE FINISH 125 BREAK ALL EDGES .005/0.15 CORNER RADIUS .010/0.30 </p>		<p>SCALE: 0.380</p> <p>DATE: 24-AUG-2024</p> <p>DRW BY: CRT</p> <p>CHK BY: 08/26/2024-SEM</p> <p>APPR BY:</p>
<p>QUADREL LABELING SYSTEMS</p> <p>7670 JENTHER DRIVE MENTOR, OHIO 44060 (440) 602-4700</p>		<p>TOP TRAP BODY ASSEMBLY</p>
<p>MAT'L</p>		<p>22868-00R</p>

ASSEMBLY TITLE:**PRODUCT DETECT ASSEMBLY****GENERAL FUNCTION:**

The product detect signal is used to trigger the labeling cycle. Optimum placement and setup of the product detect sensor is critical to accurate and repeatable label placement.

SETUP AND ADJUSTMENTS:

Set the position of the product detect sensor at a point up-stream of the peel plate area. Set the vertical position of the sensor at a point on the product that provides a stable and repeatable sense area. Loosen the vertical adjustment knobs to move the assembly along the vertical axis.

Follow the manufactures data sheet for a particular set and calibration.

MAINTENANCE:

No scheduled maintenance is required for this assembly. Always keep the drive areas free of label flash and debris.

CAUTION: Before performing any maintenance or cleaning make sure the system is powered down.

TROUBLESHOOTING:**PROBLEM:**

- No label trigger or intermittent trigger.

WHAT TO DO:

- Product does not intersect sensor scan field. Adjust sensor position until sensor detects product.
- Sensor gain set is too low. Increase gain until sensor indicator displays ON status(with product in sensor field).

ITEM	QTY	PART NO.	DESCRIPTION	PARENT ITEM
1	1	202192-002	CLEAR PRODUCT SENSOR	21560-012
2	1	203160-000	REFLECTOR	21560-012
3	1	252019-000	4 PIN MALE CONNECTOR	21560-012
4	2	A20875-000	RETAINER BLOCK, CONV. RAIL	21560-012
5	2	A20876-000	RETAINER BLOCK	21560-012
6	1	A24278-000	SENSOR MTG. SHAFT	21560-012
7	1	A24279-000	REFLECTOR MTG. SHAFT	21560-012

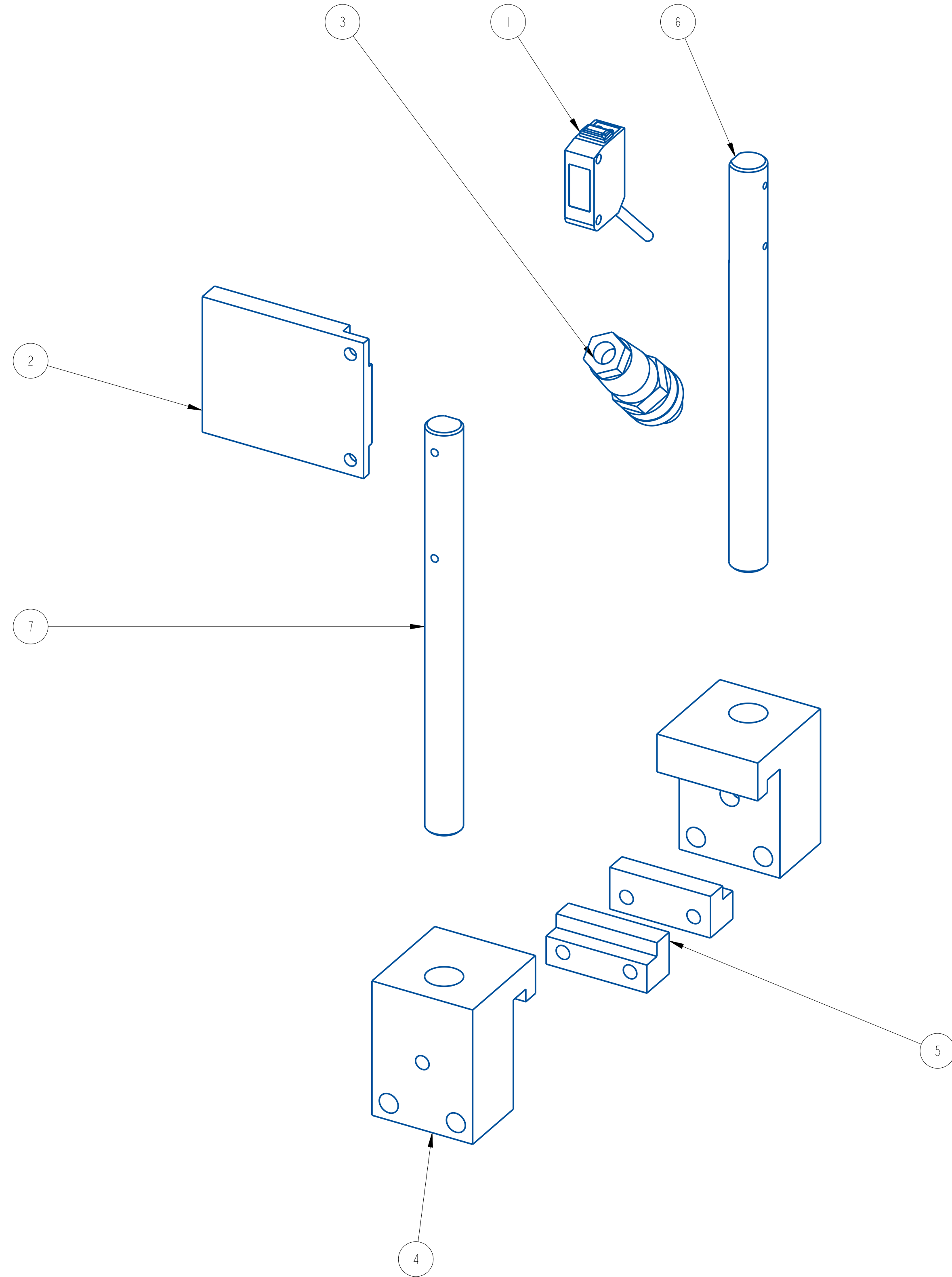

REV	DATE	DESCRIPTION	BY
A	07/18/2024	NEW DRAWING	SEM

THIS IS A PRO-ENGINEER DOCUMENT AND MAY NOT BE MODIFIED MANUALLY

UNLESS OTHERWISE SPECIFIED DIMENSIONAL TOLERANCE X ± .1 XX ± .01 XXX ± .005 ANGLES ± 30° SURFACE FINISH 125 BREAK ALL EDGES .005/.015 CORNER RADIUS .010/.030	QUADREL LABELING SYSTEMS 7670 JENTHER DRIVE MENTOR, OHIO 44060 (440) 602-4700		SCALE: 1/1 DATE: 07/18/2024 DRW BY: SEM CHK BY: 07/18/2024-SEM APPR BY:
	CLEAR PRODUCT DETECT, PNP		
MAT'L	21560-002		21560-012

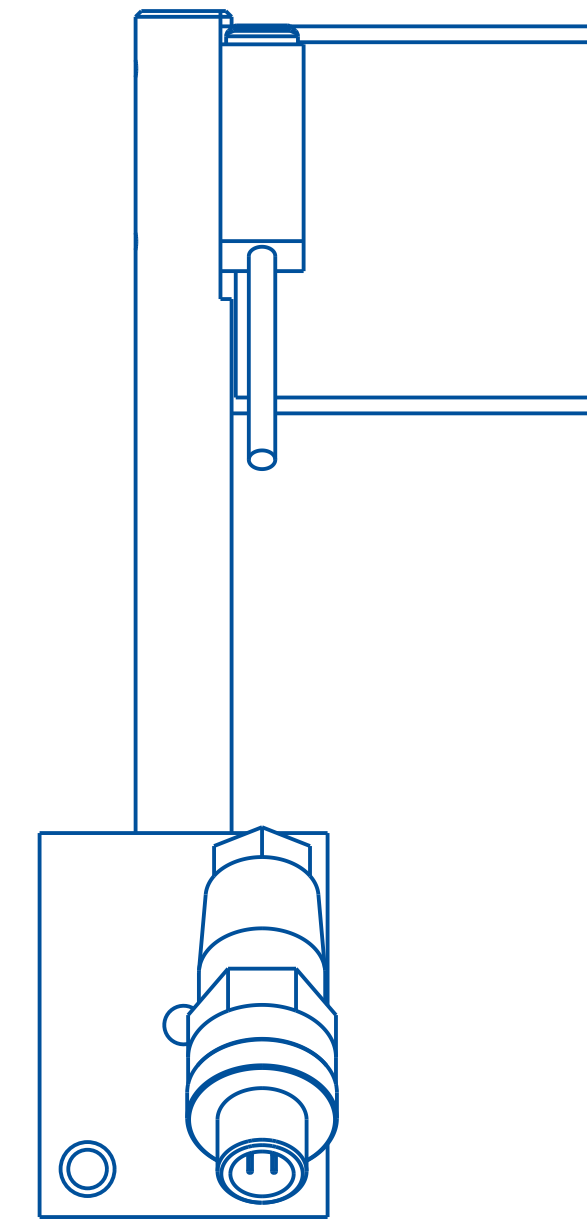
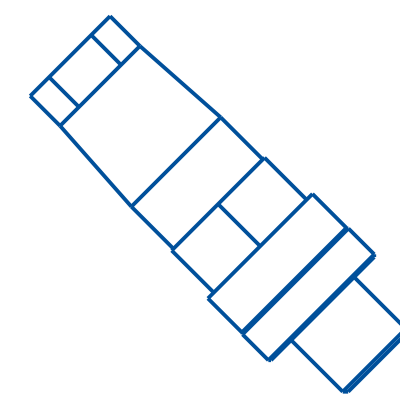
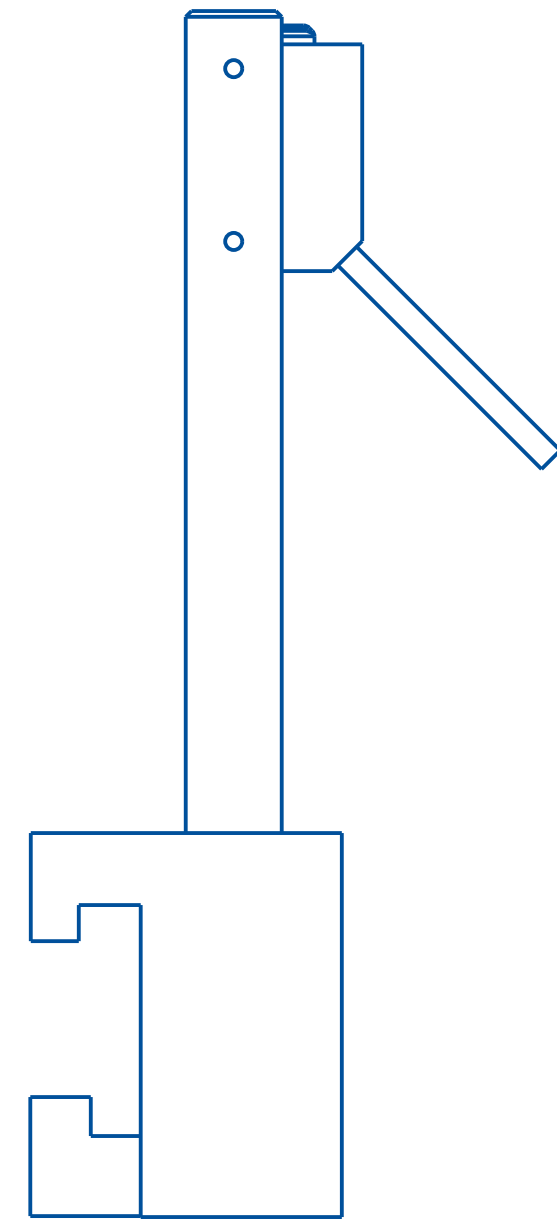
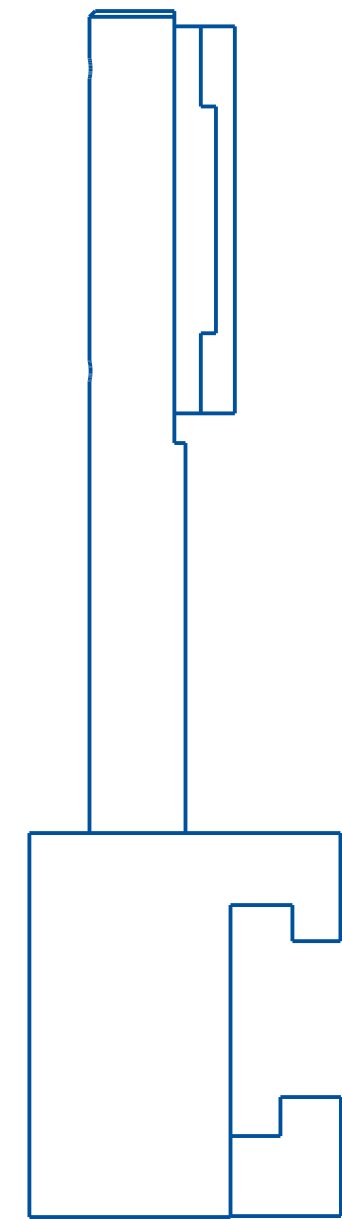
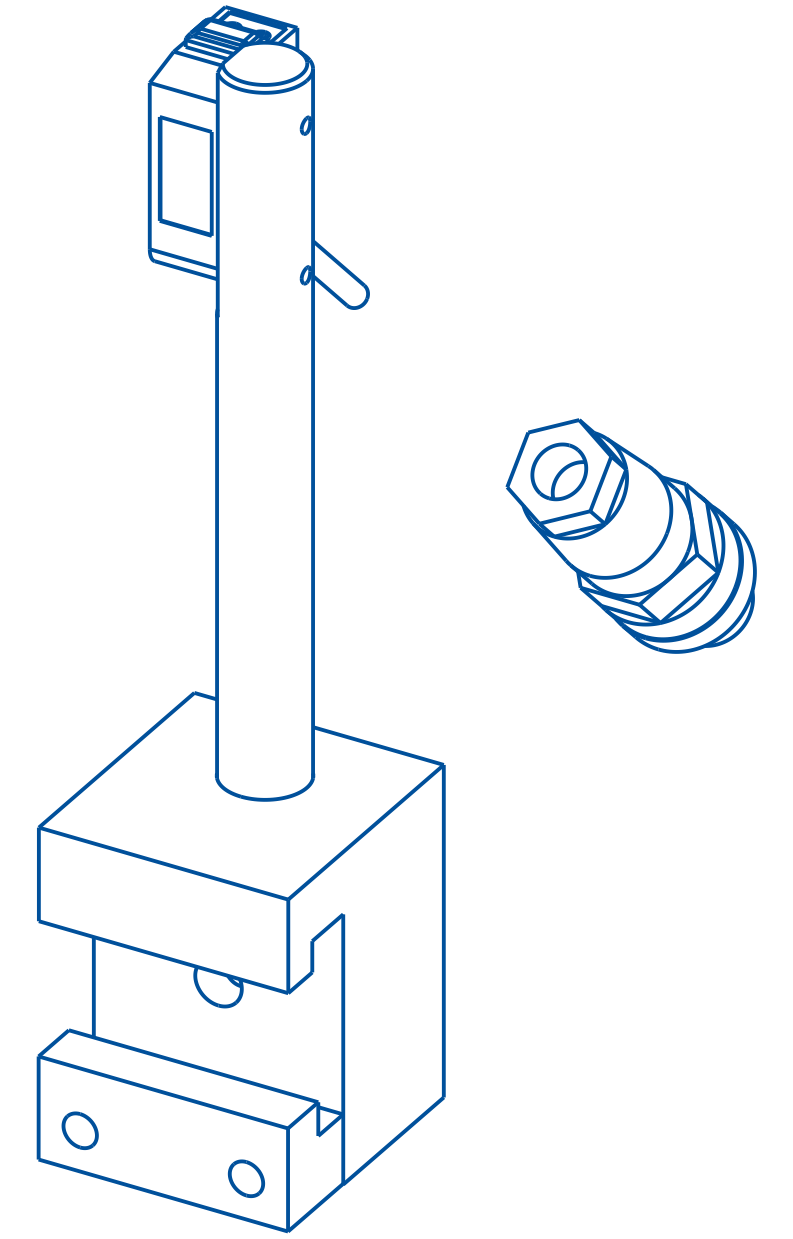
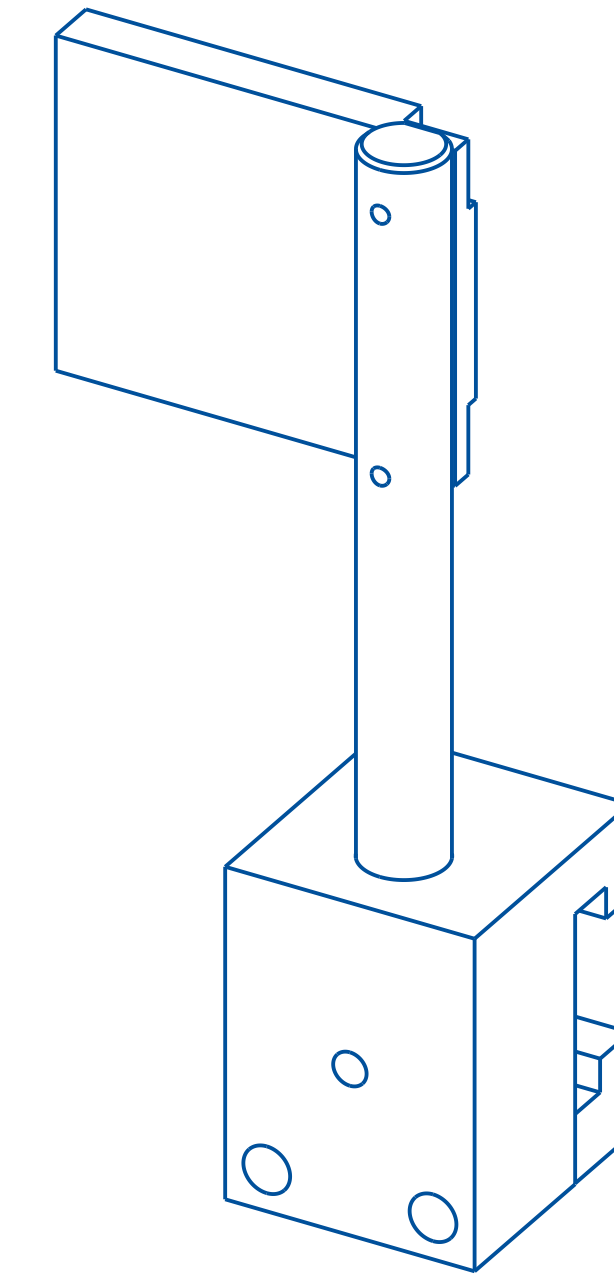
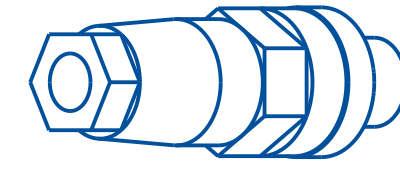
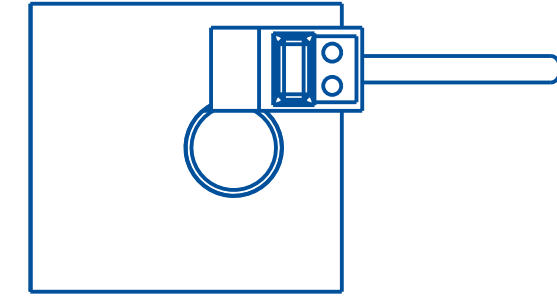
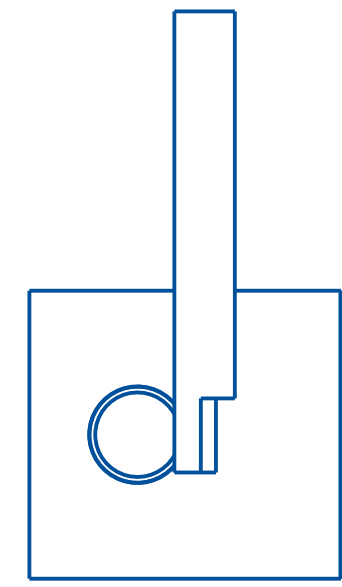

REV	DATE	DESCRIPTION	BY
A	07/18/2024	NEW DRAWING	SEM

THIS IS A PRO-ENGINEER DOCUMENT AND MAY NOT BE MODIFIED MANUALLY

UNLESS OTHERWISE SPECIFIED
DIMENSIONAL TOLERANCE

X ± .1
XX ± .01
XXX ± .005
ANGLES ± .30°

SURFACE FINISH 125
BREAK ALL EDGES .005/ .015
CORNER RADIUS .010/ .030
ALL ANGLES ARE 90°

QUADREL LABELING SYSTEMS
7670 JENTHER DRIVE
MENTOR, OHIO 44060
(440) 602-4700

SCALE: 1/1
DATE: 07/18/2024
DRW BY: SEM
CHK BY: 07/18/2024-SEM
APPR BY:

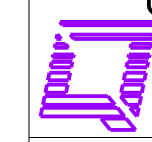

CLEAR PRODUCT DETECT, PNP

MAT'L	21560-002	21560-012
-------	-----------	-----------

PZ-G Series

Instruction Manual

Read this manual thoroughly before using the product.
Keep this manual readily available for future reference.

96M11227



Safety precautions

- Avoid running the PZ-G cable along with power and high voltage lines, as this may cause interference and/or permanent damage.
- When using a commercially available switching regulator, ground its chassis grounding and earth grounding terminals.
- Do not use in locations where direct ambient light or external light directly shines on the light receiving surface.
- With retro-reflective type sensors, when detecting highly reflective materials (such as mirrored surfaces), stabilization may be difficult. To correct this, change the angle of the sensor head, or adjust the sensitivity.
- Avoid using power which exceeds the specifications for ripple (10% max)
- Avoid using excess force when rotating the operation mode selector switch (Light-on, Dark-on) and the sensitivity adjustment trimmer.
- This product is just intended to detect the object(s). Do not use this product for the purpose to protect a human body or a part of human body.
- This product is not intended for use as explosion-proof product. Do not use this product in a hazardous location and/or potentially explosive atmosphere.

Precautions on Regulations and Standards

UL Certificate

This product is an UL/C-UL Listed product.

- UL File No. E301717
- Category NRKH,NRKH7
- Enclosure Type 1 (Based on UL50)

Be sure to consider the following specifications when using this product as an UL/C-UL Listed Product.

- Use the power supply with Class 2 output defined in NFPA70 (NEC: National Electrical Code).
- Power supply/ Control input/ Control output circuits shall be connected to a single Class 2 source only.
- Use with the over current protection device which is rated 30V or more and not more than 1A.

Part Names

PZ-G5xN/G5xP

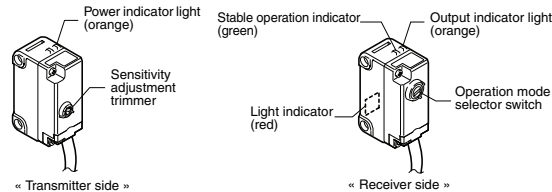

PZ-G5xB

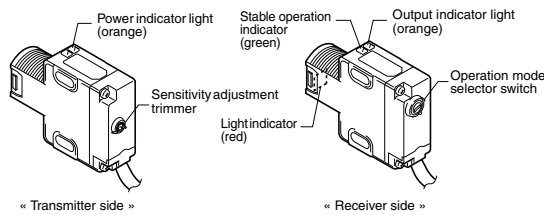

PZ-G4xN/G4xP/G10xN/G10xP/G6xN/G6xP

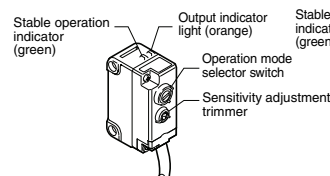

PZ-G4xB/G10xB/G6xB

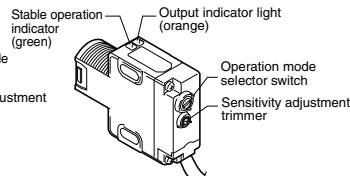

* The model name with "C" (PZ-GxxCx) is the connector type, and the model name with "E" (PZ-GxxEx) is the pigtail quick disconnect type.

Mounting Method

Side Mounting (Prepare M3 screws)

Tightening torque: 0.5 N·m or less

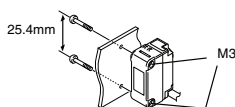

Tightening torque: 0.5 N·m or less

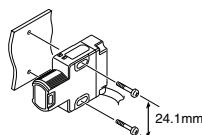

Mounting with the M18 nut (includes nut type)

The M18 nut is also available separately as OP-84225 (2 pcs. supplied).
Tightening torque: 1.0 N·m or less

Panel (5 mm or less)

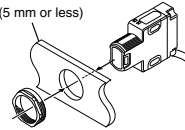

Panel cut size

$\phi 18.5 \pm 0.2$ mm

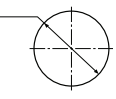

Note

- Mount the M18 nut (supplied) straight in. If mounted at an angle it cannot be tightened properly.
- When tightening the M18 nut (supplied), firmly hold the main body down. The case of the main body may be damaged if held in place with a tool such as pliers.
- When tightening the M18 nut (supplied), if excess force is applied to the nut with a tool such as pliers, it may bend it out of shape. Therefore, do not apply excess force.

Sensitivity Adjustment Method

Caution



Avoid using excess force when rotating the sensitivity adjustment trimmer and operation mode selector switch as it may cause damage.

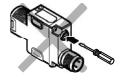

Operation mode selector switch

With the operation mode selector switch, you can select either the LIGHT-ON mode (L) or the DARK-ON (D) mode.



Reflective type (PZ-G41/G42/G101/G102/G10R/G10G/G10B Series)

The following assumes LIGHT-ON (L) is set.

Sequence	Adjustment method	Sensitivity adjustment trimmer
①	Position target in place. Slowly rotate the sensitivity trimmer from the MIN position towards the MAX position until the (orange) output indicator turns on (Position "A"). If the output indicator does not turn off, even at MIN, then MIN is considered Position "A".	
②	Remove the target. Adjust the sensitivity trimmer from MIN towards MAX until the (orange) output indicator turns on (Position "B"). If the output indicator does not light up, the MAX position is considered Position "B".	
③	Adjust the sensitivity trimmer to the midpoint between "A" and "B". Verify that the (green) stable operation light turns on with and without a target in place.	

Reference To use the sensor in DARK-ON mode, adjust the mode selector switch to "D".

Thrubeam type (PZ-G51/G52 Series) / Retro-reflective type (PZ-G61/G62 Series)

The following assumes DARK-ON (D) is set.

Sequence	Adjustment method	Sensitivity adjustment trimmer
①	Remove the target. Adjust the sensitivity trimmer to MAX. Mount the sensor heads in place so the (orange) output indicator turns off (on thrubeam models, the red light on the receiver face will turn on)	
②	Position target in place. Verify that the orange output indicator turns on (on thrubeam models, the red light on the receiver face will turn off). Adjust sensitivity lower if the output indicator does not turn on (or if the red light on the receiver face does not turn off on thrubeam models)	

Reference To use the sensor in LIGHT-ON mode, adjust the mode selector switch to "L".

I/O Circuit Diagram

PZ-G5xN/G5xP/G5xB (Transmitter side)

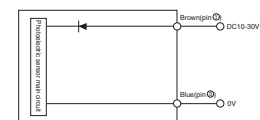

PZ-G5xN (Receiver side)/ G4xN/G10xN/G6xN

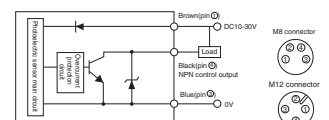

PZ-G5xP (Receiver side)/ G4xP/G10xP/G6xP

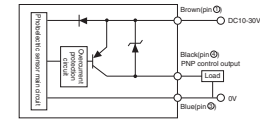

PZ-G5xB (Receiver side)/ G4xB/G10xB/G6xB

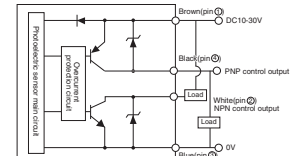

* The pin numbers represent those of the connector type / pigtail quick disconnect type. The model name with "C" (PZ-GxxCx) is the connector type, and the model name with "E" (PZ-GxxEx) is the pigtail quick disconnect type.

[PZ-GxxCN/GxxCP..... M8 connector
PZ-GxxCB/GxxEN/GxxEP..... M12 connector]

Indicators

The following describes each ON/OFF condition of indicator when LIGHT-ON (L) is set.

Reference When the DARK-ON (D) is set, the output indicator ON/OFF will reverse.

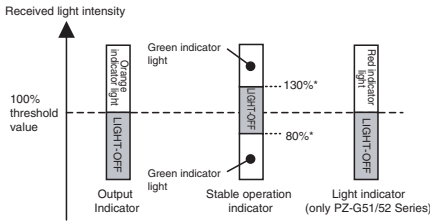

* For PZ-G62, the upper limit is 107% and the lower limit is 93%.

If the stable operation indicator turns off during operation, readjust or fine-adjust the sensitivity.

Mutual interference

- For reflective type / retro-reflective type sensors, mutual interference protection can be set for up to 2 units. However, when the sensors are mounted facing each other, change the angle of the sensor head to prevent light being emitted into each unit. (The mark detection type does not include the mutual interference function.)
- Mutual interference prevention can be set when mounting a polarizing filter attachment (optional with thru-beam type sensors) (If operation is unstable even after mounting the polarizing filter, slightly lower the sensitivity.)
- For more detailed information about mutual interference or attachment, see the PZ-G Series catalog or contact your nearest KEYENCE office.

Specifications

Type		Thru-beam		Reflective				Retro-reflective		Mark detection				
Configuration	Cable shape	Output mode	Normal	High-power	Diffuse-reflective Long-detecting distance	Diffuse-reflective Short-detecting distance	Narrow-view reflective	Definite reflective	Long detecting distance (with P.R.O. function)	Transparent target detection (without P.R.O. function)	Red	Green	Blue	
Rectangular	Cable	NPN	PZ-G51N	PZ-G52N	PZ-G41N	PZ-G42N	PZ-G101N	PZ-G102N	PZ-G61N	PZ-G62N				
		PNP	PZ-G51P	PZ-G52P	PZ-G41P	PZ-G42P	PZ-G101P	PZ-G102P	PZ-G61P	PZ-G62P				
	M8 connector	NPN	PZ-G51CN	PZ-G52CN	PZ-G41CN	PZ-G42CN	PZ-G101CN	PZ-G102CN	PZ-G61CN	PZ-G62CN	PZ-G10RCN	PZ-G10GCN	PZ-G10BCN	
		PNP	PZ-G51CP	PZ-G52CP	PZ-G41CP	PZ-G42CP	PZ-G101CP	PZ-G102CP	PZ-G61CP	PZ-G62CP	PZ-G10RCP	PZ-G10GCP	PZ-G10BCP	
Nut	Cable	NPN	PZ-G51EN	PZ-G52EN	PZ-G41EN	PZ-G42EN	PZ-G101EN	PZ-G102EN	PZ-G61EN	PZ-G62EN				
		PNP	PZ-G51EP	PZ-G52EP	PZ-G41EP	PZ-G42EP	PZ-G101EP	PZ-G102EP	PZ-G61EP	PZ-G62EP				
Nut	M12 connector	Bipolar	PZ-G51B	PZ-G52B	PZ-G41B	PZ-G42B	PZ-G101B	PZ-G102B	PZ-G61B	PZ-G62B				
		(NPN+PNP)	PZ-G51CB	PZ-G52CB	PZ-G41CB	PZ-G42CB	PZ-G101CB	PZ-G102CB	PZ-G61CB	PZ-G62CB				
Detecting distance ¹			20 m	40 m	1 m (30 x 30 cm white mat paper)	300 mm (10 x 10 cm white mat paper)	200 mm	5 to 45 mm	0.1 to 4.2 m (when R-2L reflector is used)	0.1 to 1 m (when R-2L reflector is used)	8 to 15 mm			
Spot diameter			-	-	-	-	Approx. φ 5 mm (when the detecting distance is 100 mm)	Approx. φ 2 mm (when the detecting distance is 40 mm)	-	-	Approx. 1.5 x 4 mm (when the detecting distance is 10 mm)			
Light source (LED)			Red LED	Infrared LED x 2	Red LED				Infrared LED		Red LED	Green LED	Blue LED	
Sensitivity adjustment		1-turn trimmer (230 degrees)												
Response time		500 μs										50 μs		
Operation mode		LIGHT-ON/DARK-ON, trimmer-selectable												
Indicator (LED)		Transmitter: power (orange) Receiver: output (orange), stable operation (green), light (red)			Output (orange), stable operation (green)									
Control output		Open-collector 100 mA max. (30 V max.), Residual voltage 1 V max.												
Protection circuit		Reverse-polarity protection, over-current protection, output surge absorber												
Ratings	Power voltage	10 to 30 VDC, Ripple (P-P): ±10% max, Class 2.												
	Current consumption	Transmitter: 20 mA max. Receiver: 28 mA max.	Transmitter: 25 mA max. Receiver: 28 mA max.	34 mA max.										
Environmental resistance	Enclosure rating	IEC/JEM: IP67 / NEMA: 4X, 6, 12 / DIN: IP69K												
	Ambient light	Incandescent lamp: 5,000 (lx) max, Sunlight: 20,000 (lx) max.												
	Ambient temperature	-20 °C to +55 °C (No freezing)												
	Relative humidity	35 to 85 % RH (No condensation)												
	Vibration resistance	10 to 55 Hz, 1.5 mm double amplitude in X, Y, Z directions, 2 hours each												
Shock resistance	1000 m/s ² in X, Y, Z directions, 6 times each													
Interference prevention		2 units (when polarizing filter attachment is used)		2 units (with the automatic different cycle function)										
Material		Case, M18 nut (nut type only): reinforced glass polybutylene terephthalate (PBT), Trimmer: reinforced glass polyamide (PA) Cable (Cable type / pigtail quick disconnect type only): Polyvinyl chloride (PVC), Screw (Case connection): Steel, zinc-nickel plated, Packing (Case connection): Nitrile-butadiene rubber (NBR) Connector (pigtail quick disconnect type only): Brass-nickel plated, Polybutylene terephthalate (PBT), Polyvinyl chloride (PVC)												
Lens cover		Polyarylate (PAR)				Acrylic plastic (PMMA)			Polyarylate (PAR)					
Tightening torque		Rectangular type (side screw part): 0.5 N·m max. Nut type (front M18 part): 1.0 N·m max., (side slot part): 0.5 N·m max.												
Accessory ²		Instruction manual, M18 nut x 2 (nut thru-beam type), M18 nut x 1 (other nut types)												
Weight		Rectangular cable type: Approx. 60 g (Approx. 50 g for thru-beam transmitter), Rectangular M8 connector type: Approx. 10 g, rectangular M12 pigtail quick disconnect type: Approx. 30 g Nut type cable type: Approx. 65 g (Approx. 55 g for thru-beam transmitter), Nut type M12 connector type: Approx. 15 g												

¹ The detection distance is measured with the maximum sensitivity.

² The cable for the connector type / pigtail quick disconnect type is sold separately. The reflector for the retro-reflective type is sold separately.

WARRANTY

KEYENCE products are strictly factory-inspected. However, in the event of a failure, contact your nearest KEYENCE office with details of the failure.

1. WARRANTY PERIOD

The warranty period shall be for one year from the date that the product has been delivered to the location specified by the purchaser.

2. WARRANTY SCOPE

(1) If a failure attributable to KEYENCE occurs within the abovementioned warranty period, we will repair the product, free of charge. However, the following cases shall be excluded from the warranty scope.

- Any failure resulting from improper conditions, improper environments, improper handling, or improper usage other than described in the instruction manual, the user's manual, or the specifications specifically arranged between the purchaser and KEYENCE.
- Any failure resulting from factors other than a defect of our product, such as the purchaser's equipment or the design of the purchaser's software.
- Any failure resulting from modifications or repairs carried out by any person other than KEYENCE staff.
- Any failure that can certainly be prevented when the expendable part(s) is maintained or replaced correctly as described in the instruction manual, the user's manual, etc.
- Any failure caused by a factor that cannot be foreseen at a scientific/technical level at the time when the product has been shipped from KEYENCE.
- Any disaster such as fire, earthquake, and flood, or any other external factor, such as abnormal voltage, for which we are not liable.

(2) The warranty scope is limited to the extent set forth in item (1), and KEYENCE assumes no liability for any purchaser's secondary damage (damage of equipment, loss of opportunities, loss of profits, etc.) or any other damage resulting from a failure of our product.

3. PRODUCT APPLICABILITY

KEYENCE products are designed and manufactured as general-purpose products for general industries.

Therefore, our products are not intended for the applications below and are not applicable to them. If, however, the purchaser consults with us in advance regarding the employment of our product, understands the specifications, ratings, and performance of the product on their own responsibility, and takes necessary safety measures, the product may be applied. In this case, the warranty scope shall be the same as above.

- Facilities where the product may greatly affect human life or property, such as nuclear power plants, aviation, railroads, ships, motor vehicles, or medical equipment
- Public utilities such as electricity, gas, or water services
- Usage outdoors, under similar conditions or in similar environments

E 1040-1

KEYENCE CORPORATION

1-3-14, Higashi-Nakajima, Higashi-Yodogawa-ku,
Osaka, 533-8555, Japan

PHONE: +81-6-6379-2211 www.keyence.com

Specifications are subject to change without notice.

A7WW1-MAN-0069

Copyright (c) 2010 KEYENCE CORPORATION. All rights reserved.

11227E 1070-1 96M11227J

Printed in Japan



7.9 CHAIN ALIGNER ASSEMBLY

7.9.1 GENERAL INFORMATION

The chain aligner assembly is an optional module that is generally placed at the entrance of the conveyor directly before the top trap assembly. Chain aligners are primarily for oval front/back applications. This assembly centers the product on the conveyor and straightens the product to ensure label accuracy. Chain aligners are controlled with AC motors and a single AC drive located in the electrical enclosure.

7.9.2 ADJUSTMENTS

The chain aligner assembly is adjusted in and out or up and down by rotating the knobs clockwise or counter clockwise. Lock the assembly in place with the ratchet handles on the front and side of the assembly.



CAUTION

Do not make any adjustments when assembly or conveyor are running. Read and understand manual before making any adjustments.



ASSEMBLY TITLE: CHAIN ALIGNERS

GENERAL FUNCTION:

-Provides product alignment before label application.

SET-UP AND ADJUSTMENTS:

-VERTICAL ADJUSTMENT: Loosen clamp lever and turn adjusting rod with ratchet handle. Tighten clamp lever when desired position is obtained.

-HORIZONTAL ADJUSTMET: loosen clamp lever and turn adjusting rod with ratchet handle. Tighten clamp lever when desired position is obtained.

MAINTENANCE:

-Clean chain aligners frequently. Grease all fittings after every forty hours of operation. Use lithium grease only.

TROUBLESHOOTING:

<u>PROBLEM</u>	<u>WHAT TO DO</u>
-Products do not align	-Adjust horizontally to increase pressure on the product.
-Products will not travel through aligners.	-Adjust horizontally to apply less pressure to the product.



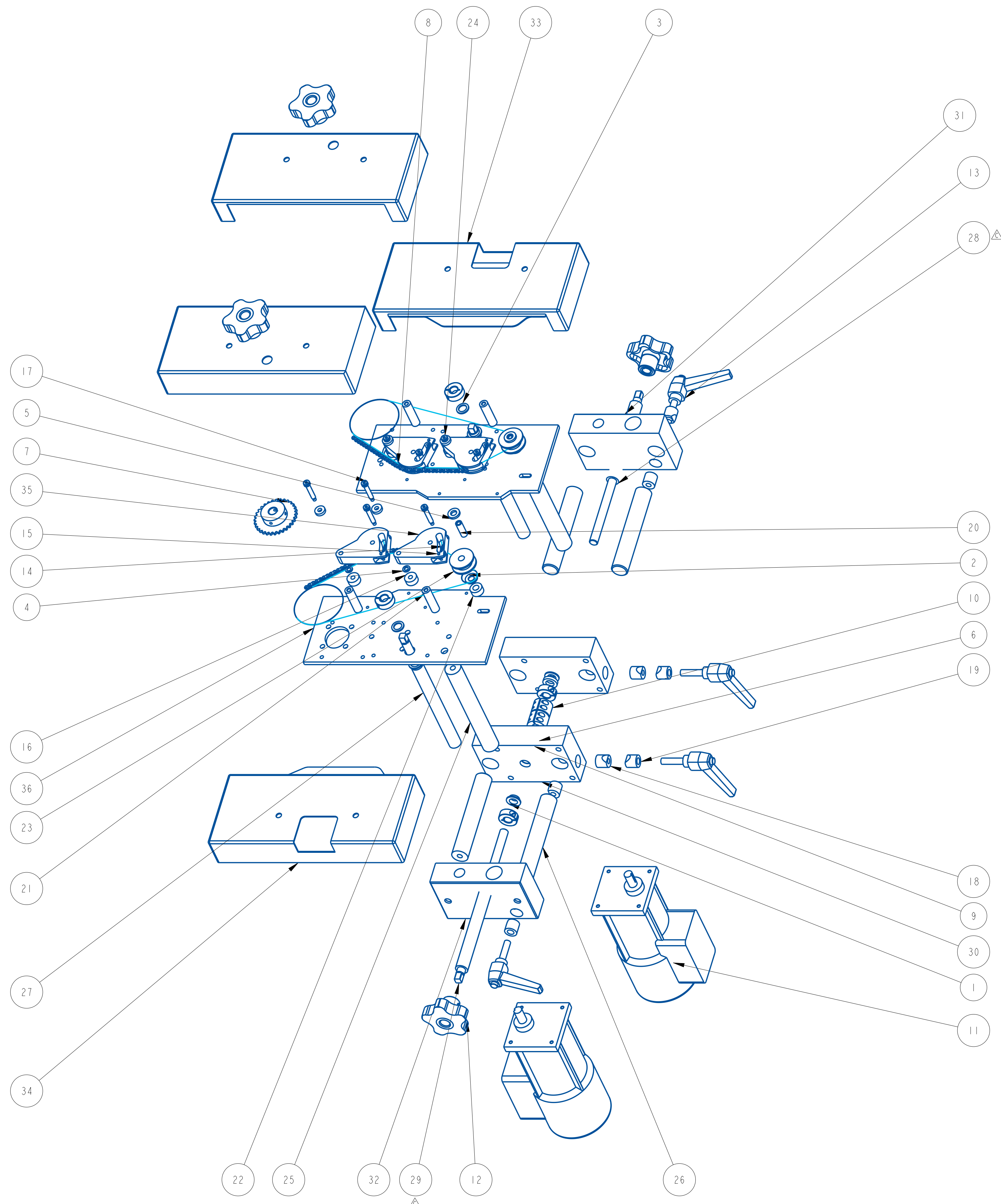

ITEM	QTY	PART NO.	DESCRIPTION	PARENT ITEM
1	6	131086-000	BEARING, FLANGE	20811-012
2	2	151003-000	BEARING, THRUST WASHER	20811-012
3	2	151004-000	BEARING, THRUST WASHER	20811-012
4	4	151013-000	BEARING, THRUST WASHER	20811-012
5	2	151021-000	BEARING, THRUST WASHER	20811-012
6	2	151050-000	BEARING, THRUST WASHER	20811-012
7	2	302052-000	SPROCKET - 25BS32HT-1/2"B-K&S	20811-012
8	2	361124-000	CHAIN, 1/4 PITCH	20811-012
9	6	361169-000	COLLAR, 1/2 IN. ID ONE-PIECE CLAMP	20811-012
10	1	361259-000	COUPLING, ONE PIECE CLAMP-ON	20811-012
11	2	413022-000	GEARMOTOR 94 RPM	20811-012
12	4	801332-000	LOBE KNOB W/ ORANGE CENTER	20811-012
13	4	801805-000	CLAMPING LEVER	20811-012
14	4	811187-000	SPRING, EXTENSION	20811-012
15	4	871116-000	ROLL PIN	20811-012
16	4	A20006-000	ROCKER ARM MOUNTING SPACER	20811-012
17	8	A20596-002	1/4 x 1-1/4 SHOULDER BOLT	20811-012
18	4	A20688-000	LOCKING CLAMP	20811-012
19	4	A20689-000	LOCKING CLAMP	20811-012
20	2	A20735-000	IDLER SHAFT	20811-012
21	4	A20736-001	GUARD SPACER	20811-012
22	2	A20737-000	IDLER SPACER	20811-012
23	2	A20738-000	IDLER PULLEY	20811-012
24	4	A20739-000	ROCKER ARM SPACER	20811-012
25	2	A21427-000	GUIDE ROD	20811-012
26	4	A21428-000	6.25" GUIDE ROD	20811-012
27	2	A21440-000	ADJUSTING SCREW	20811-012
28	1	A24656-007	ADJUSTING SCREW	20811-012
29	1	A24657-007	ADJUSTING SCREW	20811-012
30	2	A24752-011	HORIZONTAL MTG. BLOCK, CHAIN ALIGNER	20811-012
31	1	B21807-010	VERTICAL ADJUSTMENT BLOCK	20811-012
32	1	B21807-011	VERTICAL ADJUSTMENT BLOCK	20811-012
33	1	C20020-007	CHAIN ALIGNER COVER	20811-012
34	1	C20020-008	CHAIN ALIGNER COVER	20811-012
35	4	C20138-000	ROCKER ARM	20811-012
36	2	C20832-000	CHAIN ALIGNER MOUNTING PLATE	20811-012



REV	DATE	DESCRIPTION	BY
C	Oct-07-25	WAS A24657-000 & A24656-000	RDL
B	7/23/25	REVISED COVER	SEM
A	Mar-19-21	NEW DRAWING	TJS

THIS IS A PRO-ENGINEER DOCUMENT AND MAY NOT BE MODIFIED MANUALLY

UNLESS OTHERWISE SPECIFIED
 DIMENSIONAL TOLERANCE
 .XX ± .01
 .XXX ± .005
 ANGLES ± 30°

SURFACE FINISH 125
 BREAK ALL EDGES .005/0.15
 CORNER RADIUS .010/0.30

QUADREL LABELING SYSTEMS
 7670 JENTHER DRIVE
 MENTOR, OHIO 44060
 (440) 602-4700

SCALE: 9/32
 DATE: Mar-19-21
 DRW BY: TJS
 CHK BY: 03/02/24-SEM
 APPR BY:

SELF POWERED CHAIN ALIGNER ASSEMBLY

MAT'L 20811-012 20811-012

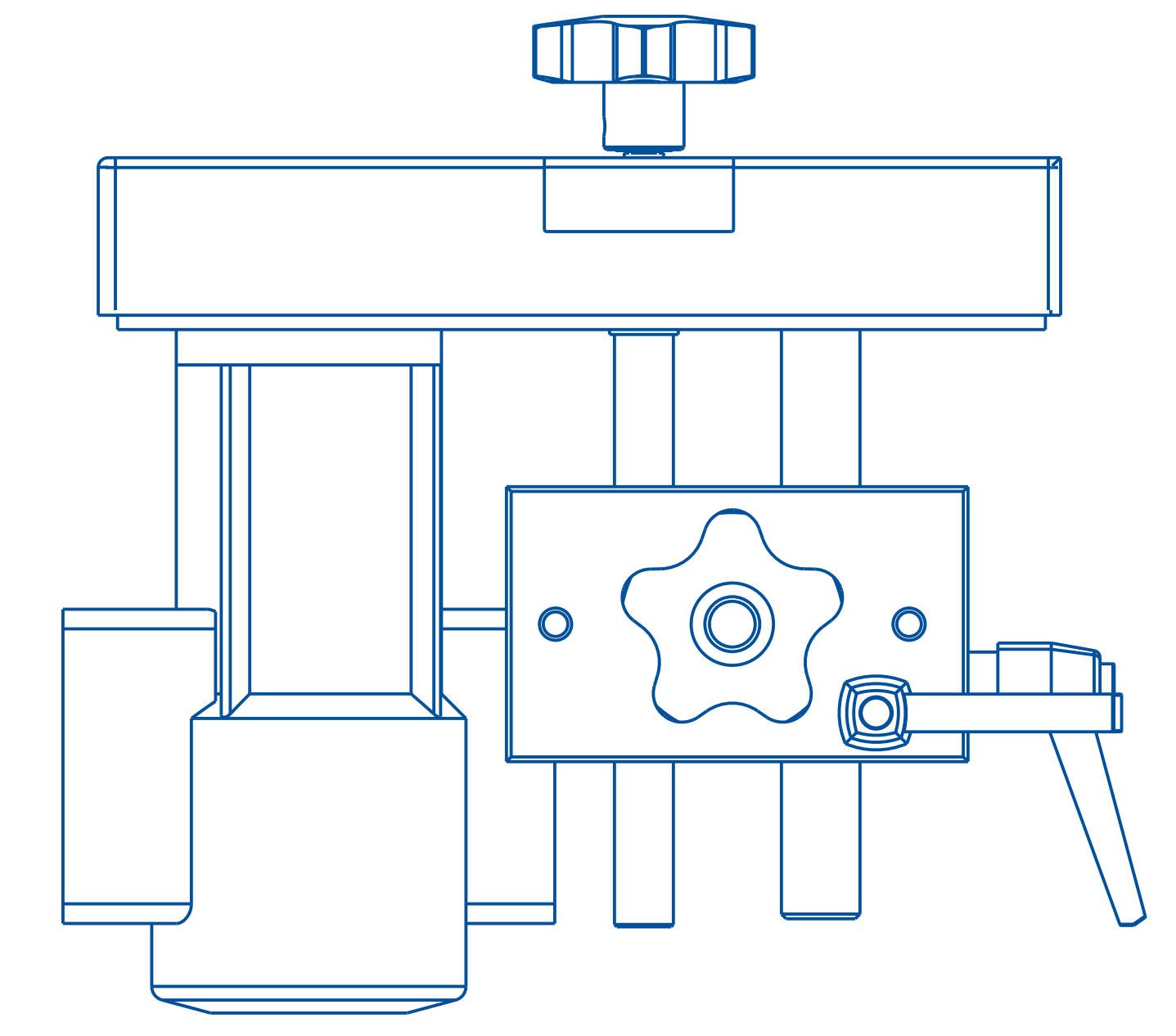
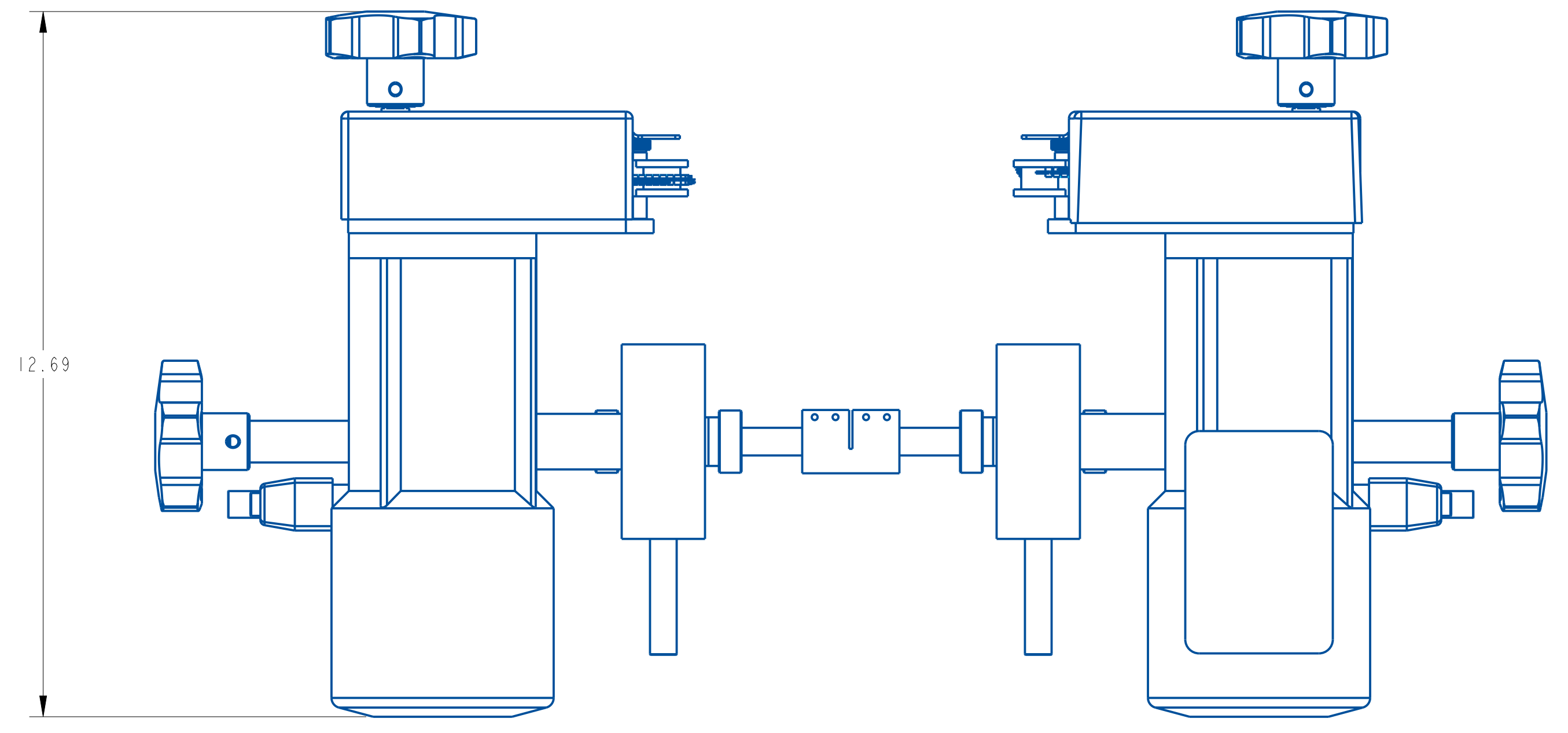
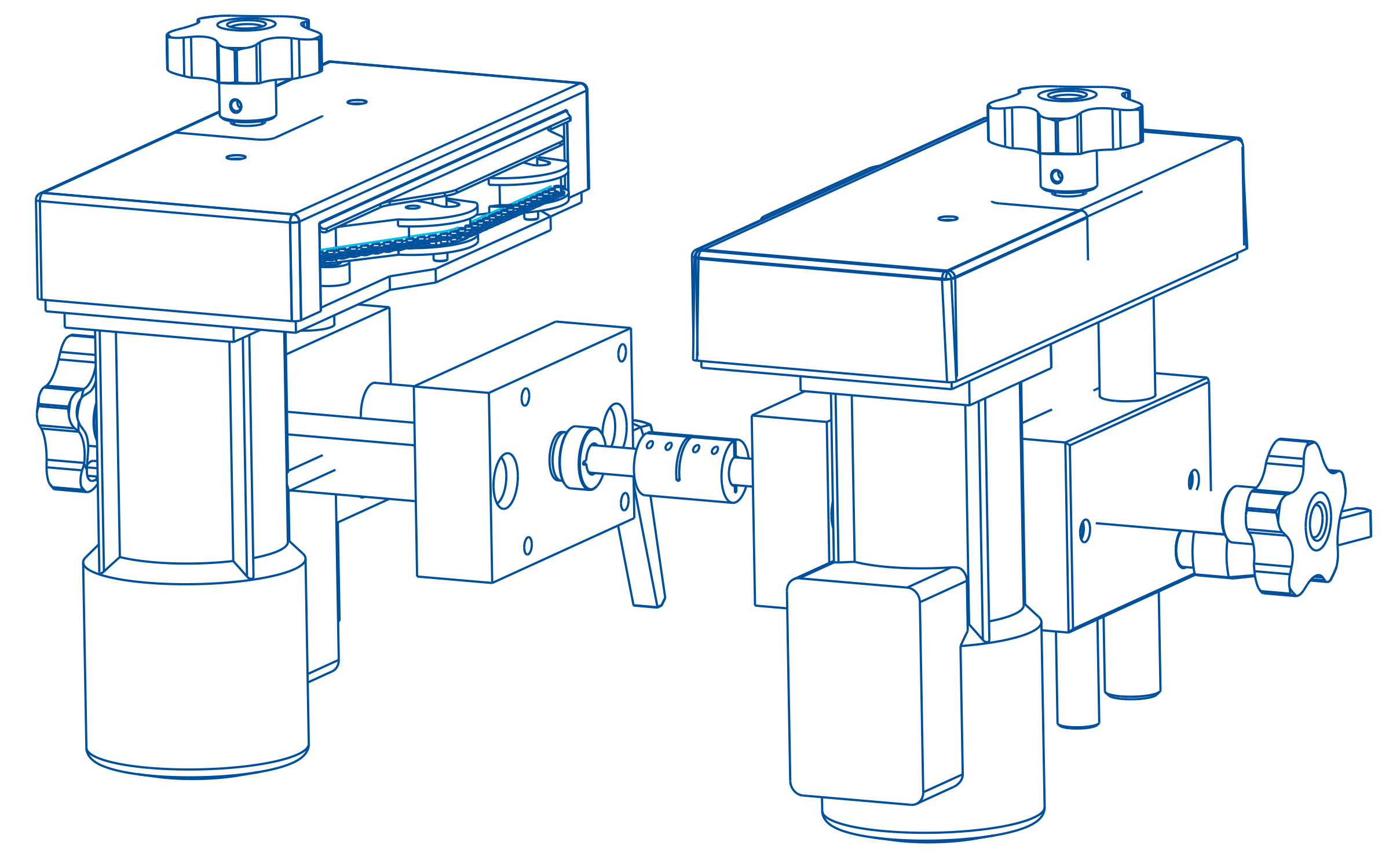
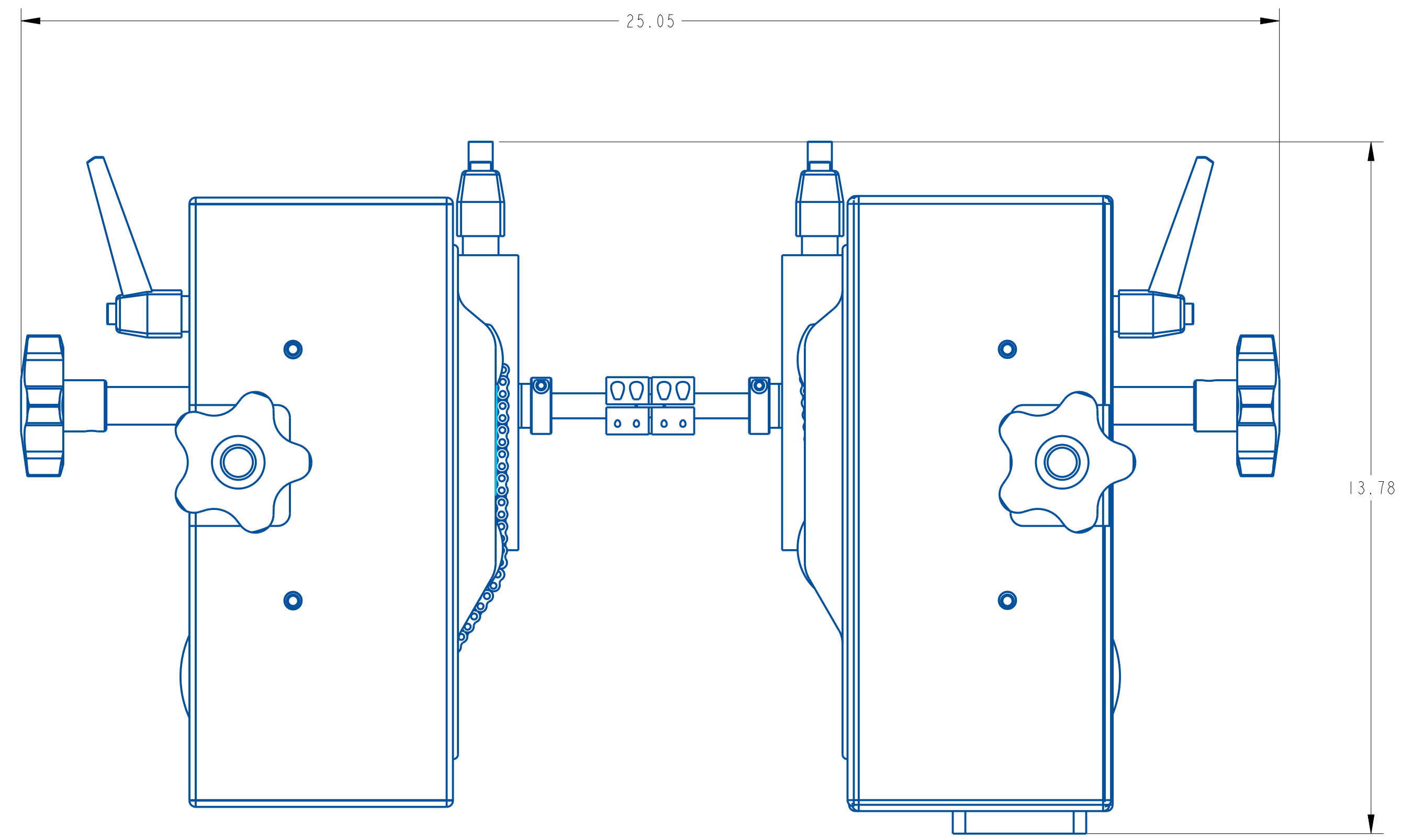

REV	DATE	DESCRIPTION	BY
C	Oct-07-25	WAS A24657-000 & A24656-000	RDL
B	7/23/25	REVISED COVER	SEM
A	Mar-19-21	NEW DRAWING	TJS

THIS IS A PRO-ENGINEER DOCUMENT AND MAY NOT BE MODIFIED MANUALLY

UNLESS OTHERWISE SPECIFIED
DIMENSIONAL TOLERANCE

xx ± .01
xxx ± .005
ANGLES ± .30°

SURFACE FINISH 125
BREAK ALL EDGES .005/0.15
CORNER RADIUS .010/0.30
ALL ANGLES ARE 90°

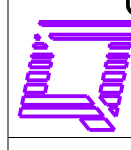

QUADREL LABELING SYSTEMS
7670 JENTHER DRIVE
MENTOR, OHIO 44060
(440) 602-4700

SCALE: 1/2
DATE: Mar-19-21
DRW BY: TJS
CHK BY: 03/02/24-SEM
APPR BY:

SELF POWERED CHAIN ALIGNER ASSEMBLY

Electronics

Econoline

--	B21820-030E	1	Enclosure, Modification
--	222360-002	1	Enclosure, Steel, 30 x 24 x 8
--	B21820-030P	1	Panel, Modification
--	222360-001	1	Panel, SCE30P24
--	241061-000	2	Fuse, 1A, 1.25 x .25
--	241053-000	2	Fuse, 3A, 1.25 x .25
--	241060-000	12	Fuse, 5A, 1.25 x .25
--	241187-000	2	Fuse, 15A, CC
--	251799-000	5	End Cap, ST1.5-4
--	251795-000	8	End Terminal
--	251798-000	2	Partition Plate, ST1.5 - 4

--	251855-000	3	2-Pole Jumper, ST1.5
--	251856-000	1	3-Pole Jumper, ST1.5
--	251859-000	2	10-Pole Jumper, ST1.5
--	251801-000	2	2-Pole Jumper, ST2.5
--	251804-000	2	5-Pole Jumper, ST2.5
--	251854-000	8	ST1.5 Ground Terminal Block
--	251853-000	50	ST1.5 Terminal Block
--	251796-000	4	ST2.5 Ground Terminal
--	251846-000	1	ST4 Ground Terminal
--	251797-000	12	ST2.5 Terminal Block

16	262821-000	1	PLC 232 Cable, 1ft
15	221720-005	1	PLC Expansion, KV-N8EXR 8 In, 8 Out
14	221717-001	1	PLC, Keyence KV-N24DTP
13	252057-000	3	RJ45 Connector
12	411458-007	4	AC Drive, Fuji Mini, 120V, 1/2 HP
12	411458-000	4	AC Drive, Fuji Mini, 220V, 1/2 HP
11	202628-000	2	Relay, 24V, SPDT
10	211528-005	1	Power Supply, 24V, 2.5A
9	412476-000	2	Stepper Drive, Applied Motion STRAC8
8	202620-000	1	Contactoraux Block, 2 NO
7	202607-000	3	Contactoraux Surge Suppressor
6	202604-000	3	Contactoraux, 24V, 4 NO
5	263824-000	1	Connector, 2 Pin, DC Inhibit
4	411457-000	1	DC Drive, Single Kit
3	251788-001	16	Fuse Holder, 300V AC, Indicating
2	272117-003	1	Disconnect, 25A Base Mount
1	241285-000	2	Fuse Holder, CC

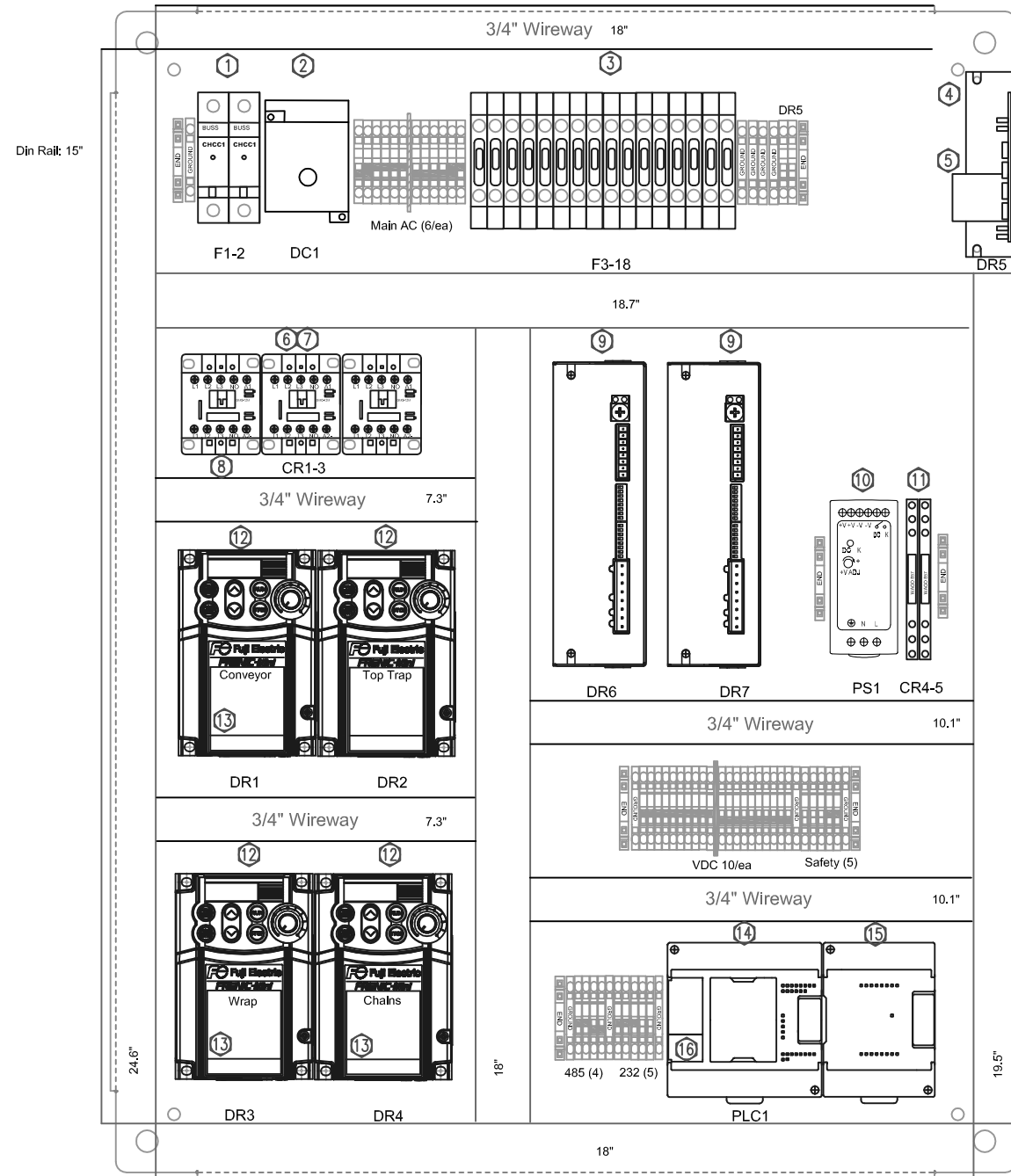

Din Rail: 3.75"

1" Wireway Unless Noted
Component Hardware: 8-32 SHCS
Wireway/Din Rail Hardware: 8-32 BHCS

Junction Box Terminals

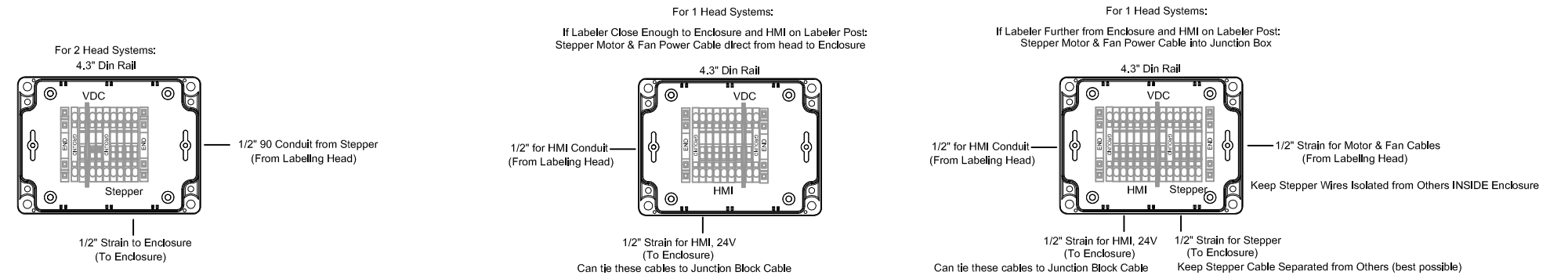

UNLESS OTHERWISE SPECIFIED	QUADREL LABELING SYSTEMS 7670 Jenther Drive Mentor, Ohio 44060 (440) 602-4700	SCALE: 1:1
DIMENSIONAL TOLERANCE		DATE: 30AUG2024
.X ± .XTOL		DRAWN BY: CAV
.XX ± .XXTOL		REVISID:
.XXX ± .XXXTOL	Layout, Econoline	
ANGLES ± ANG.TOL		
SURFACE FINISH FINISH/TOL	MAT'L	
BREAK ALL EDGES .005/.015	21820-xxx-000	B21820-037
CORNER RADIUS .010/.030		

120/220V, 1PH, 15A

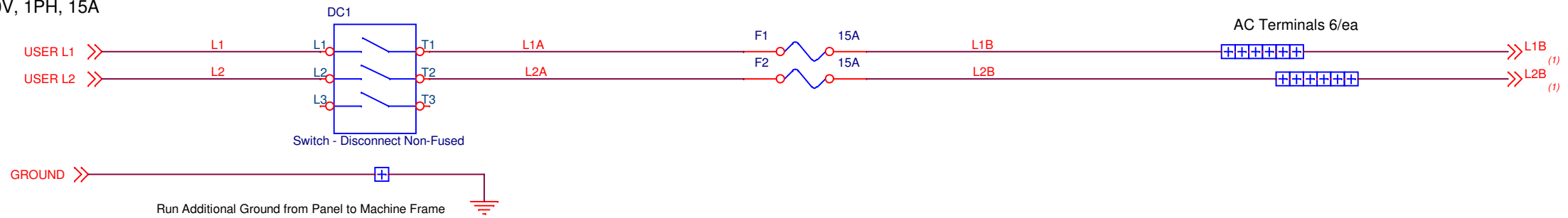

FED FROM AC TERMINAL BLOCKS

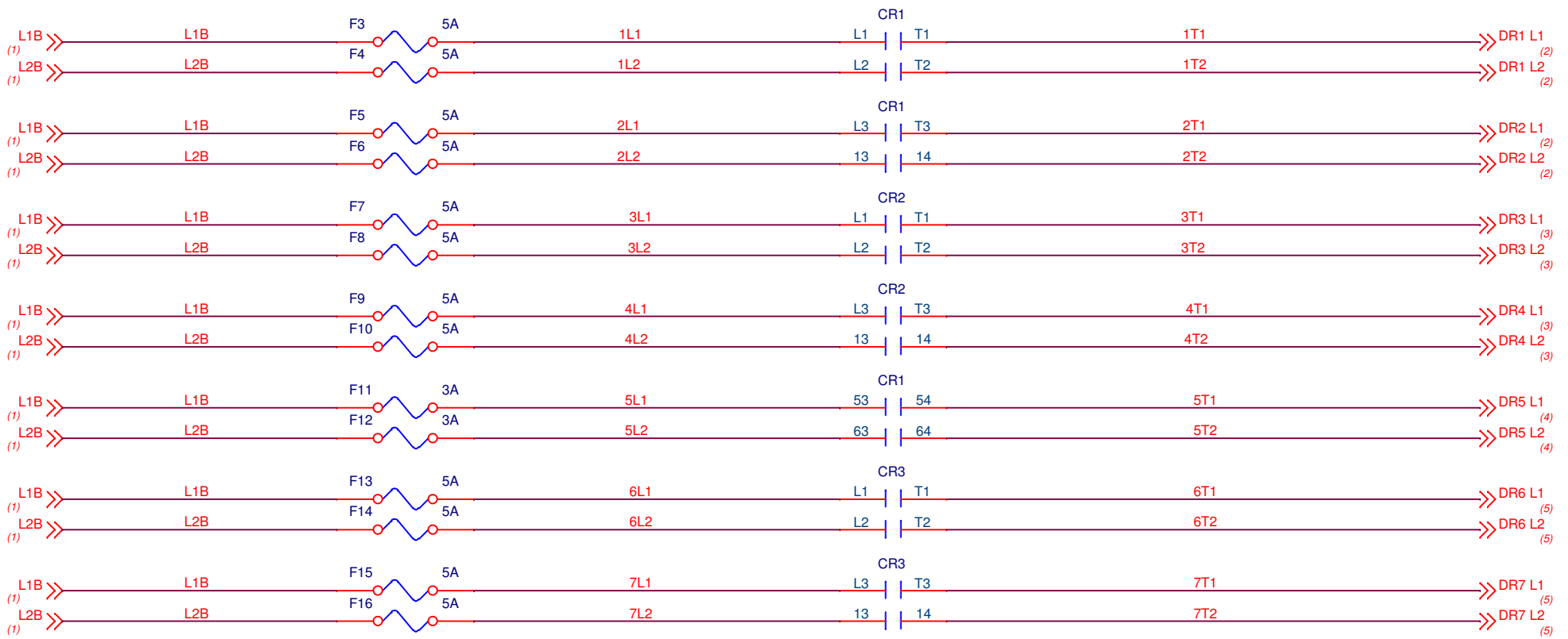

Keep Component Identifications Regardless Of Machine Configuration

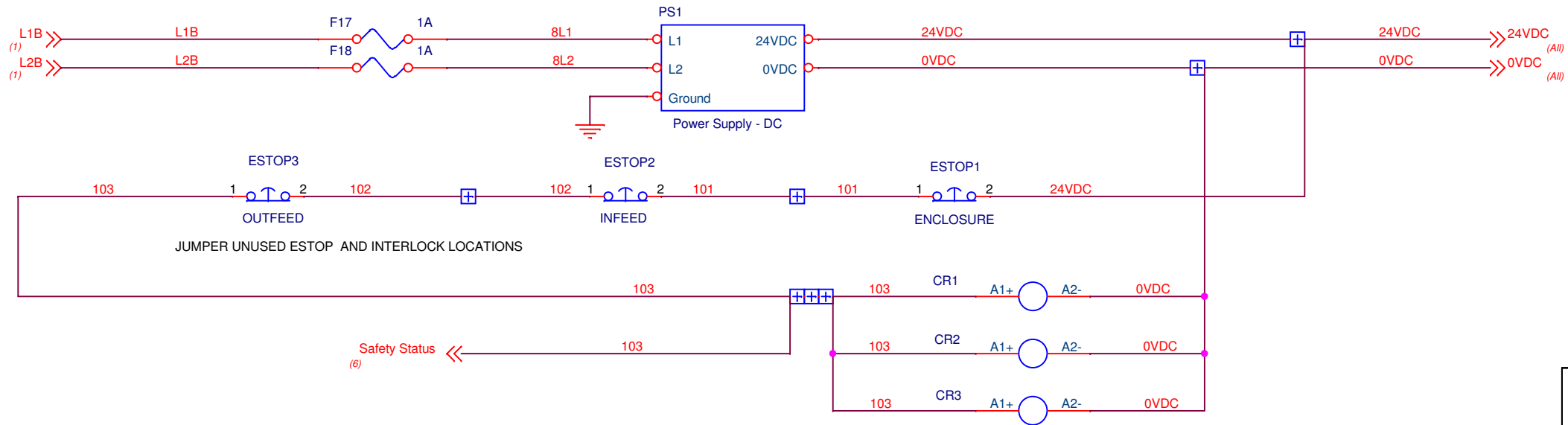

COLOR	TECHNICIAN	DATE

For Quadrel Assembly Use

WIRING (UNLESS NOTED):
AC WIRING: 14AWG BLACK
+VDC/SIGNALS: 18AWG BLUE
0VDC: 18AWG WHITE/BLUE
GROUND: 14AWG GREEN/YELLOW

QUADREL LABELING SYSTEMS 7670 JENTHER DR. MENTOR, OH 44060 Drawn By: CAV	D	Printer Relays	CAV	27AUG2025
	C	Updated Shielding	CAV	10FEB2025
	B	Hugger Options	CAV	30JAN2025
	A	Release	CAV	19NOV2024
	-	Pre Release	CAV	03SEP2024
Title		DESCRIPTION	BY	DATE
ECONOLINE				
Schematic #		SB21820-006	Rev	D
Date: Wednesday, August 27, 2025		Sheet	01 of	07

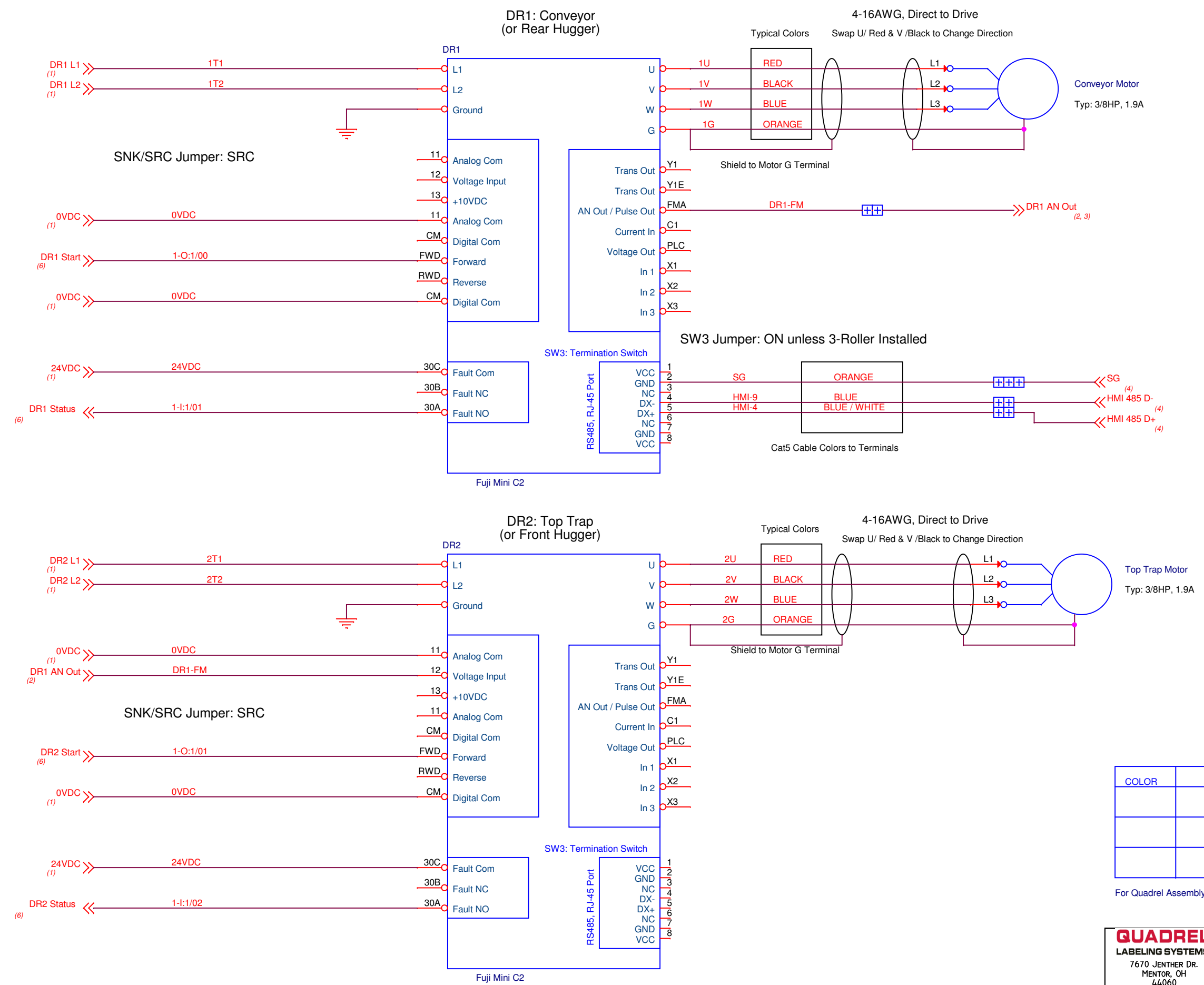

COLOR	TECHNICIAN	DATE

For Quadrel Assembly Use

QUADREL LABELING SYSTEMS
7670 JENTHER DR.
MENTOR, OH 44060

D	Printer Relays	CAV	27AUG2025
C	Updated Shielding	CAV	10FEB2025
B	Hugger Options	CAV	30JAN2025
A	Release	CAV	19NOV2024
-	Pre Release	CAV	03SEP2024

Drawn By: CAV
Title: **CONVEYOR AND TOP TRAP**
Schematic #: **SB21820-006** Rev: **D**
Date: Wednesday, August 27, 2025 | Sheet 02 of 07

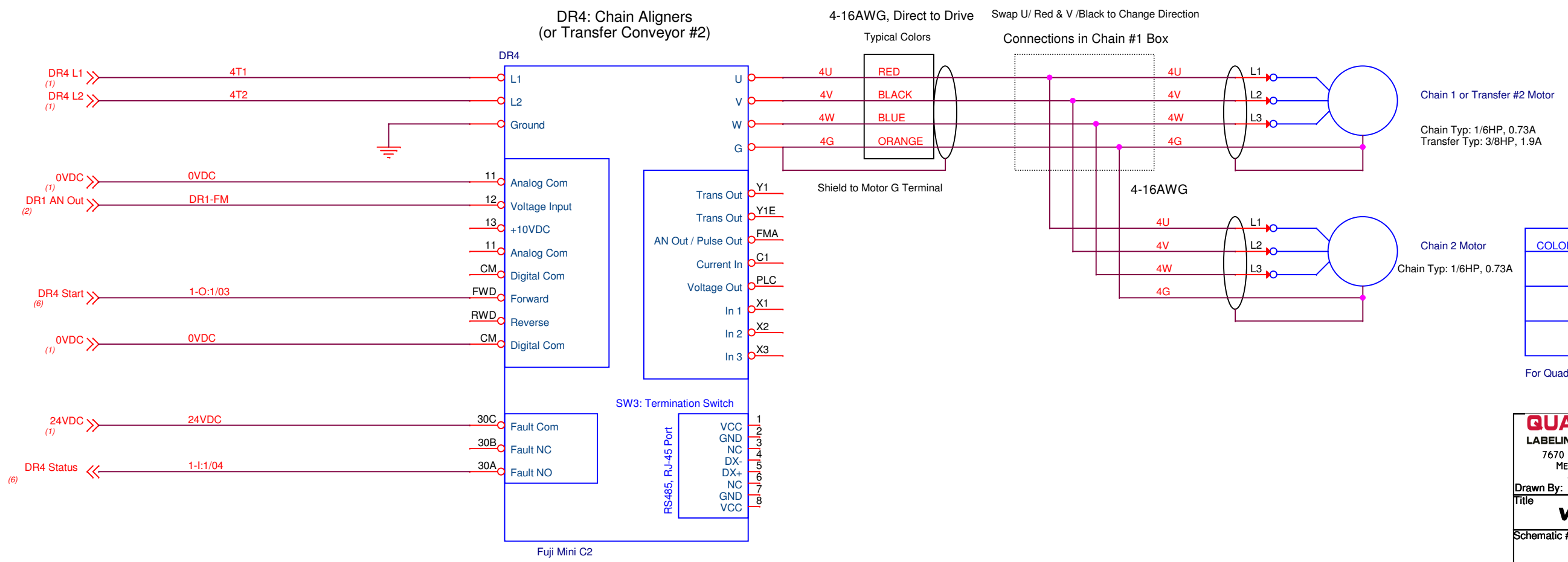
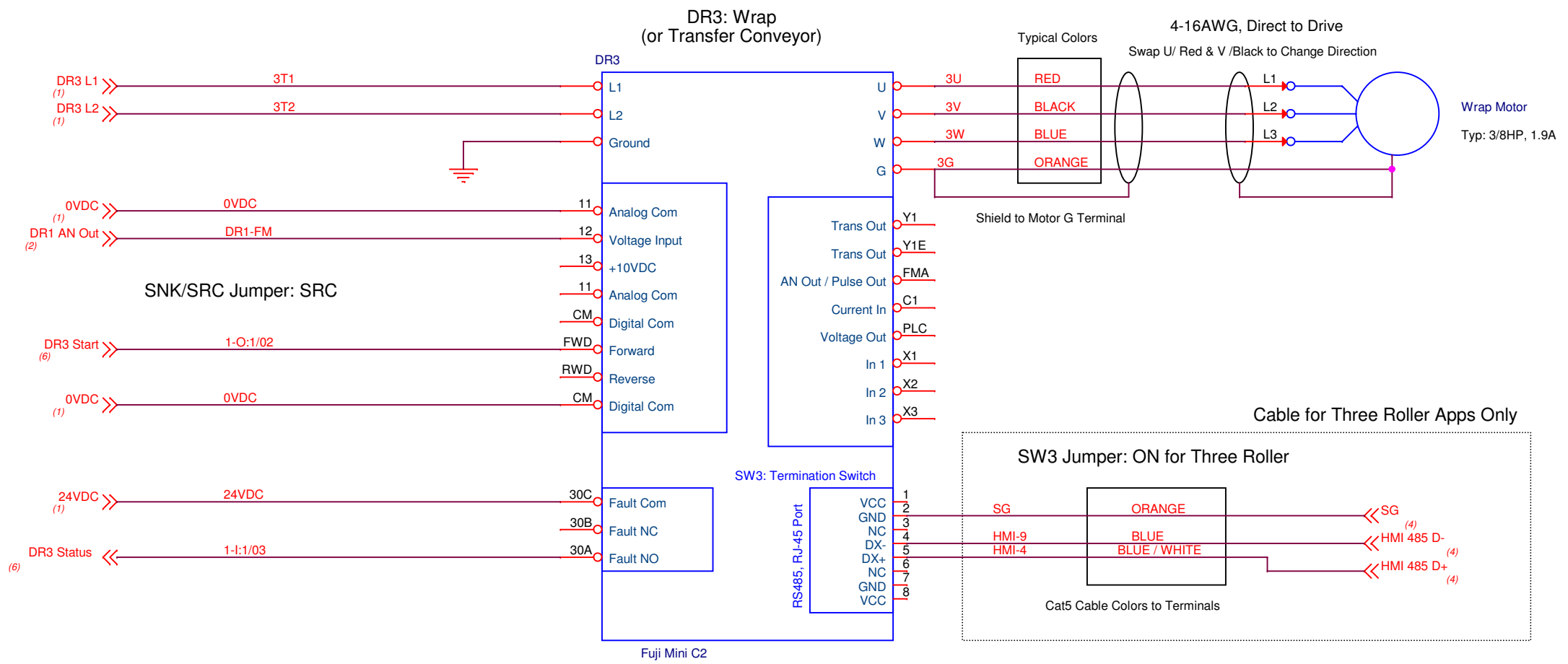

COLOR	TECHNICIAN	DATE

For Quadrel Assembly Use

QUADREL LABELING SYSTEMS
7670 JENTHER DR.
MENTOR, OH 44060

D	Printer Relays	CAV	27AUG2025
C	Updated Shielding	CAV	10FEB2025
B	Hugger Options	CAV	30JAN2025
A	Release	CAV	19NOV2024
-	Pre-Release	CAV	03SEP2024

Drawn By: CAV

Title: **WRAP, CHAIN ALIGNERS**

Schematic #: **SB21820-006** Rev **D**

Date: Wednesday, August 27, 2025 | Sheet 03 of 07

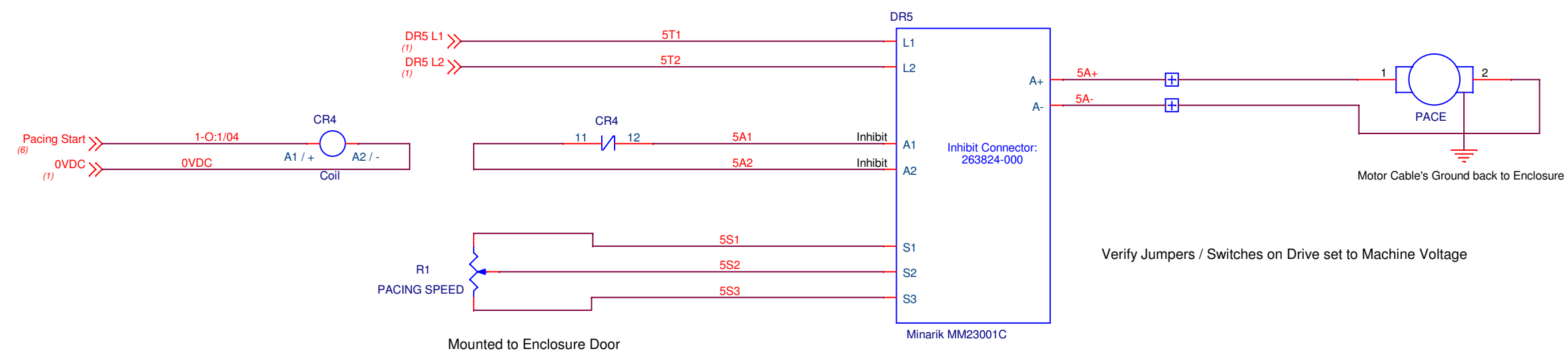

For Steel Enclosure (Mounted off of Top Trap or Adjustable Arms)

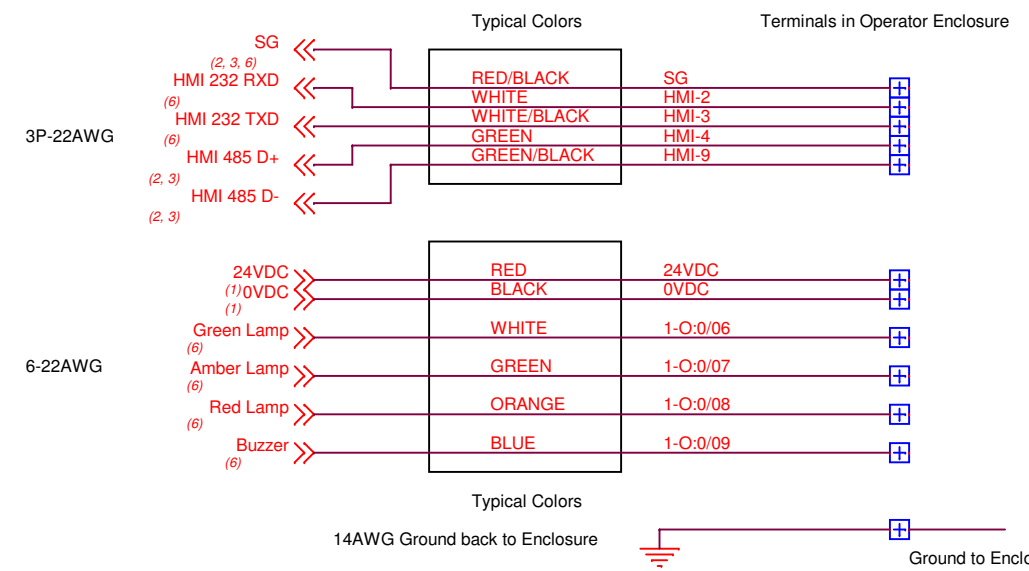

Stack Lamp Option (Would be connected to terminals when sold & installed)

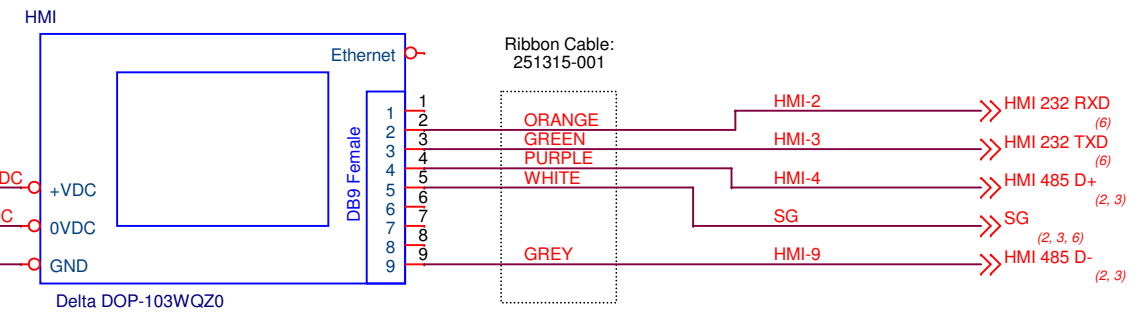
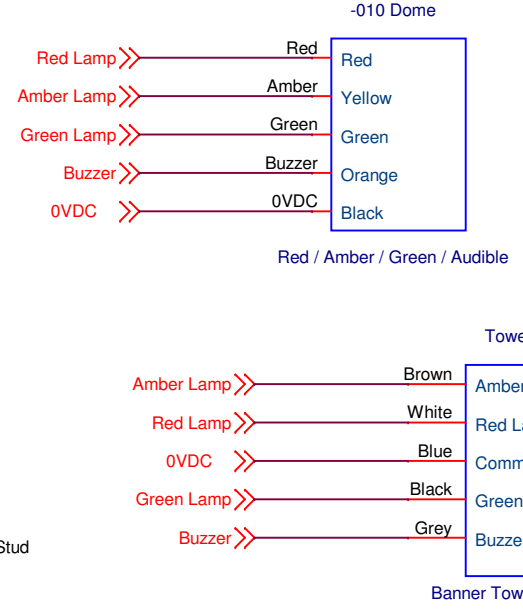

For Plastic Enclosure (Mounted on Labeler Sideplate Post, Single Head Systems)

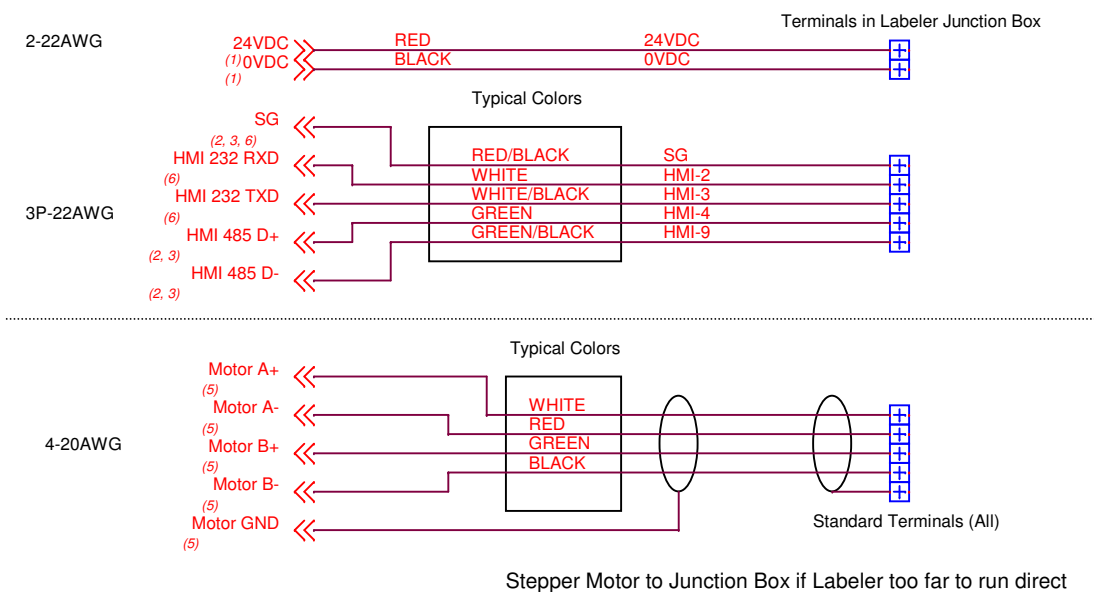

Stack Lamp Option (Cable with Female Connector would be sold & installed with Lamp)

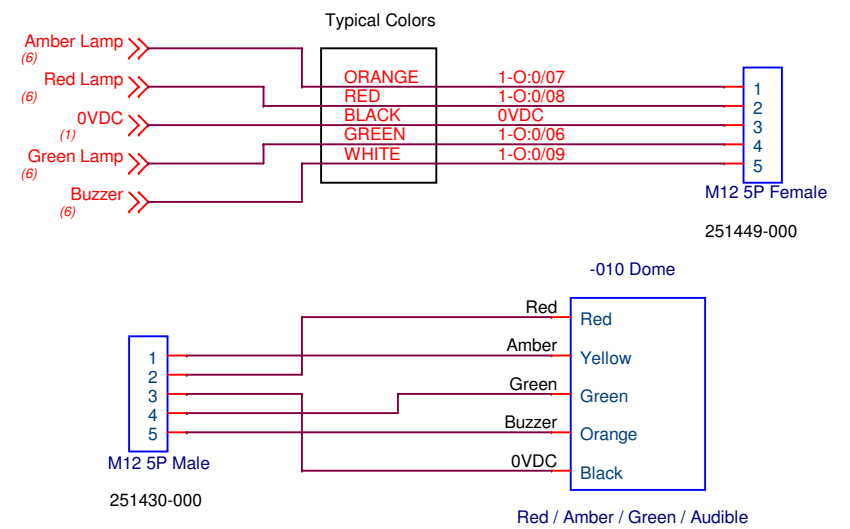

COLOR	TECHNICIAN	DATE

For Quadrel Assembly Use

QUADREL LABELING SYSTEMS
7670 JENTHER DR. MENTOR, OH 44060

D	Printer Relays	CAV	27AUG2025
C	Updated Shielding	CAV	10FEB2025
B	Hugger Options	CAV	30JAN2025
A	Release	CAV	19NOV2024
-	Pre Release	CAV	03SEP2024

Drawn By: CAV
Title: **PACING, HMI**
Schematic #: **SB21820-006** Rev: **D**
Date: Wednesday, August 27, 2025 | Sheet 04 of 07

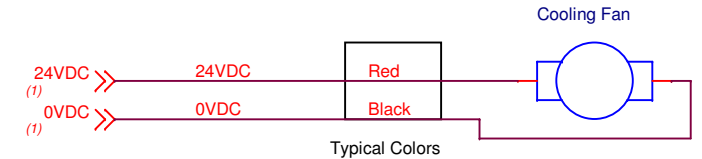
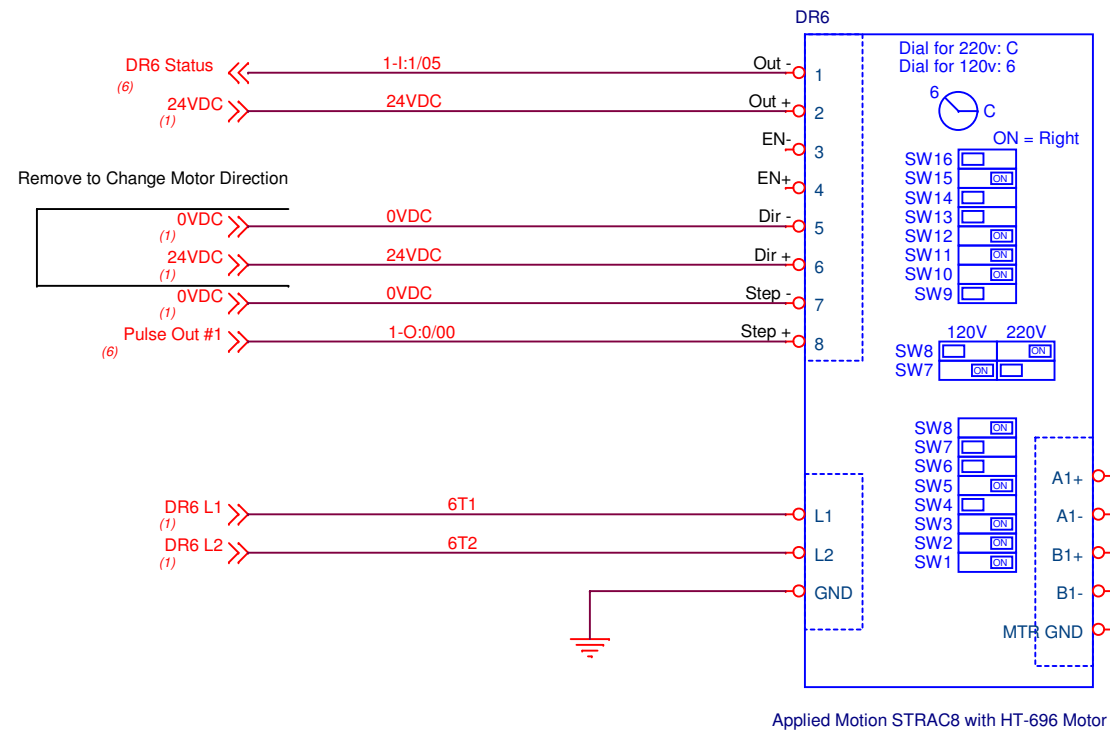

Fan Wiring Through Conduit with Motor Cable

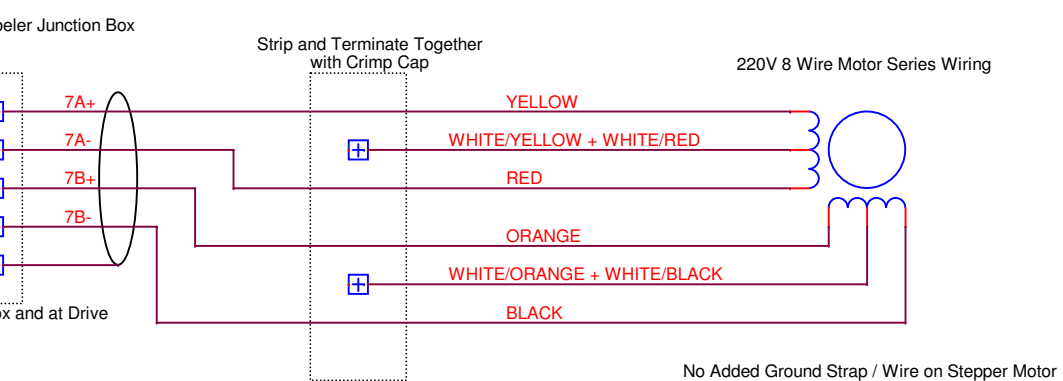
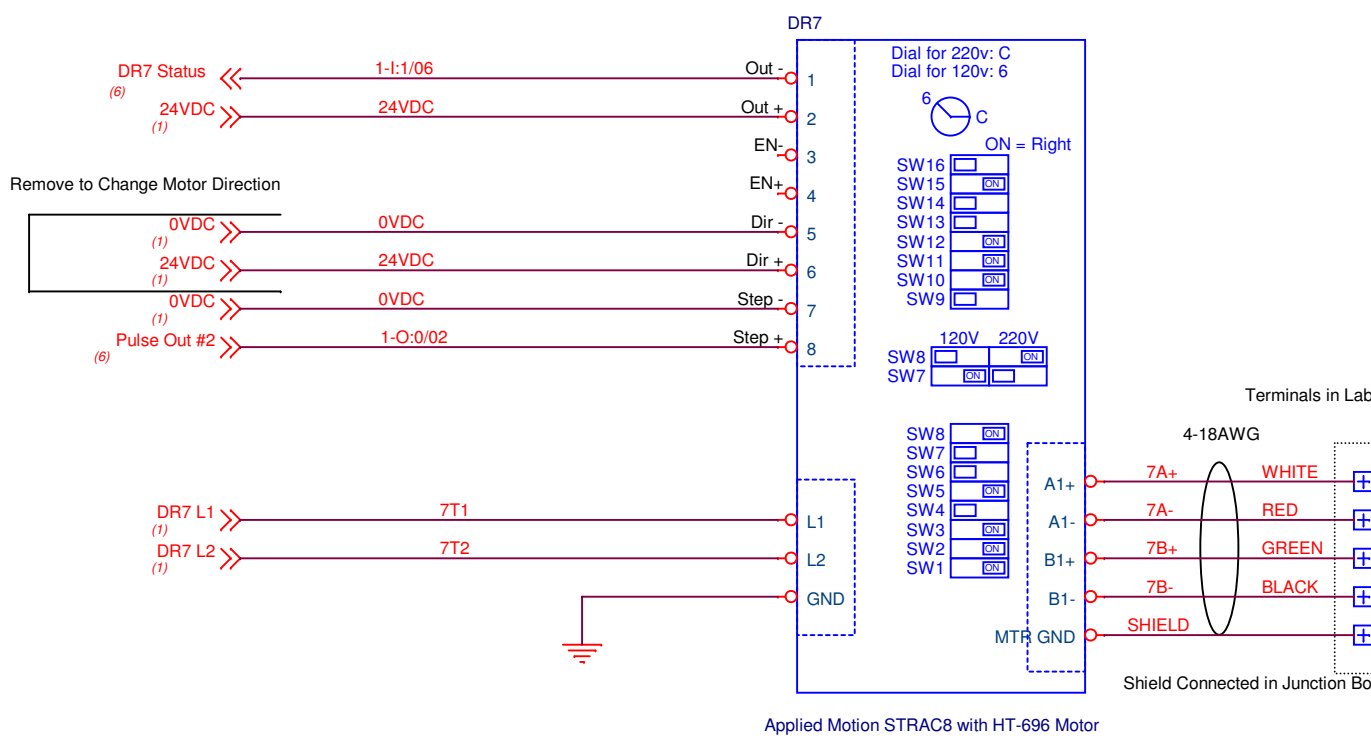
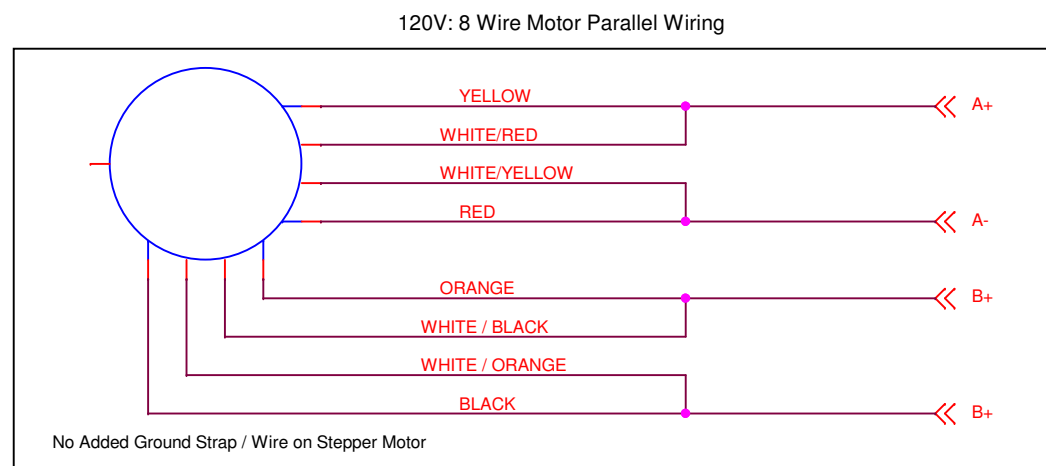
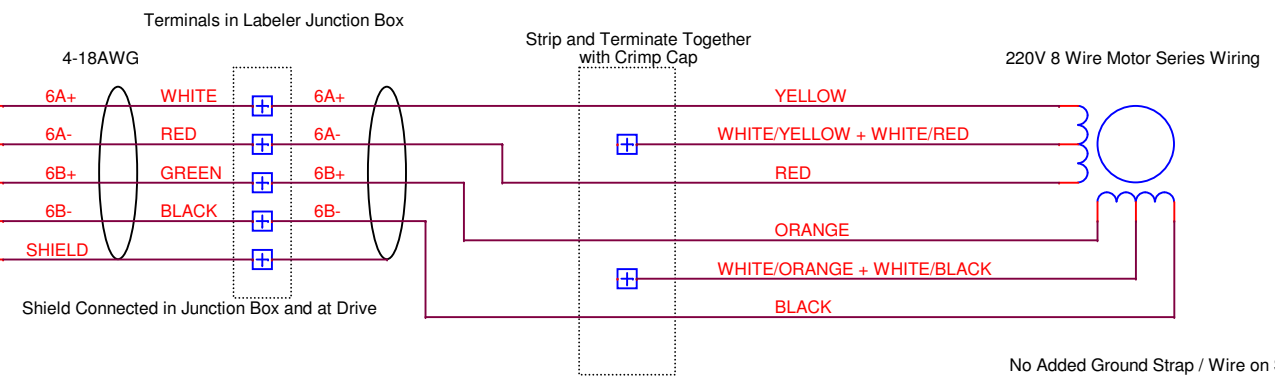

COLOR	TECHNICIAN	DATE

For Quadrel Assembly Use

QUADREL LABELING SYSTEMS
7670 JENTHER DR.
MENTOR, OH 44060

D	Printer Relays	CAV	27AUG2025
C	Updated Shielding	CAV	10FEB2025
B	Hugger Options	CAV	30JAN2025
A	Release	CAV	19NOV2024
-	Pre-Release	CAV	03SEP2024

Drawn By: CAV

REV DESCRIPTION BY DATE

Title
LABELER DRIVES

Schematic # **SB21820-006** Rev **D**

Date: Wednesday, August 27, 2025 | Sheet 05 of 07

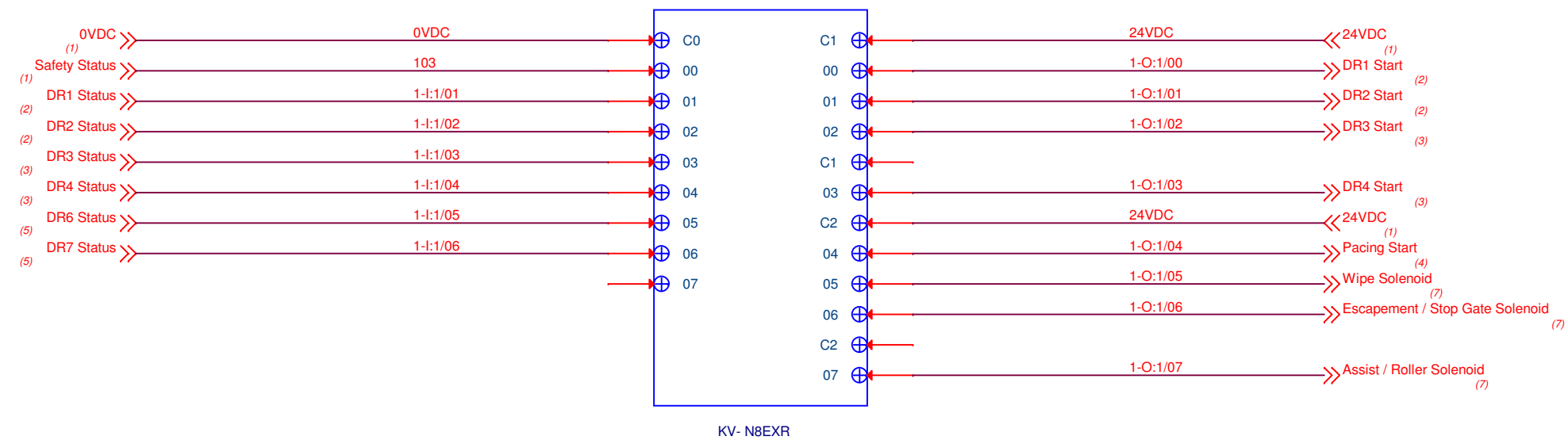
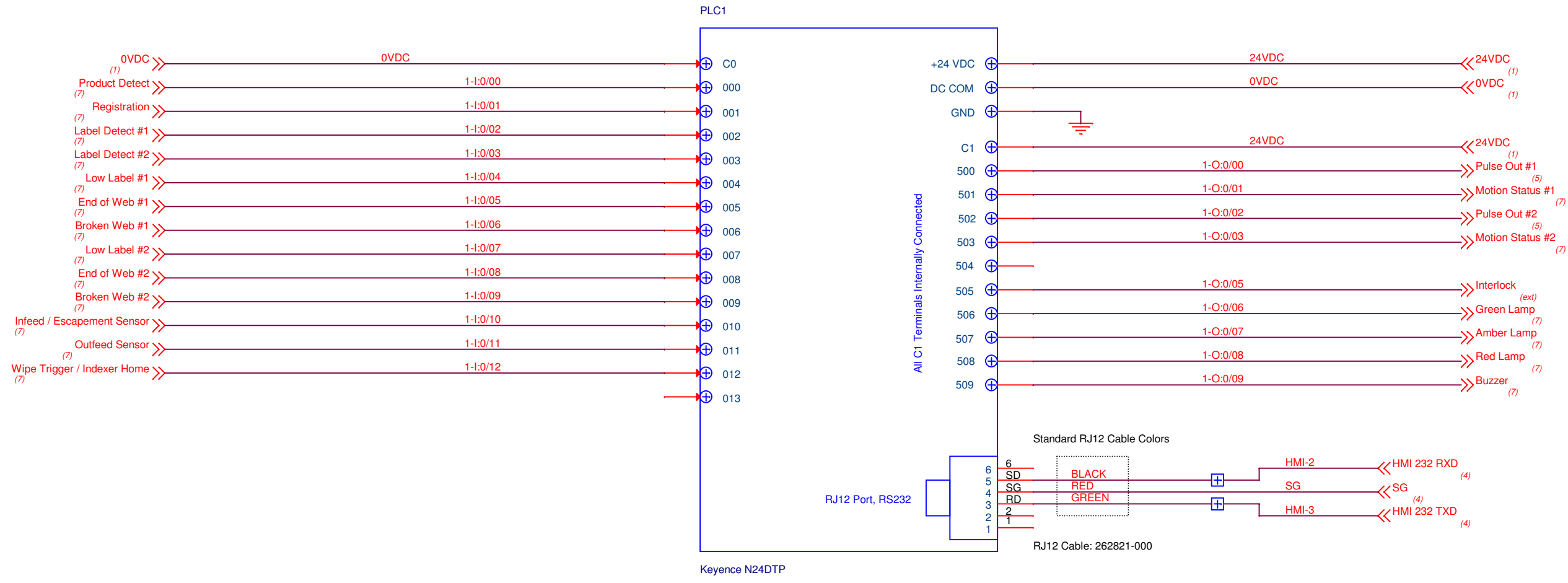

COLOR	TECHNICIAN	DATE

For Quadrel Assembly Use

QUADREL LABELING SYSTEMS
7670 JENTHER DR.
MENTOR, OH 44060

D	Printer Relays	CAV	27AUG2025
C	Updated Shielding	CAV	10FEB2025
B	Hugger Options	CAV	30JAN2025
A	Release	CAV	19NOV2024
-	Pre-Release	CAV	03SEP2024

Drawn By: CAV

REV DESCRIPTION BY DATE

Title
PLC

Schematic # **SB21820-006** Rev **D**

Date: Wednesday, August 27, 2025 | Sheet 06 of 07

Labeler Junction Blocks

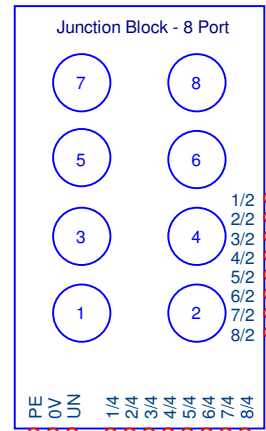

All Signals: PNP

Sensor	Labeler #1	Labeler #2
Low Label	1-I:0/04	1-I:0/07
End of Web	1-I:0/05	1-I:0/08
Broken Web	1-I:0/06	1-I:0/09
Label Detect	1-I:0/02	1-I:0/03
Product Detect	1-I:0/00	N/A
Wipe Trigger	1-I:0/12	N/A
Wipe Solenoid	1-O:1/05	N/A

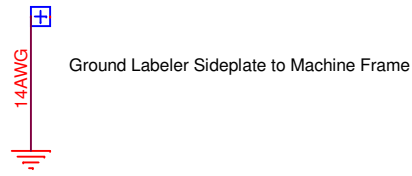

Sensor to Connector Example

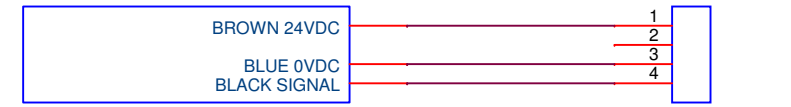

Solenoid Example

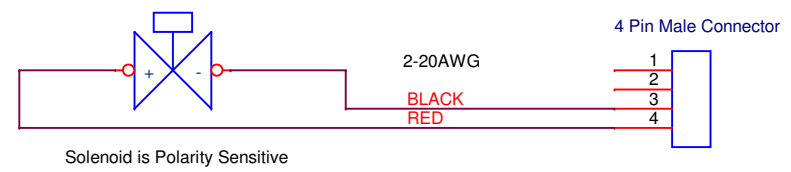

Solenoid is Polarity Sensitive

Typical Colors

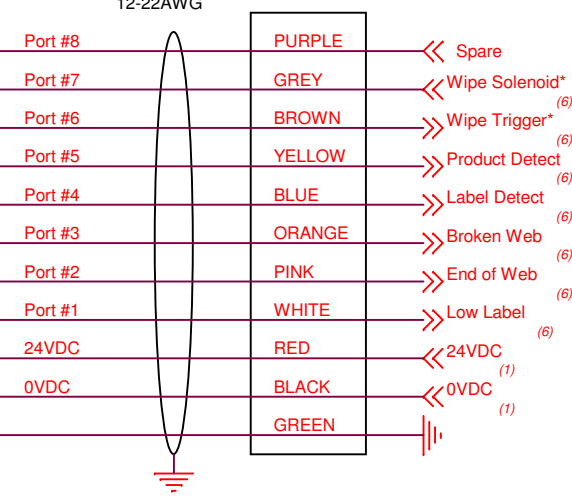

*Used as Spares if 3 Roller Indexer Installed

System Junction Block Option

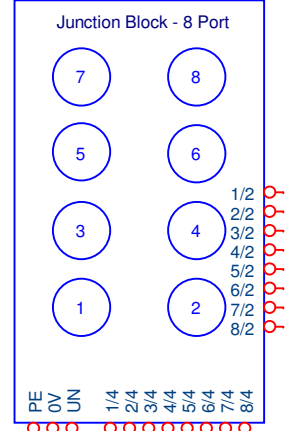

All Signals: PNP

Typical Colors

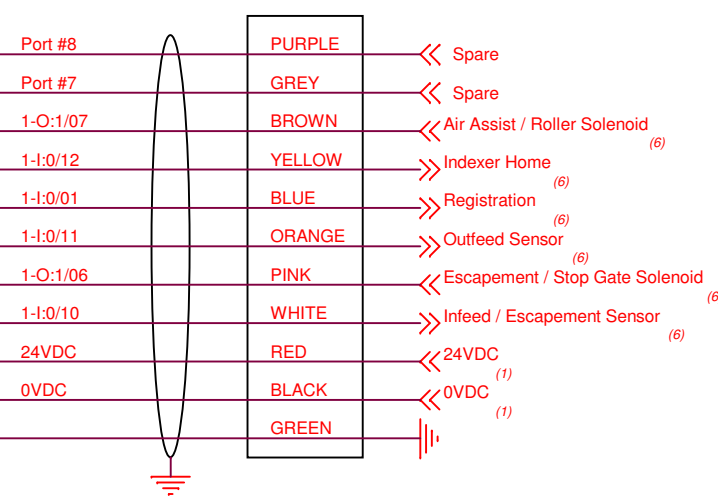

Printer #1 Relay Option

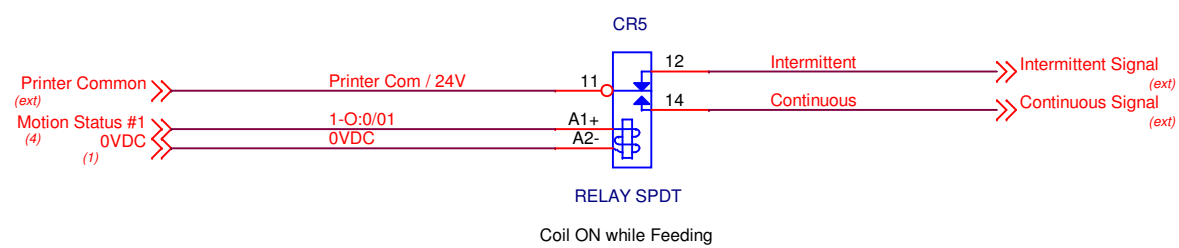

Printer #2 Relay Option

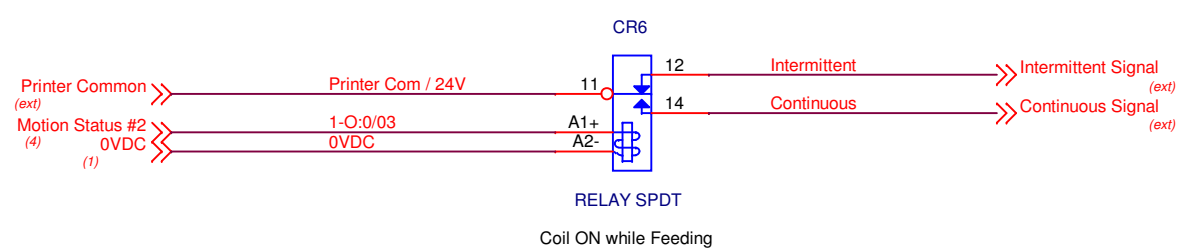

Printer	Com	Signal
Markem X40/X60	BLACK	WHITE
Markem 8018	X4-1	X4-2
Videojet 6330/6530	RED	BLUE
Videojet 6230	RED/WHITE	ORANGE
Allen	23	22

COLOR	TECHNICIAN	DATE

For Quadrel Assembly Use

QUADREL LABELING SYSTEMS
7670 JENTHER DR.
MENTOR, OH 44060

D	Printer Relays	CAV	27AUG2025
C	Updated Shielding	CAV	10FEB2025
B	Hugger Options	CAV	30JAN2025
A	Release	CAV	19NOV2024
-	Pre Release	CAV	03SEP2024

Drawn By: CAV
Title: **SENSORS**
Schematic #: **SB21820-006**
Date: Wednesday, August 27, 2025

9 MAINTENANCE

9.1 GENERAL INFORMATION

This labeler has been designed with the minimal maintenance requirement possible. There are however some things to take into consideration.

The system is built to perform in humid conditions, but must not be pressure washed. In case of wash down conditions, it is recommended to cover each labeling head with a plastic tarp.

For the overall cleaning, it is recommended to use compressed air and clean, damp wipes.

Always turn off the system before proceeding with cleaning and maintenance.

The following section explains the preventive maintenance for each section

After every 100 hours of operation, a visual inspection of the system should be done and where it is necessary, lubricate and cleaning should be performed.



CAUTION

WEAR PROTECTIVE EYEWEAR when performing any maintenance on this equipment.



CAUTION

To reduce risk of fire, electrocution or other personal Injury when operating or maintaining the labeling head, follow basic safety precaution, including the following:

DO NOT perform any servicing or maintenance with the power ON.

Always disconnect the electrical plug from the wall socket

Make sure that the power is OFF or that the available E-stop buttons have been activated.

LABELING SYSTEM

This labeling system is reliable, versatile and durable. It will operate for years with very light maintenance if it is performed regularly. Most of the maintenance takes only a few minutes and substantially increases the operational life of the system and maintains label placement accuracy.

Not all sections may apply to your equipment.

Daily:	D
Weekly:	W
Monthly	M
Quarterly	Q
Semi-Annually	S

ASSEMBLY TITLE: LABELING HEAD ASSEMBLY

D- Remove glue residue and labels from all rollers and idler. DO NOT use a knife or other tool to scrape the rollers. Adhesive Remover such as Goo-Gone or 3M Adhesive Remover is recommended. DO NOT use an adhesive remover that reacts with plastics or sensor lenses will be damaged.

M- Check for loose idlers and components and tighten as needed.

S – Lubricate all idler rollers shafts using 80w-90w gear lube on the white bearings where they contact the axle.

ASSEMBLY TITLE: UNWIND ASSEMBLY

S- Check and adjust dancer spring. If final spring tension is too soft then replace.

S- Check and inspect band brake. Replace if torn

ASSEMBLY TITLE: REWIND ASSEMBLY

S- Check and inspect friction disc (if applicable), Replace when worn out.

S- Check Kinetrol (if applicable) for leaks, Replace if necessary.

ASSEMBLY TITLE: BRAKE BRUSH ASSEMBLY

S- Reverse brake brush direction

S- Inspect Brake brush when brush body contour no longer viable or bristles are worn down. Replace

ASSEMBLY TITLE: SLOT SENSOR ASSEMBLY

D- Keep the sensor optical area clean from label and glue residue

ASSEMBLY TITLE: SIDE PLATE ASSEMBLY

S- Lubricate all idler rollers shafts using 80w-90w gear lube on the white bearings where they contact the axle.

ASSEMBLY TITLE: PEEL PLATE ASSEMBLY

D- Clean all the parts that may acquire labels or glue residue. DO NOT use a knife or other tool to scrape the rollers. Adhesive removers are recommended.

W- Inspect Teflon tape on peel plate tip. Replace if the steel is exposed.

S – Lubricate all idler rollers shafts 80w-90w gear lube

ASSEMBLY TITLE: DRIVE AND PINCH ROLL ASSEMBLY

D- Remove glue residue and labels from drive roller. DO NOT use a knife or other tool to scrape the rollers. Isopropyl alcohol and adhesive removers are recommended.

W- Clean the knurled roll with a soft brass brush and adhesive remover.

M- Check and inspect drive roll. No play should be present when powered up. If there is a groove the width of the label liner, replace the worn roller.

M – Lubricate knurled roll shafts using 80w-90w gear lube.

S- Inspect and Lubricate, springs and slugs.

ASSEMBLY TITLE: ROLLER/BRUSH IMPRESSER

D- Check the rollers/brushes. They should be free of label flash, glue and debris. This will prevent jamming and web tears.

W- Check the foam rollers. If foam wear is noticeable, replace as necessary.

NOTE: Exercise caution when removing bad labels from foam. Careless removal can result in torn foam which may leave the labeler inoperable until the roller is replaced!

ASSEMBLY TITLE: OPERATOR PANEL

-No maintenance is required for the operator panel

-Occasionally, the keypad may be cleaned with any non-solvent based cleaning solution. Glass cleaner on a clean towel then wipe the membrane.

ASSEMBLY TITLE: ELECTRICAL

W- Check the foam filter for the fan. Clean or replace.

ASSEMBLY TITLE: CONVEYOR

D – Inspect conveyor chain for broken flights of table top chain

W – Inspect conveyor for labels / adhesive and remove as needed

S – Check gearbox oil levels and add as needed.

American Lubricants SHC-90W oil.

ASSEMBLY TITLE: FEEDSCREW

W – Remove glue residue and labels from feed screws

W – Lubricate internal feedscrew drive assembly, with multi-purpose grease.

S – Lubricate grease fittings / chains / bearings with quality multi-purpose grease – as needed

ASSEMBLY TITLE: VERTICAL ROLLER

W – Remove labels from rollers with adhesive remover / cleaner

W – Lubricate chains with food grade grease.

ASSEMBLY TITLE: EJECT STATION

D – Clean all parts that have acquired label or glue residue

ASSEMBLY TITLE: INFEEED / OUTFEED BANK SENSOR

W – Clean and glue residue or labels off sensor and/or reflectors

ASSEMBLY TITLE: SLEEVE

M – Drive rollers – Inspect for wear and clean with a citrus based adhesive removal

M – Inspect tension belts for cutter blade and cutter assembly for wear. Replace as needed.

M – Inspect cutter blades and bearings for wear. Replace as needed

M – Inspect perforation blades / bearings for wear and free of debris. Replace as needed.

S- Check, inspect, and grease all lead screws (threaded rods)

S – Inspect mandrel and bearings for wear. Ensure they spin freely
Replace as needed.

NOTES:

GENERAL PURPOSE FEEDSCREW LUBRICATION GUIDE

During your weekly maintenance of your Quadrel Labeling Systems equipment follow the steps below to ensure proper lubrication of the internal drive system for your feedscrew assembly.



Step 1 – Your dual feedscrews are connected inside the conveyor with a spline shaft assembly. First remove the chain so you have easy access to the this.



Step 2 – Open your feedscrews to your largest product. This will expose the spline assembly shaft that you will be applying the multi-purpose grease to.

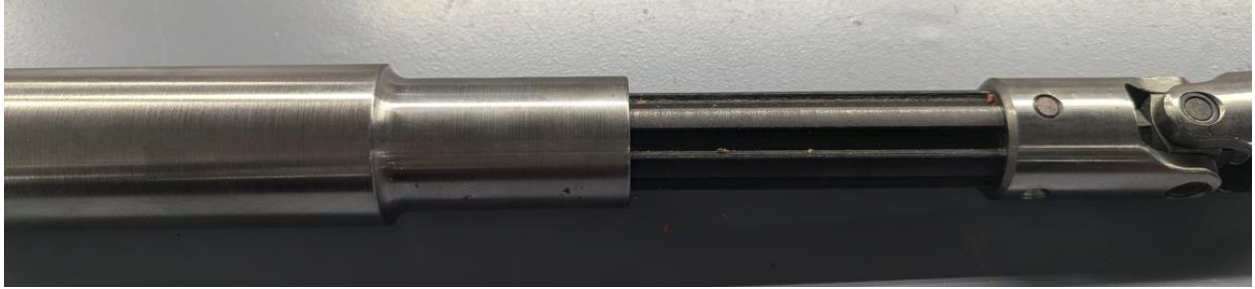

Step 3 – Apply multi-purpose grease to the now exposed spline shaft assembly. Ensure to apply multi-purpose grease all the way around the spline shaft– Top, bottom and sides

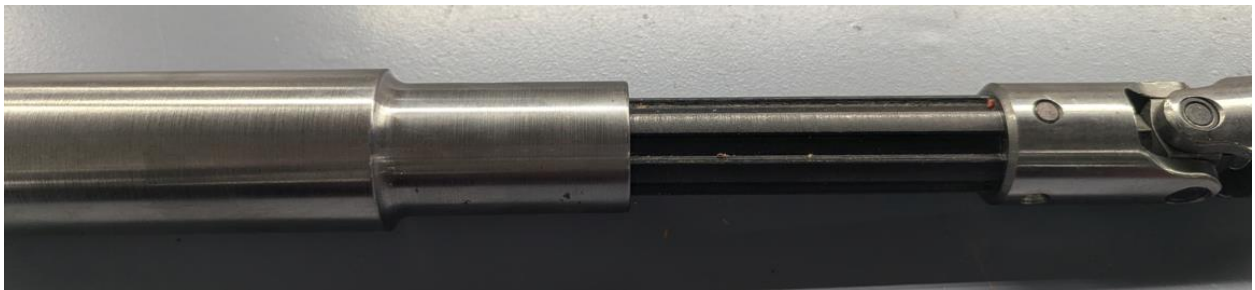

Step 4 – Slowly move the feedscrews in and out to so the grease can spread evenly over the length of entire spline shaft assembly.

Step 5 – Reconnect conveyor chain

Setup procedure for Powered rewind using MGC403-11-00MD drive

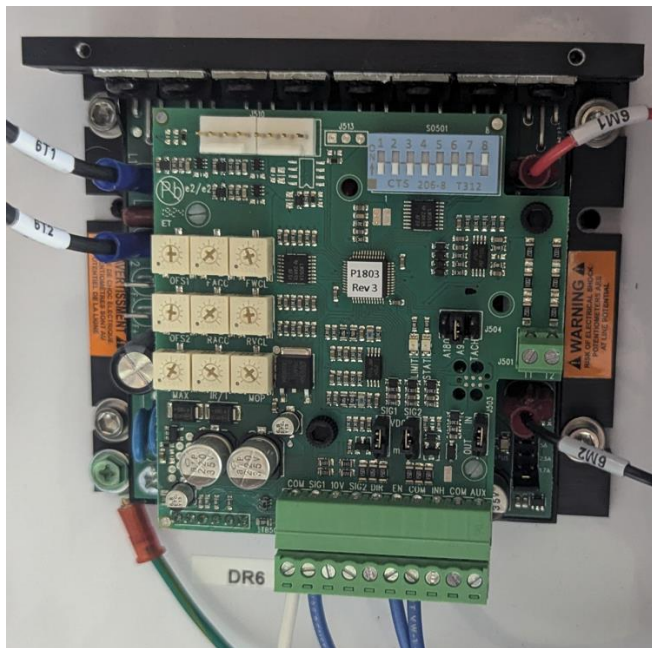

Upon receiving drive set the following **BEFORE** installing in the machine.

1. Dip switches - set all switches to the off position. This is the Light blue row of switches shown in the image below

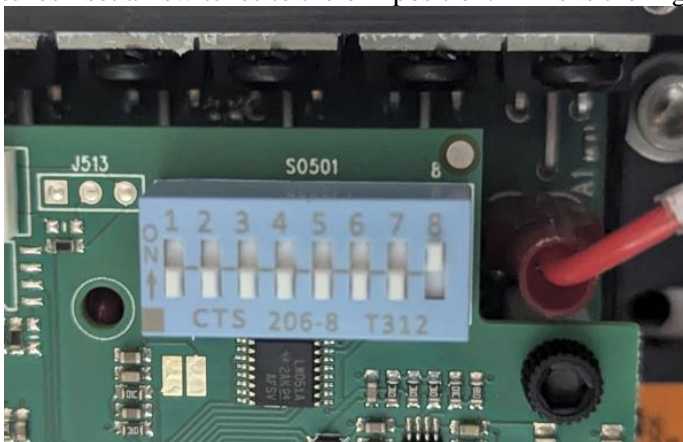

- a.
2. Set Jumpers on drive based on electrical schematic for your machine
 - a. SIG1 – VDC
 - b. SIG2 – VDC
 - c. J504 – A90
 - d. AMP CURRENT – 1.7A – This located near the 10 pin green connector that

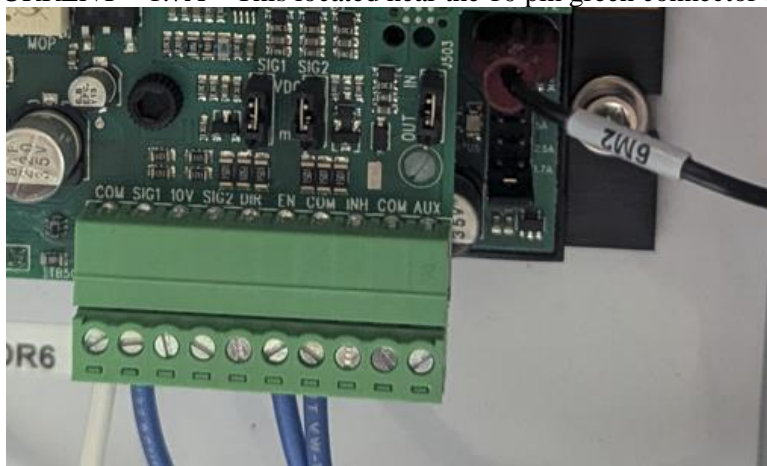

i.

3. Using a small flat blade / Slot screwdriver adjust the following pots as indicated in the image below:

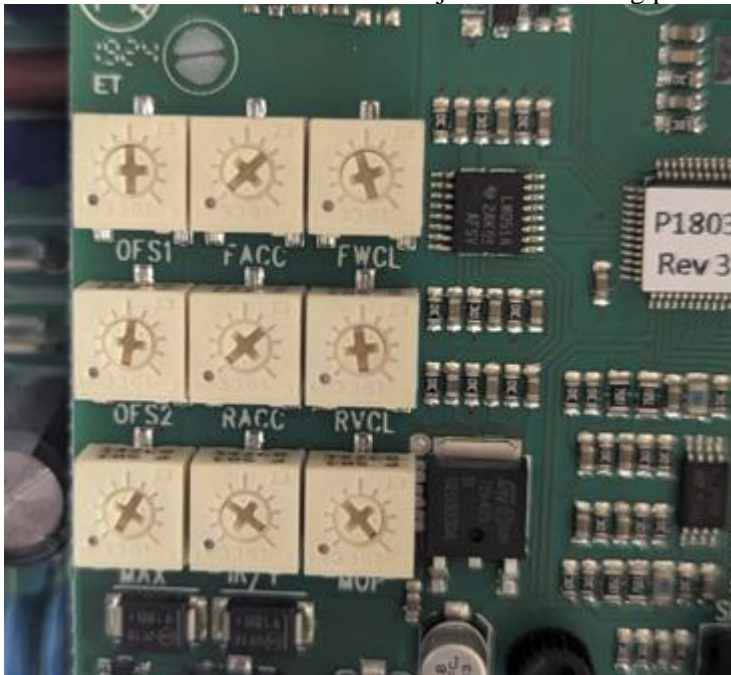

- a.
- i. Top row **OFS1** – WILL BE ADJUSTED AT LATER STEP
 - ii. Top row – **FACC** - turn counter clockwise until it stops.
 - iii. Top row **FWCL** – set to half way point – midpoint
 - iv. Middle row - **OFS2** – turn counter clockwise until it stops. This turns the pot OFF
 - v. Middle row – **RACC** - turn counter clockwise until it stops
 - vi. Middle row – **RVCL** – set to half way point – midpoint
 - vii. Bottom row – **MAX** – Set to 3/4 point
 - viii. Bottom row – **Leave other 2 pots at factory setting – DO NOT ADJUST**

4. Install drive in machine then proceed to next steps

5. Set the Cam on the rewind dancer per image below when the dancer arm is at rest. Rest is when the arm is all the way back against the rubber bumper as shown

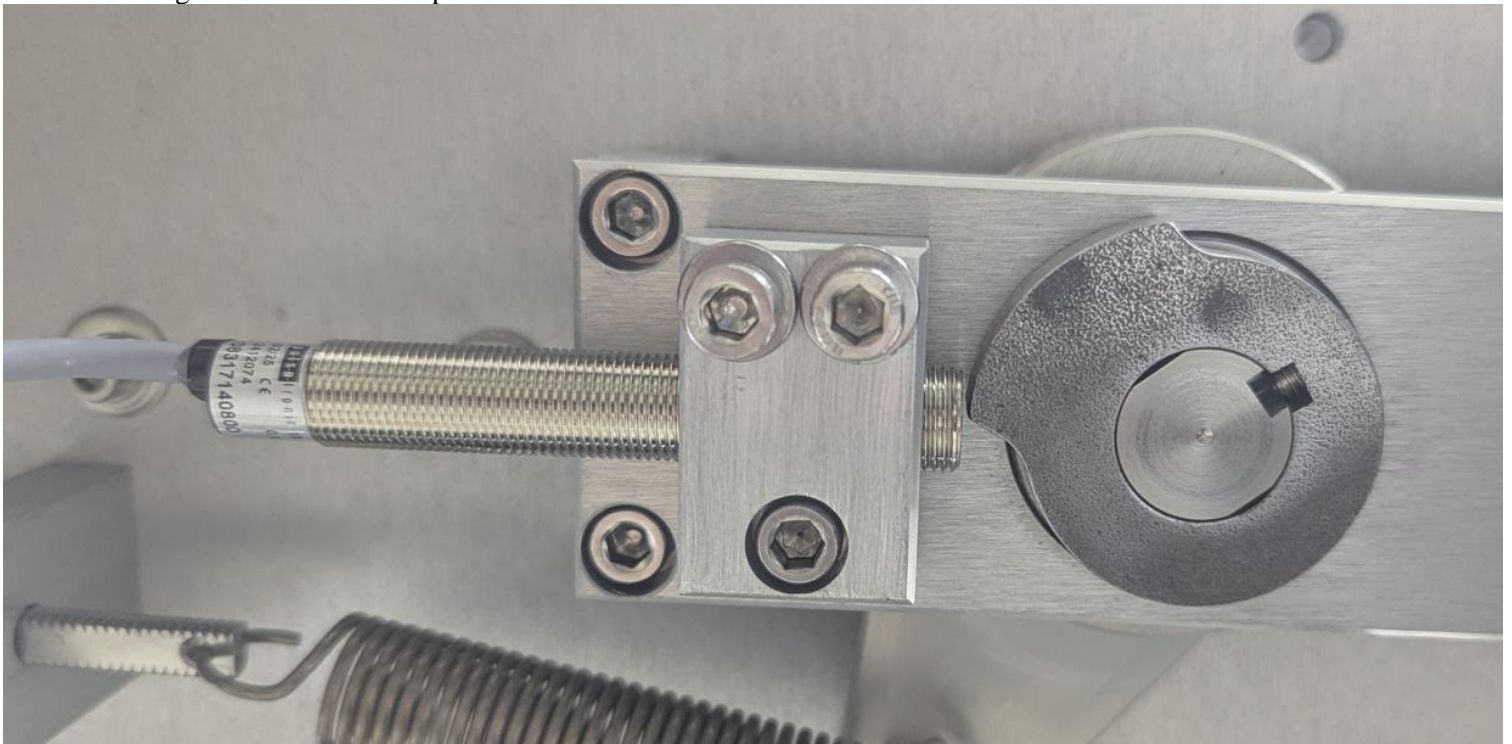



6. On the HMI go to into labeling head service menu. You will be looking at the REWIND PROX VOLTAGE (example below)

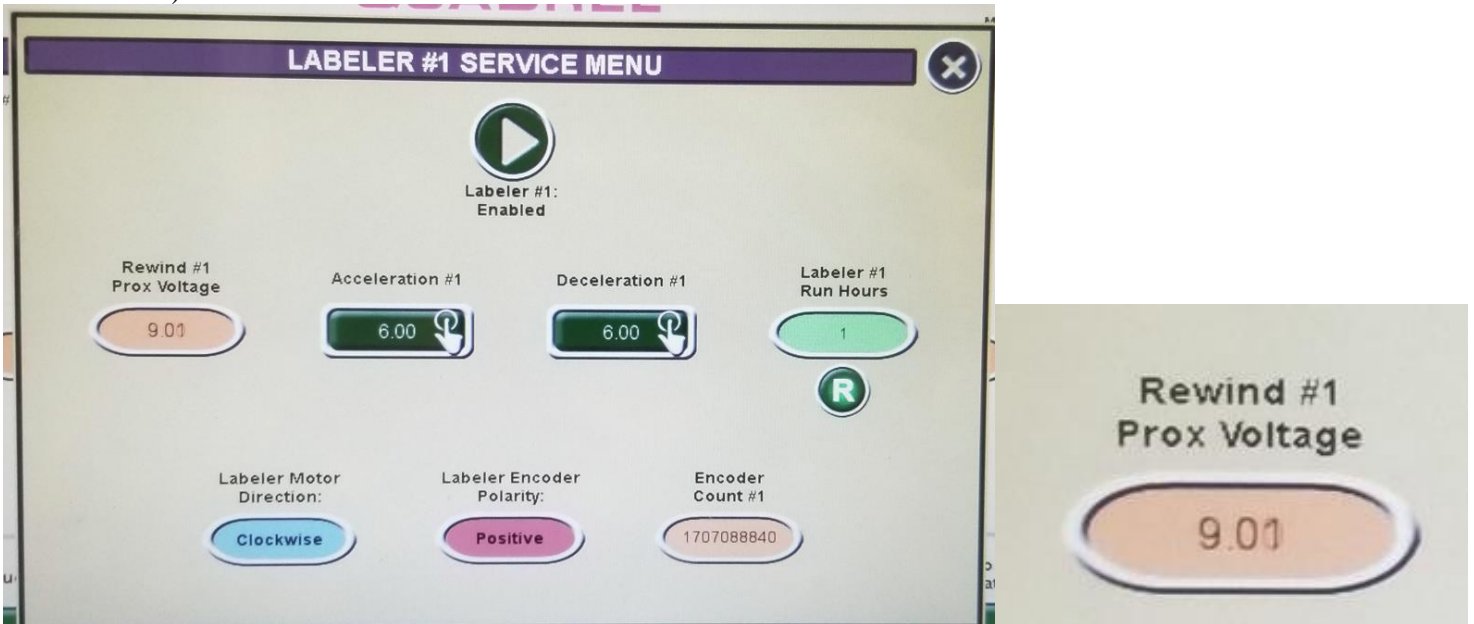

7. Adjust the sensor gap at the cam by loosening the bolt using an allen key so that the sensor can be moved forward or backward. The bolt does NOT touch the sensor. Loosening it opens the clamp so you can adjust.
8. Set the gap so the REWIND PROX VOLTAGE on the HMI reads **.90 it must be under 1 volt.**
 - a. **Retighten screw so the clamp sensor no longer moves**

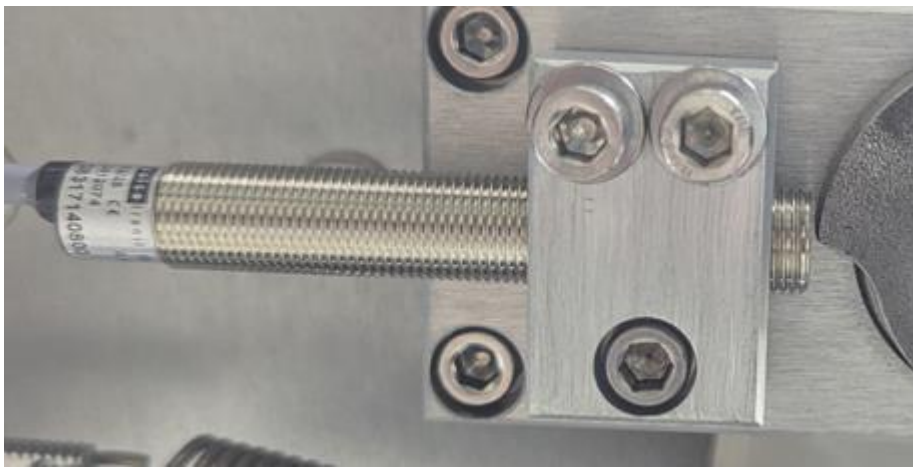

b.

9. Test by moving the rewind dancer arm forward. When doing this you should see the rewind prox voltage on the HMI increase up to 9 volts

a. If you do not see the voltage increase steadily, recheck cam sensor gap in step 7

10. Turn on rewind switch on the back of the labeler. This will engage / turn on the motor.

11. Move the rewind dancer arm forward the rewind hub should start to turn clockwise. It will slow then stop as you move forward. Rewind hub should ALWAYS be turning clockwise. If it moves counter clockwise move to **step 11a**

a. While holding the arm in the position where it started to run counter clockwise, it MUST be running counter clockwise, you will adjust **OFS1** until the rewind hub stops moving.



i.

b. This adjustment may need to be done multiple times until it no longer moves counter clockwise when rewind arm is all the forward and at rest.

9.2 BELTS

Monthly, a visual inspection of the rewind belt and timing belt, to do this depending on the labeling head you may need to remove the bottom cover on the head.

Refer to photos below.

Servo labeling head.

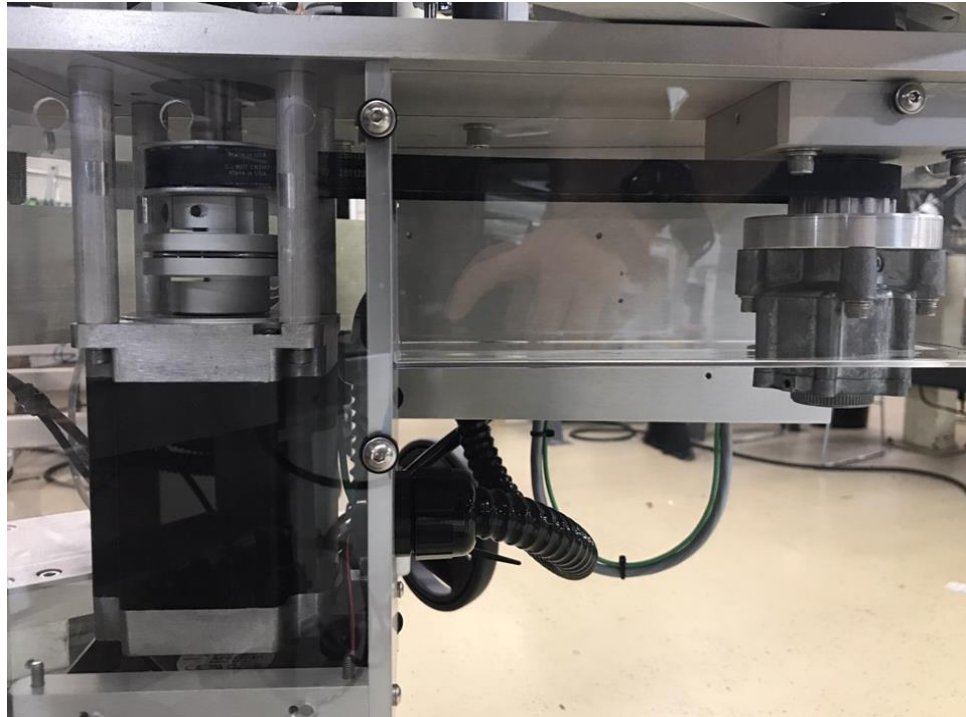

Stepping labeling head.

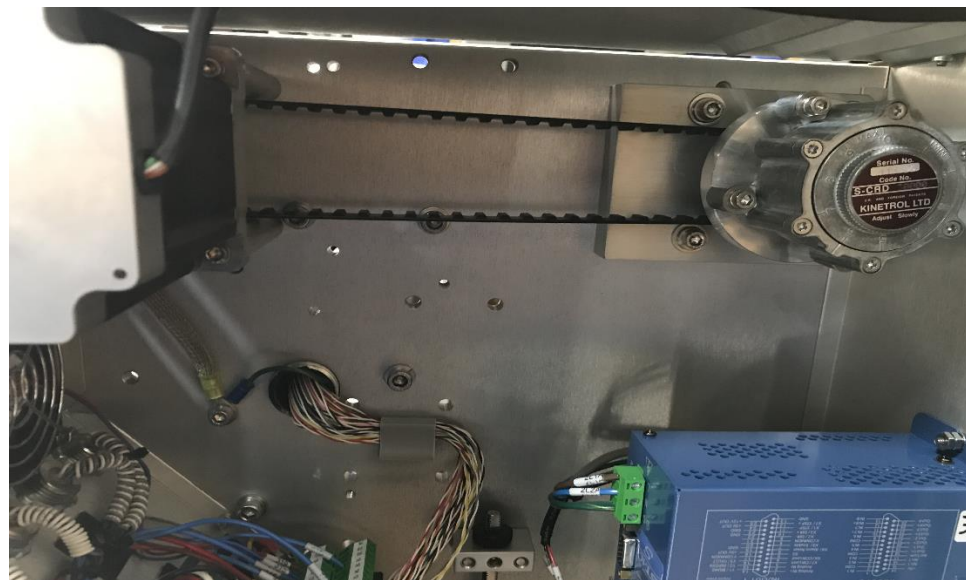

CAUTION

DO NOT ATTEMPT doing this with the equipment under tension (with power on).

The visual inspection should consist of looking for cracks or defects in the belts. If this is the case, change the belts that are defective. Refer to the parts listing in the labeling head section of this manual.

The brake band mechanism requires a monthly visual inspection as well. Also once every 12 months you should consider replacing the belt (it is possible that you may need to change it later or earlier than 12 months depending the usage of the labeling head).

The brake band belt assembly is located at the base of the unwind assembly. See images below for reference.

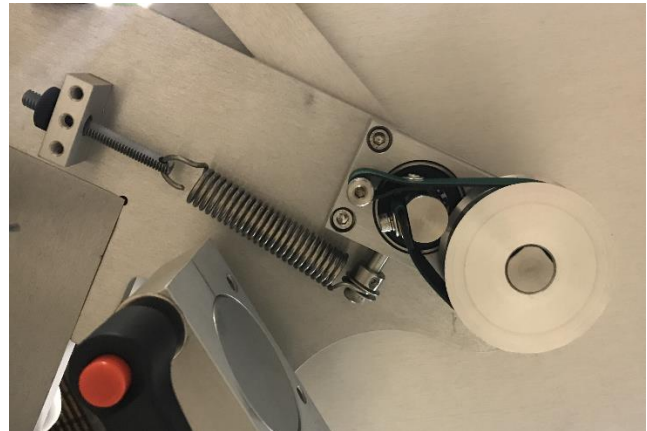
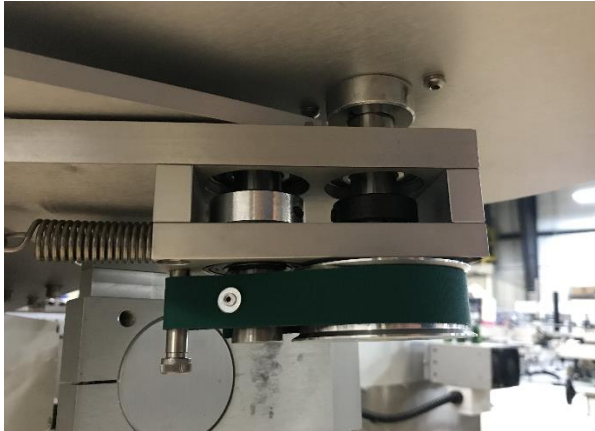

For replacement parts see the unwind assembly drawing for your labeling head in this manual.

9.3 ROLLERS

It is important that your labeler is as clean as possible in its environment in order for it to perform properly. Daily, it is suggested to clean all the rollers including the drive roller (the rubber roller), the pressure shoe and peel plate using a damp cloth with alcohol. Make sure those parts have no glue or labels on it.

Weekly, spray a silicone base lubricant on each end of the plastic bearing.

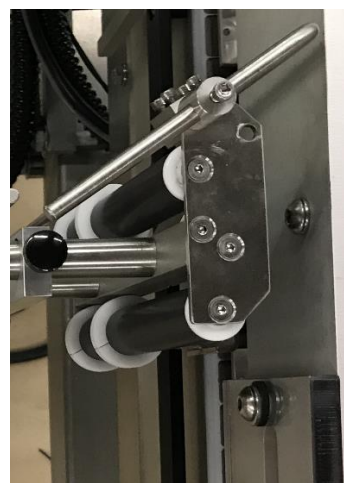
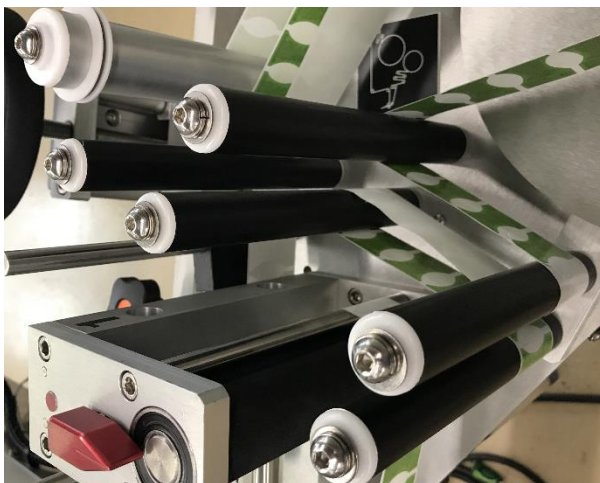

9.4 SENSORS

The sensors all have an electronic eye called a photocell; these must be free of lint or dirt. Since the photocells are generally made with glass or plastic lenses. They naturally attract substances which could easily trigger the sensor, use a cotton swap to gently clean the eye of the sensor as you would any lens, in a circular motion.

9.5 CONVEYOR

Always keep the belt or (chain) clean. To clean it simply use compressed air with an osha approved nozzle and/or damp wipes. If necessary, a soft cleaning agent can be used.

9.5.1 CLEANING

To clean the under carriage portion of the conveyor, simply remove the belt using an punch or similar tool and hammer to tap out the retaining belt link pin. (see images below, the chain has an orientation to the pins, you must tap it out from the narrow diameter) Clean the desired portion with a damp cloth and replace the pin to the belt. The pin will be tapped in the opposite side you tapped it out. *You can also lift the chain and wipe under it.

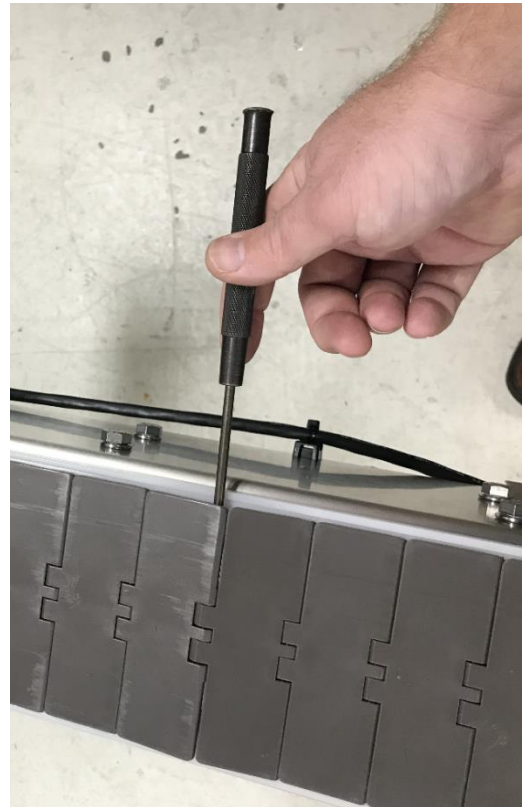
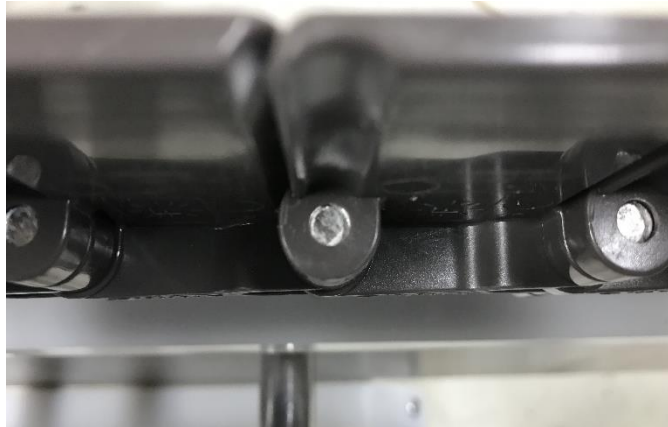

10 CLEARING A JAM

In the event a jam occurs on your Quadrel Labeler reference the following steps to clear.

1. Press the conveyor stop button or the emergency stop if you are unable to reach the stop button.
2. Clear the jam manually in the affected area of the equipment where jam is located
3. Once jam is cleared reenergize the estop, if pressed, and press the reset button (where applicable) to clear faults.
4. Put equipment back into "run" and press start to turn the system back online to continue labeling

11 WARRANTY

The standard warranty period for Quadrel equipment is 12 months following invoicing. The warranty covers all parts with consideration taken towards reasonable use and normal wear and tear. Not covered by warranty are parts that have a limited wear factor, any required labor by Quadrel. Prior to return to Quadrel, parts must be verified defective.

Return of defective parts

To return a defective part, you will need to get an RMA number from Quadrel. All RMA's are issued through our parts department. Please specify the serial number of the equipment, the client's name, address, phone number, contact name and the nature of the problem. To get a replacement part, a purchase order is required. You will be billed for the new part and credited for the defective part after return and evaluation. If the part is determined to be defective due to improper use, no credit will be issued.

Appropriate Use of Equipment

The equipment supplied to the end user by Quadrel are to be used for the sole purpose for which they were intended and must follow Quadrel's specifications on usage as well as appropriate functions. Quadrel will not assume any responsibility for any inappropriate use or modifications to the said equipment other than for the use it was initially built for. The warranty will cease to apply forthwith, in Quadrel's opinion, the equipment has been used abnormally or in an abusive manner, if it has not been properly maintained, if it has not been carried on a truck equipped with an air-ride suspension when required by Quadrel or if it has been used, or maintained contrary to the owners manual provided by Quadrel.

Responsibility Limits

The solution put forth has been prepared with the information that has been provided to Quadrel by the end user. Subsequently, Quadrel cannot assume any responsibility for the exactitude, precision, and the validity of the information which was supplied. Moreover, Quadrel cannot be responsible for (a) any damages, direct or indirect, secondary, or

accessory, including without limitations, the loss of profit, workflow interruption, loss of production, loss of profits and other; (b) any and all damages claimed against the end user by a third party; (c) any or all damages caused to the property of end user or any other third party; (d) any or all resulting in an act from the end user or third party, major force, or act of god, unforeseen cause, or event.

With all reservation, in the eventuality where the responsibility is that of Quadrel relative to any defect of quality of said equipment or proposed solution Quadrel would be able to accept the responsibility, to its entire discretion, with the replacement of part of the said equipment or solution. By a compatible or identical equipment or solution or by a reimbursement of value agreed upon. In no case can Quadrel's responsibility exceed the total monetary sums received for the said defective equipment or solution.