

QUADREL

LABELING SYSTEMS

Operating & Maintenance
Manual
For

ENVIRO-TEX PRODUCTS, INC

Q60 SERVO W/ DUAL SIDE BELTS

Automatic Labeling System

Labeler Model #: Q60 SERVO
Serial #: 84263-100 & 84263-200

QUADREL LABELING SYSTEMS
7670 Jenther Drive
Mentor, Ohio 44060
440.602.4700

customerservice@quadrel.com
parts@quadrel.com

TERMS AND CONDITIONS OF SALE

QUADREL, INC

D/B/A Quadrel Labeling Systems Hereinafter Referred to as Quadrel

PERFORMANCE GUARANTEE:

If the surface of the product to be labeled is free from contamination so as to ensure proper label adhesion, the labels are manufactured in accordance with label specifications provided and the equipment is operated and maintained in accordance with the instructions contained in the Quadrel manual (two copies of the manual will be supplied by Quadrel with the labeling system; one printed copy, and one electronic copy). Quadrel guarantees the EQUIPMENT to perform after installation as stated.

1. Provided a sufficient amount of products are presented to the labeling system.
2. Dimensional inconsistency from one like product to be labeled to the other may result in additional label placement inaccuracy in direct relationship to the product inconsistency.
3. Slitting inconsistency within a given roll of labels or from one like roll to another may result in additional label placement inaccuracy in direct relationship to the slitting inconsistency.
4. If the Quadrel labeling system proposed herein does not include physical control of the product during label application, additional placement inaccuracy can occur in direct relationship to the product control inconsistency.
5. Label Placement Accuracy: Within Sigma 2 (approximately 95.5%) to be normal.

In the event of the failure if the Quadrel system to meet customer's specifications, as quoted by Quadrel or subsequently agreed to by Quadrel. Quadrel upon written notice from buyer shall, at its option, repair the system, or refund the purchase price upon return of the system. The warranty provided in this article and the obligations and liabilities of Quadrel thereunder are exclusive and in lieu of, and buyer hereby waived, other remedies warranties, guarantees or liabilities, express or implied arising by law or otherwise (including without limitation, any obligations of Quadrel with respect to fitness for a particular purpose, merchantability, specific performance, incidental and consequential damages) whether or not occasioned by Quadrel's negligence. This warranty should not be extended altered or varied except by written instrument signed by Quadrel and buyer.

EXCLUSIVE TERMS OF SALE: The proposal attached hereto or to which these Terms and Conditions of Sale apply (the "Proposal"), together with these Terms and Conditions of sale (collectively, the "Sale Agreement"), constitutes the complete and exclusive statement of the agreement between Quadrel and the purchaser specified in the Proposal ("Purchaser") concerning the equipment and other goods specified in the Proposal (collectively, the "Equipment"), as well as any and all services specified in the Proposal (collectively, the "Services"), and supersedes all prior contemporaneous agreements, representations and/or communications, either oral or written, between Quadrel and Purchaser or any representative such as parties with the respect to the subject matter of the Sale Agreement. No change to the Sale Agreement or waiver of any provision thereof will be binding on Quadrel unless made in writing and signed off by and authorized officer of Quadrel. Acceptance of the Equipment, in whole or part, or other express or implied assent by Purchaser to the terms hereof shall constitute Purchaser's agreement to the terms of the Sale Agreement. Acceptance of any purchase order or other document of Purchaser by Quadrel is expressly made conditional on the Purchaser's assent to the Sale Agreement. ANY ATTEMPTED MEMORIALIZATION OF THIS SALE BY A PURCHASE ORDER OR OTHER DOCUMENT CONTAINING TERM AND CONDITIONS INCONSISTANT WITH OR IN ADDITION TO THE CONDITIONS CONTAINED IN THE SALE AGREEMENT SHALL NOT BE BINDING UPON QUADREL AND QUADREL HEREBY EXPRESSLY OBJECTS TO AND REJECTS THE SAME.

GENERAL WARRANTY (EXCLUDES TABLETOP LABELERS)

Time from date of shipment	Covered Expenses
Up to 90 Days	All Parts , service time, living and travel expenses
UP to 12 Months	All parts

THE WARRANTIES PROVIDED ABOVE ARE IN LIEU OF ANY AND ALL OTHER WARRANTIES AND LIABILITIES, EXPRESSED OR IMPLIED, INCLUDING BUT NOT LIMITED TO ANY WARRANTIES OF MERCHANTABILITY OR FITNESS FOR ANY PARTICULAR PURPOSE. NO OTHER WARRANTIES ARE OFFERED BY QUADREL WITH RESPECT TO THE EQUIPMENT OR SERVICES AND QUADREL HAS NOT AUTHORIZED ANY EMPLOYEE OR AGENT TO OFFER ANY WARRANTIES EXCEPT THOSE PROVIDED ABOVE. PURCHASER AND QUADREL EXPRESSLY AGREE THAT THE WARRANTIES PROVIDED ABOVE SHALL SERVE AS PURCHASER'S SOLE AND EXCLUSIVE REMEDY WITH RESPECT TO THE EQUIPMENT AND SERVICES.

PURCHASER REQUIREMENTS. Purchaser must provide Quadrel descriptions and specifications of all labels and items to be labeled, including, without limitation, label material, product and label dimensions, and any other items required by Quadrel. Further, purchaser shall furnish Quadrel one (1) production size roll of each label and 100 samples of each item to be labeled for testing purposes. **Quadrel shall have no liability (whether under its Limited One-Year Warranty or otherwise) for labeling performance on labels or items to be labeled:**

- (a) Which were not specified or sufficiently described in the Proposal: or**
- (b) With respect to which Purchaser fails to provide Quadrel the samples specified herein, even if such labels or items to be labeled were specified in the Proposal. Further, Quadrel shall have no liability for delays caused by Purchaser's failure to furnish samples as specified herein.**

LIMITATION OF WARRANTIES. Quadrel shall have no obligation to honor its warranties and shall have no liability with respect to defective Equipment if:

- (a) The Equipment has been modified, altered, damaged, abused or used for any other than those purposes intended by Quadrel.
- (b) The Equipment has been changed without prior written consent from Quadrel.
- (c) The equipment has not been operated and maintained in accordance with generally accepted commercial practices for similar equipment and Quadrel's specifications and instructions, as published in the Quadrel manual.
- (d) The surface if the product to be labeled is not clean and free of contamination, including, but not limited to, mold release agents, condensation, dirt and oil.
- (e) Labels are not manufactured in accordance with label specifications provided by Quadrel, or are not from defects such as cracked edges, deep die strikes, *etc.*
- (f) Labels and items to be labeled are not set forth in the Proposal.
- (g) Samples of all products and labels were not provided to Quadrel for testing prior to Equipment shipment as required under "Purchaser Requirements" outlined above.
- (h) There is dimensional inconsistency from one like roll of labels to another.
- (i) *The Equipment does NOT include physical control of the product.*

LIMITATION OF REMEDIES. All warranty claims shall be subject to review and approval by Quadrel. Quadrel's obligation to honor warranties is in all cases limited to, at Quadrel's sole option:

- (a) Repair of defective Equipment or components: or
- (b) Providing a cash refund or credit, after Purchaser has returned Equipment to Quadrel.

Where warranty service is to be provided at the Quadrel facility, Purchaser shall return Equipment claimed to be defective to Quadrel, freight prepaid, for review. No Equipment shall be returned to Quadrel, whether for inspection, repair, refund, or any other reason, without prior return authorization from Quadrel. Quadrel may charge Purchaser cost resulting from testing, handling and disposition of Equipment claimed to be defective by Purchaser which is found by Quadrel to conform to Quadrel's warranties.

LIMITATION OF LIABILITY. QUADREL SHALL HAVE NO LIABILITY FOR ANY CONSEQUENTIAL, INCIDENTAL, PUNITIVE OR SPECIAL DAMAGES BY REASON OF ANY ACT OR OMISSION OR ARISING OUT OF OR IN CONNECTION WITH THE (a) EQUIPMENT OR ITS SALE, DELIVERY, INSTALLATION, MAINTENANCE, OPERATION, OR PERFORMANCE, OR (b) SERVICES. IN NO EVENT SHALL QUADREL'S LIABILITY EXCEED THE PRICE OF THE EQUIPMENT (OR THE PRICE OF THE SERVICES IF A CLAIM IS MADE WITH RESPECT TO THE SERVICES) WITH RESPECT TO WHICH A CLAIM IS MADE REGARDLESS OF WHETHER SUCH CLAIM IS BROUGHT

AT LAS OR IN EQUITY AND REGARDLESS OF WHETHER SUCH CLAIM IS BROUGHT UNDER CONTRACT, BREACH OF WARRANTY, TORT OR ANY OTHER THEORY OF LAW OR EQUITY.

ORDERS:

Orders entered, verbal or written, cannot be cancelled except upon terms that will compensate Quadrel against any and all claims

START-UP SERVICE:

Quadrel will provide, at standard installation rates, the number of normal eight-hour working days for the Quadrel Field Service Technician to start the EQUIPMENT and to train PURCHASER'S operating and maintenance personnel. EQUIPMENT is not uncrated and emplaced in desired location by PURCHSER prior to arrival of Quadrel Field Service Technician, or if the EQUIPMENT cannot be made operational due to non-availability of products, labels, appropriate utilities and/or related production equipment, PURCHASER shall pay Quadrel for additional service time required including travel expenses, if applicable, in accordance with Quadrel's Field Service rates. It is PURCHASER's obligation to schedule the start-up service at a time when PURCHSER'S engineering, maintenance and selected production personnel are available.

SERVICE AFTER INSTALLATION:

Quadrel Field Service Technicians are available to customers who do not maintain their own service departments. This can be handles on a per visit basis. Field Service rates are available on request.

PAYMENT TERMS:

Payment terms are as follows: 50% of purchase with purchase order, 40% of purchase at the time of shipment, 10% of purchase (plus freight charges) due net 30 days. If shipment is delayed beyond 30 days after the EQUIPMENT has been made ready for shipment, and the delay is caused directly or indirectly by the PURCHASER, then the total of the unpaid balance, at option of Quadrel, may become immediately due and payable upon written notice. Payments not paid when due shall thereafter bear monthly service charges at the rate of 1.5% per month on the unpaid balance until paid. If, in Quadrel's opinion, PURCHASER'S financial condition does not justify continuance of production or shipment on the terms of payment specified above, Quadrel may require payments in advance.

FINANCIAL IMPAIRMENT. Quadrel may, at its option, suspend performance if in its opinion the credit of the Purchaser becomes impaired until such time as Quadrel has received full payment, including any general price increases or surcharges, is satisfactory security for deliveries made and is satisfied as to Purchasers credit for future deliveries. Quadrel reserves the right to cancel Purchaser's credit at any time for any reason. In addition, Quadrel reserves the right by written notice to cancel any order or require full or partial payment or adequate assurance of performance from Purchaser without Liability to Quadrel in the event of:

- (a) Purchaser's insolvency
- (b) Filing of a voluntary petition in bankruptcy by Purchaser
- (c) Filing of an involuntary petition in bankruptcy against Purchaser
- (d) Appointment of a receiver or trustee for Purchaser
- (e) Execution by Purchaser of an assignment for the benefit of creditors

TAXES:

The amount of any present or future federal, state, local or other taxes applicable to the sale of EQUIPMENT shall be added to the price and paid by PURCHASER unless PURCHASER provides a valid exemption certificate acceptable to Quadrel and the appropriate tax authority.

GOVERNING LAW AND JURISDICTION. The sale agreement shall be governed and construed in accordance with the domestic laws of the State of Ohio without giving effect to any choice or conflict of law provision or rule that would cause the application of the laws of any jurisdiction other than the State of Ohio. Any legal action, suit or proceeding relating to the Sale Agreement shall be heard and determined exclusively in the United States District Court for the Northern District of Ohio or the Court of Common Pleas of Lake County, Ohio, and each party irrevocably submits to the jurisdiction of either such courts and waives any objection which such party may have to the laying of venue of any such legal action, suit or proceeding in any such court.

The Sale Agreement shall not be governed by the United Nations Convention on the International Sales of Goods. No actions arising out of the sale of Equipment or Services may be brought by either party more than one (1) year after shipment.

RETURNS:

EQUIPMENT sold by Quadrel is returnable only in accordance with the provisions hereof. Before returning of any EQUIPMENT or items thereof, PURCHASER must obtain Quadrel's written return authorization and instructions.

FORCE MAJEURE:

Quadrel shall not be liable for any loss, damage, delay, changes in shipment schedules or failure to deliver due to act of God, accidents, fires, strikes, riots, civil commotion, insurrection, war, the elements, embargoes, failure of carriers, inability to obtain electricity or other type of energy, transportation facilities, raw material, equipment or any problem or any similar or different contingency beyond its reasonable control which would make performance commercially impractical whether or not the contingency is of the same class as those above. Quadrel shall in no event be liable for any consequential damages.

TITLE AND RISK OF LOSS:

Title and risk of loss to EQUIPMENT shall pass to PURCHASER upon delivery by Quadrel to a common carrier, regardless of the freight terms stated or method of payment for transportation charges. Quadrel reserves the right to specify routing of shipments.

ENTIRE AGREEMENT:

This agreement embodies the entire agreement and understanding between the parties, is intended as complete and exclusive statement of terms of the agreement between the parties and supersedes any prior agreements or understandings between the parties relating to the subject matter hereof. PURCHASER acknowledges that Quadrel has not made any representations to PURCHASER other than those which are contained herein. Except as provided in this agreement, no change in or addition to the terms contained herein shall be valid as between the parties unless set forth in writing which is signed by an authorized representative of both parties and which specifically states that it constitutes an amendment to this agreement.

The parties may use their normal commercial forms in connection herewith: however, any such forms shall be used for convenience only and any terms or provisions which may be contained therein inconsistent with or in addition to those contained herein shall have no force or effect whatsoever between parties hereto.

EFFECTIVE:

This proposal is based upon the current cost of labor and materials and shall remain in effect for a period of sixty (60) days from the date hereof unless revoked by Quadrel in writing prior to acceptance.

INDEMNIFICATION:

The purchaser of this product ("Customer") hereby agrees to release, indemnify and hold harmless Quadrel and its agents, assignees and representatives for any and all liabilities, losses, costs, damages and expenses (including attorneys' fees and expenses) arising, directly or indirectly, from any and all manner of claims, demands, actions and proceedings that may be instituted against Quadrel on any grounds.

The Customer agrees to, at the Customer's own expense, promptly defend and continue the defense of any such claim, demands, actions or proceeding that may be brought against Quadrel, provided that Quadrel shall, within thirty (30) days of Quadrel receiving notice thereof, notify the Customer of such claims, demand, action or proceeding.

Quadrel shall at all times retain the right to defend itself and/or to otherwise participate in the defense of any such claim or action, and no settlement or other resolution of any such claims or action shall be finalized without Quadrel's written approval. Any failure by Quadrel to give prompt notice or provide copies of documents or furnish relevant data shall not constitute a defense in whole or in part to any claim by Quadrel against the Customer except to extend that such failure by Quadrel shall result in a material prejudice to the Customer.

The forgoing notwithstanding, if suit shall have been against Quadrel and the Customer shall have failed, after the lapse of a reasonable time after written notice to it of such suit, to take action to defend the same. Quadrel shall have the sole right to

defend the claim and shall be entitled to charge the customer with the reasonable cost of any such defense, including reasonable attorney's fees, and Quadrel shall have the right, after notifying but without consulting the Customer, to settle or compromise such claim on any terms reasonably provided by Quadrel.

This release and indemnification is and shall be binding upon the Customer, as well as the Customer's respective heirs, subsidiaries, affiliates, successors, assigns, agents and employees. If any provision or provisions of this release and indemnification shall be held to be invalid, illegal or unenforceable for any reason whatsoever, the validity, legality and enforceability of the remaining provisions of this Agreement shall not in any way be affected or impaired thereby. No supplement, modification or amendment of this Agreement shall be binding unless executed in writing by all of the parties hereto.

Any order put on hold or left dormant for any reason for 90 days will be considered cancelled. See Cancellation Policy below.

CANCELLATION POLICY:

In the event of order cancellation, the 50% down payment is non-refundable. Customer may also be responsible for additional charges covering engineering resources expended and committed materials depending upon the custom nature of the project and the point in the order process in which the cancellation occurs.

NOTE. No salesman, representative or agent of Quadrel is authorized to give a guarantee, warranty or make any representation contrary to above.

Please sign and acknowledge acceptance to these terms and conditions _____ Date _____

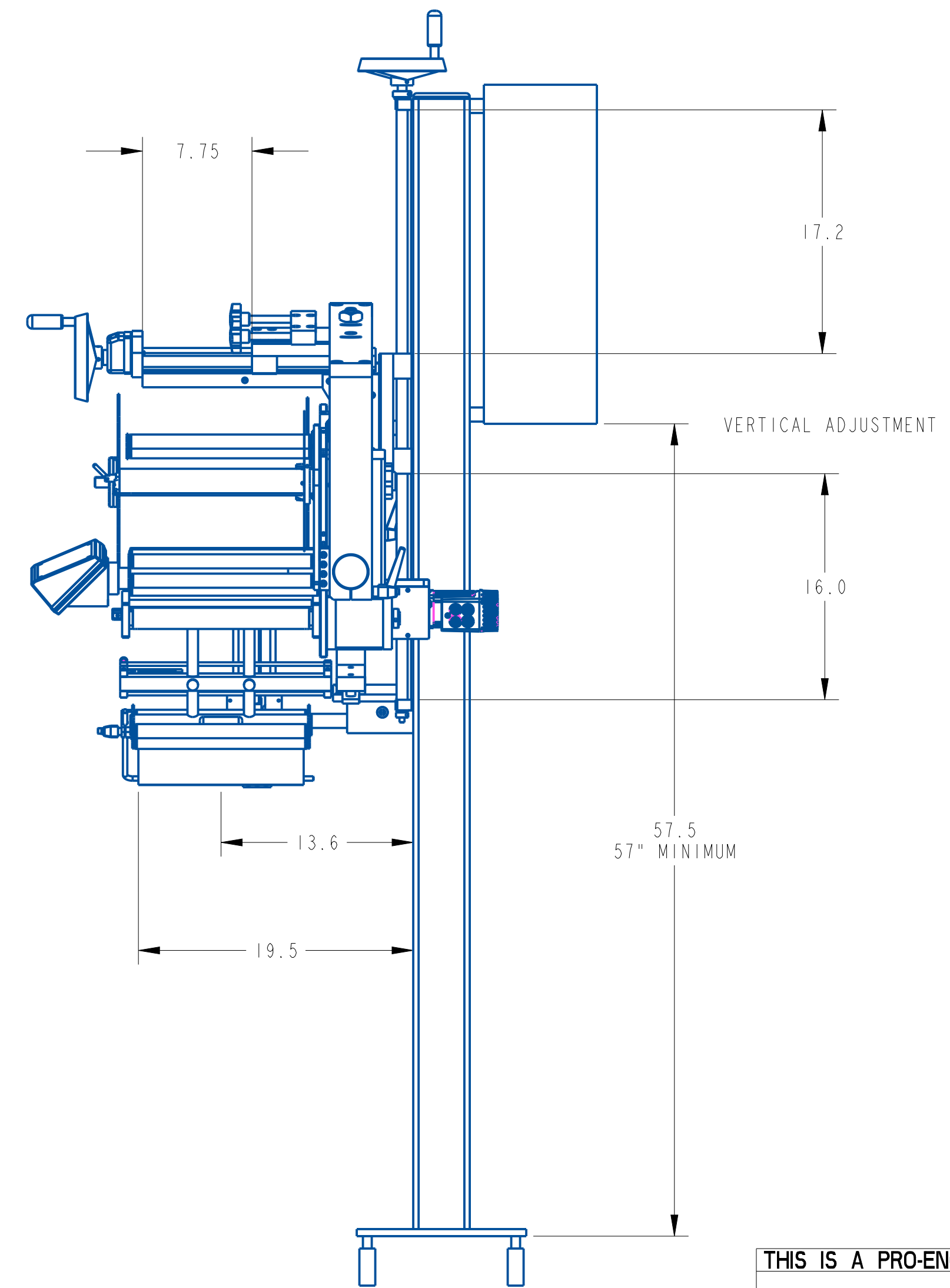
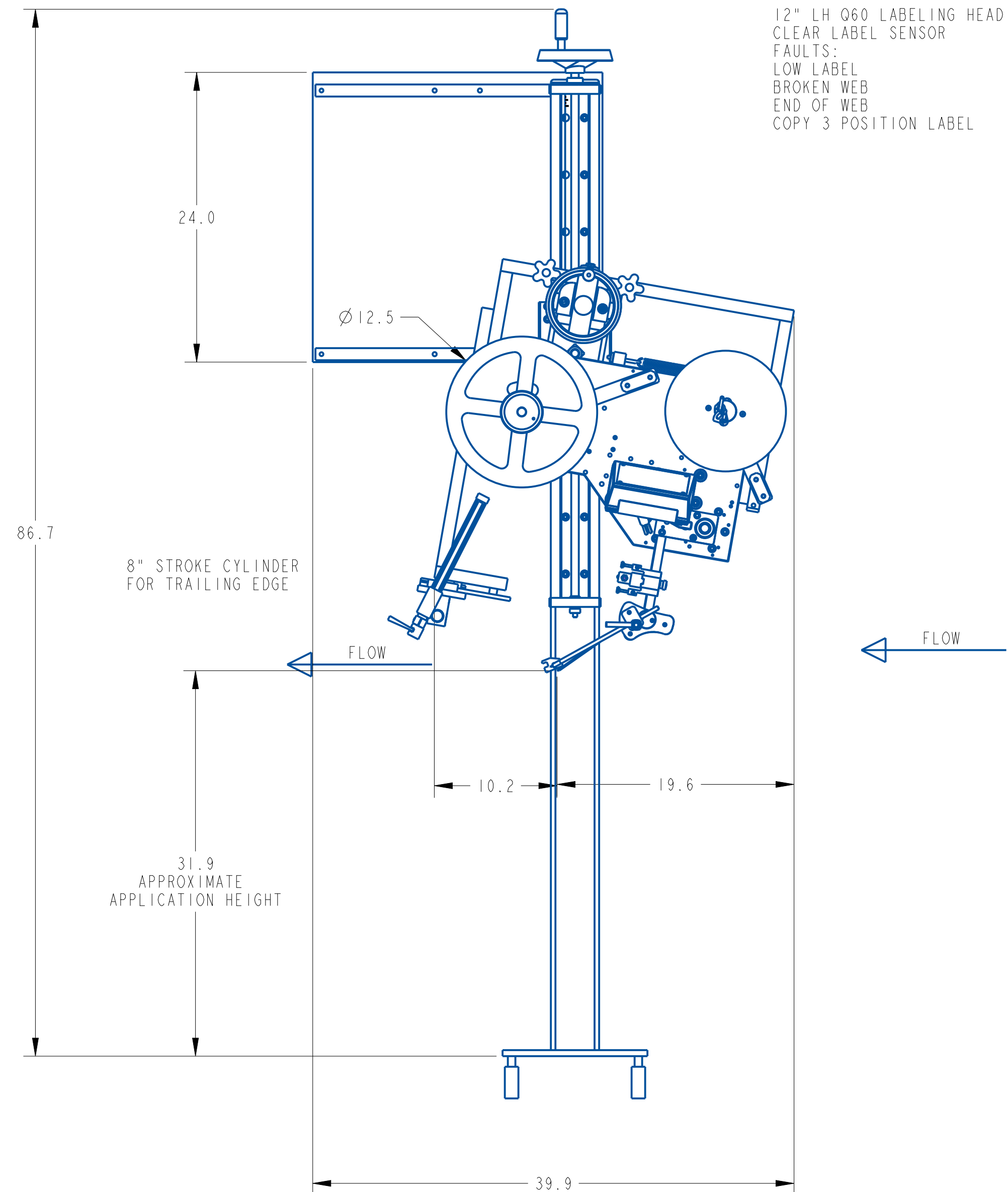
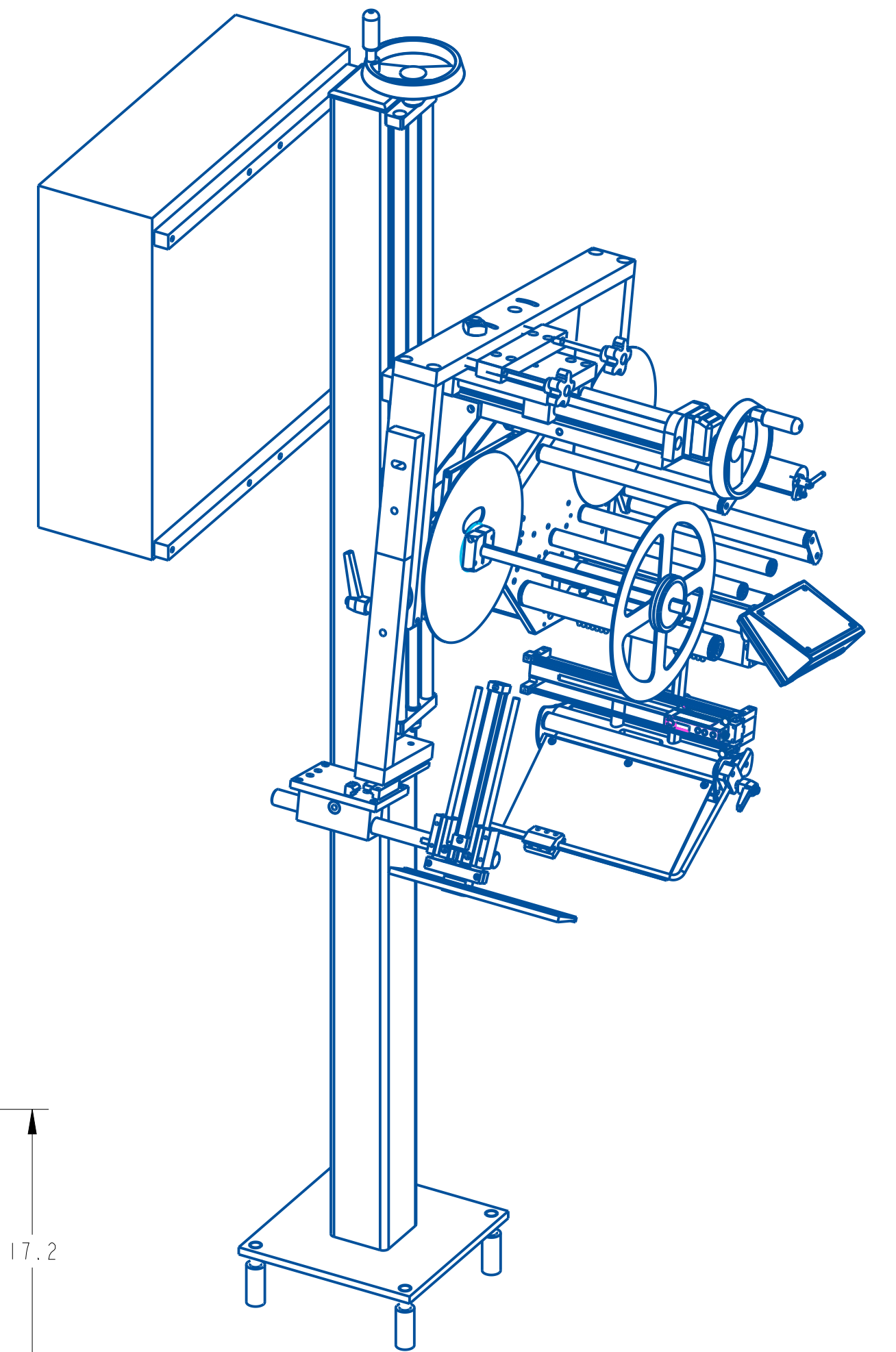
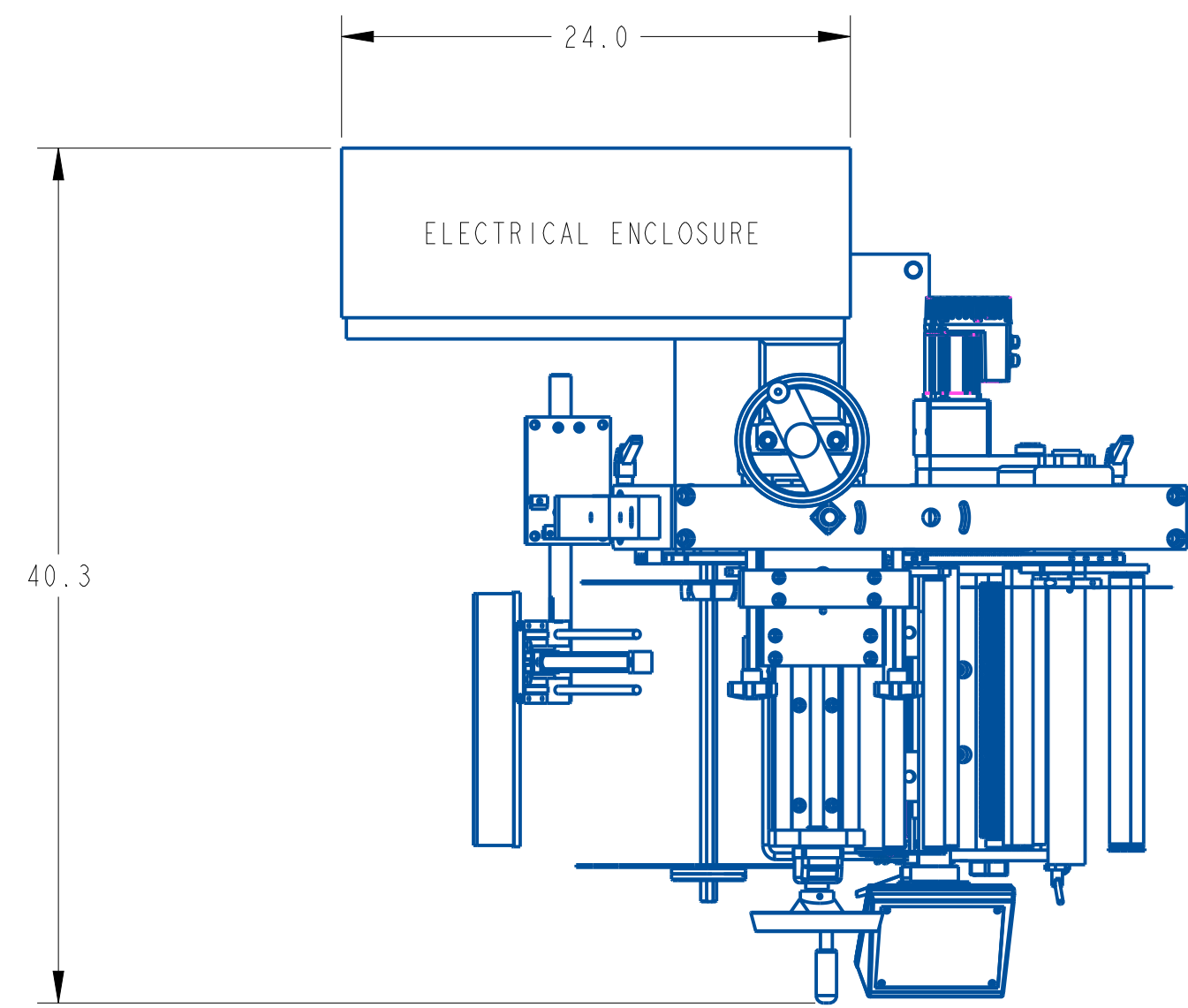

SHEET 1 OF 1

REV	DATE	DESCRIPTION	BY
A	Feb-19-25	NEW DRAWING	TAZ

THIS IS A PRO-ENGINEER DOCUMENT AND MAY NOT BE MODIFIED MANUALLY

UNLESS OTHERWISE SPECIFIED
 DIMENSIONAL TOLERANCE
 .x ± .1
 .xx ± .01
 .xxx ± .005
 ANGLES ± 30'

SURFACE FINISH 125
 BREAK ALL EDGES .005/.015
 CORNER RADIUS .010/.030
 ALL ANGLES ARE 90°

QUADREL LABELING SYSTEMS
 7670 JENTHER DRIVE
 MENTOR, OHIO 44060
 (440) 602-4700

SCALE: 1/8
 DATE: Feb-19-25
 DRW BY: TAZ
 CHK BY:
 APPR BY:

12" Q60 LABELING SYSTEM

MAT'L ENVIROTEX/MEDIKA PLASTICS LTD
 APPROVAL DRAWING

84127-100

TABLE OF CONTENTS

1	MANUAL PREFACE
2	GENERAL DISCRPTION
3	WARNING/CAUTION SAFETY INSTRUCTION
	3.1 SAFETY INTEGRATION
	3.2 GENERAL SAFETY INFORMATION
4	INSTALLATION / REASSEMBLY INSTRUCTIONS
5	HMI GUIDE
6	SET UP SHEETS
7	LABELING HEAD
	7.1 LABELING HEAD INFORMATION
	7.1.1 LOADING AND UNLOADING STOCK ROLL
	7.1.2 THREADING DIAGRAMS
	7.1.3 LABELER ADJUSTMENTS
	7.1.4 FUNCTION, OPERATION, & TROUBLESHOOTING
	7.2 SIDE PLATE ASSEMBLY
	7.2.1 ASSEMBLY WRITE UP
	7.2.2 DRAWING
	7.3 UNWIND ASSEMBLY
	7.3.1 ASSEMBLY WRITE UP
	7.3.2 DRAWING
	7.4 PEEL PLATE ASSEMBLY
	7.4.1 ASSEMBLY WRITE UP
	7.4.2 DRAWING
	7.5 BRUSH IMPRESSER ASSEMBLY – (OPTIONAL)
	7.5.1 ASSEMBLY WRITE UP
	7.5.2 DRAWING
	7.6 DRIVE AND PINCH ROLL ASSEMBLY
	7.6.1 ASSEMBLY WRITE UP
	7.6.2 DRAWING
	7.7 STEPPER/SERVO MOTOR DRIVER ASSEMBLY
	7.7.1 ASSEMBLY WRITE UP
	7.7.2 DRAWING
	7.8 REWIND ASSEMBLY
	7.8.1 ASSEMBLY WRITE UP
	7.8.2 DRAWING
	7.9 SLOT SENSOR ASSEMBLY
	7.9.1 ASSEMBLY WRITE UP

- 7.9.2 DRAWING
- 7.10 LABELING HEAD FAULTS – **(OPTIONAL)**
 - 7.10.1 ASSEMBLY WRITE UP
 - 7.10.2 DRAWING
- 7.11 PRODUCT DETECT ASSEMBLY
 - 7.11.1 ASSEMBLY WRITE UP
 - 7.11.2 DRAWING
- 7.12 STAND – **(OPTIONAL)**
 - 7.12.1 ASSEMBLY WRITE UP
 - 7.12.2 DRAWING
- 7.13 YOKE ASSEMBLY –**(OPTIONAL)**
 - 7.13.1 ASSEMBLY WRITE UP
 - 7.13.2 DRAWING
- 8 ELECTRONICS
- 9 MAINTENANCE
 - 9.1 GENERAL INFORMATION
 - 9.2 BELTS
 - 9.3 ROLLERS
 - 9.4 SENSORS
 - 9.5 CONVEYOR
 - 9.5.1 CLEANING
- 10 WARRANTY



Quadrel Labeling Systems Quality Manual

Quality Statement:

Quadrel Labeling Systems strives to provide our customers with the highest quality labeling/sleeving solutions available on the market. In order to achieve total customer satisfaction, we shall adhere to the following objectives:

100% on-time delivery

zero defects

Value added service and support

Engineered solutions

Employee development and diversity

We will commit to continuously improve each facet of our business operations through implementation of, and compliance of this manual.

A handwritten signature in black ink that reads "C. Wepler".

Chuck Wepler
General Manager / President

1 MANUAL PREFACE

Thank you for choosing Quadrel Labeling Systems. We have designed and manufactured this equipment with the upmost pride and care ensuring you the absolute best quality, maximum versatility and reliability.

This equipment is intended to be used only as described in this document. Quadrel Labeling Systems Inc. cannot be held responsible for the improper use or functioning of non-described functions of this machinery. Liability for any personal injury, loss of production or revenues, or property damage occasioned by the use of this manual in effect maintenance, operation, or repair of the equipment is in no way assumed by Quadrel Labeling Systems Inc. Anyone one using a procedure not recommended by the end user should first completely satisfy himself/herself that personal safety and equipment integrity will not be jeopardized in the method selected.

DO NOT attempt to install, operate, or adjust the labeling system without first reading and understanding the contents of this manual.

Only a trained person is to be permitted to operate this equipment. Training should include instruction in operation under normal conditions and emergency situations. Under no circumstances should an untrained person operate this machine.

This manual will provide operating instructions, parts listing and schematics. The information contained in this manual will help the user in his/her operations, troubleshooting, and maintaining the machine in good operating conditions. Information, illustrations and specifications contained in this manual are based on the latest product information available at the time of this manual release. Quadrel Labeling Systems Inc. reserves the right to alter and substitute information contained herein at any time.

Due to the customization it is also possible that you have received a different variation of this equipment, with several different options. Some pictures used in this manual may not totally reflect your configuration, although the labeling is completely the same.

All rights reserved while every precaution has been taken in the preparation of this manual, Quadrel Labeling Systems Inc. cannot be held responsible for errors, omissions, damages, loss of production, or revenues resulting from the use of the information contain herein.

3 WARNING/CAUTION SAFETY INSTRUCTION

Where safety is dependent upon starting or stopping devices, or both, they are to be kept free of obstructions that could endanger personnel.

The areas around loading and unloading points are to be kept free of obstructions that could endanger personnel. Instruct personnel working on or near this equipment as to the location and operation of pertinent stopping devices.

This equipment is to be used only for the purpose for which it is constructed.

Under no circumstances are the safety characteristics of this equipment to be altered.

Conduct routine inspections and corrective / preventive maintenance measures to ensure that all guards are installed and function properly. Alert personnel to the potential hazards indicated by the safety labels on this equipment.

3.1 SAFETY INTEGRATION

The end user's safety risk assessment will be the guiding document for proper integration of the equipment provided. Consideration of the following guidelines is recommended in order to achieve a safe result:

- Open areas under the equipment are to be guarded by the end user to prevent entry.
- Where conveyor flight lugs or product enters or exits the equipment, proper guarding and interlock are put in place by the end user to ensure mitigation of shear/jam points.
- The end user is responsible for properly guarding drive components on equipment that requires mechanical drive integration.

3.2 GENERAL SAFETY INFORMATION

This Quadrel Labeling System is engineered to feed and apply labels on your products. In designing the device, Quadrel valued personal safety; however we would like to draw your attention to the following safety acknowledgments.

 **WARNING** Hazards or unsafe practices, which **COULD** result in severe personal injury or death.

 **CAUTION** Hazards or unsafe practices, which **COULD** result in minor injury

 **CAUTION** The presence of safety systems in these units does not exempt the operators to act cautiously, avoiding behaviors that could

endanger their health or the equipment. These models are engineered to feed and apply labels on your products. In designing this device, Quadrel valued personal safety; however we would like to draw your attention to the following safety acknowledgments.

- Operators should know the basic operations and setup procedures before operating this equipment.
- Safe operations should be maintained at all times.
- Know the location of E-stops and power switches prior to operating machinery such as this.

 **WARNING**

To reduce risk of fire, electrocution, or other personal injury when operating. Follow basic safety precautions, including the following:

- This equipment must have an operator attending the machine at all times to monitor the operations. **DO NOT** leave this equipment unattended during maintenance or perform any maintenance unless the e-stop condition has been activated or power turned off.
- The electrical power to device is: ___220___ Volts, ___SINGLE (1)_Phase, ___60___Hz, ___15___Amps. While installing make sure it's properly configured and connected by a qualified electrical technician.
- **DO NOT** by pass any of the safety circuits or safety features designed into this equipment.



- ALWAYS turn off **power and pneumatics** before performing repairs.
- The doors on all electrical enclosures must be closed. All covers on labeling heads must be on labeling heads. (if applicable)
- This device is built to perform in humid conditions, but must not be pressure washed. Wiping down the device is the recommended cleaning method.



- Do not stand, sit, or allow any personnel to be within reach of the tamp cylinder/ swing arm activation (if so equip).
- Report any malfunctions, or problems with the equipment to qualified maintenance personnel for repair or adjustments that may be required.
- Keep hands clear of moving parts. Do not place hands near labeling head when in operation.



For systems containing conveyors, you must be vigilant with loose clothing or bodily parts as they can get caught in the conveyor's belt or chains as direct injury or death can incur. **DO NOT** use the conveyor as a working platform or walkway.

TUCK IN ANY LOOSE CLOTHING. DO NOT WEAR TIES. PENDANTS, JEWELRY OR ANY OTHER ARTICLE OF CLOTHING OR ACCESSORY THAT MAY GET CAUGHT ON ANY PORTION OF THE SYSTEM.

FOR PROLINE SYSTEMS ONLY

CASTERS WERE IMPLEMENTED FOR EASE OF SHIPPING PURPOSES ONLY. PLEASE USE CAUTION WHEN MOVING PROLINE THROUGH FACILITY. THE PROLINE RECOMMENDED USE: SET IN PLACE/POSITION WITH LEVELING PADS DOWN TO SECURE.

WARNING

- 1. READ AND UNDERSTAND THE OPERATION MANUAL AND ALL SAFETY LABELS BEFORE OPERATING THIS MACHINE.**
- 2. ONLY A TRAINED PERSON IS TO BE PERMITTED TO OPERATE THIS MACHINE. TRAINING SHOULD INCLUDE INSTRUCTION IN OPERATION UNDER NORMAL CONDITIONS AND EMERGENCY SITUATIONS.**
- 3. THIS MACHINE IS TO BE SERVICED ONLY BY TRAINED AND AUTHORIZED PERSONNEL. FOLLOW LOCK-OUT PROCEDURES BEFORE SERVICING.**
- 4. NEVER REACH INTO THE MACHINE FOR ANY REASON UNLESS THE MACHINE IS AT A COMPLETE STOP.**
- 5. NEVER LEAVE THE MACHINE STOPPED IN SUCH A MANNER THAT ANOTHER WORKER CAN START THE MACHINE WHILE YOU ARE WORKING ON OR WITHIN THE MACHINE.**
- 6. NEVER CHANGE OR DEFEAT THE FUNCTION OF ELECTRICAL INTERLOCKS OR OTHER MACHINE "SHUTDOWN" SWITCHES.**
- 7. BEFORE STARTING THIS MACHINE, CHECK THAT: ALL PERSONS ARE CLEAR OF THE MACHINE; NO MAINTENANCE WORK IS BEING PERFORMED ON THE MACHINE, ALL GUARDS ARE IN PLACE.**
- 8. ROUTINE INSPECTIONS AND CORRECTIVE/PREVENTATIVE MAINTENANCE MEASURES ARE TO BE CONDUCTED TO ENSURE THAT ALL GUARDS AND SAFETY FEATURES ARE RETAINED AND FUNCTION PROPERLY.**

Using VFDs On GFCI Devices

By Bill Szatkiewicz, Senior Software Engineer
KB Electronics

for more information, email: info@kbelectronics.net
or visit: www.kbelectronics.com

The National Electrical Code, or NEC, continues to expand protection requirements for safety reasons resulting in an increase in Ground-Fault Circuit-Interrupter (GFCI) outlets being used in more environments. As a result, the Variable Frequency Drives (VFDs) industry is finding more instances of VFDs being powered from GFCIs. VFDs introduce high frequency harmonic content which may cause nuisance tripping on some GFCI devices. This paper is intended to assist anyone that needs to use a VFD on a circuit with GFCI protection. KB Electronics has developed special VFDs suitable for use with most GFCIs*.

* Please contact KB Electronics with information regarding your specific GFCI.

What is a VFD?

A VFD (also termed adjustable frequency drive, variable speed drive, AC drive, adjustable speed drive, micro drive, motor control, or inverter drive) is a power conversion device that will accept normal fixed branch circuit voltage of (115V or 230V) and frequency (50 Hz or 60 Hz) and allow the operator to control the speed of an induction motor (AC Motor) by varying the output voltage and frequency. A simplistic version of a typical VFD system is shown in Figure-1.

In addition to operator controllability, the VFD with soft start/stop features offers extended equipment life, increased performance, reduced maintenance, protection from excessive currents and voltages, as well as energy savings.

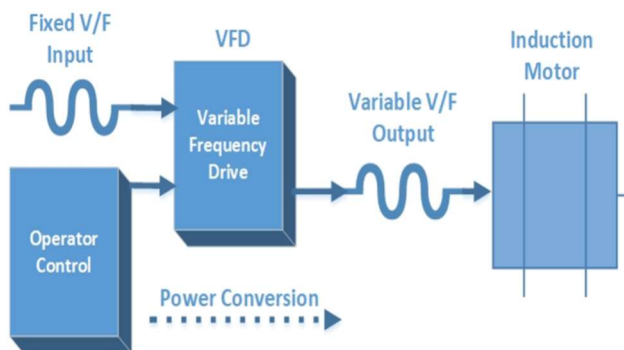

Figure-1: Typical VFD System

What is a GFCI?

A GFCI (shown in Figure-2) is a circuit breaker device which is designed to protect people from hazardous shock or electrocution by shutting off an electric power circuit when it detects current flowing in a way that it is not meant to, such as through water or a person.



Figure-2: Typical GFCI Outlet

The GFCI is intended to protect people from electrical shock, therefore, it is completely different from a fuse in the sense that it needs to shut off the electric power circuit at a low current, typically no more than 5 mA, in a quick amount of time (less than 1/10 of a second).

The GFCI does this by measuring and comparing the amount of current flowing in the ungrounded (hot) and grounded (neutral) conductors of the circuit. If the GFCI detects an imbalance in the circuit, it immediately shuts off the circuit.

Why Nuisance Trips Occur with Standard VFDs

Standard VFDs, when powered from GFCI outlets, can cause the GFCI to trip due to the leakage currents generated from the high switching frequency of the VFD's power devices and the harmonics associated with them. These high frequency leakage currents are not at the base frequency of the drive output which is normally 50 Hz or 60 Hz. These high frequency leakage currents, typically greater than 4 kHz, may cause the GFCI to trip because the GFCI is designed to work with 50 Hz or 60 Hz frequency inputs, not this higher value.

The high switching frequency of the VFD's power devices induce more capacitive-coupled currents, since a capacitor approximates a short circuit at high frequencies. This creates common-mode noise, referred to as leakage current, which travels through ground and can cause the GFCI to trip. The path to ground is made through the motor bearings or auxiliary equipment bearings.

In addition to the high switching frequency of the drive, there can be many other contributing factors which cause the GFCI to trip. Some drives have built-in filters which couple additional leakage current to earth ground. Other drives use external filters and replacing them with a low leakage filter may help.

One way to help determine if the GFCI tripping is occurring from the input filter or the VFD output is to remove either the input filter or the motor and observe if the GFCI still trips. For example, if the input filter is easily removed and doing so

prevents the GFCI from tripping, the source of the leakage currents tripping the GFCI was largely from the input filter.

Another method is to disconnect the motor. If doing so prevents the GFCI from tripping the contributing source of leakage current is most likely from the output stage of the VFD. However, most often than not, the GFCI is tripping from a combination of the two and improvements on both the input and output will help.

Long motor power cables can also create noise spikes. These long leads add more capacitance which increases noise spikes from the fast switching power devices of the VFD. Use a VFD rated cable with the shortest leads possible when connecting the motor power cables. A choke on the VFD's motor outputs may help reduce noise spikes.

In addition, ensure that motor cables are properly shielded, sized, routed, terminated, and grounded at both the motor and drive.

KB's GFCI Solution

KB's engineering team has studied VFDs powered from a variety of GFCI devices. A solution has been created which considers all contributing factors to get a best-case scenario that successfully works with most GFCIs.

KB investigated switching frequencies and developed custom switching frequency algorithms to reduce audible noise and leakage currents. High frequency noise spikes and ringing were reduced by modifying our proprietary power circuits for optimal results. In addition, output chokes, low leakage filters, and shielded cable were introduced, if needed, to find a GFCI solution.

Conclusion

KB has had great success providing VFDs that work with GFCIs for numerous original equipment manufacturers (OEMs). KB offers a full range of motor controls (shown in Figure-3) which can be customized to work with GFCIs. Let KB Electronics provide a solution for you.



Figure-3: VFDs Available from KB Electronics

Unboxing & Installation of your Quadrel Labeling Systems Machine

This section of your manual is aimed towards making the transition from Shipping Crate to Assembly line less Dramatic. If you have scheduled an install with one of our Professional Technicians the set-up of your machine will be a breeze. If not your manual as all of the information needed to get you going. In this section there may be some equipment shown that does not apply to the machine you purchased.

NOTE This is general instruction for all equipment (your equipment may vary slightly).

Let's get started...

First things first, check your crate/box/machine for damage. If there is damage please note the exception and contact Quadrel immediately. Any extra boxes or pallets will be either in your crate or tethered to the crate or pallet. Once you have inspected your shipment you can open the crate. Check packing slip Bill of lading against boxes received. Notify Quadrel of any discrepancies.



Carefully remove all banding on the legs, misc. boxes and assemblies in the crate or on the pallet. If your machine is



wrapped in bubble wrap or plastic wrap go ahead and carefully cut and remove that as well. Ensure you are wearing the appropriate safety gear when removing your machine from the crate.



Ensure all plastic wrap is removed from the assembly you are removing the support from before removing the support.

Remove the supports under your labeling heads, wrap station, top trap, HMI, Pacing wheel or belt. See images for various supported assemblies.



Most assemblies supported have a tool-less vertical adjustment using a knob or hand wheel.

The hand wheel may be wrapped to the assembly to prevent damage.

Remove the hand wheel from the wrap, then fasten the hand wheel to the square end on the lead screw using a 3/32 "L" handle Allen wrench.

Turn the handle/knob to raise the assembly this will take the weight off the supports so you can remove them.

Top Trap Support (top) Labeler Head Support (bottom) Plastic wrapped hand wheel (right)

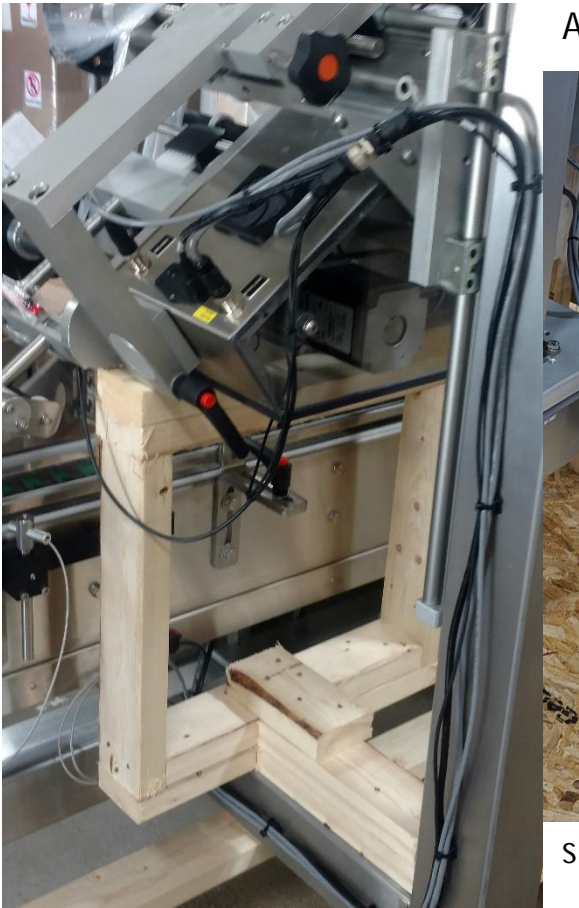

All top and bottom labeling heads will be supported

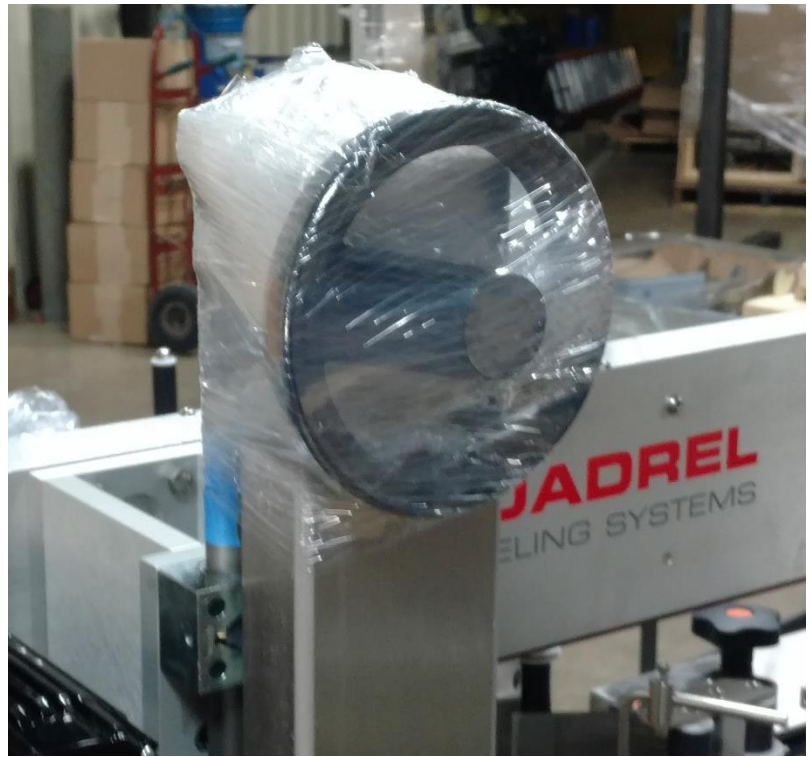

similar to the image shown on the left.

Wrap stations will have supports similar to the image to the right. These supports do not require moving the assembly.

Pacing belt assembly supports can be removed without raising the assembly.

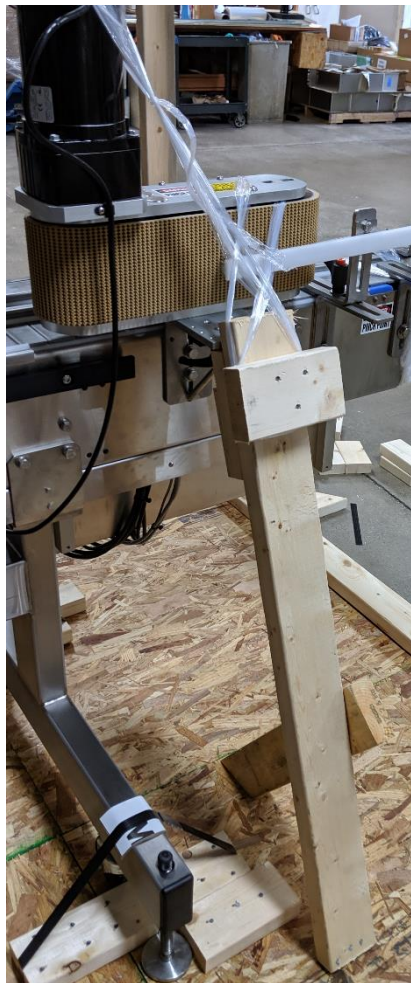

Pacing wheels supported as shown

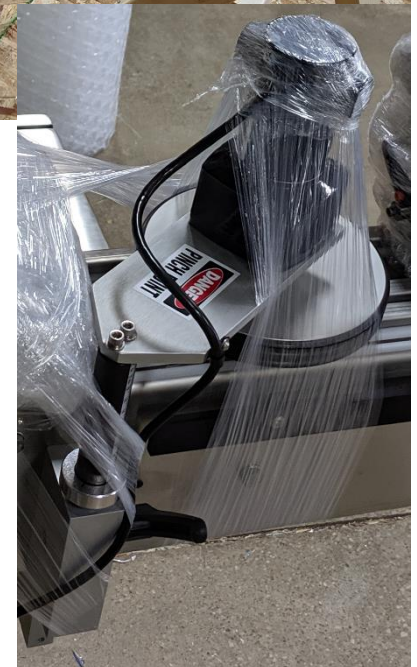



Often the head support will be moved in shipping or moved to be supported. When you are setting up your machine refer to your set up sheet in this manual. There are scales on the side of the assembly to line the carriage up to (as shown in the Image to the left and below).

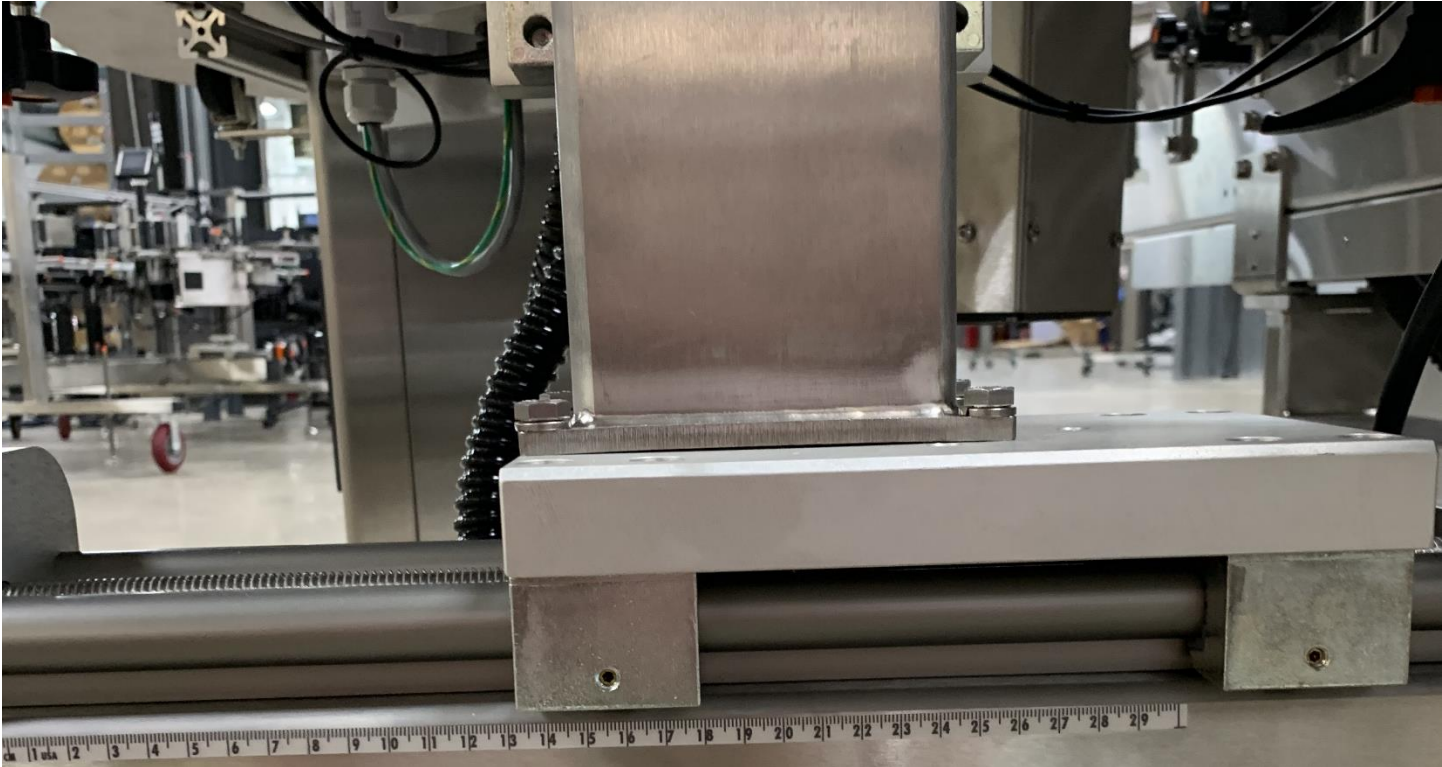

Peel plates with or without the rods may be removed from the labeling head to move the head all the way in during shipping.

All assemblies removed will be bubble wrapped then plastic wrapped to the machine (as shown in image on the right) or in box on the pallet the machine is on (as shown in image below).



Mount the peel plate assembly using a 5/16 L handle Allen wrench (as shown in image on the left). The bolts are located in the assembly. You simply put the wrench in the quick change access holes to loosen or tighten the assembly.

NOTE When you are setting up your machine make sure the peel plate assembly is perpendicular to the conveyor. When the peel plate assembly is on the rods there is a small amount of play allowing you to make small adjustments to the assembly.

If you have the peel plate rods removed with the peel plate assembly and the label detect assembly (as shown below).

All assemblies removed will be bubble wrapped then plastic wrapped to the machine or in box on the pallet the machine is on.



First back the head out all the way. Locate your peel plate assembly and slide it into the holes in the drive roll assembly (as shown on the left of the image above). Make sure you take the bolts out of the end of the rods before putting them into the drive roll assembly.



Fasten the assembly to the drive roll with the bolts supplied using a 5/16 L handle Allen wrench. Make sure you have the lock washers on the bolts.

NOTE When you are setting up your machine make sure the peel plate assembly is perpendicular to the conveyor. When the peel plate assembly is on the rods there is a small amount of play allowing you to make small adjustments to the assembly.

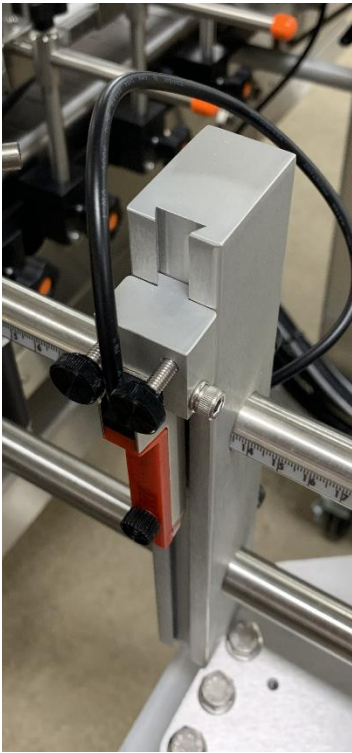

When the peel plate rods are removed the label detect sensor is removed with it (shown in image to the left). The sensor is locked into place so it won't move or need adjusted. All that will need done is simply reconnect the sensor to the zip port. To re-connect the sensor first locate the zip port (as shown in image on the right). The zip port is located under the head on the chassis or mounting plate. Take the cable coming from the sensor, route it neatly under the head, and screw it into the zip port where it says "label detect".



Some machines may have the unwind flange (shown in image to the right) removed to protect the flange during shipping do to the width of the machine.

All assemblies removed will be bubble wrapped then plastic wrapped to the machine or in box on the pallet the machine is on.

First, slide the unwind flange (with the collar facing towards you as shown in image to the right) over the unwind shaft. Make sure the top of the flange is 1 ¼ inches off the side plate.

Then, lock into place by tightening the collar with a 5/32 L handle Allen wrench.

Slide the quick lock collar over the shaft by lining the set screw up with the flat. The collar locks into place by rotating the collar 90 degrees.



Some machines may have the rewind flange (shown in image to the right) removed to protect the flange during shipping do to the width of the machine.



All assemblies removed will be bubble wrapped then plastic wrapped to the machine or in box on the pallet the machine is on.

First, slide the rewind flange (with the collar facing away from you as shown in image to the right) over the rewind hub make sure the flange just above the rubber bumper roughly 1/2 inch off the side plate.

Then, lock into place by tightening the collar with a 5/32 L handle Allen wrench.

Rails and transfers on the infeed and outfeed may be removed for shipping purposes. They will be wrapped in bubble wrap and wrapped to the machine. Carefully remove wrap and place in position as shown lock into place by tightening the knobs or ratchet handles.

NOTE Your machine may have a different rail system either adjustment is tool-less and fastened by a knob of ratchet handle.



End transfers will be wrapped in bubble wrap and plastic wrap. They will be located in a box on the pallet with your machine or wrapped to the machine itself.

Fasten the end transfer plate to the machine using a 5/32 L handle Allen wrench and the supplied 10-32 socket head screws. Ensure the transfer plate is both level with the conveyor and DOES NOT hit the conveyor chain.

Stack lamps are usually placed at the highest point of the machine and for that reason they are either removed or rotated 180 degrees. The stack lamp will be wrapped in bubble wrap and wrapped to the machine.

If the stack lamp is rotated then all you need to do is remove one of the bolts, rotate the stack lamp and put the screw back in. We use various screws on stack lamps you will need one of the following tools for the job.

- 3/32 L handle Allen wrench
- 1/8 L handle Allen wrench
- 5/32 L handle Allen wrench
- 3/16 L handle Allen wrench
- 1/2 open end wrench



HMI over head touch screen displays may be laid flat across the top of the enclosure wrapped in bubble wrap and plastic wrap.

Carefully remove the plastic wrap and bubble wrap.

Rotate the HMI 90 degrees and slide into the mount on the enclosure.

Fasten the pole in place by tightening the 2 set screws on the mount with a 6MM L handle Allen wrench.



The HMI may be enclosed in a wooden support off the enclosure to hold it in place during shipping.

If HMI is located remotely off the enclosure it will still be supported during shipping.

If so, carefully remove the supports and you are done.

All printers, printer controllers and lasers are removed from the machine when shipping and placed in the manufacturer's box. The cabling will remain on the machine for ease of installation.

The printer is mounted to the printer mount with 1 ¼-20 ratchet handle. Make sure you line up the indents in the plates with the brass nut on the threaded rod. Then slide the ratchet handle through the center of all of the blocks and tighten. Plug in the cables and you are done.



Table top printers with printer tables will ship in separate boxes or pallets (as shown to the left) the printer will be disconnected and placed in the manufacturer's box. The table will either get banded to the pallet with the machine or a separate pallet tethered to the machine pallet. Printer tables may be connected to the machine via weldment or a remote from machine. If you have a weldment connected table, refer to the lay out drawing of your machine in this manual. Fasten the weldment to the frame of the conveyor using the supplied hardware and an open end wrench. If the table is remote then move into the desired position referring to your layout drawing. Remove the printer from the box set on the table and plug in the pre-wired connectors.



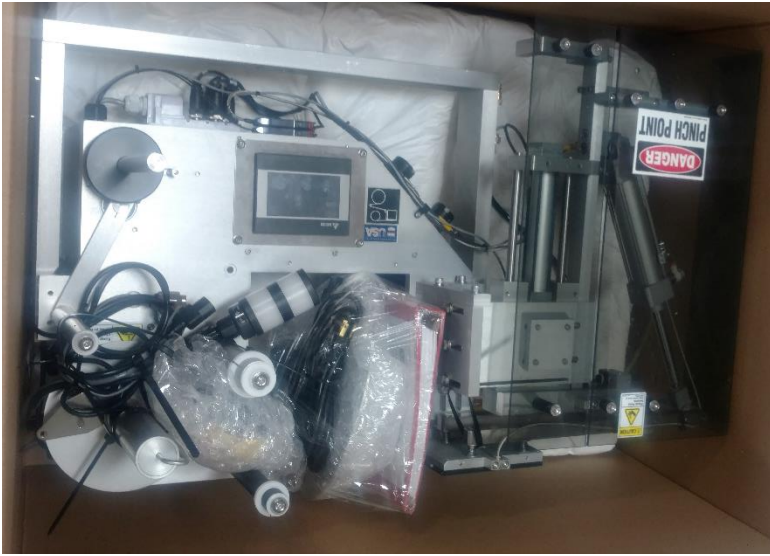

Print and apply printers will be removed from the labeling head as well and placed in the manufacturer's box. Your labeling head will likely ship in its own boxes with a few of the assemblies or flanges removed. Occasionally your head on a stand will ship on a framed pallet which will requires little work to get started.

The unwind flange is installed like the previous one discussed previously.

Remove the printer from the box and place it into the opening of the labeling head (as shown in image to the right). Fasten the printer to the side plate of the labeling head using the supplied (5) 10-32 socket head screws and a 5/32 L handle Allen wrench. Then, plug the printer in.



The corner wrap modules will be removed for shipping purposes. They will be wrapped in bubble wrap, plastic wrap, and placed into the box with the labeler.

Take out of the box, carefully remove the wrapping.

Then mount to the labeling head with (4) ¼-20 bolts using a 3/16 L handle Allen wrench.

To prevent kinking of the air lines during shipping on our q34 print and apply labeling heads. All lines are pulled and labeled to the corresponding color. The hoses are color coded and marked. Simply plug in hose into the matching color (as shown in image to the right).

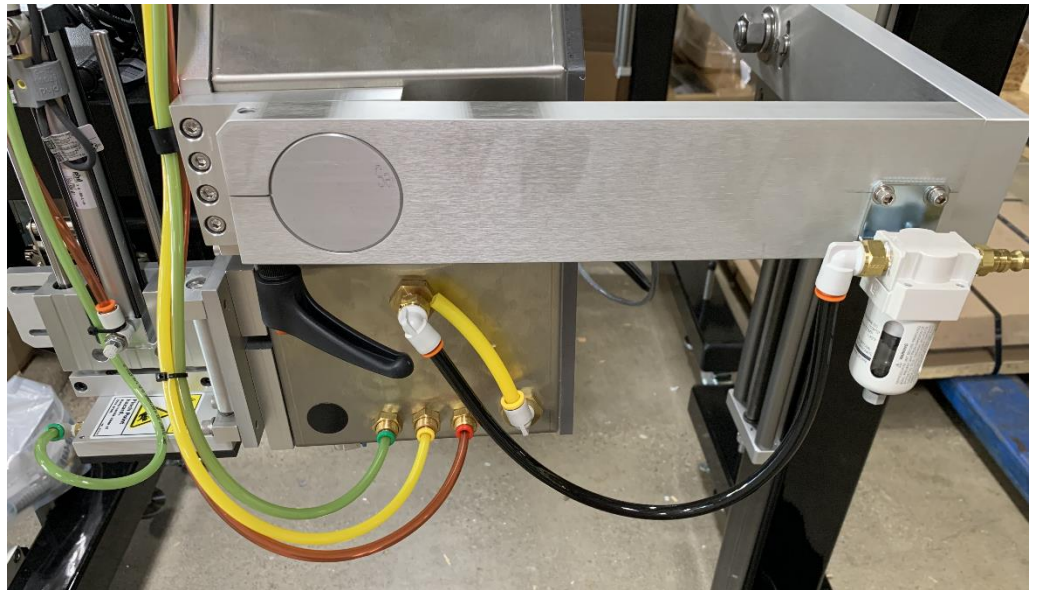

Rotary accumulation tables are banded to a pallet and wrapped.

These tables usually operate independently to the machine.

Carefully un-band and unwrap the table.

Line it up to the transfer plate on the conveyor.

Level the table using the leveling pads.

Plus in and adjust speed through the control box.



Sleeving applicators are typically on a stand and will ship on a pallet. They will be banded have many supports and be wrapped to protect the machine during the shipping process.

Carefully remove the banding and wrapping.

Raise the head and remove the supports.

The pallet will contain boxes with. Misc assemblies and or parts (ie mandrels).



Below is an image of the mandrel. The mandrel is the most precise and important part of the sleeve system. Always handle the mandrel extremely carefully.



Your mandrel will be located on the machine pallet tethered to the machine. It will be wrapped and in a box or tube (as shown below).

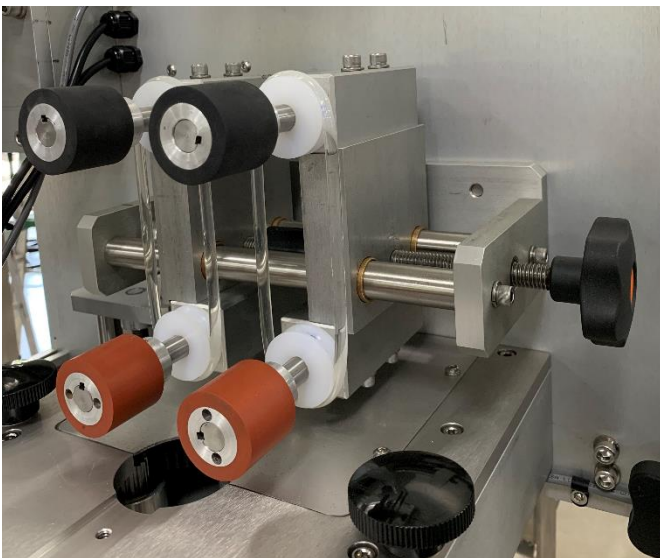

Carefully remove the mandrel from the packaging.

Rotate the black handle to move the throw down rollers apart far enough to slide the mandrel in.

Ensure each roller is between 2 bearings, the fin on the top is between the sensor, and the cutter blades are in line with the cut in the mandrel.

Rotate the black handle to move the throw down rollers closer to the mandrel pinching it in the middle. **DO NOT OVER TIGHTEN THE THROW**

DOWN ROLLERS INTO THE MANDREL. They need to be just tight enough that the bearing spins and a label feeds through.

Proline machines with guarding will either be left on the machine and have wooden supports to protect during shipping or the guards are removed and placed on a pallet.

If the guarding has supports carefully remove the supports from the guarding.

If the guarding is removed from the machine each panel will be labeled and the machine will be labeled to make it easy to figure out which door goes where.



The doors are fastened to the frame of the machine with the supplied hardware.

Line the hinges up to the holes on the frame put the bolt through.

Tighten a nut on the opposite end with the supplied flat and lock washer.





During shipment if the conveyor gets skewed you may need to re-square it. First check the conveyor with a square to verify (as shown in images below). If the conveyor needs adjusted, adjust the conveyor by slightly loosening the 4 bolts connecting the 2 sections on conveyor you would like to adjust (as shown in image to left).

Make your adjustments and check the top and side with a square. Placing a square across the top will check the squareness vertically. Placing a square along the side will check squareness horizontally.



When the conveyor is square tighten the bolts and you are all set.

When shipping a proline with an extended boom the dual swiveling elbows in the center of the boom get flipped 180 degrees to allow the machine to have enough over head clearance to ship safely (shown in image below).



Below are the instructions to flip the elbows to the correct configuration (as shown in image below)



Ensure the overhead controls are safely supported by a tow motor or at least 2 people so it does not fall when disconnecting the elbows.

Locate the 2 screws on the top and 2 screw on the bottom holding the prospective covers on.



With a t25 torx bit screw driver, loosen the 2 bolts holding the cover on the top and bottom.

With the cover off you can now access the 4 bolts holding each of the tubes in place.

Ensure the overhead enclosure is supported enough to hold for a few minutes while you loosen the bolts and flip the elbow.

Using a 6MM L handle Allen wrench loosen the 4 bolts on the top and bottom tube.



Quickly pull the tubes out and rotate the elbow as shown below.



BEFORE



AFTER

Slide the tubes in. the overhead enclosures elevation is going to change when flipping the elbows if you have it supported via tow motor you will have to raise it.

Fasten the 8 bolts with a 6MM L handle Allen wrench.

Fasten the covers to the top and bottom elbow using a T25 torx bit screw driver.



To the left shows the correct orientation of the dual elbow boom for the overhead enclosure.

If you have any questions please give our professional technicians a call.

FAMILY GUIDE



Operator Interface Guide

Custom Top Labeling System

84263_v000 Files

Keyence Nano PLC, Weintek Touch Screen, Applied Motion Servo

The overall system controls two sub-systems from a single cabinet and PLC.

Each sub-system contains:

- Dual side belts to transport products
- Gate at the infeed end of the belts to square up products
- Labeling head
- Wipe cylinder
- Operator Interface
 - Each operator interface only controls its specific sub-system. The only “global” control is that of Resetting the Safety Relay as the Reset button on either screen is used for this.

Table of Contents

Opening Splash Screen.....	3
Main Screen.....	4
Recipe Menu.....	6
Labeler Menu.....	7
Labeler Service Menu.....	9
System Setup Menu.....	11
Wipe Menu.....	12
User Menu.....	13
Password Menu:.....	14
Fault Messages and Indicators:.....	15
Warning Messages.....	15
Fatal Messages.....	16

Opening Splash Screen

Upon initial power up, the terminal will initialize and display a splash screen. Once the screen and PLC boot up, the “Touch Screen to Continue” text will appear. Touch the screen to continue.

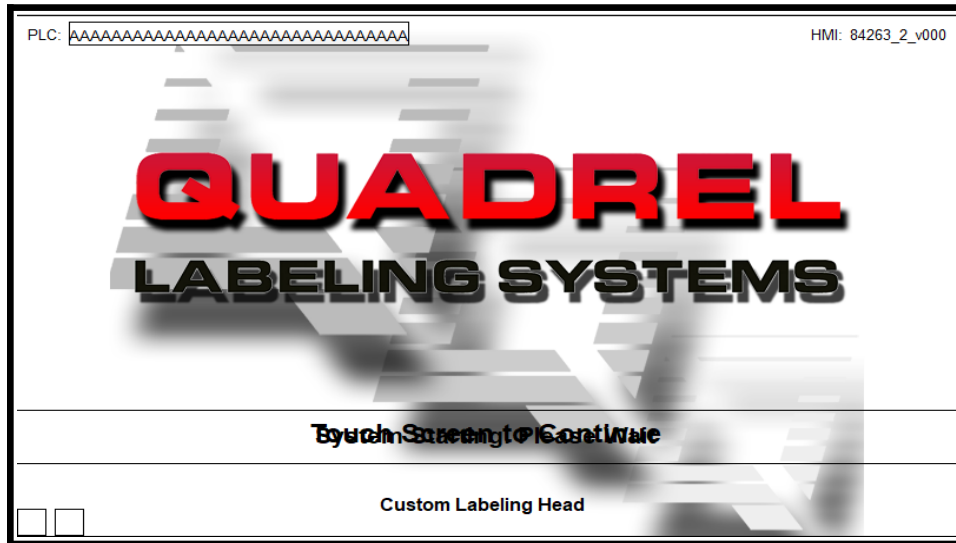

Button / Indicator Reference:

Menu Navigation Buttons: Navigation buttons will be purple circles with white outlines and icons of the target screen. Some buttons will have text below them to identify the target screen.

Standard Buttons: Standard buttons are used to turn features on/off, reset faults, clear counters, or various other functions that require operator control. Toggle buttons will typically have icons to reflect the status of the function that is being toggled while momentary buttons like Resets are circular and do not change images/colors. Many buttons and toggles may be password protected, which will appear differently if the current user does not have proper access.

Indicators: Status Indicators will be circular and will change color based on states. Mode indicators will be oval in shape and will change colors and texts based on states.

Numeric and Text Displays: Numbers or Text displays will have a light orange background with black text and be oval in shape.

Numeric and Text Inputs: If a number or text can be entered, the button will have a dark green background (typical, but colors can change) with white text. The right side of the button will have a touch icon signify that it is an entry box. All numeric entries will have the touch icon regardless of color.



Main Screen

After touching the splash screen, the touch screen will display the Main screen. You can also get to the Main screen by pressing the Home icon (pictured left).

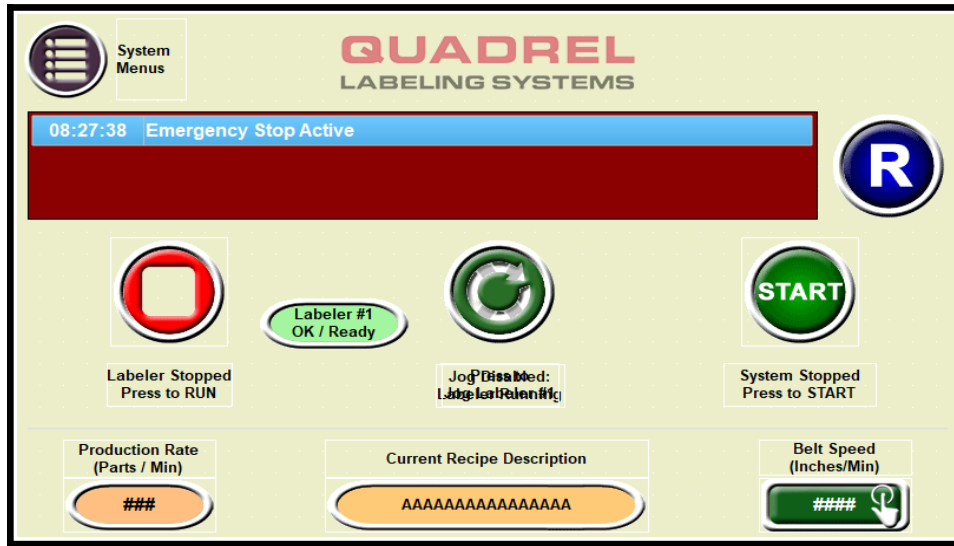

System Menus:

This button will expand the menu bar on the left side of the screen.

Fault/Message window:

Displays current alarms and status messages about the status of the labeling system.

The Faults Menu button can be used to display more messages or a history if needed. Pressing the Blue reset button will clear these messages if the fault was remedied.

Labeler Run/Stop:

The Labeler can be toggled between Run and Stop (pending fault conditions). The Run/Stop button will change colors and text based on the current status.



Green "Running" Button: This indicates the labeler is currently running and cannot be jogged. While running, the labeler will automatically apply labels to passing products. To **stop** the labeler, press this button.



Red "Stopped" Button: This indicates the labeler is currently stopped and may be jogged. While stopped, the labeler will ignore products passing by. To **run** the labeler, press this button.

Labeler Status Indicator:

The status indicator below the Run/Stop buttons will identify which fault state the labeler is in.

Green: Ready / OK. The labeler has no fault conditions and may operate normally.

Yellow: Warning. The labeler has a warning present (typically low on labels). The labeler may operate normally, but will require attention soon.

Red: Faulted. The labeler has a fault on it that will prevent it from dispensing labels.

Grey: Disabled. The labeler is disabled and all functions are bypassed.

Labeler Jog:

When the Labeler is stopped, the Jog button becomes available. Pressing the Jog button will cause the labeler to dispense one label (pending proper threading and label gap detection). It is important to jog labels upon threading or changing over to verify the labeler is threaded and functioning properly.



Green “Jog” Button: This indicates the labeler can be jogged. Press this button to start a jog process. This button will be grey while the labeler is jogging.



Greyed out “Jog” Button: This indicates the labeler is currently running, and may not be manually jogged.

System Run Mode:

The dual side belts can be stopped and started using this button.



Green “Start” Button: Pressing this button will start the system (assuming no fatal faults are present on the system).



Red “Stop” Button: Pressing this button will stop the system.

Product Rate (Parts Per Minute):

This indicator will reflect how many parts per minute are being labeled by the system. This number will average out over a period of time and may need at least 10 products in order to start calculating a rate.

Current Recipe Description:

This display reflects the description for the currently selected recipe. Recipes are explained in the Recipe Menu.

Belt Speed:

This entry box changes the speed of the dual side belts. It will be entered as inches per minute (100-1600).



Recipe Menu

This menu allows the user to select each labeler or recipe menus.



System Recipe:

Recipes are presets that contain parameters unique to each product. Setting Recipes for different products expedites changeover times. A total of 9 system recipes can be stored and descriptions can be changed when logged in at a Supervisor Level.

System Recipes store the following information:

Description

Belt Parameters: Belt Speed, Gate Delay, Gate Duration

Labeler Parameters: Product Delay, Label Stop, Max Feed, Speed Ratio

Wipe Parameters: Enable, Wipe Delay, Wipe Duration

Load Recipe:

Changing the Recipe number at the left will load the newly entered recipe to the system. **Recipes can only be changed while the Labeler is stopped.**

Current Recipe Description:

The description display at the top of the screen reflects the stored description for the recipe currently loaded on the system. When logged in at a Supervisor level, the change description button will appear which is used to enter a new recipe description.



Save Recipe (Supervisor Level):

The Pink Save button must be pressed to save all current values to the currently selected recipe.



Save As Recipe (Supervisor Level):

The current settings can be saved to a new target recipe. First change the Recipe to Save As number (when logged in at a supervisor level) and then press the Save As Recipe button in the bottom left. The description will automatically be copied, but will start in "Copy_" to identify it's a copied recipe.

Change Recipe Description (Supervisor Level):

Pressing the green box showing the Current Recipe description will bring up a keypad which is used to change the current description.



Labeler Menu

The Labeler Menu contains the parameters and controls associated with dispensing labels

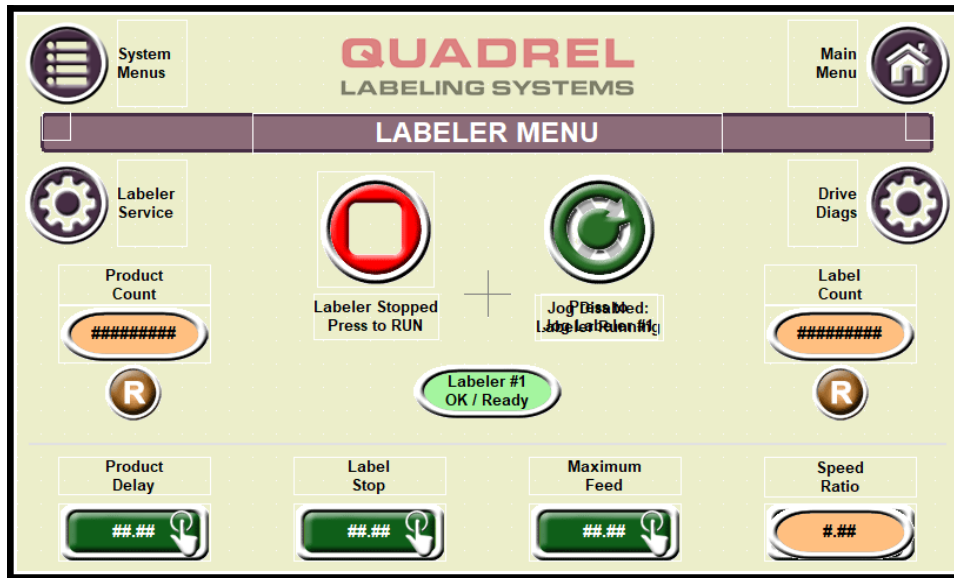

Labeler Run/Stop:

The Labeler can be toggled between Run and Stop (pending fault conditions). The Run/Stop button will change colors and text based on the current status.



Green "Running" Button: This indicates the labeler is currently running and cannot be jogged. While running, the labeler will automatically apply labels to passing products. To **stop** the labeler, press this button.



Red "Stopped" Button: This indicates the labeler is currently stopped and may be jogged. While stopped, the labeler will ignore products passing by. To **run** the labeler, press this button.

Labeler Jog:

When the Labeler is stopped, the Jog button becomes available. Pressing the Jog button will cause the labeler to dispense one label (pending proper threading and label gap detection). It is important to jog labels upon threading or changing over to verify the labeler is threaded and functioning properly.



Green "Jog" Button: This indicates the labeler can be jogged. Press this button to start a jog process. This button will be grey while the labeler is jogging.



Greyed out "Jog" Button: This indicates the labeler is currently running, and may not be manually jogged.

Labeler Status Indicator:

The status indicator below the Run/Stop buttons will identify which fault state the labeler is in.

Green: Ready / OK. The labeler has no fault conditions and may operate normally.

Yellow: Warning. The labeler has a warning present (typically low on labels). The labeler may operate normally, but will require attention soon.

Red: Faulted. The labeler has a fault on it that will prevent it from dispensing labels.

Grey: Disabled. The labeler is disabled and all functions are bypassed.

Product Count and Reset:

This counter reflects how many Products have passed the product detect sensor while any labeler is Running. The reset button below the counter will set this value to 0.

Label Count and Reset:

This counter reflects how many Labels have been dispensed when Jogging and Running. The reset button below the counter will set this value to 0.

Product Delay:

The Product Delay is used to center the label on the product in the left/right direction. A higher value in the Product Delay parameter will move the label towards the infeed side of the belt. This value is entered as inches.

Label Stop:

Label Stop (in inches) controls the label's stop position. Typically the label should stop with 1/8" to 1/4" sticking off of the peel plate. A higher Label Stop will result in more label off of the peel plate.

Max Feed Length:

The Max Feed Length (in inches) determines how much of the liner will advance when no label division is detected by the Label Sensor. If this value is lower than the physical length of the label, poor label stop will result. This value is typically set to a value at least 1/4" longer than the actual label length. The system also uses this distance to determine if a label is missing on the liner and warning message generation.

Labeler Speed Ratio:

The Labeler Speed Ratio is the value that determines the actual dispensing speed of the labeler.

Encoder Installed: A value of 1.00 means that the labeler will dispense the label at the speed referenced by the encoder signal.

Encoder Disabled: A value of 1.00 means that the labeler will dispense at the speed at which the side belts are set to (from the Main Menu).

The speed ratio can only be changed when the Labeler is stopped.



Labeler Service Menu

The Labeler Service Menu contains parameters and toggles related to the Labeler that are not typically accessed on a regular basis.

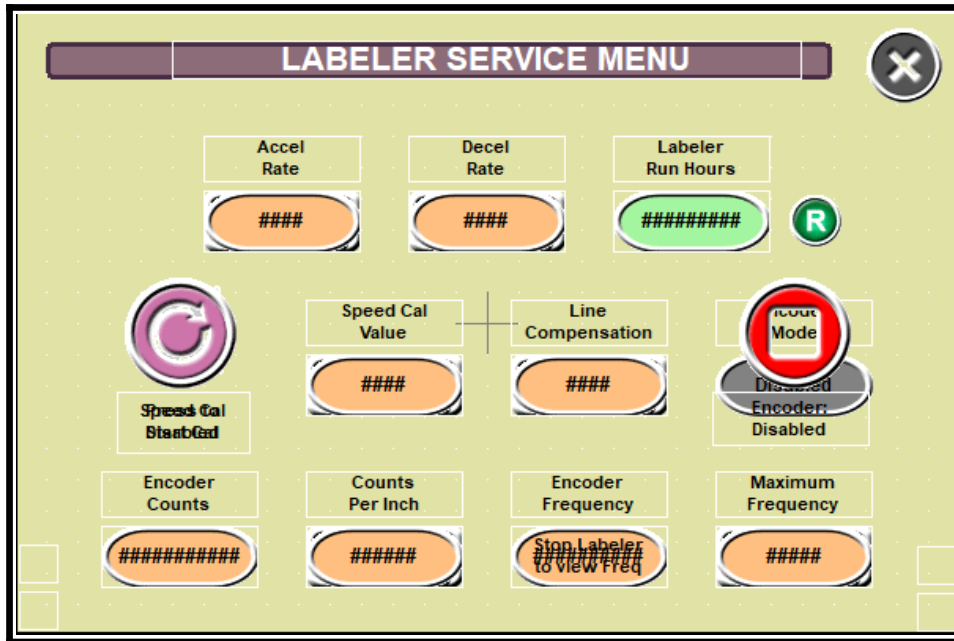

Accel and Decel (Supervisor Level):

These are the ramp values used by the labeler drive when dispensing labels while running. A lower value results in a longer Accel or Decel rate.

Labeler Run Hours:

This counter reflects how many hours the Labeler has been in the Run mode. The green “R” button will reset this value to 0 and is visible when logged in at a Supervisor level.



Calibration: Pressing this button will put the labeler into a Calibration Mode. While active, the labeler's drive system will follow the encoder signal and continue to spin until Calibration Mode is turned off.

Use Caution and make sure the drive and rewind drum are clear before turning the Calibration on!

While the Calibration is active, the Speed Cal value can be changed so the labeler's drive roll speed is equal to that of the master encoder (belt). The Labeler must be Stopped to use the Calibration mode.

Speed Cal (Supervisor Level):

The Speed Calibration number is a factor that allows the labeler to dispense at the belt speed for encoder based systems. This value is calibrated at the factory and should not require further adjustment.

Line Compensation (Supervisor Level):

The Compensation value adds and subtracts product delay based on the master encoder frequency. This allows the labeler to be accurate across all speed ranges. The Compensation value is set at the factory by running products at a slow speed and max speed and then altering the value until the labeler applies the labels in the same location. Note that the Compensation is based off of the Max Frequency value. Changing the Max Frequency will force the need to change the Compensation value.

Encoder Option (Supervisor Level):

The encoder option can be enabled and disabled by using the toggle button.

Green “Enabled”: This indicates the encoder option is enabled. The labeler will use the encoder for Product tracking and speed reference.

Red “Disabled”: This indicates the encoder option is disabled. The labeler will use the set Belt Speed for Product tracking and speed reference.

Encoder Count:

This is the current encoder count as interpreted by the Labeler drive.

Encoder Counts per Inch (Supervisor Level):

The Encoder Counts per Inch value tells the labeler how many encoder pulses are counted for every inch of belt travel. This value is set at the factory and typically does not need adjusted.

Encoder Frequency:

This display will show the encoder frequency value in the labeler drive. Use this to determine the max frequency value. Note that the Labeler must be stopped to view the frequency.

Max Frequency (Supervisor Level):

The Max Frequency is calculated by running the system at max speed and adding 200 to 300 Hz to the displayed Drive Frequency. This is used for line compensation purposes.



System Setup Menu

The System Setup Menu controls the speed of the side belts.

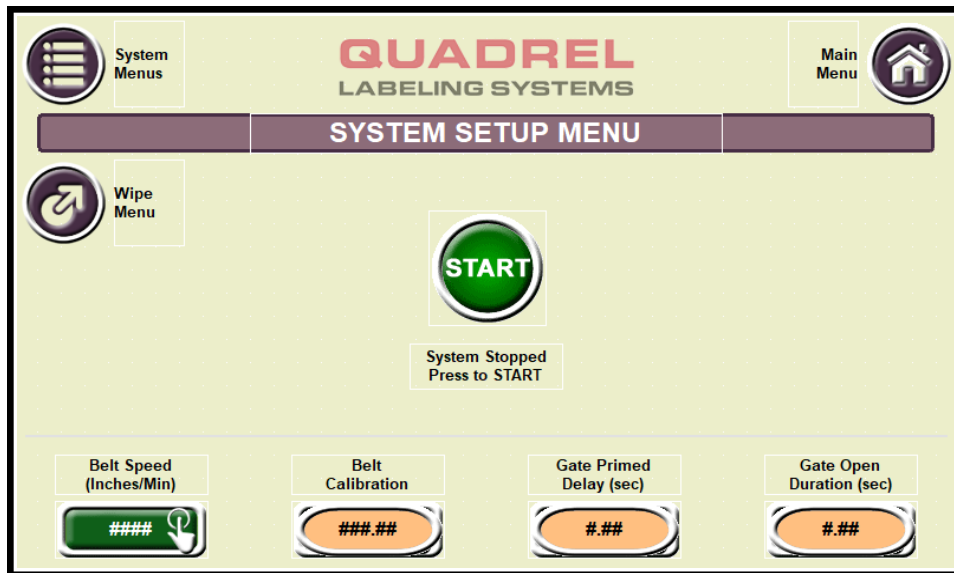

System Run Mode:

The dual side belts can be stopped and started using this button.



Green “Start” Button: Pressing this button will start the system (assuming no fatal faults are present on the system).



Red “Stop” Button: Pressing this button will stop the system.

Belt Speed:

This entry box changes the speed of the dual side belts. It will be entered as inches per minute (100-1600).

Belt Calibration (Supervisor Level):

This calibration parameter allows the side belts to run, in Inches per minute equal to that of the Belt Speed Entry. This is calibrated at the factory and should not require further adjustment.

Gate Primed Delay (Maintenance Level):

This timer will start after the Gate Primed sensor is blocked by a product (and system running). Once the timer expires, the gate cylinder will activate. This timer is entered in seconds.

Gate Duration (Maintenance Level):

When the gate cylinder is activated, it will remain active for this amount of time (in seconds).



Wipe Menu

The System Setup Menu has shortcuts to all of the system menus.

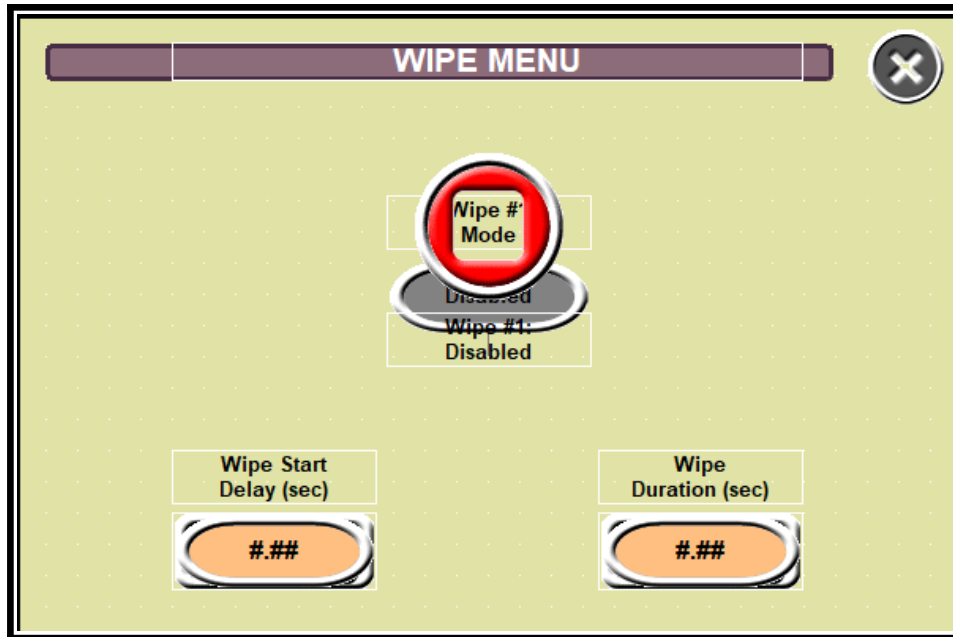

Wipe Enable Button (Supervisor Level):

Green "Enabled": A secondary wipe cylinder will be activated after the labeler dispenses a label (while running).

Red "Disabled": The wipe cylinder will not activate.

Wipe Delay (Maintenance Level):

This timer will start after the labeler dispenses a label. Once the timer expires, the secondary wipe cylinder will activate. This timer is entered in seconds.

Wipe Duration (Maintenance Level):

When the secondary wipe cylinder is activated, it will remain active for this amount of time (in seconds).



User Menu

The User Menu enables alternate login levels to access protected screens and buttons.

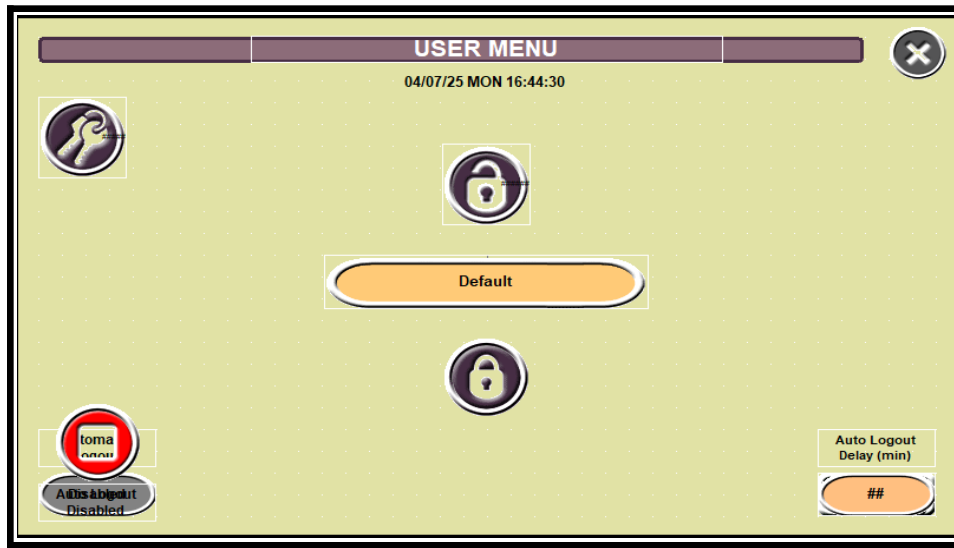

Password Input: Press this button to enter a user password. Passwords are user defined in the Password Manager Menu.



Log Out: Press this button log the current user out.



Password Manager: This will open up a security prompt before opening the password menu, where the passwords for the Maintenance and Supervisor levels are set.

Auto Log Out (Supervisor Level):

When Enabled (button will be Green), the logged in user will automatically be logged off at a set amount of time. Note that the system automatically enables the Auto Log Out feature upon startup.

Log Out Timer (Supervisor Level):

This timer (in minutes) determines the time it takes to log off a user if Auto Log Out is enabled.



Password Menu:

The Password Menu allows the creation and editing of the passwords for different security levels.

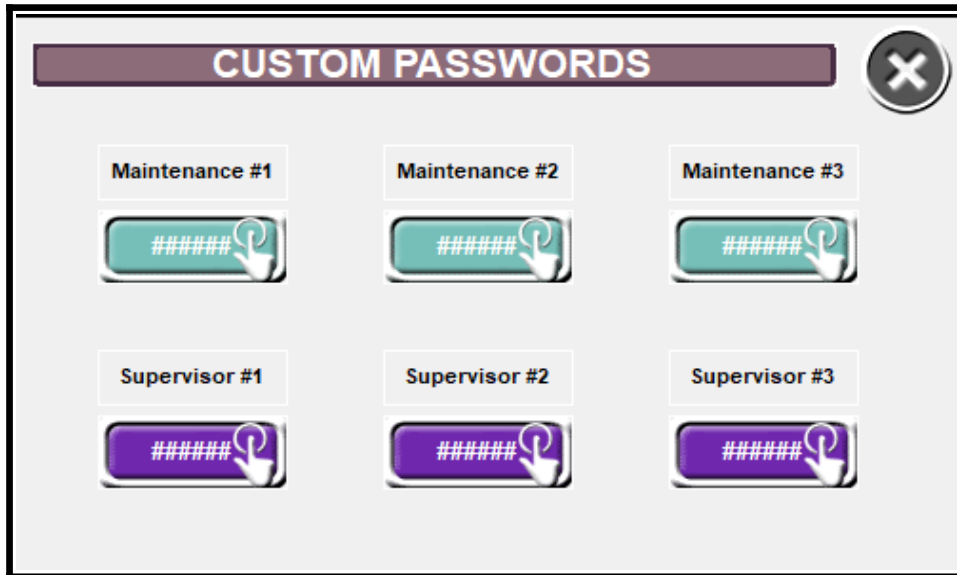

Maintenance:

There can be 3 user defined passwords for the Maintenance level. Note that there is one hard coded Maintenance Level password that cannot be viewed or changed.

Supervisor:

There can be 3 user defined passwords for the Supervisor level. Note that there is one hard coded Supervisor Level password that cannot be viewed or changed.

If a Maintenance and Supervisor password are the same, the system will log that user in at the Maintenance level.

The password(s) to open the Password Menu are stored in the HMI and cannot be modified. This will prevent any password loss in the event the PLC logic is altered.

Fault Messages and Indicators:

Green: Continuous lighted condition indicates the back belt is running when enabled or labeler running when back belt disabled. If a warning is present on the system while lamp is illuminated it will alternate with the amber lamp.

Amber: Indicates the machine has non- major fault affecting operation such as label low level. The Amber lamp will always flash.

Red & Buzzer: The red lamp will flash & buzzer will activate when any fatal fault is present.

Warning Messages: Warning messages identify a status or event that may need action soon. The machine will not stop from a warning message, but a warning may turn into a fatal fault that will stop the machine. Many warning messages will automatically clear once the problem is remedied.

Fatal Messages: Fatal messages will cause the system to stop immediately or initiate a cycle stop. Fatal faults are typically associated to events that prevent labels being applied properly, safety related faults, or other events that may prevent proper machine operation.

Messages	Cause/Solution
Warning Messages	
PLC Power Cycled without Screen #X. Cycle System	The PLC was cycled, but the listed screen was not. When the screen boots up it sends a signal to the PLC to begin executing logic, so the screen or entire system should be cycled in order to function properly.
Labeler #X Drive Faulted Warning	The drive that controls the listed labeler is faulted. If pressing the reset button does not clear this message, cycle the drive power.
Labeler #X Broken Web Warning	The Broken Web sensor (between the drive system and rewind) on the Labeler is active and the Labeler is Stopped. Placing the Labeler into Run will generate a Fatal Fault.
Labeler #X End of Web Warning	The End Of Web sensor (between the drive system and unwind) on the Labeler is active and the Labeler is Stopped. Placing the Labeler into Run will generate a Fatal Fault.
Labeler #X Low Label Supply	The label supply on the labeler has been determined low by the sensor fiber under the flange.
Labeler #X Program Stopped Warning	The internal program of the listed labeler drive is not executing logic. Pressing the Reset button or cycling the safety circuit may re-start the program.
Labeler #X Disabled / Unplugged Warning	The drive is reporting that it is not enabled, which can indicate the I/O cable has become unplugged or a wire disconnected.
Labeler #X Communications Loss Warning	The HMI is reporting that it is not communicating with the listed drive. Verify the drive is powered up and communication cable plugged in.

Messages	Cause/Solution
Fatal Messages	
Emergency Stop Active	An Emergency Stop is active on the system. Depress each Emergency Stop and press Reset from either screen to re-activate the Safety Relay.
DRx Faulted / Turned Off	The listed AC drive is faulted or not powered up
Labeler #X Drive Faulted / Turned Off Fault	The drive that controls the listed labeler is faulted or turned off. If pressing the reset button does not clear this message, verify that the drive is powered up.
Labeler #X Broken Web Fault	The Broken Web sensor (between the drive system and rewind) on the Labeler is active and the Labeler is Stopped. Placing the Labeler into Run will generate a Fatal Fault.
Labeler #X End of Web Fault	The End Of Web sensor (between the drive system and unwind) on the Labeler is active and the Labeler is Stopped. Placing the Labeler into Run will generate a Fatal Fault.
Labeler #X Program Stopped Fault	The internal program of the listed labeler drive is not executing logic. Pressing the Reset button or cycling the safety circuit may re-start the program.
Labeler #X Disabled / Unplugged Fault	The drive is reporting that it is not enabled, which can indicate the I/O cable has become unplugged or a wire disconnected.
Labeler #X Communications Loss Fault	The HMI is reporting that it is not communicating with the listed drive. Verify the drive is powered up and communication cable plugged in.

To set user passwords during initial setup navigate to the passwords screen, then Log in using password "7670" Once logged in users can set passwords per HMI Guide.

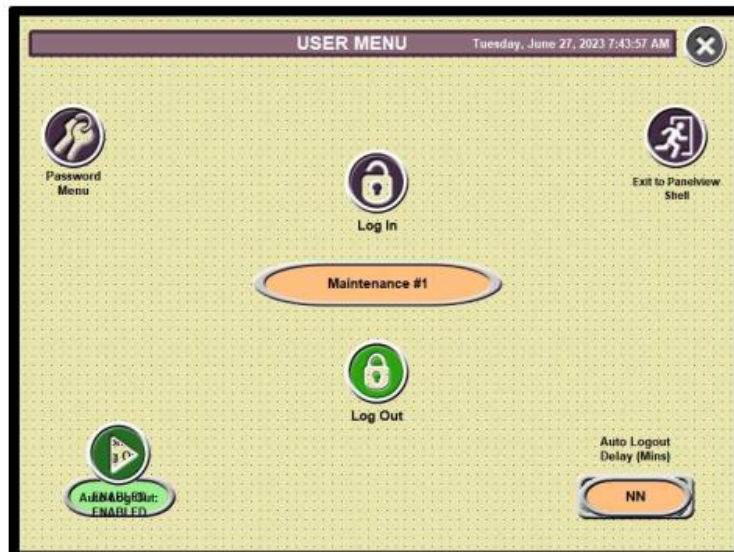
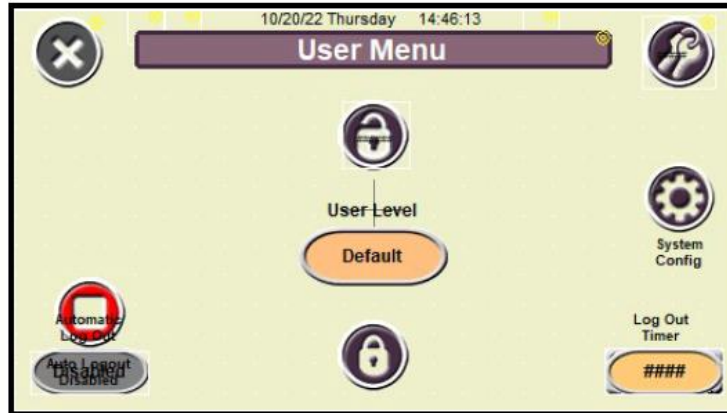

USER MENU 

Sunday mm/dd/yy HH:MM:SS

 Passwords



Current User:
Default



 Log Out
Disabled

Log Out
Timer:
12:34 

Setup sheets

QUADREL

LABELING SYSTEMS

Setup Sheet

SERIAL NUMBER 84263-100
RECIPE # 1

PRODUCT: DOZEN LABEL: 11.63" X 5.38"

LABELER MENU

LABELER 1

Recipe	1
Product Delay	3.45
Label Stop	0.75
Maximum Feed	6.00
Speed Ratio	1.00

LABELER SERVICE MENU

Accel Rate	100
Decel Rate	100
Speed Cal Value	300
Line Compensation	1
Counts Per Inch	1
Maximum Frequency	100
Encoder Mode	Disabled

SECONDARY WIPE MENU

Wipe #1 Enable/Disable	Enabled
Wipe Start Delay	1.35
Wipe Duration	0.40

SYSTEM SETUP MENU

BELT SPEED	500
BELT CALIBRATION	22.80
GATE PRIMED DELAY	0.35
GATE OPEN DURATION	0.75

MECHANICAL ADJUSTMENTS

HUGGER BELTS IN/OUT	1729
LABELER IN/OUT	808

QUADREL

LABELING SYSTEMS

Setup Sheet

SERIAL NUMBER 84263-100

RECIPE # 1

PRODUCT: DOZEN LABEL: 11.63" X 5.38"

LABELER MENU

LABELER 2

Recipe	1
Product Delay	3.45
Label Stop	0.75
Maximum Feed	6.00
Speed Ratio	1.00

LABELER SERVICE MENU

Accel Rate	100
Decel Rate	100
Speed Cal Value	300
Line Compensation	1
Counts Per Inch	1
Maximum Frequency	100
Encoder Mode	Disabled

SECONDARY WIPE MENU

Wipe #1 Enable/Disable	Enabled
Wipe Start Delay	1.35
Wipe Duration	0.40

SYSTEM SETUP MENU

BELT SPEED	500
BELT CALIBRATION	22.80
GATE PRIMED DELAY	0.35
GATE OPEN DURATION	0.75

MECHANICAL ADJUSTMENTS

HUGGER BELTS IN/OUT	1729
LABELER IN/OUT	

QUADREL

LABELING SYSTEMS

Setup Sheet

SERIAL NUMBER 84263-100
RECIPE # 2

PRODUCT: 30 COUNT LABEL: 11.625" X 10.375"

LABELER MENU

LABELER 1

Recipe	2
Product Delay	3.45
Label Stop	0.75
Maximum Feed	6.00
Speed Ratio	1.00

LABELER SERVICE MENU

Accel Rate	100
Decel Rate	100
Speed Cal Value	300
Line Compensation	1
Counts Per Inch	1
Maximum Frequency	100
Encoder Mode	Disabled

SECONDARY WIPE MENU

Wipe #1 Enable/Disable	Enabled
Wipe Start Delay	1.35
Wipe Duration	0.40

SYSTEM SETUP MENU

BELT SPEED	500
BELT CALIBRATION	22.80
GATE PRIMED DELAY	0.35
GATE OPEN DURATION	0.75

MECHANICAL ADJUSTMENTS

HUGGER BELTS IN/OUT	
LABELER IN/OUT	

QUADREL

LABELING SYSTEMS

Setup Sheet

SERIAL NUMBER 84263-100
RECIPE # 2

PRODUCT: 30 COUNT LABEL: 11.625" X 10.375"

LABELER MENU

LABELER 2

Recipe	2
Product Delay	3.45
Label Stop	0.75
Maximum Feed	6.00
Speed Ratio	1.00

LABELER SERVICE MENU

Accel Rate	100
Decel Rate	100
Speed Cal Value	300
Line Compensation	1
Counts Per Inch	1
Maximum Frequency	100
Encoder Mode	Disabled

SECONDARY WIPE MENU

Wipe #1 Enable/Disable	Enabled
Wipe Start Delay	1.35
Wipe Duration	0.40

SYSTEM SETUP MENU

BELT SPEED	500
BELT CALIBRATION	22.80
GATE PRIMED DELAY	0.35
GATE OPEN DURATION	0.75

MECHANICAL ADJUSTMENTS

HUGGER BELTS IN/OUT	
LABELER IN/OUT	

QUADREL

LABELING SYSTEMS

Setup Sheet

SERIAL NUMBER 84263-100

RECIPE #

PRODUCT: LABEL:

LABELER MENU

LABELER 1

Recipe	
Product Delay	
Label Stop	
Maximum Feed	
Speed Ratio	

LABELER SERVICE MENU

Accel Rate	
Decel Rate	
Speed Cal Value	
Line Compensation	
Counts Per Inch	
Maximum Frequency	
Encoder Mode	

SECONDARY WIPE MENU

Wipe #1 Enable/Disable	
Wipe Start Delay	
Wipe Duration	

SYSTEM SETUP MENU

BELT SPEED	
BELT CALIBRATION	
GATE PRIMED DELAY	
GATE OPEN DURATION	

MECHANICAL ADJUSTMENTS

HUGGER BELTS IN/OUT	
LABELER IN/OUT	

QUADREL

LABELING SYSTEMS

Setup Sheet

SERIAL NUMBER 84263-100

RECIPE #

PRODUCT: LABEL:

LABELER MENU

LABELER 2

Recipe	
Product Delay	
Label Stop	
Maximum Feed	
Speed Ratio	

LABELER SERVICE MENU

Accel Rate	
Decel Rate	
Speed Cal Value	
Line Compensation	
Counts Per Inch	
Maximum Frequency	
Encoder Mode	

SECONDARY WIPE MENU

Wipe #1 Enable/Disable	
Wipe Start Delay	
Wipe Duration	

SYSTEM SETUP MENU

BELT SPEED	
BELT CALIBRATION	
GATE PRIMED DELAY	
GATE OPEN DURATION	

MECHANICAL ADJUSTMENTS

HUGGER BELTS IN/OUT	
LABELER IN/OUT	

Fuji Frenic Mini v.012

For use with Techlines with Keyence Nano PLC & Weintek/Maple HMI

Job: 84263 Drive: DR2 Motor: Huyser #2 (2 x 0.38HP motors)

SETUP AND ADJUSTMENTS: (Reference Fuji drive manual for detailed information)

Set Primary Parameters:

Parameter	Fuji Default	Quadrel Default Value	Quadrel Final Value	Description
F01	4	0 (Keypad)	1 ✓	Freq. Command
F02	2	1 (Terminals)	1 ✓	Operation
F03*	60.0	60.0	90.00	Max Frequency
F07	6.0	3.0	3.0	Accel Time
F08	6.0	3.0	3.0	Decel Time
F15	70	70	90.00	Frequency Limit
F42	0	2	2 ✓	Control Mode
H30**	0	1	1 ✓	Comm Function
E27	99	0	0 ✓	Relay Function
P99	0	1 (HP)	1 ✓	Motor Type
P02	Varies	See Motor Nameplate	0.76	Rated Capacity (HP)
Y01***	1	1	1 (Conveyor Only) ✓	Drive Address
Y10	1	0	0 ✓	Protocol

*: If F03 needs to be greater than 70.0 (F15 Default), F15 must be changed first.

**: 1 for Conveyor, Feedscrew, or Three Roller Wrap. 0 for all others.

***: 1 for Conveyor, 2 for Three Roller Wrap, 3 for Feedscrew

P02 Reference for frequently used motors:

3/8 HP: 0.38, 1/6 HP: 0.17

Initialize Parameters

- Navigate to Parameter H03
- Use the STOP and UP Arrow to change H03 to "2". Press the Func/Data button.
- "Save" will flash on the display. H03 will revert back to "0" once the parameters are automatically set.

Set the Motor Current based on the Motor Nameplate value. Entered as Amps.

Parameter	Fuji Default	Motor Nameplate	Quadrel Final value
P03	Varies	4.00	4.00

P03 Reference for frequently used motors:

2x → 3/8 HP: 1.9, 1/6 HP: 0.73

S03 Jumper Setting:

Default is in the OFF position.

Standard Systems: Set DR1 Conveyor to ON position. Other drives set to default/OFF.

Three Roller Systems: Set Wrap drive to ON position. Other drives set to default/OFF.

Feedscrew systems: Set Feedscrew drive to ON position. Other drives set to default/OFF.

SINK/SOURCE Jumper Setting: SOURCE (All Drives)

N/A

~~When Chain Aligners Installed, F30 (Analog Out Adjustment) on DR2 will change the Chain Aligner Speed~~

Parameter	Fuji Default	Quadrel Default Value	Quadrel Final value
F30	100	200	

Fuji Frenic Mini v.012

For use with Techlines with Keyence Nano PLC & Weintek/Maple HMI

Job: 84263 Drive: DR1 Motor: Hussers #1 (2x 0.38HP motors)

SETUP AND ADJUSTMENTS: (Reference Fuji drive manual for detailed information)

Set Primary Parameters:

Parameter	Fuji Default	Quadrel Default Value	Quadrel Final Value	Description
F01	4	0 (Keypad)	1 ✓	Freq. Command
F02	2	1 (Terminals)	1 ✓	Operation
F03*	60.0	60.0	90.00	Max Frequency
F07	6.0	3.0	3.0	Accel Time
F08	6.0	3.0	3.0	Decel Time
F15	70	70	90.00	Frequency Limit
F42	0	2	2 ✓	Control Mode
H30**	0	1	1 ✓	Comm Function
E27	99	0	0 ✓	Relay Function
P99	0	1 (HP)	1 ✓	Motor Type
P02	Varies	See Motor Nameplate	0.76	Rated Capacity (HP)
Y01***	1	1	1 (Conveyor Only) ✓	Drive Address
Y10	1	0	0 ✓	Protocol

*: If F03 needs to be greater than 70.0 (F15 Default), F15 must be changed first.

**: 1 for Conveyor, Feedscrew, or Three Roller Wrap. 0 for all others.

***: 1 for Conveyor, 2 for Three Roller Wrap, 3 for Feedscrew

P02 Reference for frequently used motors:

3/8 HP: 0.38, 1/6 HP: 0.17

Initialize Parameters

- Navigate to Parameter H03
- Use the STOP and UP Arrow to change H03 to "2". Press the Func/Data button.
- "Save" will flash on the display. H03 will revert back to "0" once the parameters are automatically set.

Set the Motor Current based on the Motor Nameplate value. Entered as Amps.

Parameter	Fuji Default	Motor Nameplate	Quadrel Final value
P03	Varies	4.00	4.00

P03 Reference for frequently used motors:

2x → 3/8 HP: 1.9, 1/6 HP: 0.73

S03 Jumper Setting:

Default is in the OFF position.

Standard Systems: Set DR1 Conveyor to ON position. Other drives set to default/OFF.

Three Roller Systems: Set Wrap drive to ON position. Other drives set to default/OFF.

Feedscrew systems: Set Feedscrew drive to ON position. Other drives set to default/OFF.

SINK/SOURCE Jumper Setting: SOURCE (All Drives)

~~When Chain Aligners Installed, F30 (Analog Out Adjustment) on DR2 will change the Chain Aligner Speed~~

Parameter	Fuji Default	Quadrel Default Value	Quadrel Final value
F30	100	200	100

N/A

WARNING



! WARNING

1. READ AND UNDERSTAND THE OPERATION MANUAL AND ALL SAFETY LABELS BEFORE OPERATING THIS MACHINE.
2. ONLY A TRAINED PERSON IS TO BE PERMITTED TO OPERATE THIS MACHINE. TRAINING SHOULD INCLUDE INSTRUCTION IN OPERATION UNDER NORMAL CONDITIONS AND EMERGENCY SITUATIONS.
3. THIS MACHINE IS TO BE SERVICED ONLY BY TRAINED AND AUTHORIZED PERSONNEL. FOLLOW LOCK-OUT PROCEDURES BEFORE SERVICING.
4. NEVER REACH INTO THE MACHINE FOR ANY REASON UNLESS THE MACHINE IS AT A COMPLETE STOP.
5. NEVER LEAVE THE MACHINE STOPPED IN SUCH A MANNER THAT ANOTHER WORKER CAN START THE MACHINE WHILE YOU ARE WORKING ON OR WITHIN THE MACHINE.
6. NEVER CHANGE OR DEFEAT THE FUNCTION OF ELECTRICAL INTERLOCKS OR OTHER MACHINE "SHUTDOWN" SWITCHES.
7. BEFORE STARTING THIS MACHINE, CHECK THAT: ALL PERSONS ARE CLEAR OF THE MACHINE; NO MAINTENANCE WORK IS BEING PERFORMED ON THE MACHINE, ALL GUARDS ARE IN PLACE.
8. ROUTINE INSPECTIONS AND CORRECTIVE/PREVENTATIVE MAINTENANCE MEASURES ARE TO BE CONDUCTED TO ENSURE THAT ALL GUARDS AND SAFETY FEATURES ARE RETAINED AND FUNCTION PROPERLY.

- KEEP HAND CLEAR OF MOVING PARTS. DO NOT PLACE HANDS NEAR LABELING HEAD WHEN IN OPERATION



- DO NOT OPERATE EQUIPMENT WITHOUT GUARDS OR COVERS INSTALLED



6.1 LABELING HEAD INFORMATION

6.1.1 LOADING AND UNLOADING STOCK ROLL

-  **CAUTION** To avoid injuries, you must keep the labeler stopped/paused. You can manually jog labels with the JOG button.

Look carefully at the diagram and follow the threading procedures indicated below.

You will also find the threading diagram directly on the labeling head.

- 1) Place the label stock roll on the unwind shaft. Press the roll firmly against the flange. Then slide the locking collar over the unwind shaft aligning the set screw with the shaft. Press into the roll and twist to lock the collar in place.



- 2) Pull Approximately 36-40" of stock from label stock roll.



- 3) Follow the threading diagram on the labeling head for routing the web.
- 4) Thread through the dancer to the peel plate.





- 5) Feed the label around the peel plate and under the pressure shoe if (if there is one). Feed the label up the head to the pull roll. Pull all the slack out.

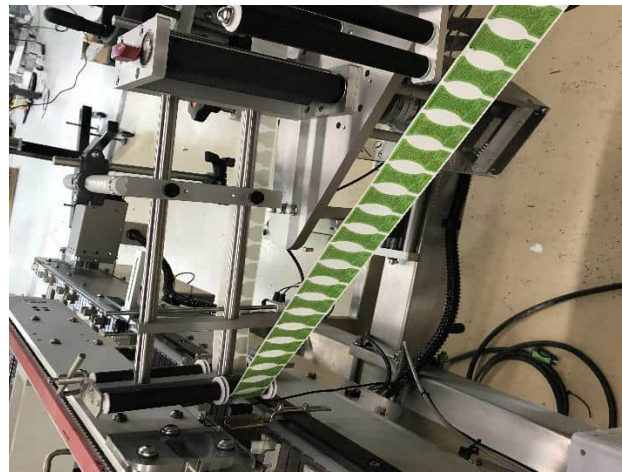
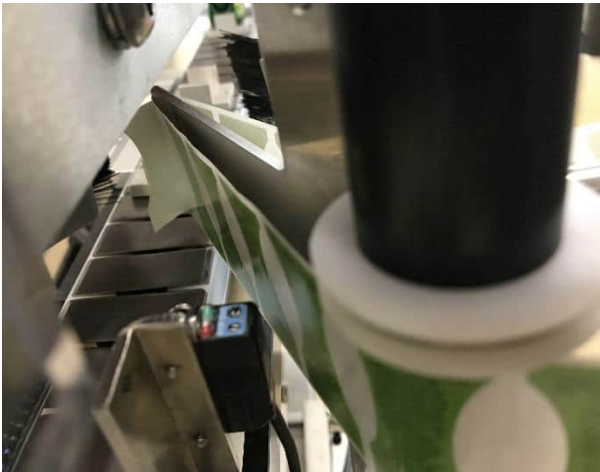

- 6) Wrap labels around the rubber roller as shown, then around the knurled roller. Make sure the knurled roller is not locked in by turning the red knob to the left or right of the red dot on the drive roll. When you have the labels completely threaded you can turn the knob to the red dot.

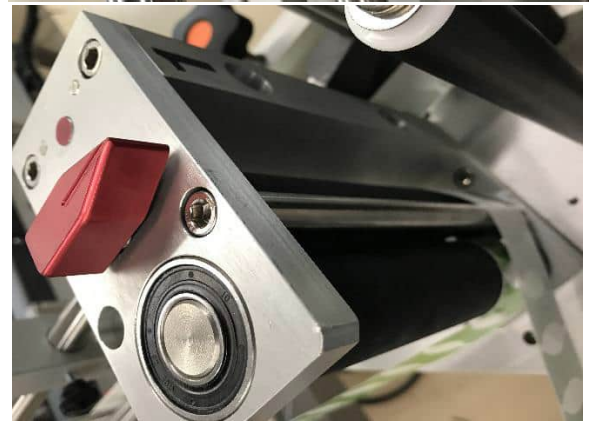
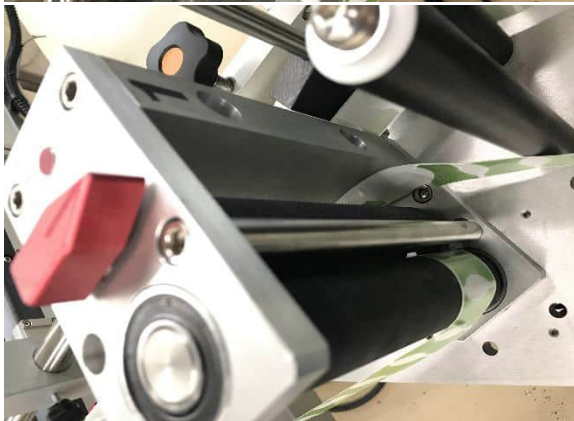
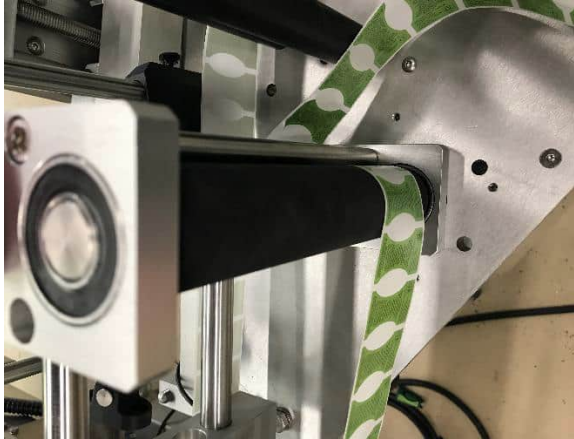

- 7) Thread the labels through the rewind dancers to the rewind shaft. Place the end of the label through the clip and rotate the rewind hub to take up the slack.



- 8) The finished product should look similar to the pictures below. Some heads are threaded differently depending on the style head you have. See threading diagrams on the head itself or the manual.

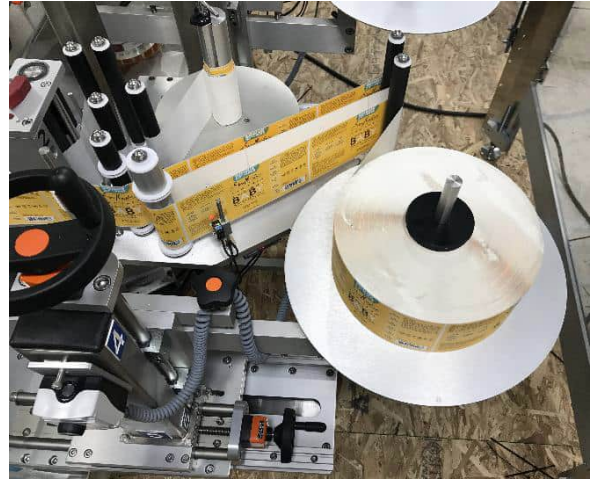

- 9) To unload the rewind loosen (counter clockwise) the “clevis” bolt on the top of the rewind hub. this will collapse the rewind and you can pull the liner off the hub.



CAUTION

There are many pinch points on a labeler. to avoid injury read and understand the owner’s manual before operating.

6.1.2 THREADING DIAGRAMS

Here are the following threading diagrams for our standard labeling heads.

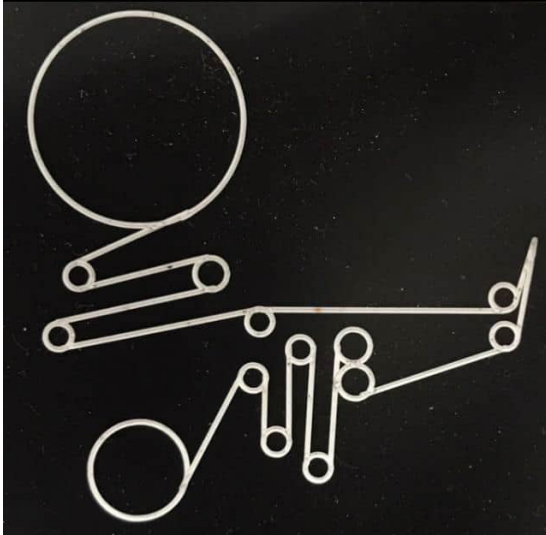

Q120/Q125/Q115/Q110

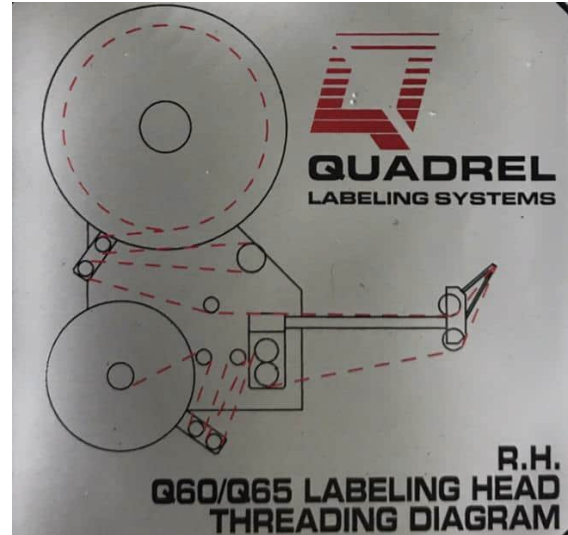

Q60/Q65

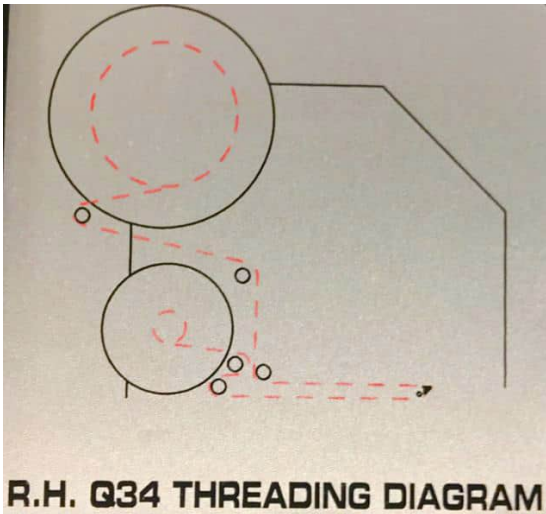

Q34

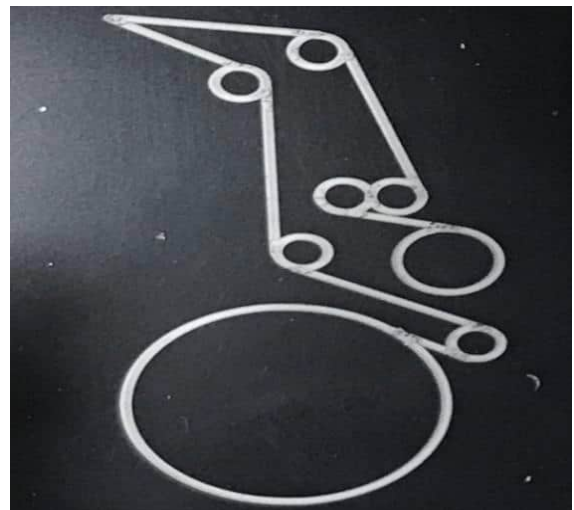

E100

6.1.3 LABELER ADJUSTMENTS

The vertical adjustment is to position the label on the container at different heights. It's practical if you have different size labels and/or containers. To adjust the height you simply rotate the handwheel at the top of the labeler counter clockwise to go down and clockwise to go up.



Horizontal adjustments are made the same way except you rotate the hand wheel under the labeler. Rotating the hand wheel counter clockwise will move the labeler in and rotating clockwise will move the labeler out.



To adjust the angle of the labeling head you first need to loosen the large $\frac{3}{4}$ -10 nut with a $1\frac{1}{4}$ " wrench and the $\frac{5}{16}$ -18 hex head bolt. The angular adjustment is very important to increase the repeatability of the process. A good adjustment is when the exit of the label is tangent with the surface of the application.



CAUTION

DO NOT remove the nut & bolt.



Now to adjust the tilt of the labeling head by tightening and loosening the jack screws.



Rotate adjustment is achieved by loosening the 2 ratchet handles under the labeling head. There is a jack screw holding the labeling head in place, but still use caution when loosening the ratchet handles the labeling head can rotate

freely when loose. This is a fine adjustment that increases the parallelism of the label to the shape of the container.



CAUTION

When loosening the labeling head, the head may rotate freely. Keep positive pressure against the head to prevent the head from rotating on its own.





QUADREL LABELING SYSTEMS

Q60 7" LABELING HEAD

GENERAL DESCRIPTION

- The Q60 has been developed as a heavy duty automatic labeling head system for integration into high speed, high rate production environments. The labeling head can be configured for either wrap or wipe on applications. The Q60 labeler features a PLC based control, insuring accurate and drift free label application. The Q60 uses a high-torque stepping motor for web drive. The step motor drive system is indexed directly from the PLC controller. This allows for precise adjustment and calibration for any number of applications. In addition, a built in system of fault logic can easily interface with a host of optional sensors.

PRINCIPLE OF FUNCTION

- The Q60 labeling head applies pressure sensitive labels onto moving products. Various principles are involved to achieve accurate label application. In general, a labeling system integrates three (3) basic functions:
 - **Product Handling:** The most common product handling component is the conveyor. Conveyors allow the product to transport smoothly through the labeling station. The Q60 labeler can be supplied either as a stand alone head (head on a stand) or integrated into a complete conveying/product handling system.
 - **Label Application:** Usually the label is "tacked" directly to the product during the label dispensing cycle. Secondary label applicators such as brushes, roller or wrap belts are used to finish the label application and to ensure good adhesion.
 - **Label Dispensing:** The labeling head uses a DC step motor to dispense the label. The label dispensing cycle begins when a product is sensed by the product sensor. This signal engages the drive motor which advances the unwind, and dispenses a label. As the label is dispensed, a slot sensor detects the division between the labels and disengages the motor. The DC step motor uses an internal braking action which holds the motor in a locked position preventing web movement between application cycles. All delays, sequencing and indexing are controlled by the PLC.

SEQUENCE OF OPERATION:

- The electrical and mechanical operating sequence described below is intended only to acquaint the operator with the operation of the label dispensing head and its related control circuitry.
- The "Jog Key" is provided for manual set-up of label dispensing. When it is depressed a single label dispense cycle is initiated.
- The label dispensing cycle is described in the following manner:
 1. The labeling cycle is initiated by the detection of a product by the product detect sensor. This triggers the start of the PRODUCT DELAY cycle which is indicated by the PRODUCT DETECT control panel LED.
 2. Label position time is initiated. The duration of the delay is set by the PRODUCT DELAY preset.
 3. At the end of this preset delay period, the label dispensing motor is energized. Label dispensing "starts."
 4. The label division (space between labels) passes through the label sensor gap and initiates the LABEL DELAY time-out. (Also considered label FLAG) As the label division is sensed by the label sensor, the red front panel LABEL DETECT LED will indicate the LABEL DELAY time-out.
 5. Label stop (flag) time is initiated.
 6. At the end of a preset time period, the label dispensing motor is de-energized and the label feed stops.
 7. If the optional imprinter is installed, the imprint cycle commences. At the completion of this cycle, the system is reset.

ASSEMBLY TITLE: Q60 LABELING HEAD ASSEMBLY

DRAWING NO.: None Applicable

GENERAL FUNCTION:

- Applies labels to the front and/or back, top/bottom of the products
- Wraps labels around cylindrical products

SET-UP AND ADJUSTMENTS:

- Tighten all loose connections and screws
- As noted in each sub-assembly

MAINTENANCE:

- Remove glue residue and labels from all rollers and idlers
- As noted in each sub-assembly

TROUBLESHOOTING:

- As noted in each sub-assembly

Options:

- 4-1/2" and 7" Wide Web Versions
- Hot Stamp Imprinter
- Missing Imprint Detection
- Low Label Detection
- End of Web Detection
- Missing Label on Web Detection
- Broken Web Detection
- Support Stand
- Recommended Spare Parts Kit

ASSEMBLY TITLE: Q60 LABELING HEAD - DANCER ARM ASSEMBLY

DRAWING NO.: None Applicable

GENERAL FUNCTION:

- The dancer arm and braking mechanism are used to control the unwind unit which will only advance a few inches of web at any time
- The position of the dancer arm affects the advancement of the web off the label roll.

SET UP AND ADJUSTMENTS:

- The dancer normal position of the dancer arm is reached when the dancer arm locks the supply reel.
- The spring tension can be adjusted to correctly locate the dance arm
- The spring may be adjusted by turning the threaded tensioner located near the unwind unit.
- The spring should be tight enough to bring the dancer arm back to its normal position and hold it with some force, but not tight enough to tear the web during label feed.
- Spring adjustment is also possible by rotating the spring mounting pin on the spring take up pulley around the mounting shaft.
- While in its normal position, the dancer arm roller should not interfere with the supply reel flange.

MAINTENANCE:

- Replace dancer spring if final spring tension is too soft.

TROUBLESHOOTING:

PROBLEM

- Web break
- Too much web slack
- Dancer arm hits supply flange position by loosening the brake cam.

WHAT TO DO

- Lower spring tension on dancer arm
- Increase spring tension
- Correct dancer arm final

ASSEMBLY TITLE: Q60 LABELING HEAD - BRAKE BRUSH ASSEMBLY

DRAWING NO.: None Applicable

GENERAL FUNCTION:

- The brake brush establishes web tension and controls backlash

SET UP AND ADJUSTMENTS:

- For accurate label feeds, the web must establish proper tension.
- Loosen the holding set screw in the brake brush body. The brake brush assembly can now be rotated on axis.
- Turn brush body into the web and tighten. To check for proper web tension, jog a label and check for web slack. If the web is tight and the label feeds correctly, the brush tension is set correctly.
- If backlash persists, continue to increase brake brush tension.

MAINTENANCE:

- Replace brake brush when brush body contour no longer viable or bristles are worn down.

TROUBLESHOOTING:

PROBLEM

- Web break
- Motor stall
- Too much web slack

WHAT TO DO

- Too much brake tension. Decrease until no slack in web.
- Debris or brake flaw causing web tear
- Decrease brake tension
- Increase brake tension

ASSEMBLY TITLE: Q60 LABELING HEAD - THREADING

**DRAWING NO: A24975-000 (Right Hand)
A24976-000 (Left Hand)**

GENERAL FUNCTION:

- This section is used to guide the user through loading and feeding the label through the web path.

SET UP AND ADJUSTMENTS:

- Load label spool onto unwind hub. Secure unwind retainer onto hub and lock. Pull 3-4 feet of web from unwind and strip labels free of web.
- Unlock the drive roller locking handle.
- Using the threading diagram located on the labeling head, feed the web through the labeling head. Start at the unwind dancer assembly and work forward.
- Feed the web through the drive roller assembly.
- Feed the web around the rewind dancer assembly and onto the rewind hub. Wrap the web around the hub once. Lock the web in place with the rewind retaining bracket.
- Once the web has been threaded, lock down the drive roll assembly by rotating the drive roll locking arm into the locked position. (Towards the drive roller assembly)

MAINTENANCE:

- None this section.

TROUBLESHOOTING:

PROBLEM

WHAT TO DO

- | | |
|--|--|
| <ul style="list-style-type: none">- Web break- No Web Tension | <ul style="list-style-type: none">- Check web path and insure web routed correctly.- Debris causing web tear and break. Clear as needed.- Check web path through unwind and dancer assembly.- Check drive roller lock position. |
|--|--|

NOTES :

- 1) LABEL MATERIAL IS .003" ALUMINUM FOIL W/PERMANENT PRESSURE SENSITIVE ADHESIVE.
- 2) ALL LETTERING IS .125" HIGH EUROSTYLE 2, BOLD EXTENDED 2.
- 3) USE QUADREL STANDARD LOGO.
- 4) ALL LINES AND LETTERS ARE BLACK ON A SILVER BACKGROUND (WEB PATH) HAS RED DASHED LINES.
- 5) LABEL SIZE 3.0" X 3.0" .

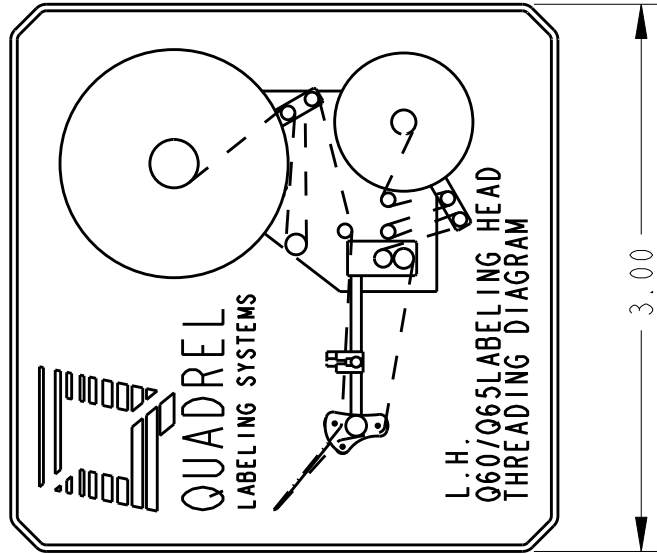

A	10/14/2011	NEW DRAWING
REV	DATE	DESCRIPTION

THIS IS A PRO-ENGINEER DOCUMENT AND MAY NOT BE MODIFIED MANUALLY	
UNLESS OTHERWISE SPECIFIED DIMENSIONAL TOLERANCE X ± .1 XX ± .01 XXX ± .005 ANGLES ± 30'	QUADREL LABELING SYSTEMS 7670 JENTHER DRIVE MENTOR, OHIO 44060 (440) 602-4700
SCALE: DRAWING SCALE DATE: 10/14/2011 DRW BY: SEM CHK BY: APPR BY:	Q60/Q65 L.H. THREADING DIAGRAM
SURFACE FINISH .125 BREAK ALL EDGES .005/.015 CORNER RADIUS .010/.030	MAT'L SEE NOTES
	A25749-000

ASSEMBLY TITLE: Q60 SIDE PLATE ASSEMBLY

DRAWING NO.: 7" Web D22518-000

GENERAL FUNCTION:

- To provide a rigid mounting surface for outboard labeling components, labeling components, electronic components, and system components.
- The side plate also supports the system mount

SET UP AND ADJUSTMENTS:

- None

MAINTENANCE:

- None

TROUBLESHOOTING:

- None

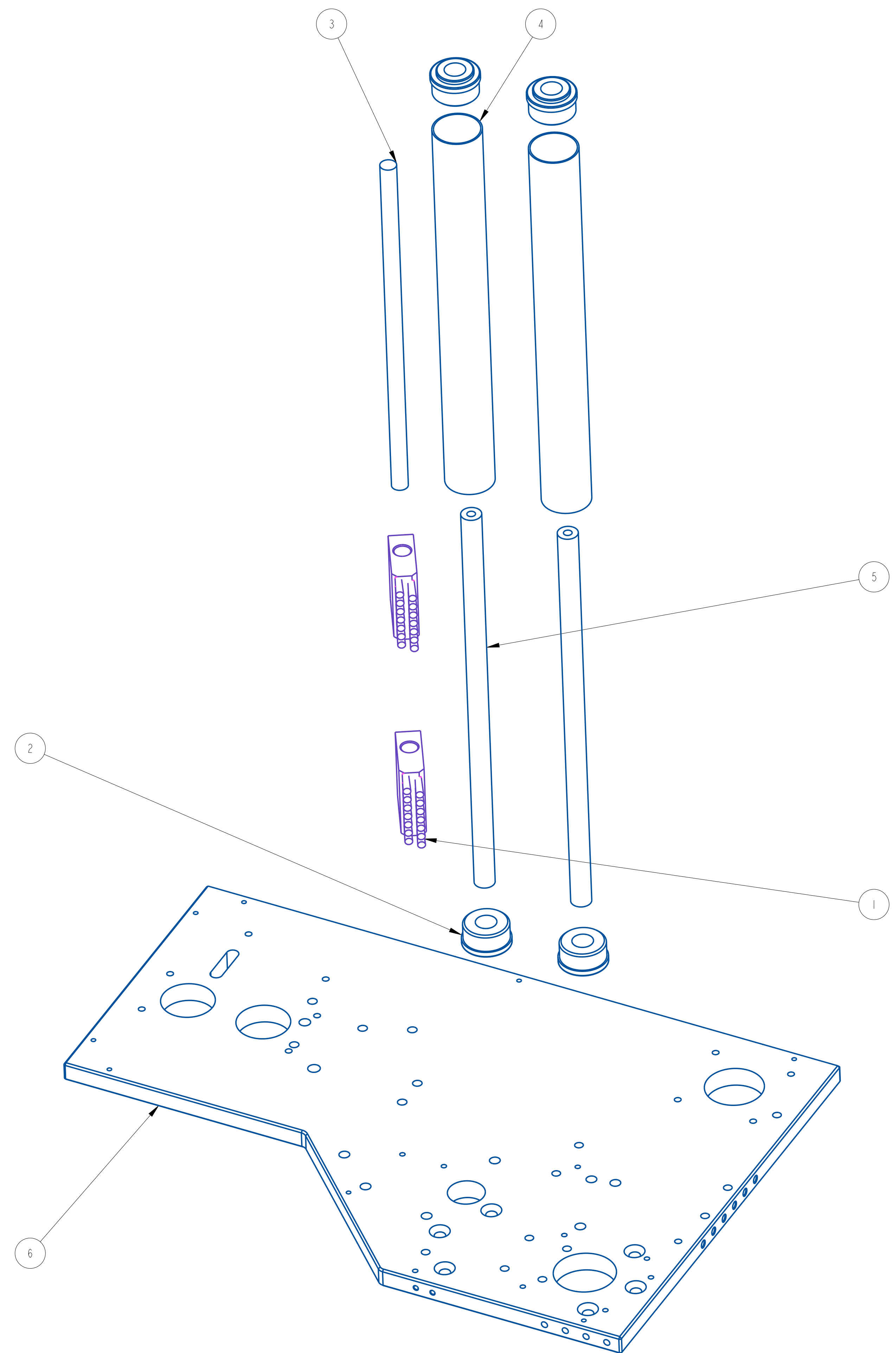

ITEM	QTY	PART NO.	DESCRIPTION	PARENT ITEM
1	2	00669-01	BRAKE BRUSH 2 x 7 nylon	21753A-004
2	4	181062-000	BEARING, ROLL END	21753A-004
3	1	A20654-001	ADJ. ROD	21753A-004
4	2	A21259-113	IDLER ROLLER	21753A-004
5	2	A21618-013	IDLER SHAFT	21753A-004
6	1	D23842-005	Q60 SIDE PLATE LH MOD.	21753A-004

REV	DATE	DESCRIPTION	BY
A	Mar-06-25	NEW DRAWING	TAZ

THIS IS A PRO-ENGINEER DOCUMENT AND MAY NOT BE MODIFIED MANUALLY

UNLESS OTHERWISE SPECIFIED
 DIMENSIONAL TOLERANCE
 .x ± .1
 .xx ± .01
 .xxx ± .005
 ANGLES ± .30°
 SURFACE FINISH 125
 BREAK ALL EDGES .005/ .015
 CORNER RADIUS .010/ .030
 ALL ANGLES ARE 90°

QUADREL LABELING SYSTEMS
 7670 JENTHER DRIVE
 MENTOR, OHIO 44060
 (440) 602-4700

SCALE: 1/2
 DATE: Mar-06-25
 DRW BY: TAZ
 CHK BY:
 APPR BY:

MAT'L	QTY	PART NO.	DESCRIPTION	PARENT ITEM
			Q60 12" SIDE PLATE	
		21753A-004		21753A-004

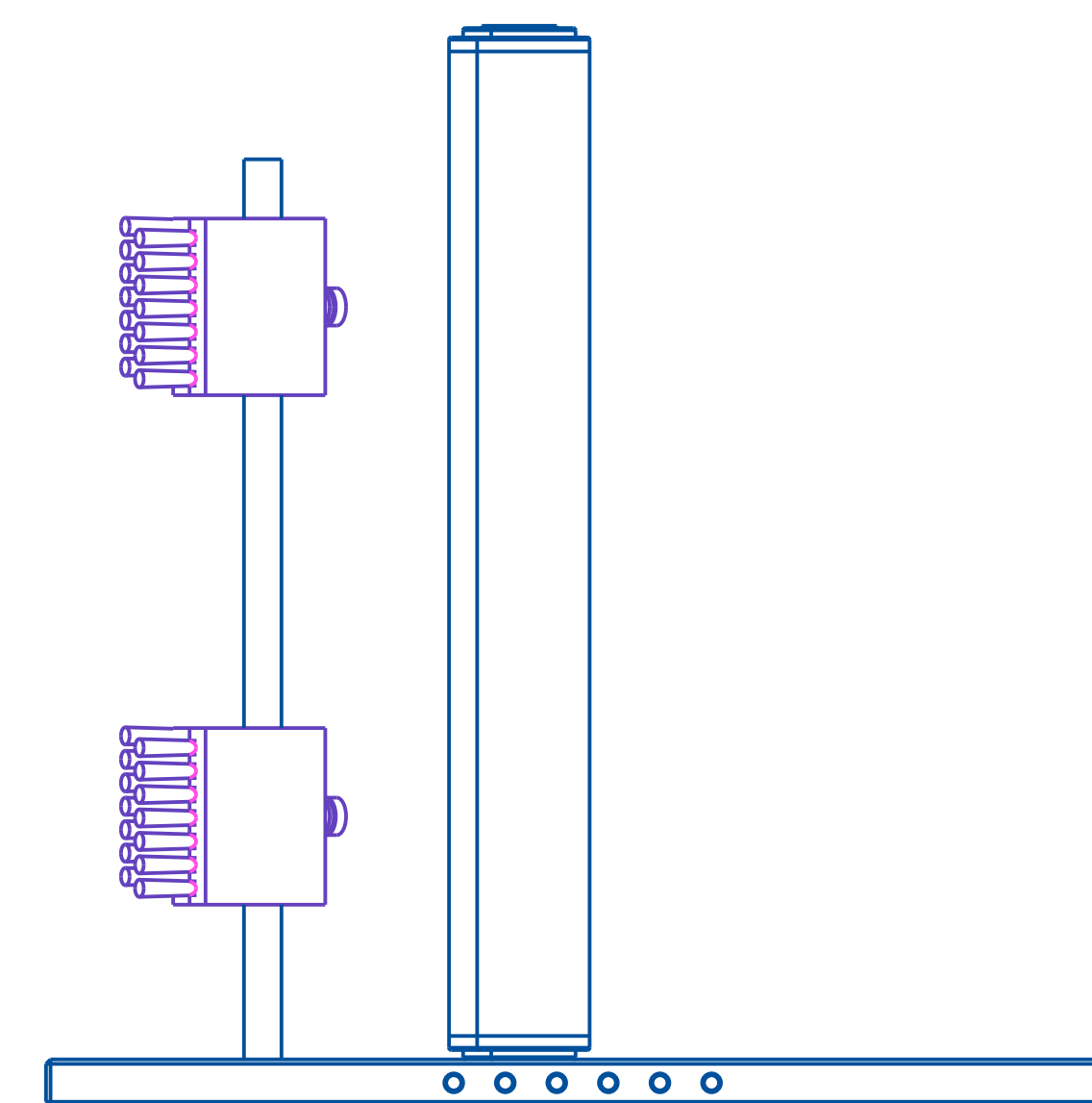
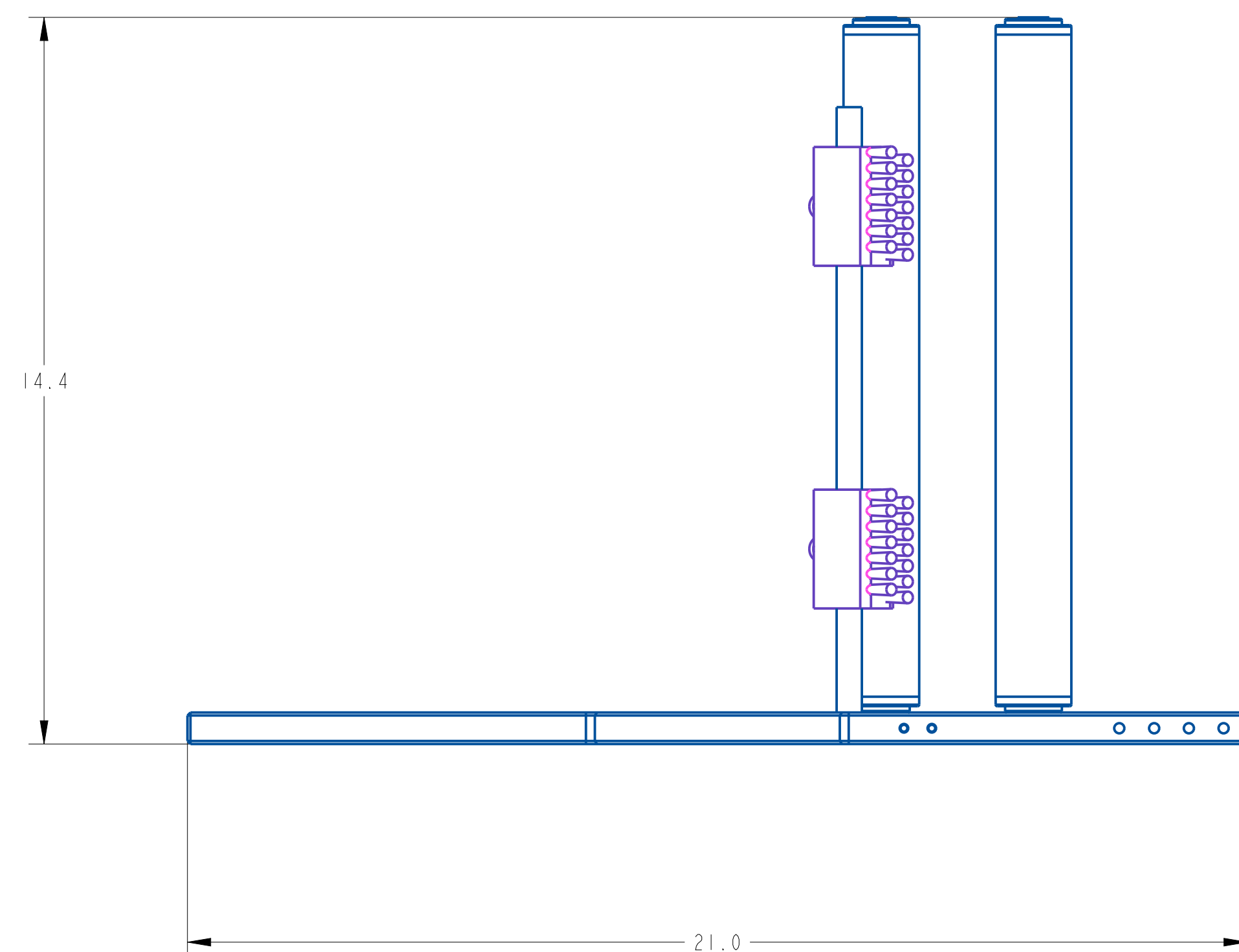
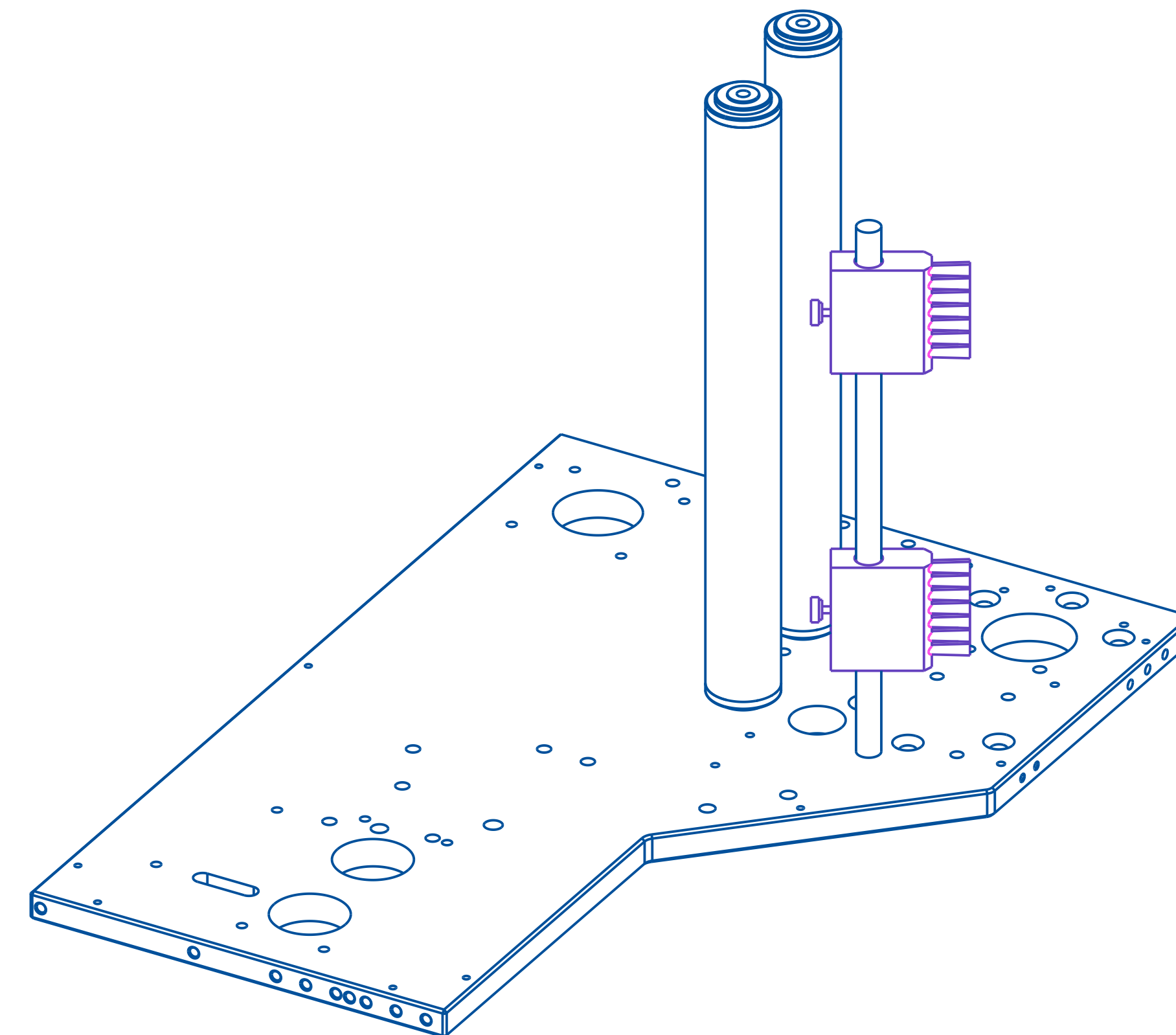
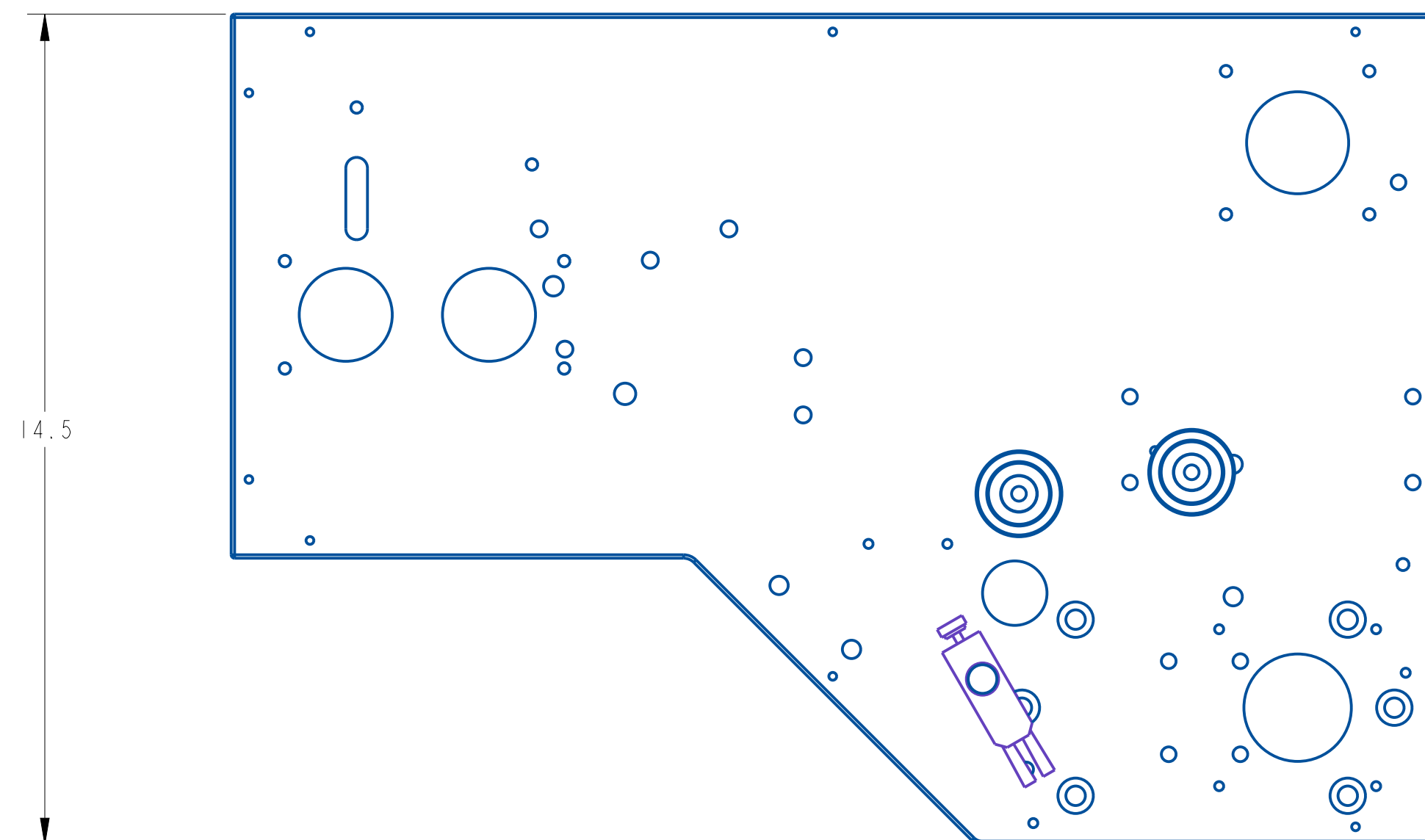

SHEET 2 OF 2

THIS IS A PRO-ENGINEER DOCUMENT AND MAY NOT BE MODIFIED MANUALLY

UNLESS OTHERWISE SPECIFIED	QUADREL LABELING SYSTEMS	SCALE:	13/32
DIMENSIONAL TOLERANCE	7670 JENTHER DRIVE	DATE:	Mar-06-25
x ± .1	MENTOR, OHIO 44060	DRW BY:	TAZ
xx ± .01	(440) 602-4700	CHK BY:	
xxx ± .005		APPR BY:	
ANGLES ± .30°			
SURFACE FINISH 125			
BREAK ALL EDGES .005/0.15			
CORNER RADIUS .010/0.30			
ALL ANGLES ARE 90°			

A	Mar-06-25	NEW DRAWING	TAZ
REV	DATE	DESCRIPTION	BY

Q60 12" SIDE PLATE

MAT'L	21753A-004	21753A-004
-------	------------	------------

ITEM	QTY	PART NO.	DESCRIPTION	PARENT ITEM
1	2	00669-01	BRAKE BRUSH 2 x 7 nylon	21753A-005
2	4	181062-000	BEARING, ROLL END	21753A-005
3	1	A20654-001	ADJ. ROD	21753A-005
4	2	A21259-113	IDLER ROLLER	21753A-005
5	2	A21618-013	IDLER SHAFT	21753A-005
6	1	D23842-006	Q60 SIDE PLATE LH MOD.	21753A-005

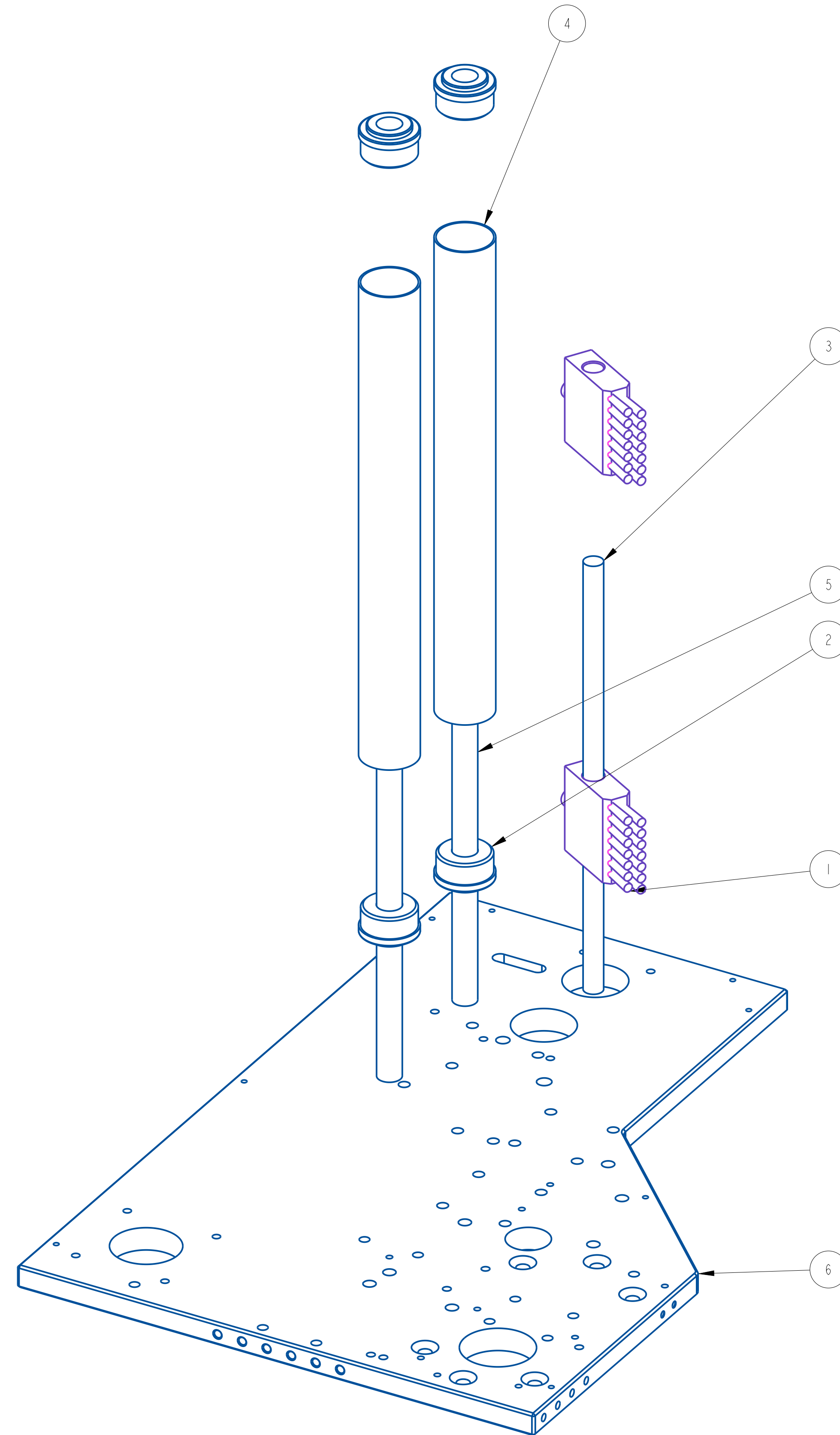

REV	DATE	DESCRIPTION	BY
A	Jan-09-26	NEW DRAWING	TAZ

THIS IS A PRO-ENGINEER DOCUMENT AND MAY NOT BE MODIFIED MANUALLY

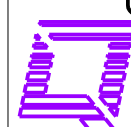
UNLESS OTHERWISE SPECIFIED DIMENSIONAL TOLERANCE .X ± .1 .XX ± .01 .XXX ± .005 ANGLES ± .30° SURFACE FINISH 125 BREAK ALL EDGES .005/0.15 CORNER RADIUS .010/0.30 ALL ANGLES ARE 90°	 QUADREL LABELING SYSTEMS 7670 JENTHER DRIVE MENTOR, OHIO 44060 (440) 602-4700	SCALE: 1/2
		DATE: Jan-09-26
		DRW BY: TAZ
		CHK BY:
		APPR BY:
Q60 12" SIDE PLATE RH		
MAT'L	21753A-005	21753A-005

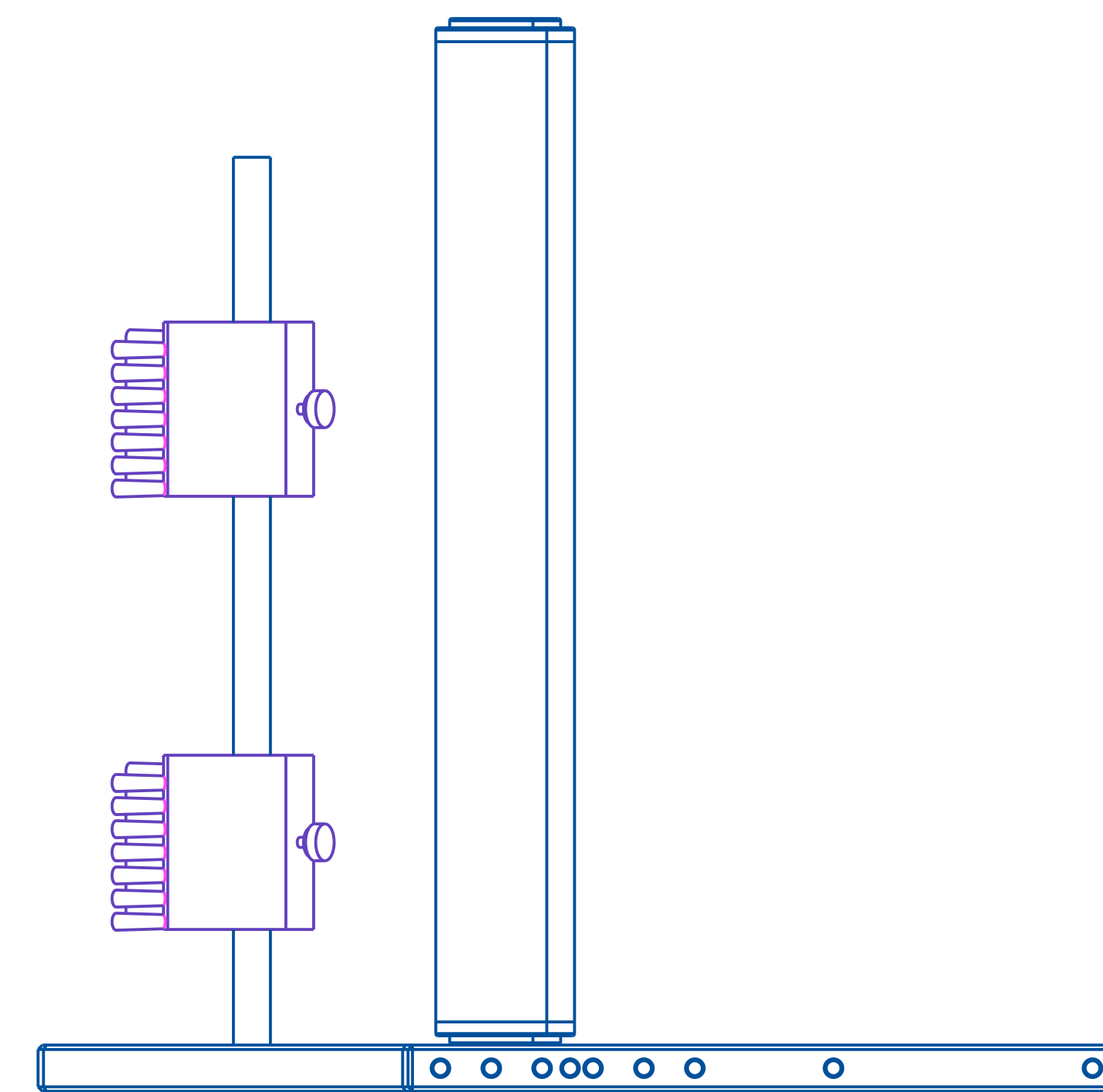
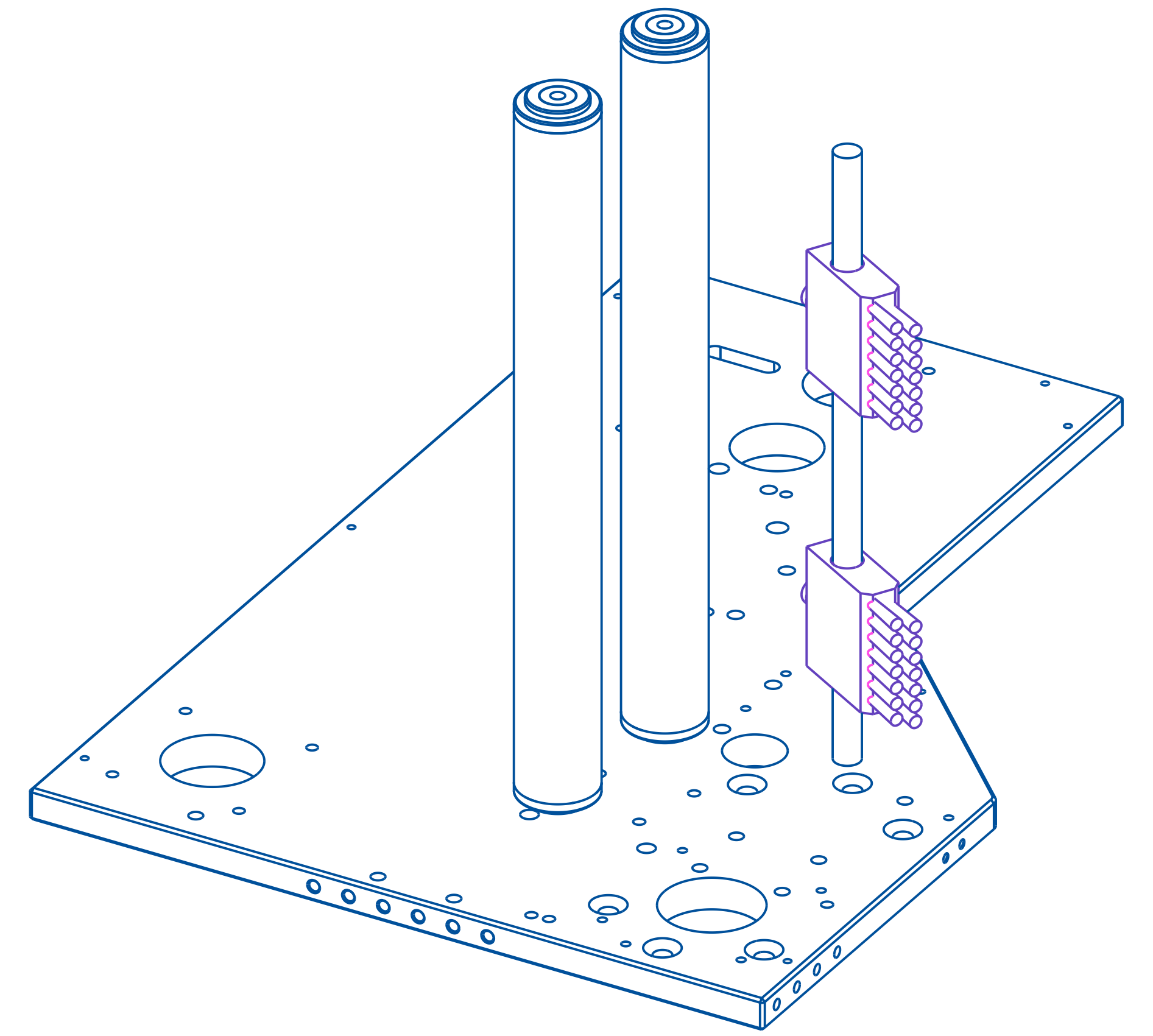
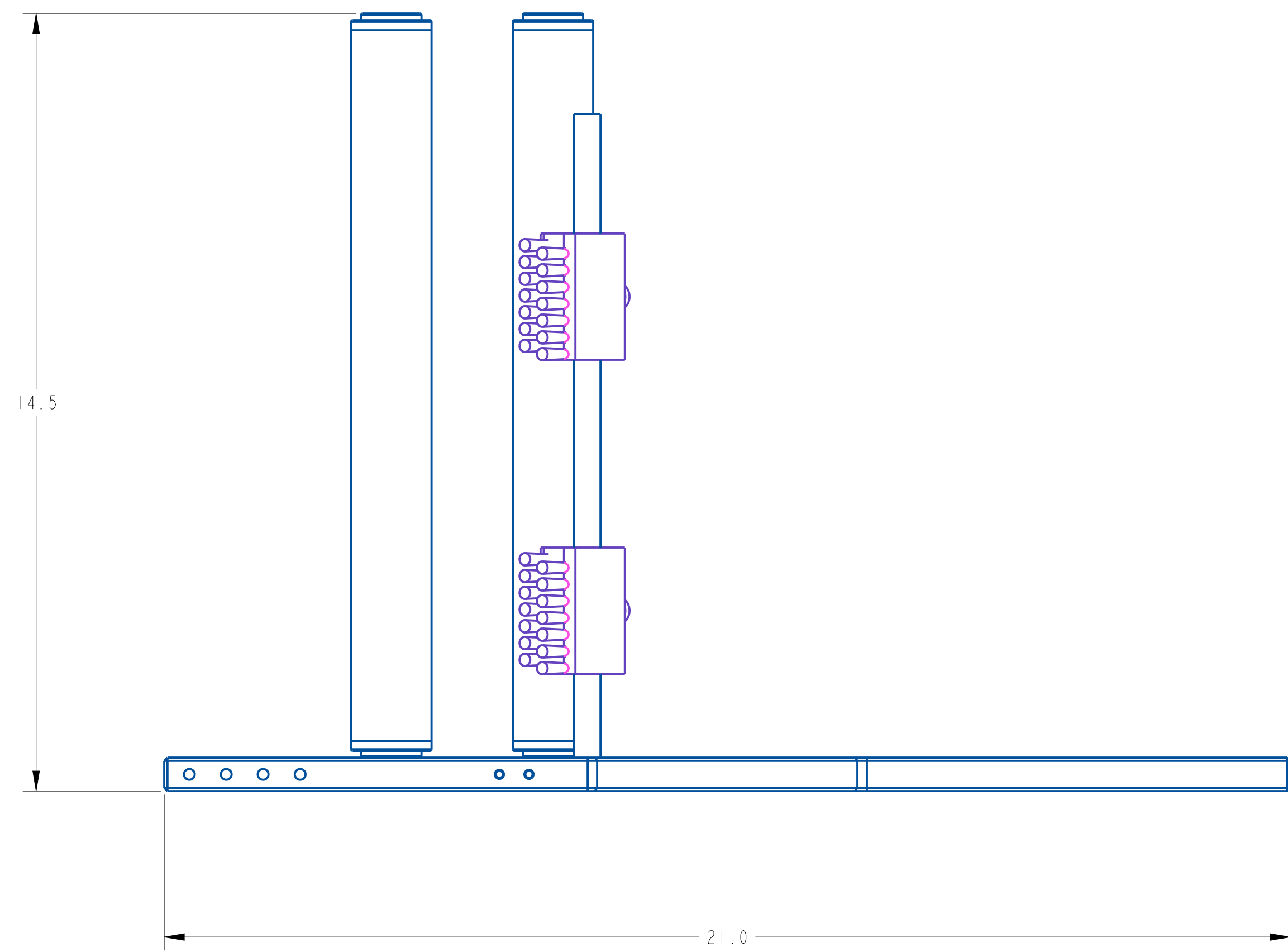
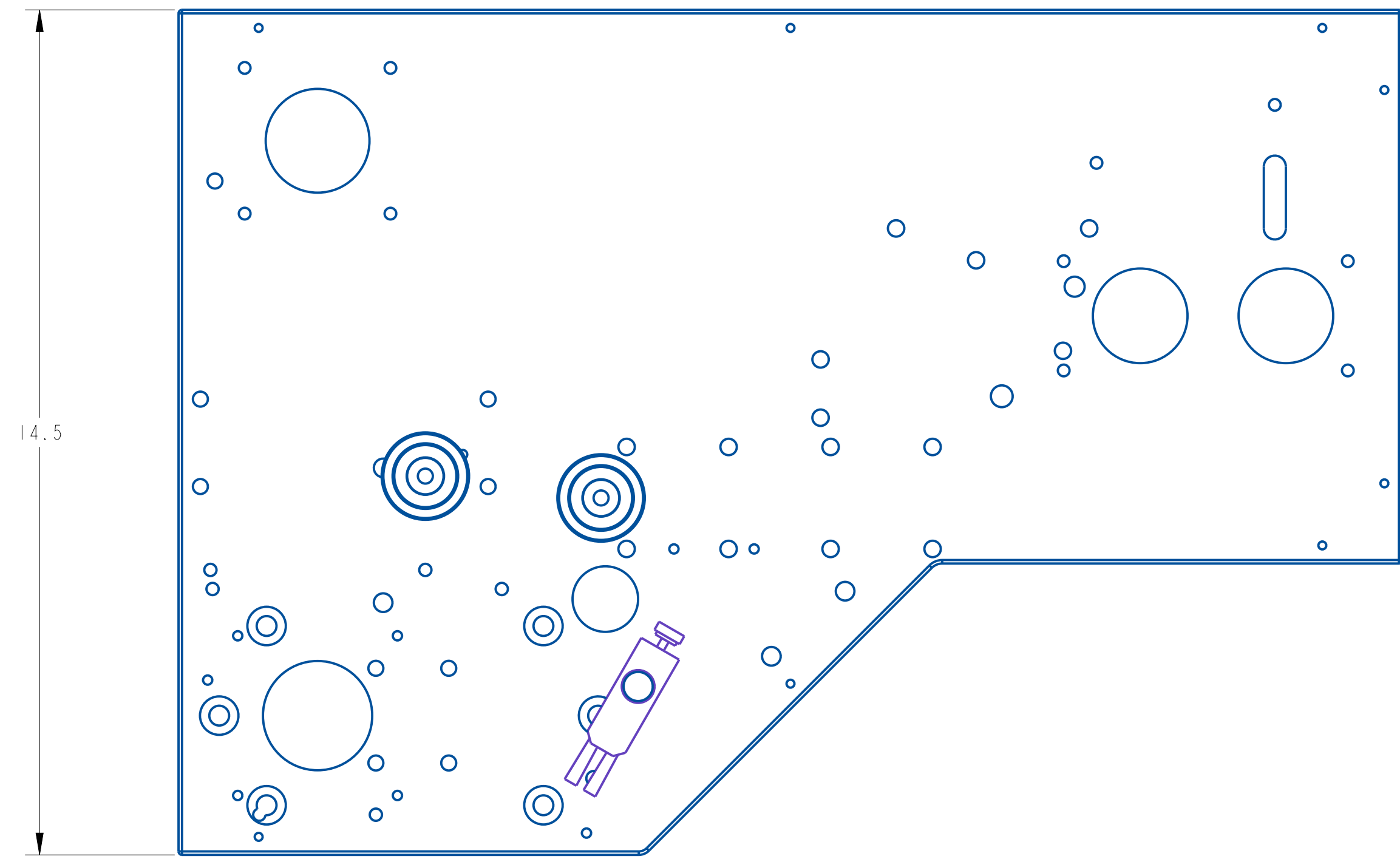

REV	DATE	DESCRIPTION	BY
A	Jan-09-26	NEW DRAWING	TAZ

THIS IS A PRO-ENGINEER DOCUMENT AND MAY NOT BE MODIFIED MANUALLY

UNLESS OTHERWISE SPECIFIED
DIMENSIONAL TOLERANCE
X ± .1
XX ± .01
XXX ± .005
ANGLES ± .30°
SURFACE FINISH 125
BREAK ALL EDGES .005/.015
CORNER RADIUS .010/.030
ALL ANGLES ARE 90°

QUADREL LABELING SYSTEMS
7670 JENTHER DRIVE
MENTOR, OHIO 44060
(440) 602-4700

SCALE: 1/2
DATE: Jan-09-26
DRW BY: TAZ
CHK BY:
APPR BY:

Q60 12" SIDE PLATE RH

MAT'L 21753A-005 21753A-005

ASSEMBLY TITLE: Q60 UNWIND & DANCER ASSEMBLY

DRAWING NO.: 7" Web D21434-000 & D22103-000

GENERAL FUNCTION:

- Unwind flange provides support for label rolls (side application)
- Dual flanges prevent roll and label movement (top application)
- Dancer arm prevents roll run-away.
- Idler roller with guide collars guides web through slot sensor.
- Brake brush prevents web buckling through slot sensor.

SET UP AND ADJUSTMENTS:

- Move flange to required height and tighten set screw in flange hub.
- For top labeling, add second flange and tighten ratchet knob.
- Adjust dancer tension by turning check nut so that dancer roll snaps back to braking position when labeling head is threaded.
- Slide brake brush so that center of brush lines up with center of web. Rotate brush to provide web tension, then lock into place using the locking knob.
- Position guide collars on idler roll, one slightly above, the other slightly below the web.

DANCER TENSION ADJUSTMENT LOCATION:

- **The unwind tension adjustment is located on the middle underside of the Q60 head. Use the knurled ring to adjust the dancer tension.**

MAINTENANCE:

- Clean all the parts that may acquire glue residue

TROUBLESHOOTING:

PROBLEM

- Unwind roll run-away
- Unwind roll not stopping
- Drive roll stalling
- Brush taking fixed shape

WHAT TO DO

- Tighten dancer spring, check nut or replace dancer spring, if necessary.
- Replace brake ring-belt if broken, or unevenly worn.
- Release web tension produced by brake brush.
- Turn brush around

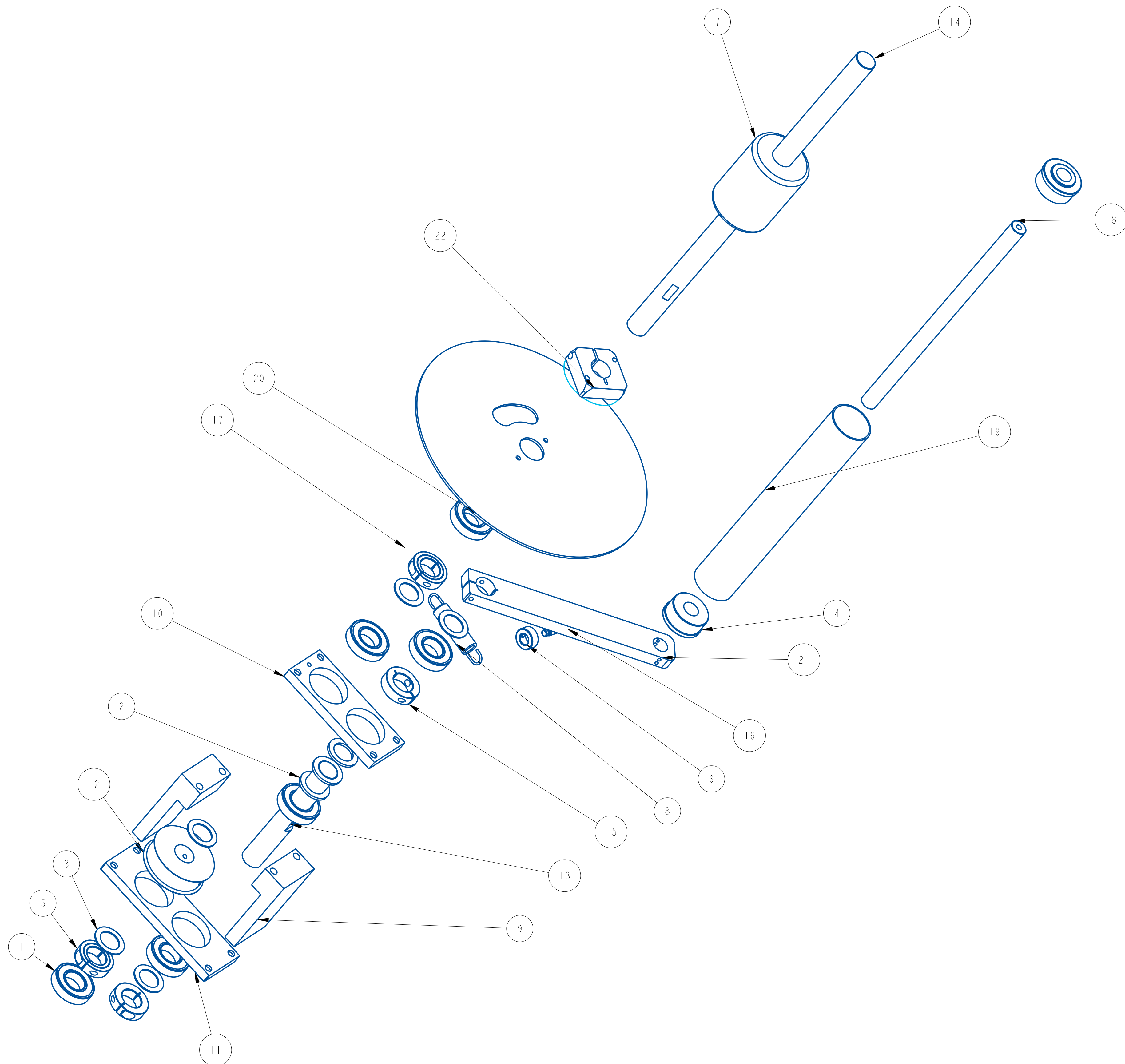

ITEM	QTY	PART NO.	DESCRIPTION	PARENT ITEM
1	6	111064-000	BEARING, BANDED THRUST BALL	21754B-115
2	3	151011-000	BEARING, THRUST WASHER	21754B-115
3	5	151038-000	BEARING, THRUST WASHER	21754B-115
4	2	181090-000	BEARING, ROLL END	21754B-115
5	3	361170-000	COLLAR, 1 IN. ID ONE-PIECE CLAMP	21754B-115
6	1	362161-000	COLLAR, SETSCREW, 1/2 IN. ID	21754B-115
7	1	791863-003	CORE CHUCK	21754B-115
8	1	811216-000	EXTENSION SPRING, STAINLESS	21754B-115
9	2	A20585-013	SUPPORT SPACER	21754B-115
10	1	A20590-014	BEARING PLATE	21754B-115
11	1	A20590-015	BEARING PLATE	21754B-115
12	1	A20591-012	UNWIND BRAKE DRUM	21754B-115
13	1	A20592-013	UNWIND DANCER SHAFT	21754B-115
14	1	A20593-414	UNWIND SHAFT	21754B-115
15	1	A20595-82350	COLLAR REWORK	21754B-115
16	1	A20596-006	1/2 X 1-1/2 LG. SHOULDER BOLT	21754B-115
17	1	A23406-112	SUPPLY HUB REWORK	21754B-115
18	1	A25220-004	SHAFT IDLER	21754B-115
19	1	A25696-011	IDLER ROLLER	21754B-115
20	1	B20980-015	12" UNWIND FLANGE	21754B-115
21	1	B21113-314	DANCER ARM	21754B-115
22	1	B21931-112	HUB REWORK	21754B-115

REV	DATE	DESCRIPTION	BY
B	Apr-30-25	ADDED CORE CHUCK, 811216-000	TAZ
A	Mar-07-25	NEW DRAWING	TAZ

THIS IS A PRO-ENGINEER DOCUMENT AND MAY NOT BE MODIFIED MANUALLY

UNLESS OTHERWISE SPECIFIED DIMENSIONAL TOLERANCE .X ± .1 .XX ± .01 .XXX ± .005 ANGLES ± 30° SURFACE FINISH 125 BREAK ALL EDGES .005/.015 CORNER RADIUS .010/.030 ALL ANGLES ARE 90°	7670 JENTHER DRIVE MENTOR, OHIO 44060 (440) 602-4700	SCALE: 3/8
		DATE: Mar-07-25
		DRW BY: TAZ
		CHK BY:
Q60/Q62 12" UNWIND & DANCER ASSEMBLY		APPR BY:
MAT'L	21754B-115	21754B-115

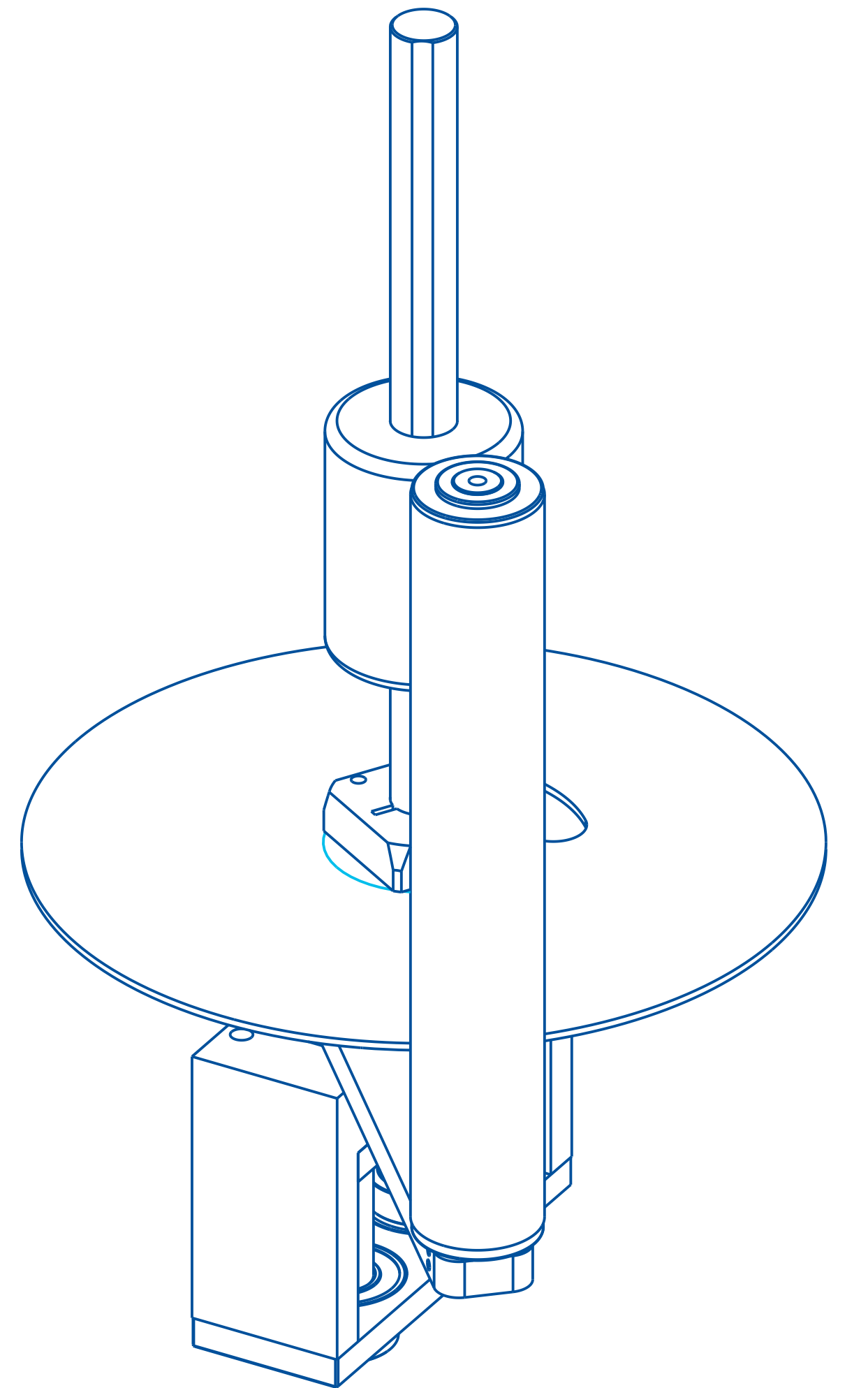
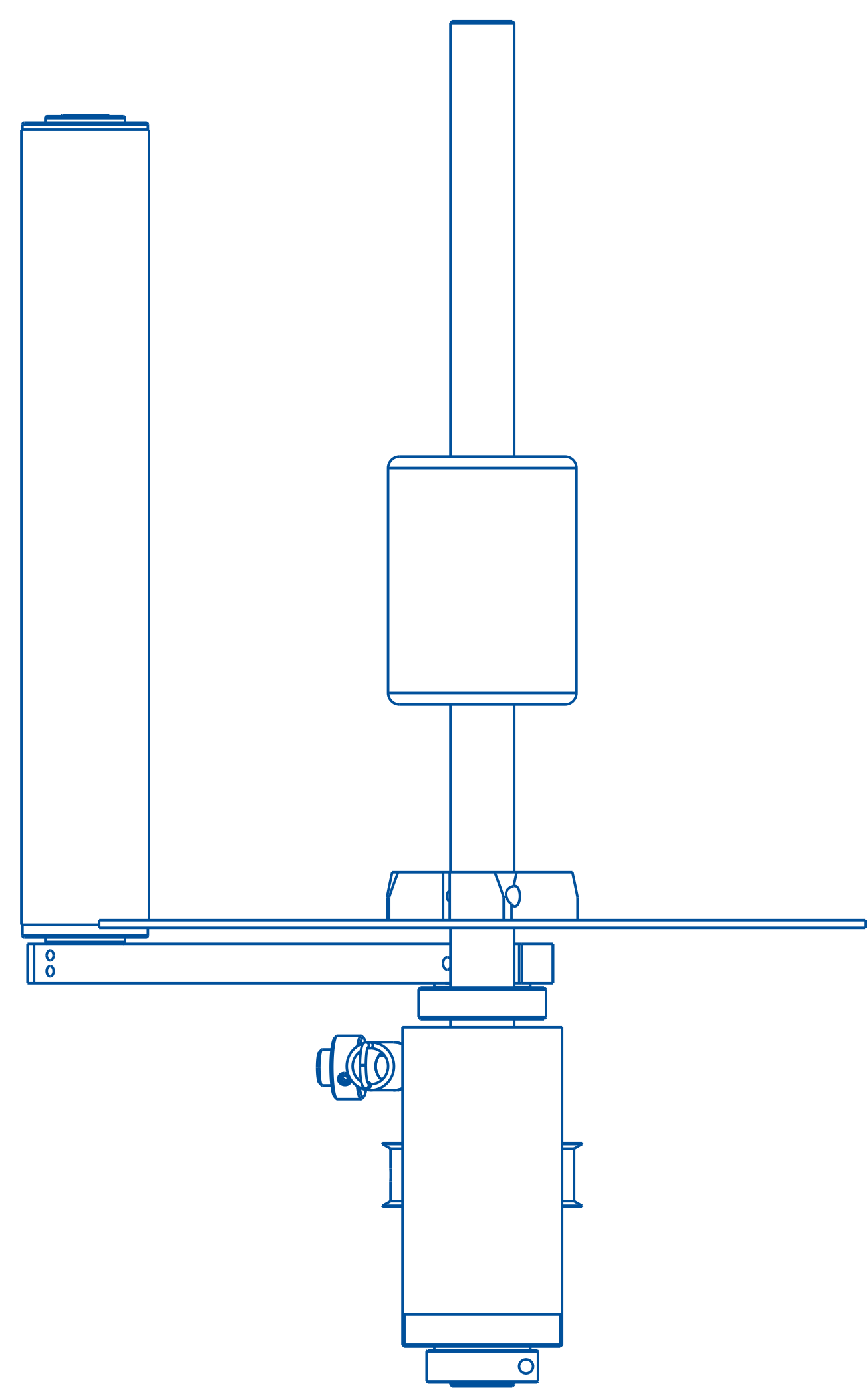
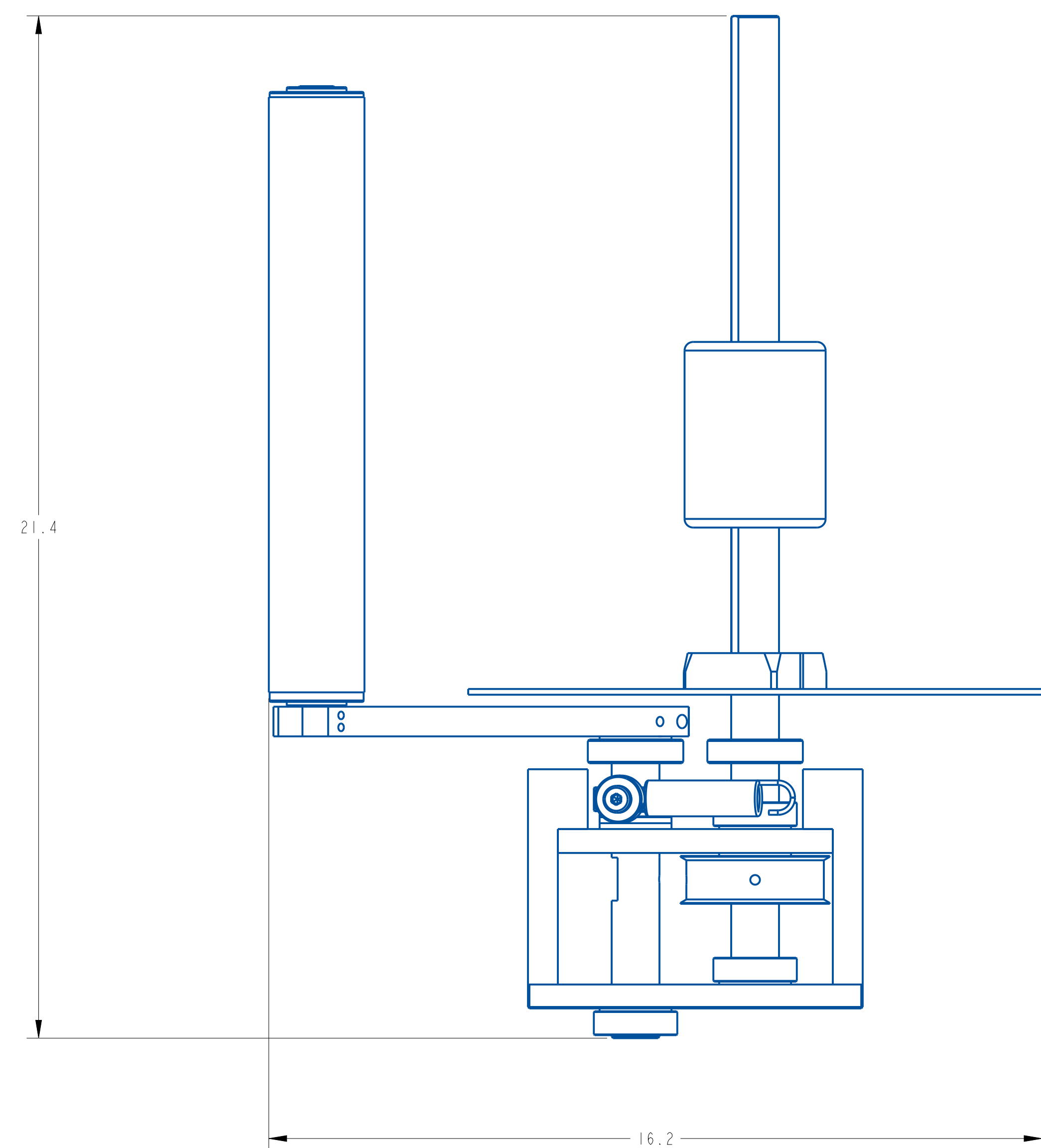
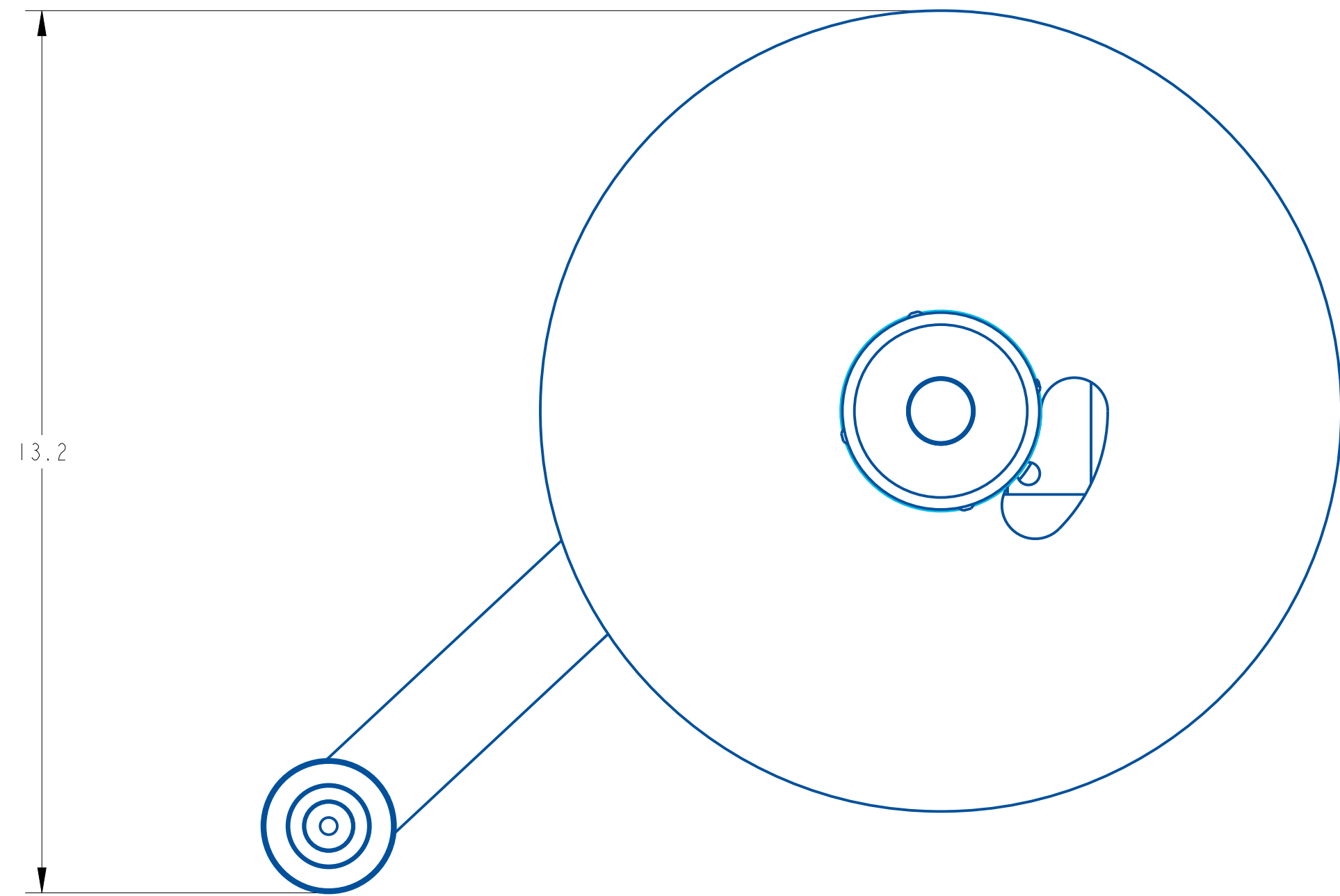

B	Apr-30-25	ADDED CORE CHUCK, 811216-000	TAZ
A	Mar-07-25	NEW DRAWING	TAZ
REV	DATE	DESCRIPTION	BY

THIS IS A PRO-ENGINEER DOCUMENT AND MAY NOT BE MODIFIED MANUALLY

UNLESS OTHERWISE SPECIFIED
DIMENSIONAL TOLERANCE
X ± .1
XX ± .01
XXX ± .005
ANGLES ± .30°
SURFACE FINISH 125
BREAK ALL EDGES .005/.015
CORNER RADIUS .010/.030
ALL ANGLES ARE 90°

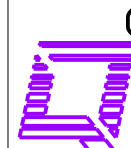

QUADREL LABELING SYSTEMS
7670 JENTHER DRIVE
MENTOR, OHIO 44060
(440) 602-4700

SCALE: 1/2
DATE: Mar-07-25
DRW BY: TAZ
CHK BY:
APPR BY:

Q60/Q62 12" UNWIND & DANCER ASSEMBLY

MAT'L

21754B-115

21754B-115

ITEM	QTY	PART NO.	DESCRIPTION	PARENT ITEM
1	1	A20583-100	QUICK LOCK COLLAR	22604-004
2	1	A20586-000	WHITE NYLON SLUG	22604-004
3	1	B20980-201	UNWIND FLANGE	22604-004

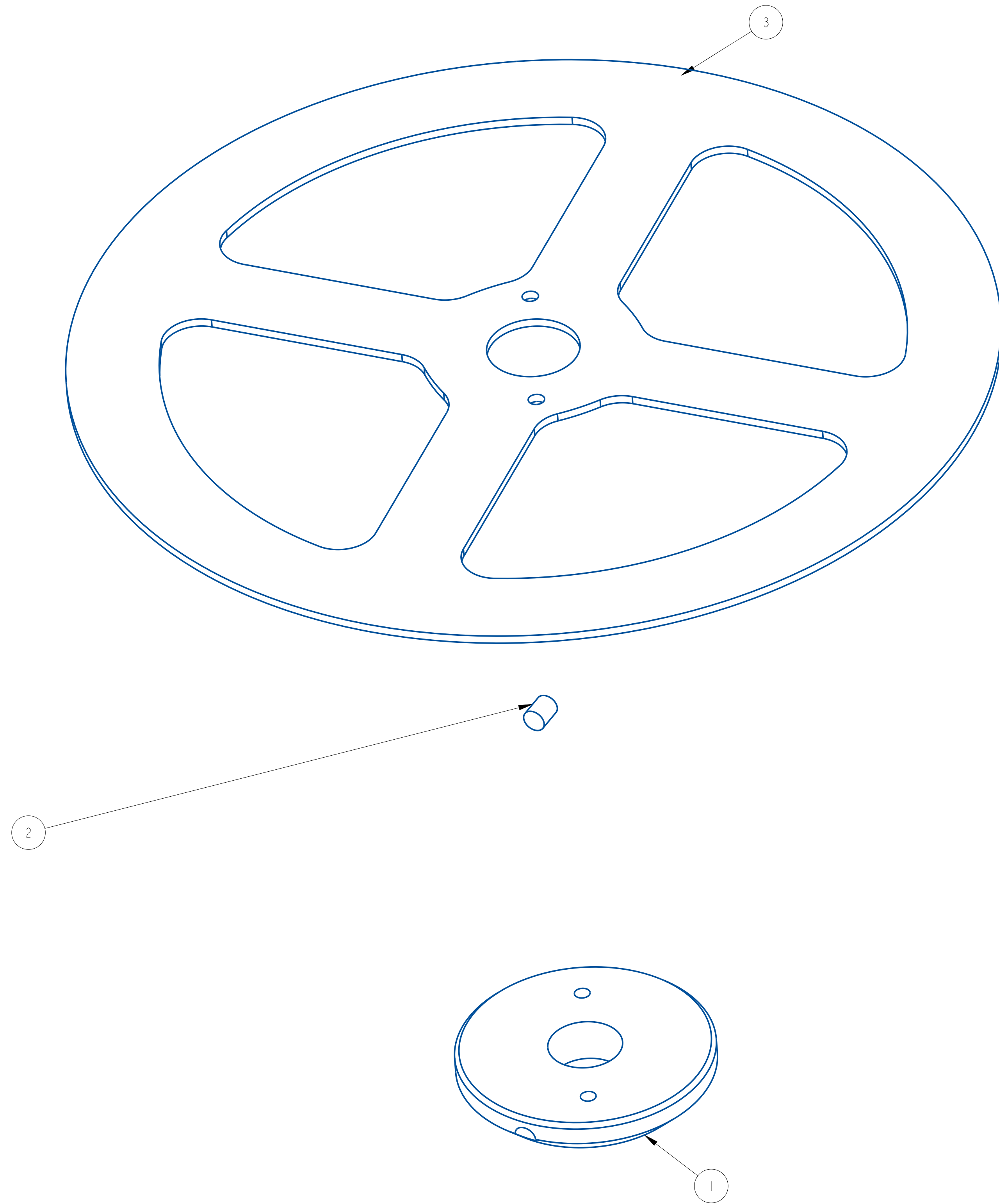

REV	DATE	DESCRIPTION	BY
A	Mar-10-25	NEW DRAWING	TAZ

THIS IS A PRO-ENGINEER DOCUMENT AND MAY NOT BE MODIFIED MANUALLY

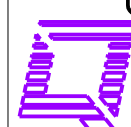
UNLESS OTHERWISE SPECIFIED DIMENSIONAL TOLERANCE .X ± .1 .XX ± .01 .XXX ± .005 ANGLES ± .30° SURFACE FINISH 125 BREAK ALL EDGES .005/0.15 CORNER RADIUS .010/0.30 ALL ANGLES ARE 90°	 7670 JENTHER DRIVE MENTOR, OHIO 44060 (440) 602-4700	SCALE: 1/1
		DATE: Mar-10-25
		DRW BY: TAZ
		CHK BY: 03/15/2025-SEM
12" OUTSIDE FLANGE KIT 1" BORE		MAT'L
		22604-004

Ø12.5

Ø1.0

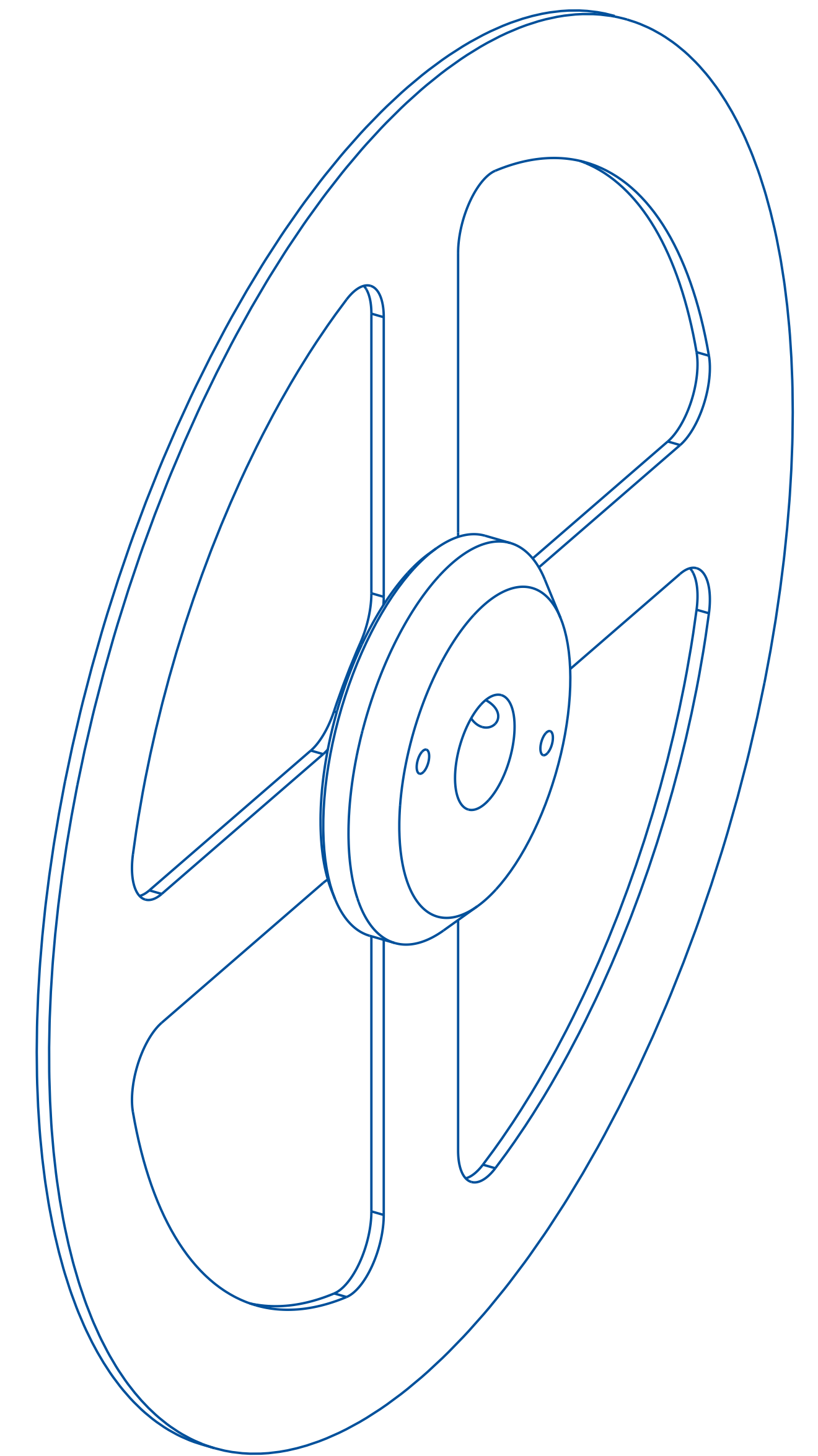
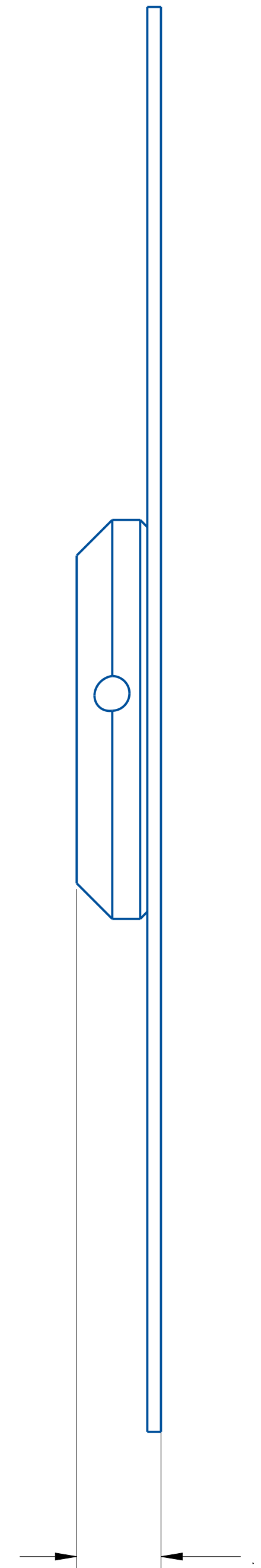
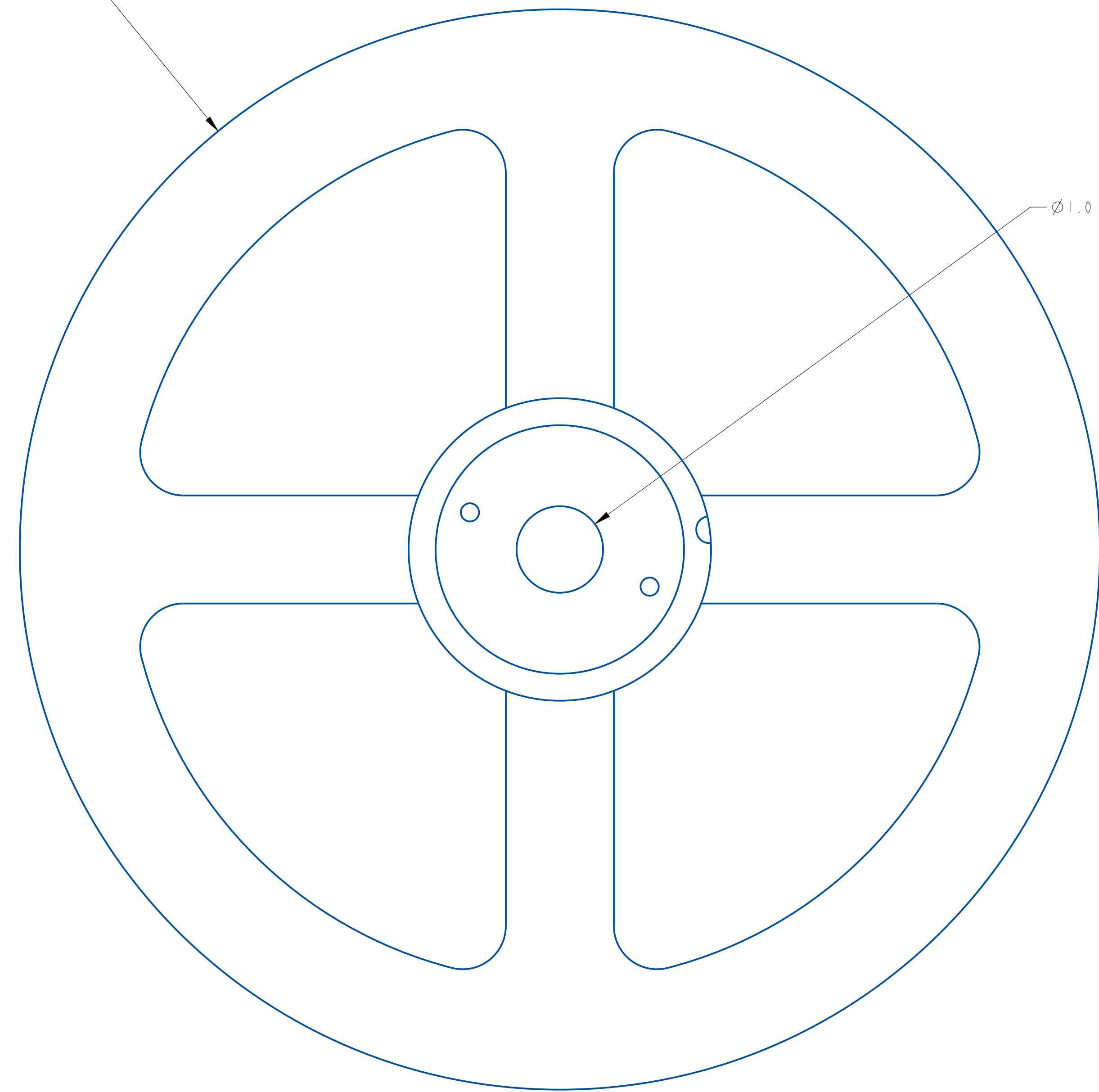

REV	DATE	DESCRIPTION	BY
A	Mar-10-25	NEW DRAWING	TAZ

THIS IS A PRO-ENGINEER DOCUMENT AND MAY NOT BE MODIFIED MANUALLY

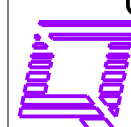
<small>UNLESS OTHERWISE SPECIFIED DIMENSIONAL TOLERANCE</small> X ± .1 XX ± .01 XXX ± .005 ANGLES ± .30° SURFACE FINISH 125 BREAK ALL EDGES .005/.015 CORNER RADIUS .010/.030 ALL ANGLES ARE 90°	 QUADREL LABELING SYSTEMS 7670 JENTHER DRIVE MENTOR, OHIO 44060 (440) 602-4700	SCALE: 1/1
		DATE: Mar-10-25
		DRW BY: TAZ
		CHK BY: 03/15/2025-SEM
12" OUTSIDE FLANGE KIT 1" BORE		APPR BY:
MAT'L	22604-004	22604-004

ASSEMBLY TITLE: Q60 PEEL PLATE ASSEMBLY

DRAWING NO.: 7" Web C20812-000

GENERAL FUNCTION:

- The peel plate separates the label from the liner and puts the label in a "Flag" position.
- The mounting rods support the slot sensor assembly.
- The guide collars and the idler roller guide the web position over the peel plate
- The pivot pin provides for yoke mounting of the labeling head.

SET UP AND ADJUSTMENTS:

- On machines so equipped, the peel plate may be pivoted at various angles relating to the product by loosening the peel plate mounting bar. (The peel plate of all other models is mounted at a fixed angle and cannot be adjusted)
- To advance label flag on peel plate, move the slot sensor towards the peel plate. To decrease label flag, move slot sensor away from the peel plate.
- Position guide collars on idler roll, one slightly above and the other slightly below the web.

MAINTENANCE:

- Clean all the parts that may acquire labels or glue residue.

TROUBLESHOOTING:

PROBLEM

- Too much label flag at peel plate
- Too little label flag at peel-
- Web moving up and down peel plate

WHAT TO DO

- Move slot sensor away from peel edge
- Move slot sensor towards peel plate edge
- Make sure guide collars are properly positioned on idler roll.

ITEM	QTY	PART NO.	DESCRIPTION	PARENT ITEM
1	6	181063-000	BEARING, ROLL END	21720-012
2	4	361198-000		21720-012
3	2	A22065-000	PEEL PLATE MOUNTING PLATE	21720-012
4	2	A22066-000	WASHER	21720-012
5	1	A22094-012	PEEL PLATE ROD MTG BAR, 12"	21720-012
6	3	A22102-112	P.P. IDLER SHAFT	21720-012
7	1	A23946-012	PEEL PLATE MOUNTING BAR, 12"	21720-012
8	3	B20740-112	IDLER ROLLER-(PEEL PLATE)	21720-012
9	1	B21199-019	PEEL PLATE, 12"	21720-012

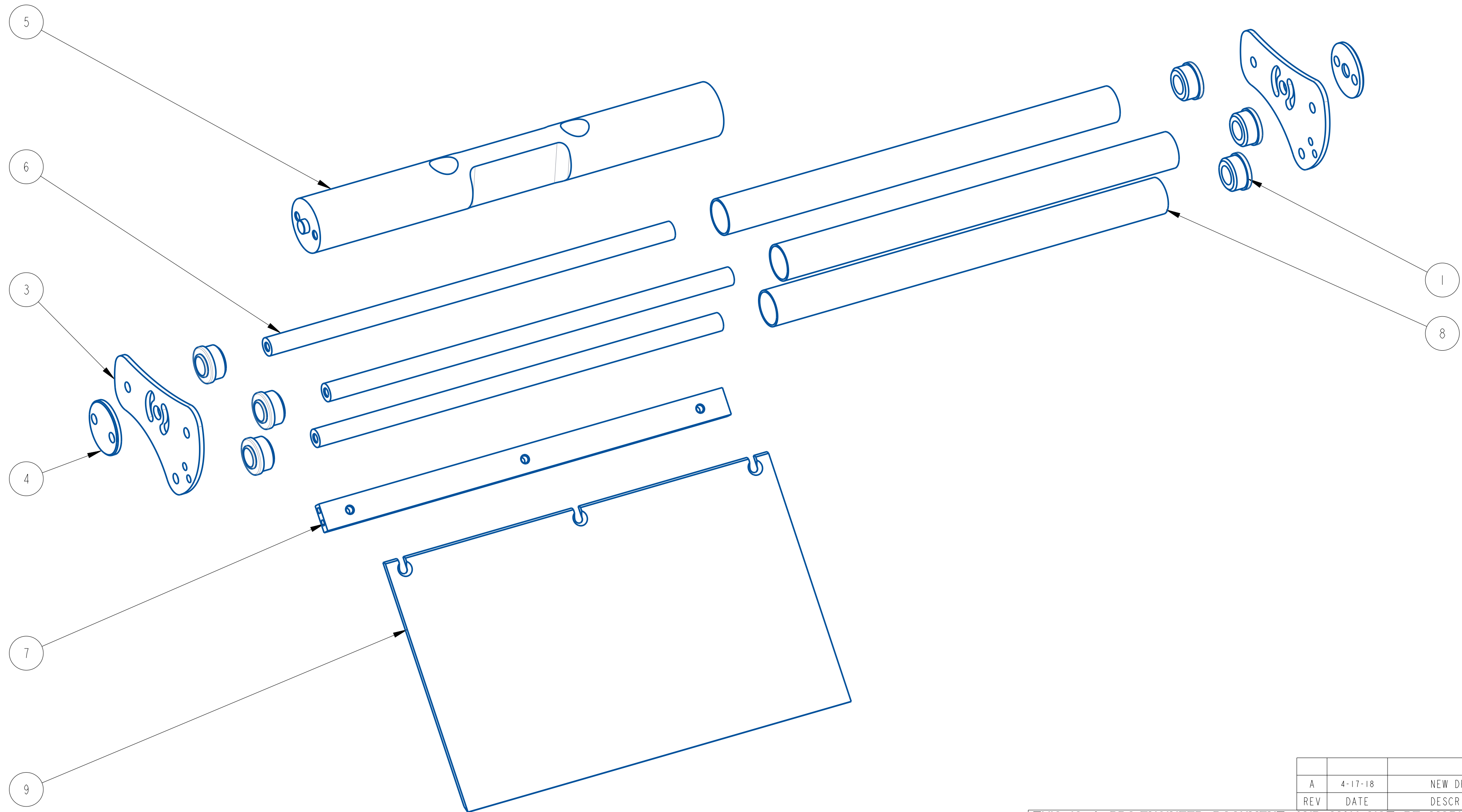

REV	DATE	DESCRIPTION	BY
A	4-17-18	NEW DRAWING	CRT

THIS IS A PRO-ENGINEER DOCUMENT AND MAY NOT BE MODIFIED MANUALLY

UNLESS OTHERWISE SPECIFIED DIMENSIONAL TOLERANCE .X ± .1 .XX ± .01 .XXX ± .005 ANGLES ± 30° SURFACE FINISH 125 BREAK ALL EDGES .005/.015 CORNER RADIUS .010/.030	 QUADREL LABELING SYSTEMS 7670 JENTHER DRIVE MENTOR, OHIO 44060 (440) 602-4700	SCALE: 1/2
		DATE: Apr-17-18
		DRW BY: CRT
		CHK BY: 03/15/2025-SEM
		APPR BY:
12" PEEL PLATE ASSEMBLY		
MAT'L		21720-012

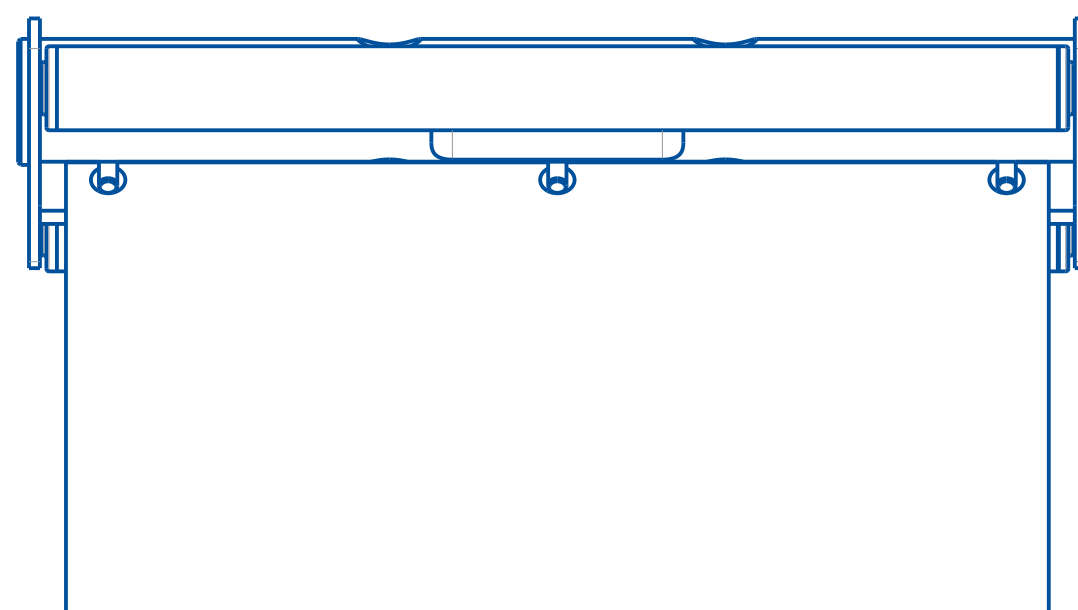
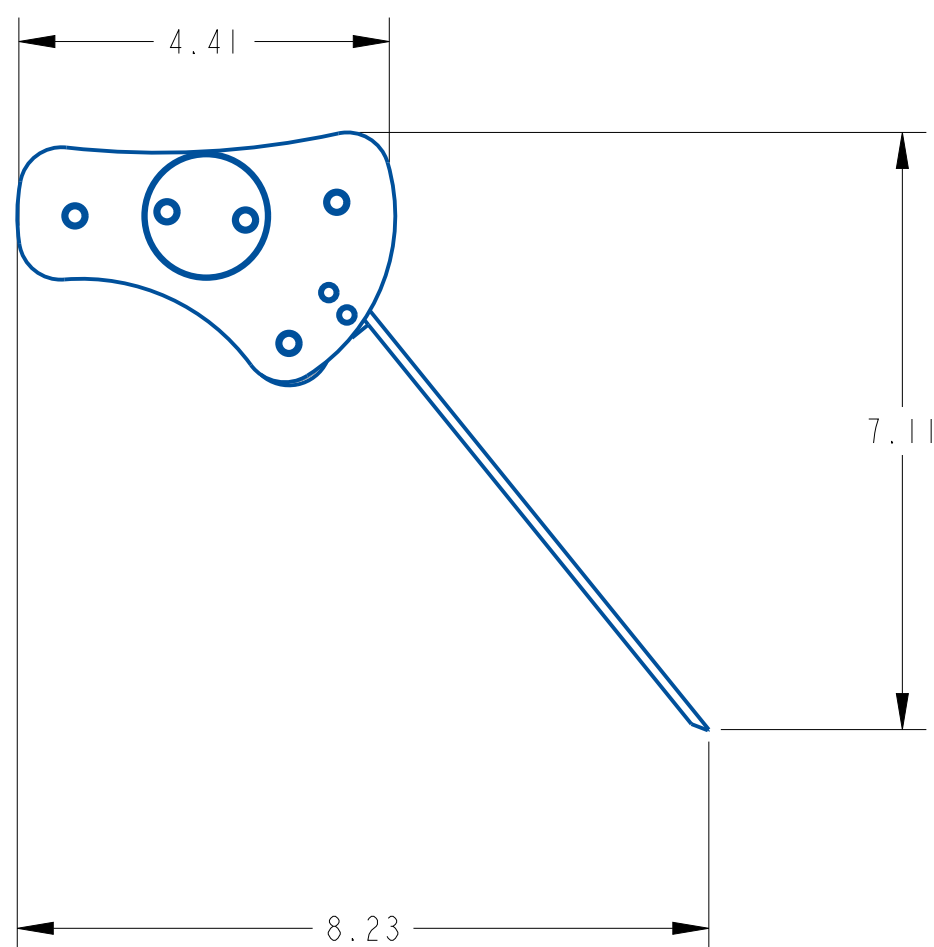
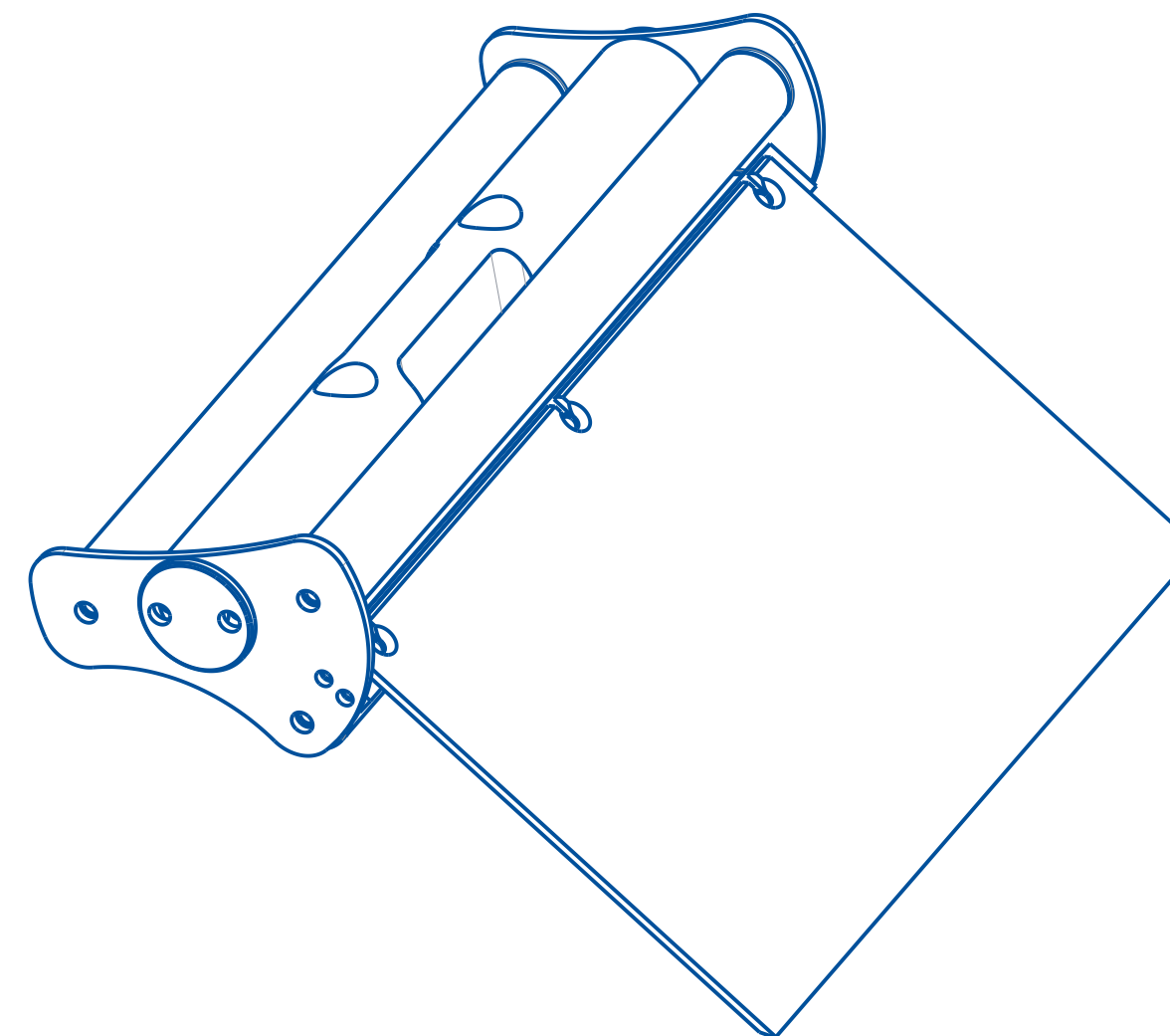
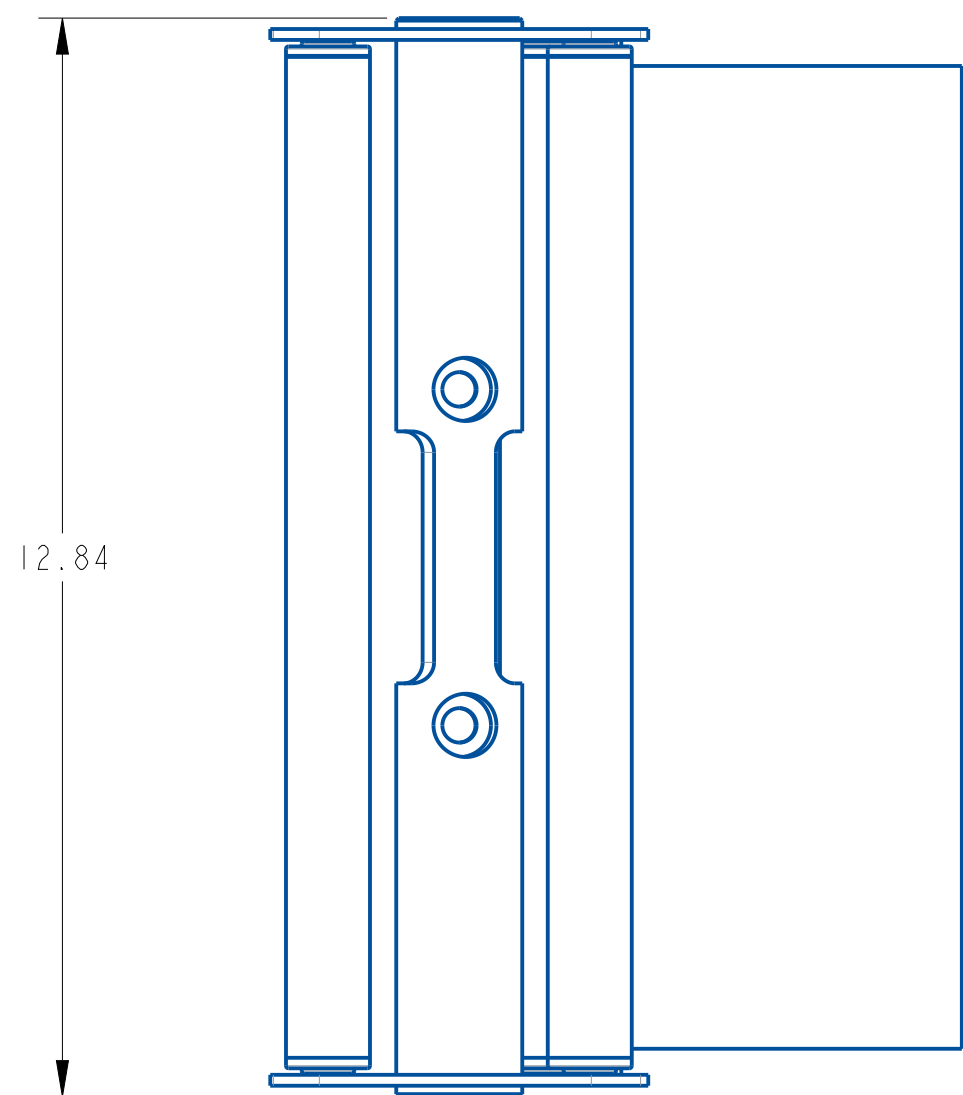

REV	DATE	DESCRIPTION	BY
A	4-17-18	NEW DRAWING	CRT

THIS IS A PRO-ENGINEER DOCUMENT AND MAY NOT BE MODIFIED MANUALLY

UNLESS OTHERWISE SPECIFIED DIMENSIONAL TOLERANCE .X ± .1 .XX ± .01 .XXX ± .005 ANGLES ± 30° SURFACE FINISH 125 BREAK ALL EDGES .005/.015 CORNER RADIUS .010/.030	 QUADREL LABELING SYSTEMS 7670 JENTHER DRIVE MENTOR, OHIO 44060 (440) 602-4700	SCALE: 7/16
		DATE: Apr-17-18
		DRW BY: CRT
		CHK BY: 03/15/2025-SEM
		APPR BY:
12" PEEL PLATE ASSEMBLY		
MAT'L		21720-012

ITEM	QTY	PART NO.	DESCRIPTION	PARENT ITEM
1	1	A23946-013	PEEL PLATE MOUNTING BAR, 12"	22898-000
2	2	A28427-000	PRESSURE SHOE SUPPORT BLOCK	22898-000
3	1	B21199-022	PEEL PLATE, 7"	22898-000

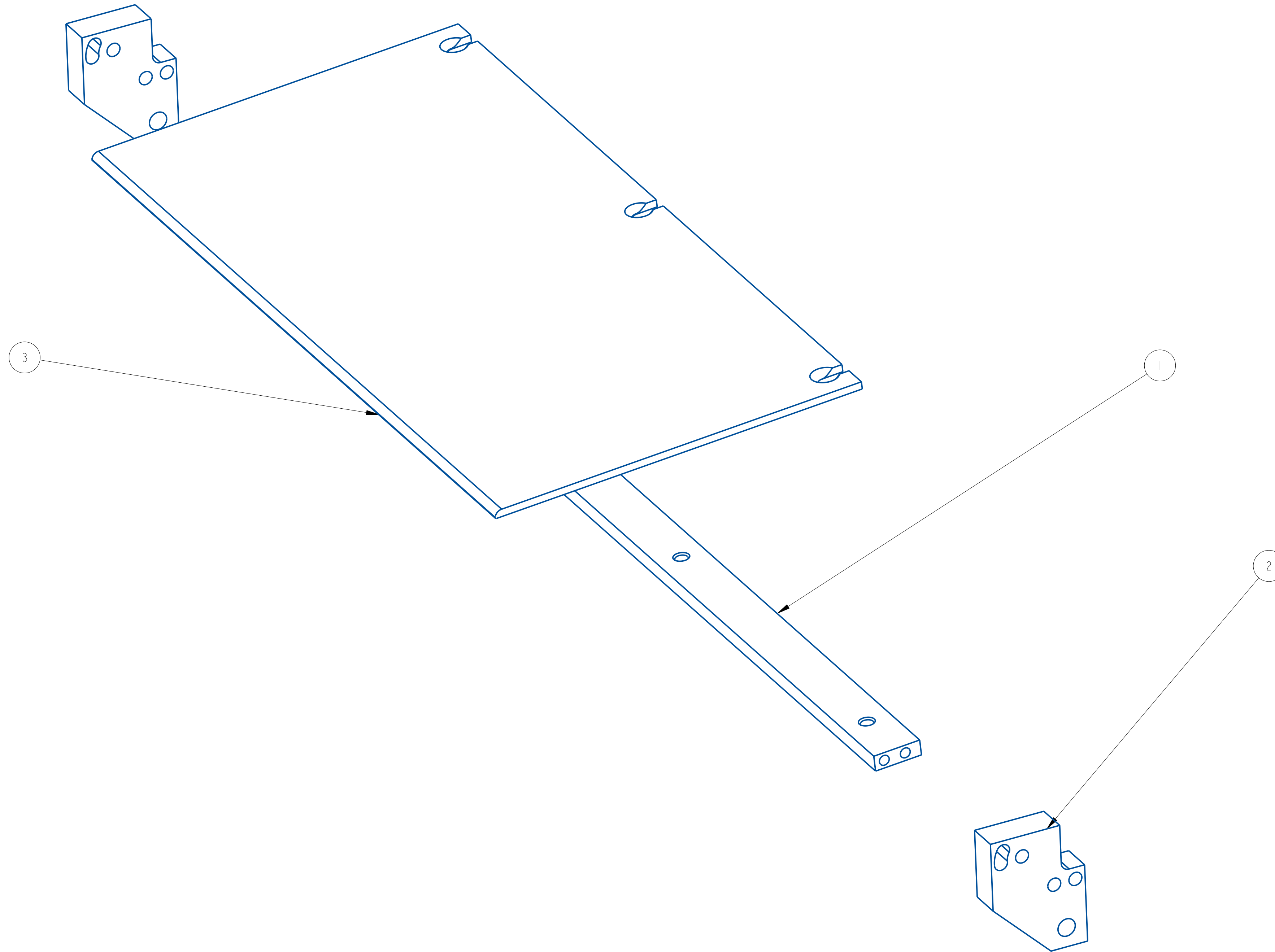

REV	DATE	DESCRIPTION	BY
A	Apr-29-25	NEW DRAWING	TAZ

THIS IS A PRO-ENGINEER DOCUMENT AND MAY NOT BE MODIFIED MANUALLY

UNLESS OTHERWISE SPECIFIED DIMENSIONAL TOLERANCE .X ± .1 .XX ± .01 .XXX ± .005 ANGLES ± .30° SURFACE FINISH 125 BREAK ALL EDGES .005/ .015 CORNER RADIUS .010/ .030 ALL ANGLES ARE 90°	QUADREL LABELING SYSTEMS 7670 JENTHER DRIVE MENTOR, OHIO 44060 (440) 602-4700		SCALE: 1/1 DATE: Apr-29-25 DRW BY: TAZ CHK BY: APPR BY:
	12" PIVOTING PRESSURE SHOE		
	MAT'L	22898-000	22898-000

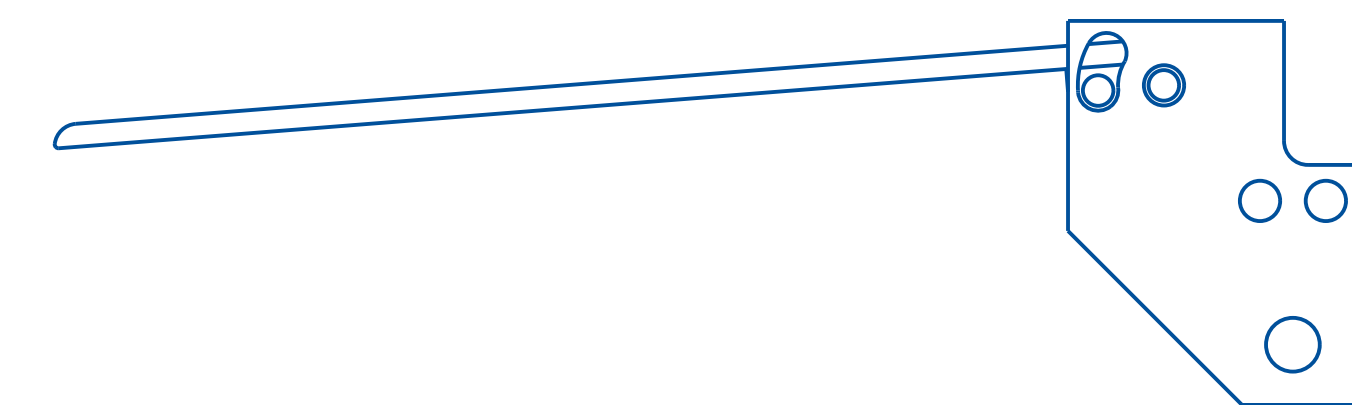
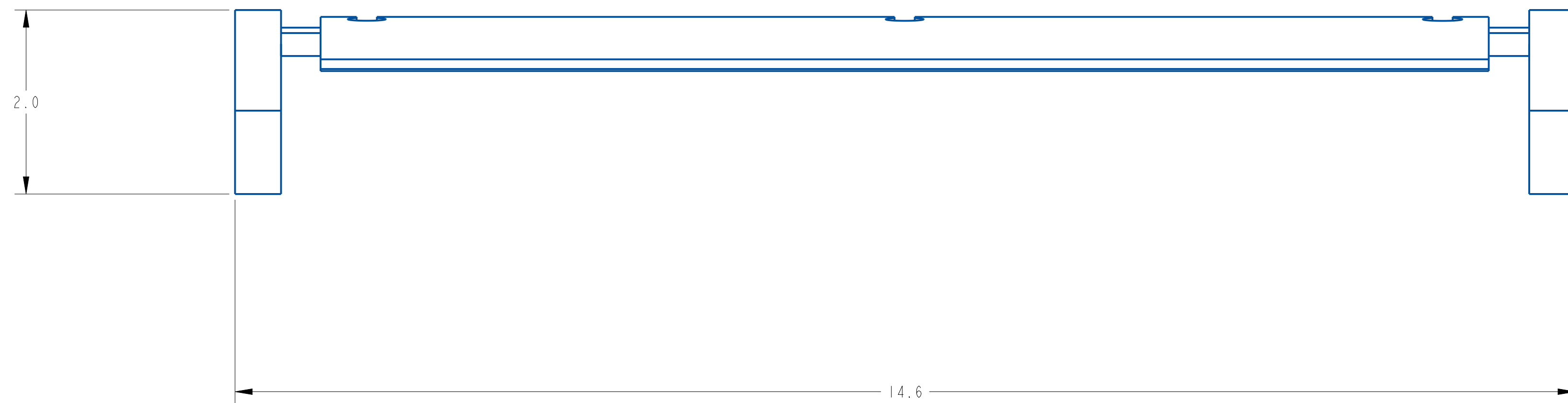
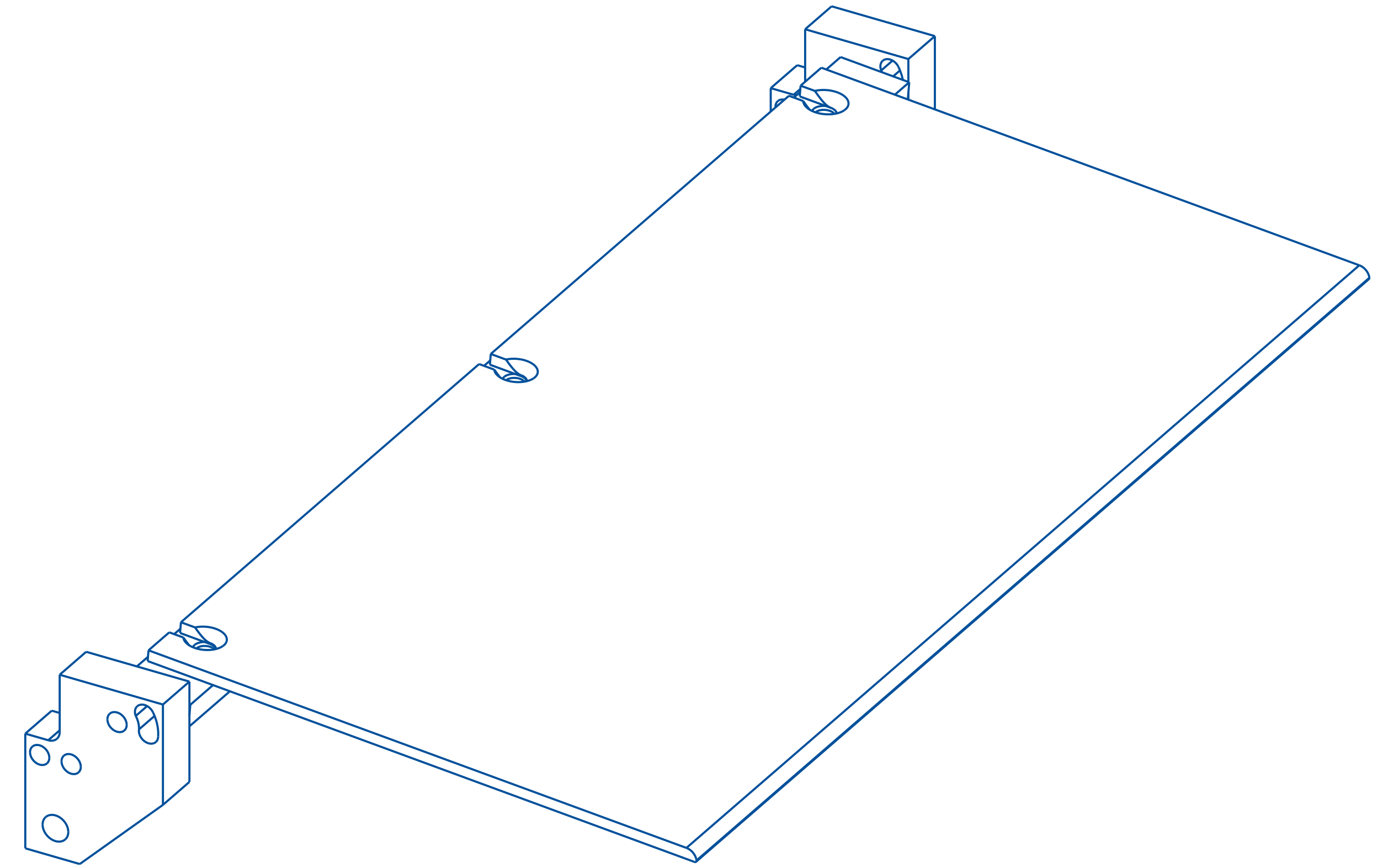
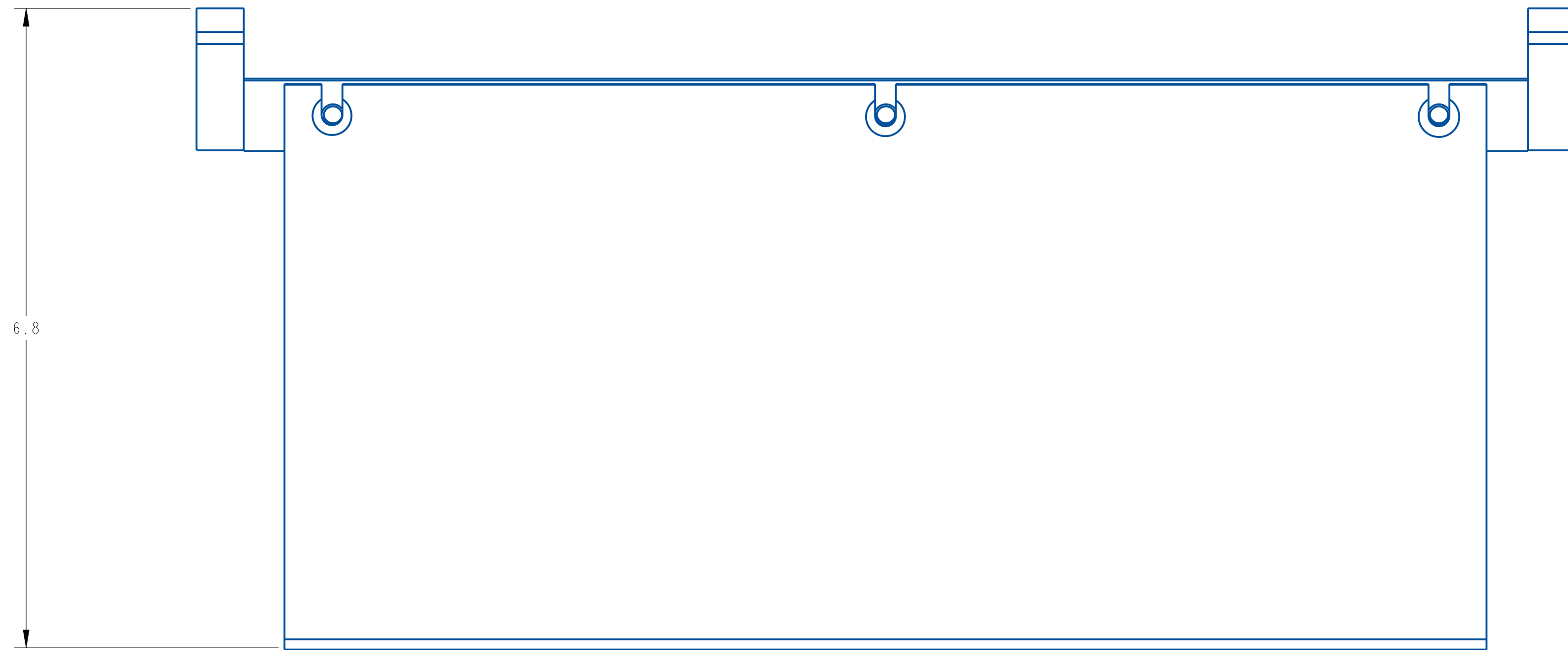

REV	DATE	DESCRIPTION	BY
A	Apr-29-25	NEW DRAWING	TAZ

THIS IS A PRO-ENGINEER DOCUMENT AND MAY NOT BE MODIFIED MANUALLY

UNLESS OTHERWISE SPECIFIED DIMENSIONAL TOLERANCE	.XX ± .01 .XXX ± .005 ANGLES ± .30° SURFACE FINISH 125 BREAK ALL EDGES .005/ .015 CORNER RADIUS .010/ .030 ALL ANGLES ARE 90°	QUADREL LABELING SYSTEMS 7670 JENTHER DRIVE MENTOR, OHIO 44060 (440) 602-4700	SCALE: 1/1 DATE: Apr-29-25 DRW BY: TAZ APPR BY:
12" PIVOTING PRESSURE SHOE			
MAT'L	22898-000		22898-000

ASSEMBLY TITLE: FIXED BRUSH IMPRESSER

DRAWING NO.:

GENERAL FUNCTION:

- The fixed roller impresser is an option used in applications where a secondary wipe down or label wipe is necessary.

SET UP AND ADJUSTMENTS:

- When installed, the brush assembly will be mounted by an adjustable clamp. The mounting assembly is fastener to the option rail located on the peel plate side wall.
- Four axis of adjustment is available by loosening the set screw locking the roller arm in place.
- Locate the brush as necessary and re-tighten the clamping screws.
- Run a product through the brush area and insure the brush layed on the product but do not impede product travel. The brush can be adjusted too close to the product which will prevent the product from smoothly traversing through the brush area.

MAINTENANCE:

- Keep the brush free of label flash, glue and debris. This will prevent jamming and web tears.

NOTE: Exercise caution when removing bad labels from brush. Careless removal can result in brisals being pull out which may leave the labeler inoperable until the brush is replaced!

TROUBLESHOOTING:

PROBLEM

- Product jams at brush area
- Bubbles in label
- Label edge curling
- Wipedown inadequate

WHAT TO DO

- Increase brush spacing.
- Decrease labeling speed
- Decrease product delay
- Decrease brush spacing.

ITEM	QTY	PART NO.	DESCRIPTION	PARENT ITEM
1	2	362186-000	COLLAR, 3/8 IN. ID ONE-PIECE CLAMP	10228-013
2	2	A21264-026	CROSS ARM	10228-013
3	2	A21693-301	IMPRESSOR MOUNTING BLOCK	10228-013
4	3	A23463-100	BRUSH HOLDER	10228-013

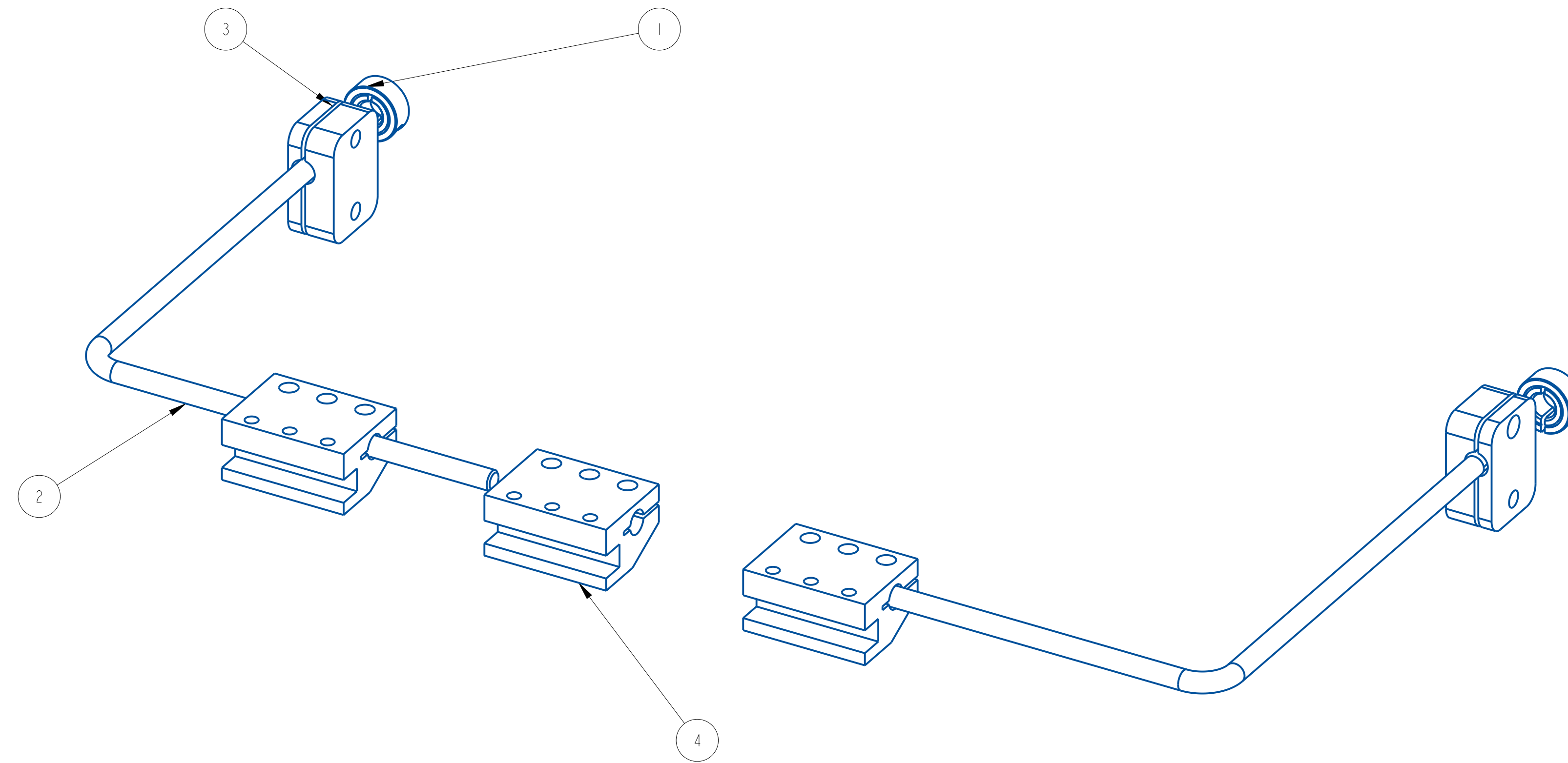

REV	DATE	DESCRIPTION	BY
A	Jan-14-26	NEW DRAWING	TAZ

THIS IS A PRO-ENGINEER DOCUMENT AND MAY NOT BE MODIFIED MANUALLY

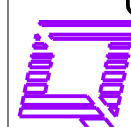
UNLESS OTHERWISE SPECIFIED DIMENSIONAL TOLERANCE .X ± .1 .XX ± .01 .XXX ± .005 ANGLES ± 30° SURFACE FINISH 125 BREAK ALL EDGES .005/ .015 CORNER RADIUS .010/ .030 ALL ANGLES ARE 90°	 7670 JENTHER DRIVE MENTOR, OHIO 44060 (440) 602-4700	SCALE: 3/4
		DATE: Jan-14-26
		DRW BY: TAZ
		CHK BY:
12" WIDE IMPRESSOR ASSEMBLY		APPR BY:
MAT'L	10228-013	10228-013

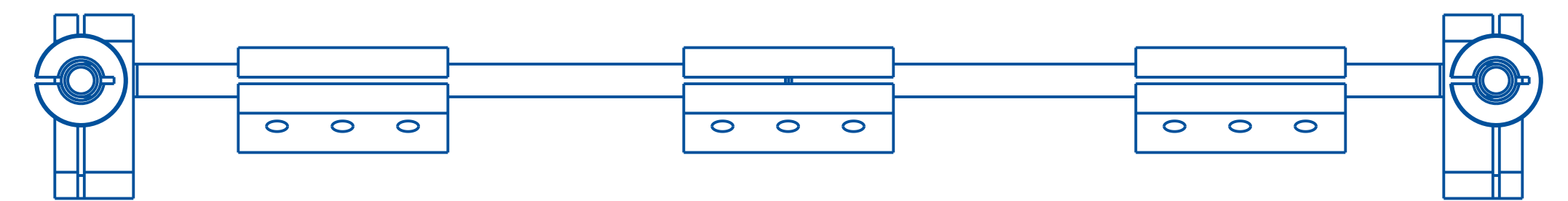
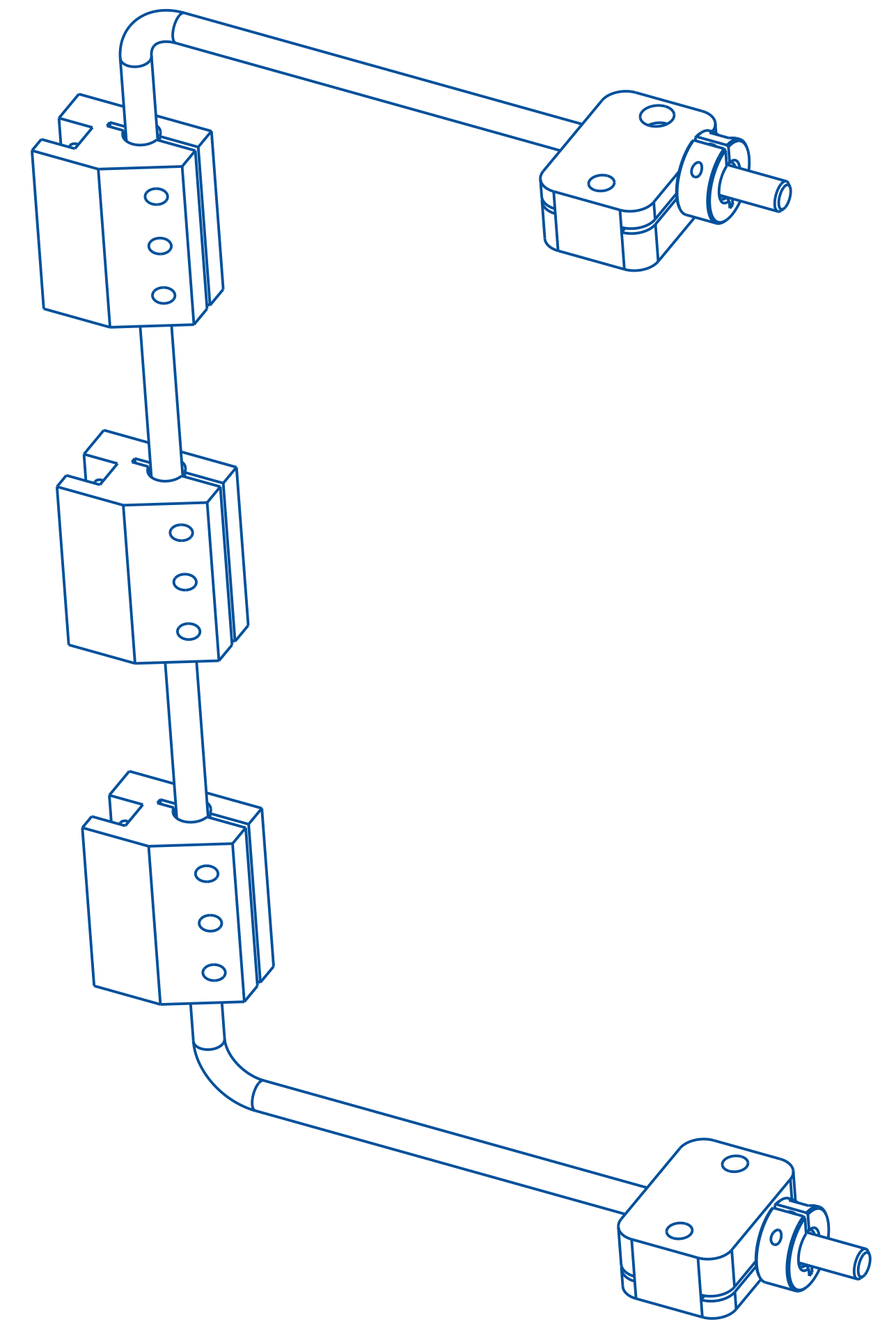
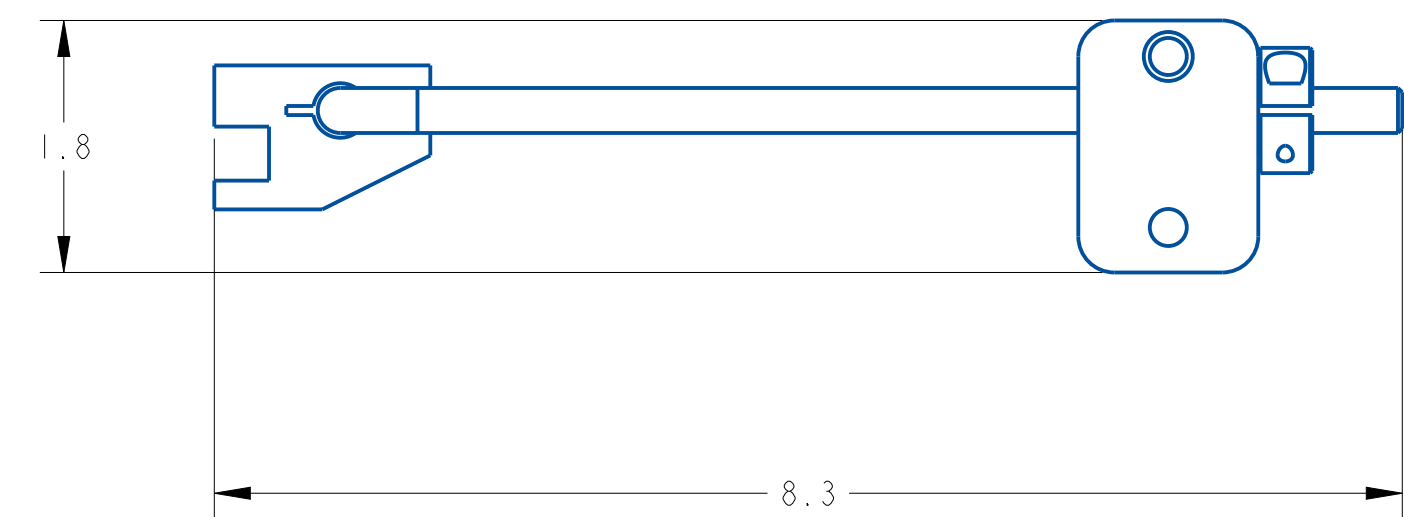
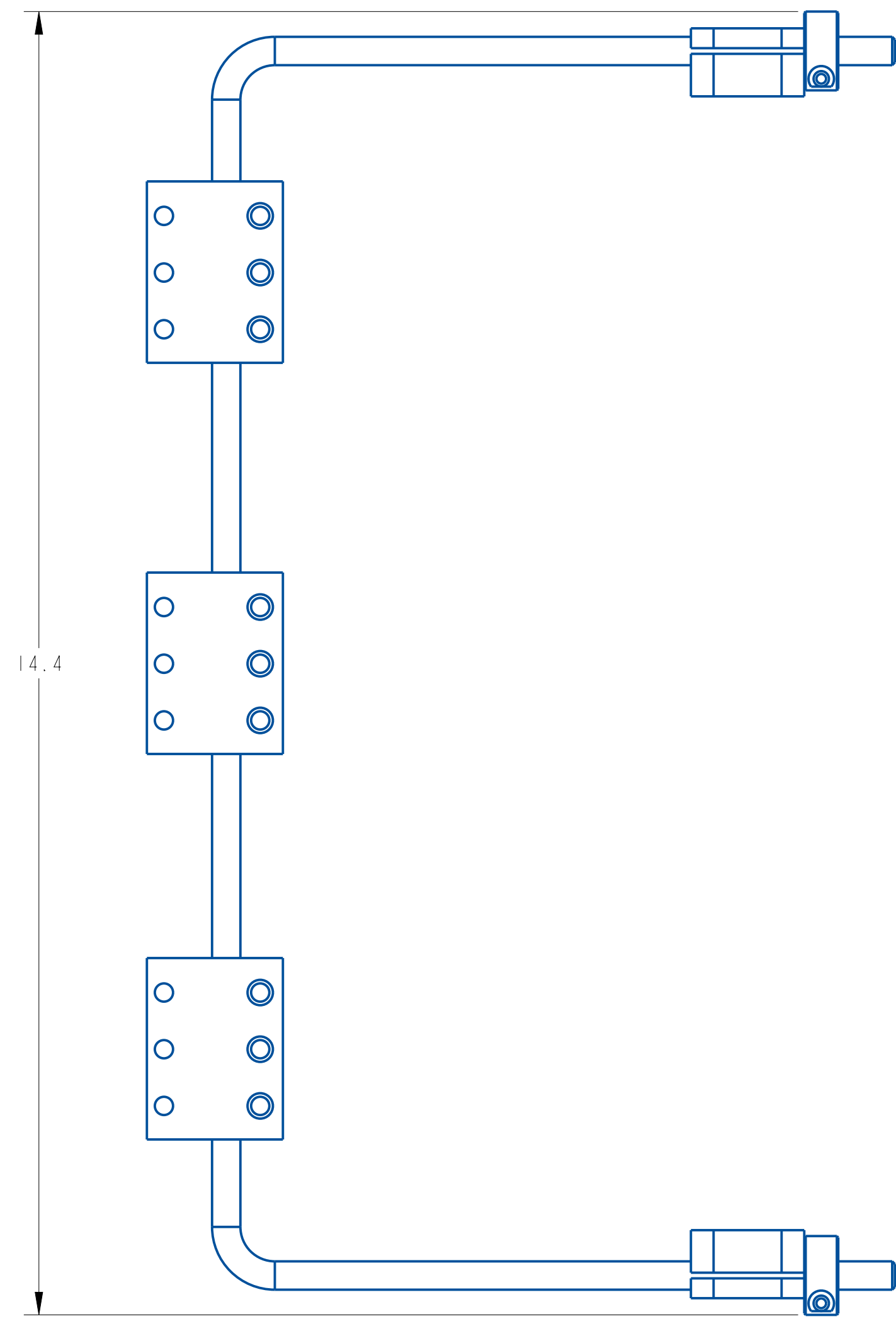

REV	DATE	DESCRIPTION	BY
A	Jan-14-26	NEW DRAWING	TAZ

THIS IS A PRO-ENGINEER DOCUMENT AND MAY NOT BE MODIFIED MANUALLY

UNLESS OTHERWISE SPECIFIED DIMENSIONAL TOLERANCE	.X ± .1 .XX ± .01 .XXX ± .005 ANGLES ± .30°	SCALE: 3/4 DATE: Jan-14-26 DRW BY: TAZ APPR BY:
SURFACE FINISH 125 BREAK ALL EDGES .005/.015 CORNER RADIUS .010/.030 ALL ANGLES ARE 90°		QUADREL LABELING SYSTEMS 7670 JENTHER DRIVE MENTOR, OHIO 44060 (440) 602-4700
12" WIDE IMPRESSOR ASSEMBLY		MAT'L 10228-013 10228-013

ASSEMBLY TITLE: Q60 DRIVE

DRAWING NO.: 7" Web D21693-002

GENERAL FUNCTION:

- The drive roll pulls the liner through the entire labeling head. As the liner is pulled over the peel edge, the label dispenses.
- The spring-loaded pinch roll squeezes the liner against the drive roll to provide positive drive.
- The primary roll is the pull or drive roll as shown. The knurl roll provides a constant pressure against the pull roll.

SET UP AND ADJUSTMENTS:

- When threading the labeling head, use the pinch roll lever to release the pinch roll from the drive roll.
- Use the spring plunger adjustment screws to adjust the contact pressure between the knurl and pull rollers.
- The pressure should be adjusted as tight as necessary to prevent a loose liner, while still allowing full rotation of the pressure release arm.

MAINTENANCE:

- Clean all parts that may have acquired label or glue residue

TROUBLESHOOTING:

PROBLEM

- Meter pulley rubbing against side plate
- Web slips
- Drive roll not rotating when stepping motor rotates
- Pinch roll not providing enough pressure against drive roll
- Drive roll unevenly worn causing tracking problem

WHAT TO DO

- Center pulley on motor shaft and tighten two (2) set screws in pulley.
- Drive roller not closed. Turn drive roll arm to closed position.
- Replace timing belt from motor to drive roll
- Replace pinch roll spring
- Increase tension on drive roll by adjusting spring loaded locking pins.
- Replace drive roll

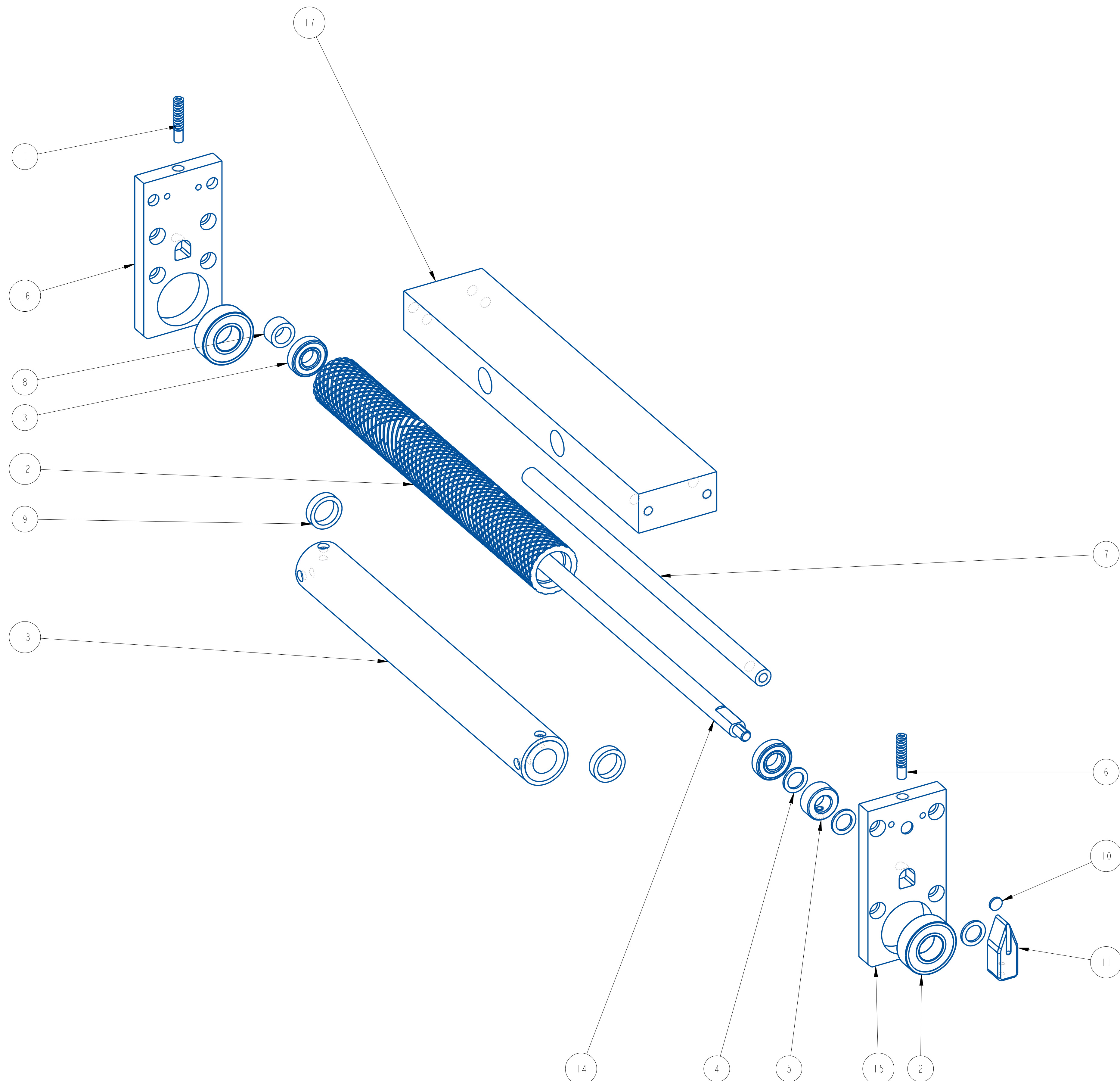

ITEM	QTY	PART NO.	DESCRIPTION	PARENT ITEM
1	2	00301-17	SPRING, .275 x .052 x .94	22620D-LHH-12
2	2	111052-000	BEARING	22620D-LHH-12
3	2	111072-000	BEARING, BALL	22620D-LHH-12
4	3	151004-000	BEARING, THRUST WASHER	22620D-LHH-12
5	1	362161-000	COLLAR, SETSCREW, 1/2 IN. ID	22620D-LHH-12
6	2	A20567-000	WHITE NYLON SLUG	22620D-LHH-12
7	1	A20929-012	PINCH POINT GUARD ROD 12" WEB	22620D-LHH-12
8	1	A23751-000	SPACER	22620D-LHH-12
9	2	A23752-000	SPACER	22620D-LHH-12
10	1	A25249-000	INDEX DOT	22620D-LHH-12
11	1	A25250-000	IND KNOB	22620D-LHH-12
12	1	B20126-002	KNURLED ROLL	22620D-LHH-12
13	1	B20342-012	PULL ROLL, 10"	22620D-LHH-12
14	1	B20346-014	KNURLED ROLL SHAFT, 12"	22620D-LHH-12
15	1	B21614-000	YOKE OUTSIDE PLATE	22620D-LHH-12
16	1	B21615-000	YOKE INSIDE PLATE	22620D-LHH-12
17	1	B21616-113	YOKE FILLER BAR	22620D-LHH-12

NOT SHOWN:
A23827-008 PULL ROLL WEDGE, 12"

REV	DATE	DESCRIPTION	BY
A	Mar-07-25	NEW DRAWING	TAZ

THIS IS A PRO-ENGINEER DOCUMENT AND MAY NOT BE MODIFIED MANUALLY

QUADREL LABELING SYSTEMS
7670 JENTHER DRIVE
MENTOR, OHIO 44060
(440) 602-4700

SCALE: 5/8
DATE: Mar-07-25
DRW BY: TAZ
CHK BY: 03/25/2025-SEM
APPR BY:

12" DRIVE ROLL ASSEMBLY

MAT'L: _____

22620D-LHH-12

UNLESS OTHERWISE SPECIFIED
DIMENSIONAL TOLERANCE
X ± .1
XX ± .01
XXX ± .005
ANGLES ± .30°
SURFACE FINISH 125
BREAK ALL EDGES .005/ .015
CORNER RADIUS .010/ .030
ALL ANGLES ARE 90°

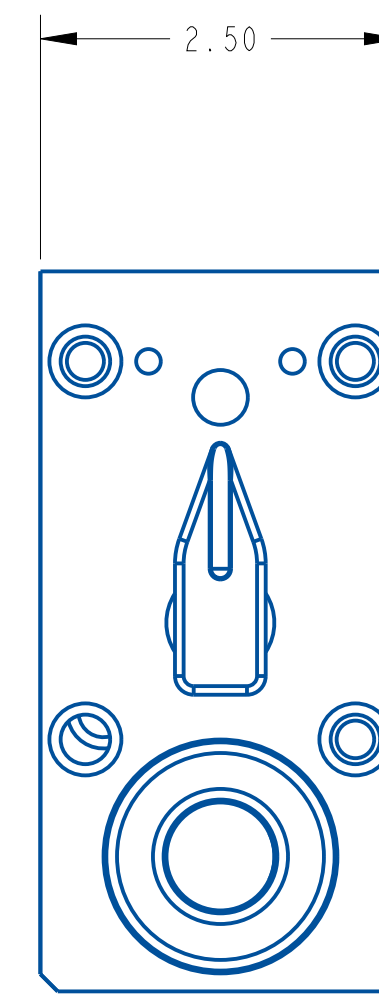
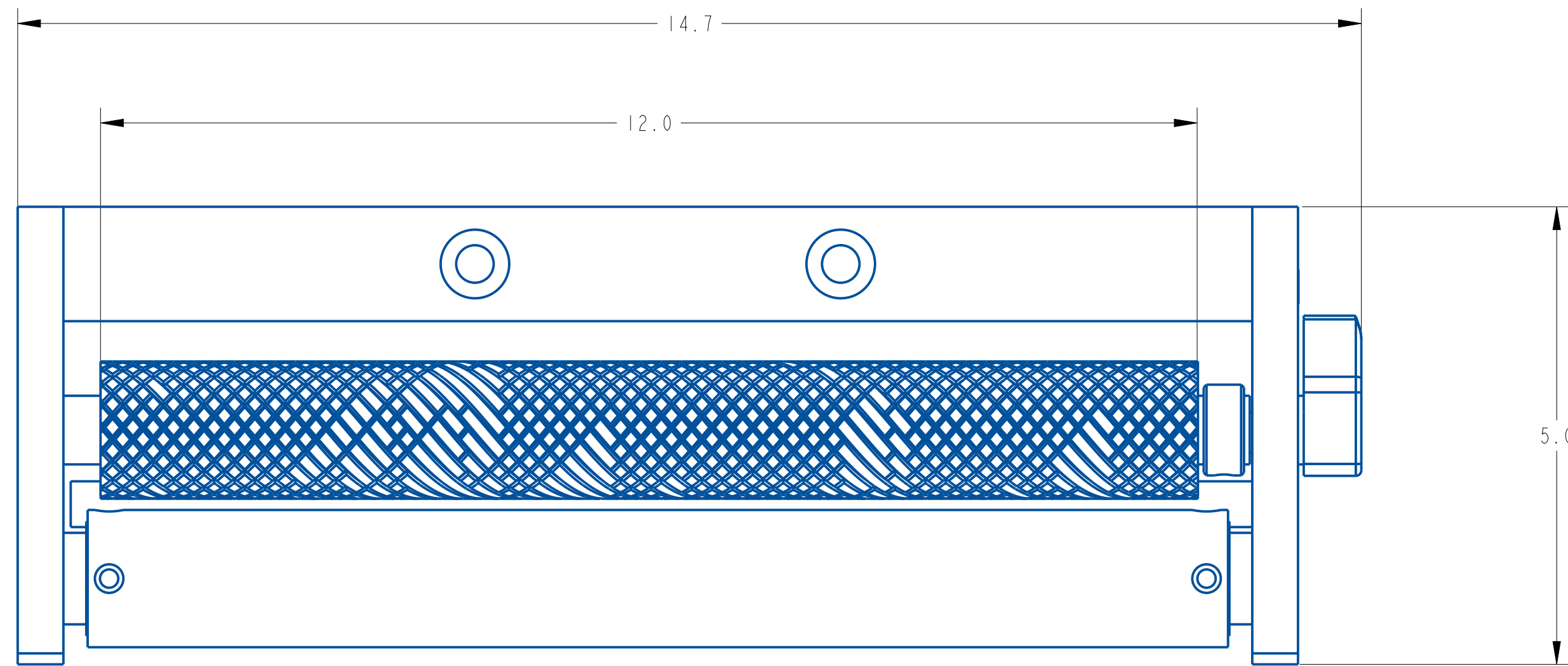
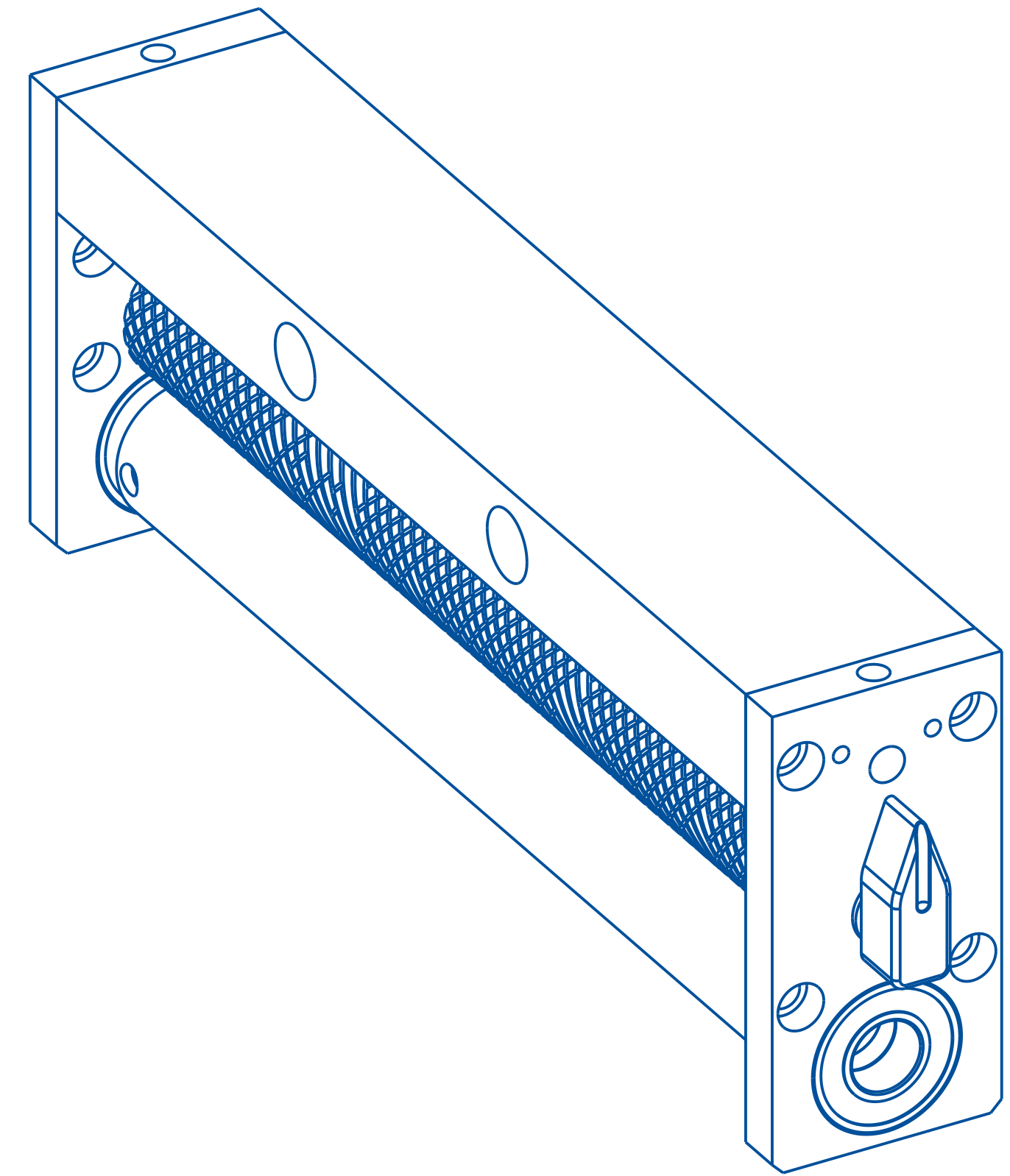

REV	DATE	DESCRIPTION	BY
A	Mar-07-25	NEW DRAWING	TAZ

THIS IS A PRO-ENGINEER DOCUMENT AND MAY NOT BE MODIFIED MANUALLY

UNLESS OTHERWISE SPECIFIED
 DIMENSIONAL TOLERANCE
 .XX ± .01
 .XXX ± .005
 ANGLES ± 30°

SURFACE FINISH 125
 BREAK ALL EDGES .005/ .015
 CORNER RADIUS .010/ .030
 ALL ANGLES ARE 90°

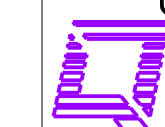

QUADREL LABELING SYSTEMS
 7670 JENTHER DRIVE
 MENTOR, OHIO 44060
 (440) 602-4700

SCALE: 3/4
 DATE: Mar-07-25
 DRW BY: TAZ
 CHK BY: 03/25/2025-SEM
 APPR BY:

12" DRIVE ROLL ASSEMBLY

MAT'L	QTY	DESCRIPTION
		22620D-LHH-12
		22620D-LHH-12

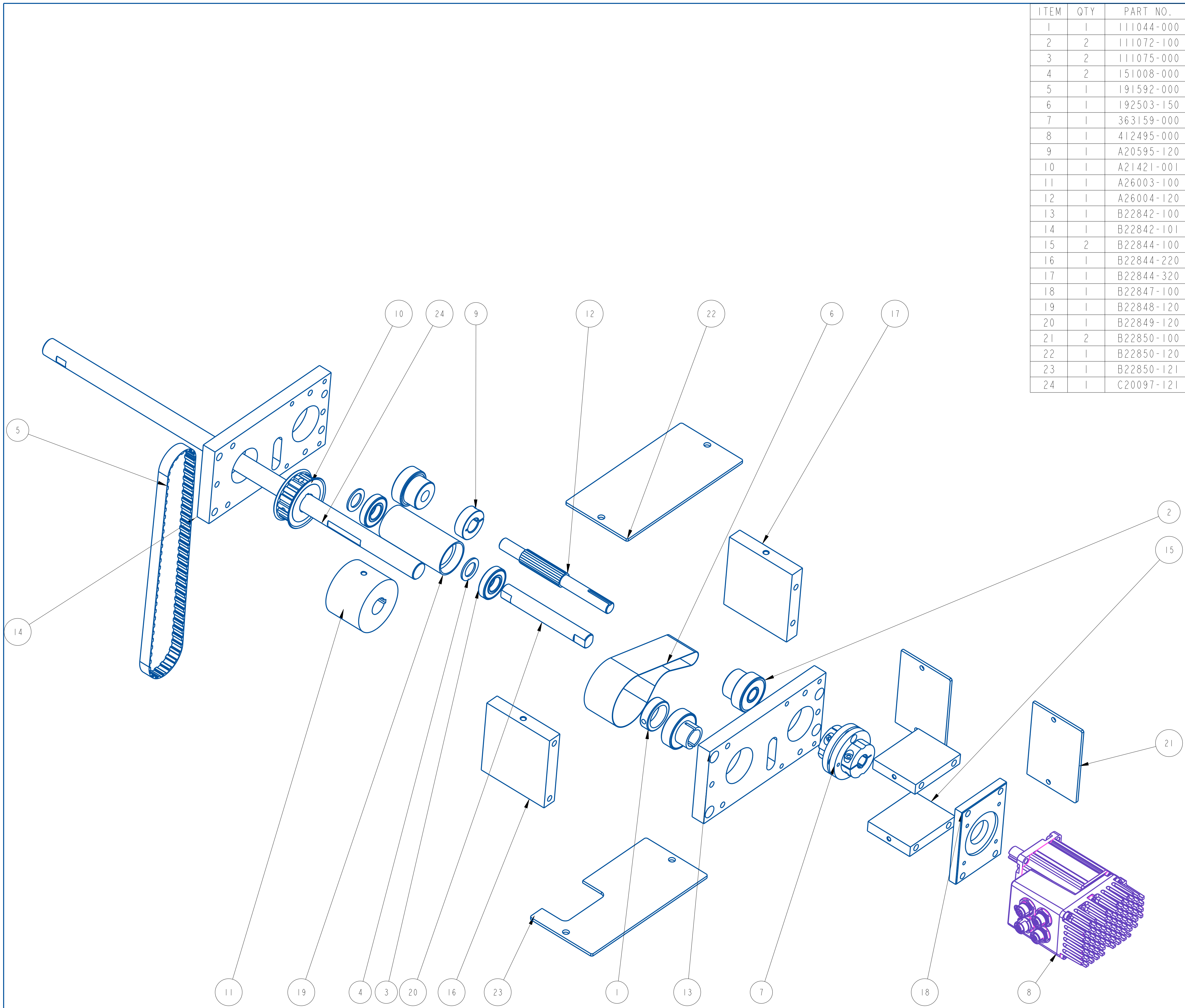

ITEM	QTY	PART NO.	DESCRIPTION	PARENT ITEM
1	1	111044-000	BEARING, 3/4 ID CLAMP TYPE	23125D-012LH
2	2	111072-100	BEARING BALL, LOCKING COLLAR .5" IDx1.574" OD	23125D-012LH
3	2	111075-000	BEARING, BALL	23125D-012LH
4	2	151008-000	BEARING, THRUST WASHER	23125D-012LH
5	1	191592-000	BELT, TIMING, 1/2P	23125D-012LH
6	1	192503-150	TIMING BELT	23125D-012LH
7	1	363159-000	SERVO COUPLING-1/2"BORE & KEY 14 MM BORE	23125D-012LH
8	1	412495-000	SERVO MOTOR/DRIVE, 60mm	23125D-012LH
9	1	A20595-120	COLLAR REWORK	23125D-012LH
10	1	A21421-001	DRIVE PULLEY (MODIFIED)	23125D-012LH
11	1	A26003-100	DRIVE PULLEY	23125D-012LH
12	1	A26004-120	SERVO MOTOR PULLEY	23125D-012LH
13	1	B22842-100	BEARING PLATE	23125D-012LH
14	1	B22842-101	BEARING PLATE	23125D-012LH
15	2	B22844-100	SPACER	23125D-012LH
16	1	B22844-220	SPACER	23125D-012LH
17	1	B22844-320	SPACER	23125D-012LH
18	1	B22847-100	MOTOR MOUNTING PLATE	23125D-012LH
19	1	B22848-120	TENSION ROLLER	23125D-012LH
20	1	B22849-120	TENSIONER SHAFT	23125D-012LH
21	2	B22850-100	COVER	23125D-012LH
22	1	B22850-120	COVER	23125D-012LH
23	1	B22850-121	COVER	23125D-012LH
24	1	C20097-121	PULL ROLL DRIVE SHAFT	23125D-012LH

A		Jan-08-26	NEW DRAWING	TAZ
REV	DATE	DESCRIPTION	BY	

THIS IS A PRO-ENGINEER DOCUMENT AND MAY NOT BE MODIFIED MANUALLY

QUADREL LABELING SYSTEMS
 7670 JENTHER DRIVE
 MENTOR, OHIO 44060
 (440) 602-4700

SCALE: 1/2
 DATE: Jan-08-26
 DRW BY: TAZ
 CHK BY:
 APPR BY:

Q60 12" SERVO DRIVE & REWIND, LHH

MAT'L 23125D-012LH 23125D-012LH

UNLESS OTHERWISE SPECIFIED
 DIMENSIONAL TOLERANCE
 .XX ± .01
 .XXX ± .005
 ANGLES ± 30°
 SURFACE FINISH 125
 BREAK ALL EDGES .005/.015
 CORNER RADIUS .010/.030
 ALL ANGLES ARE 90°

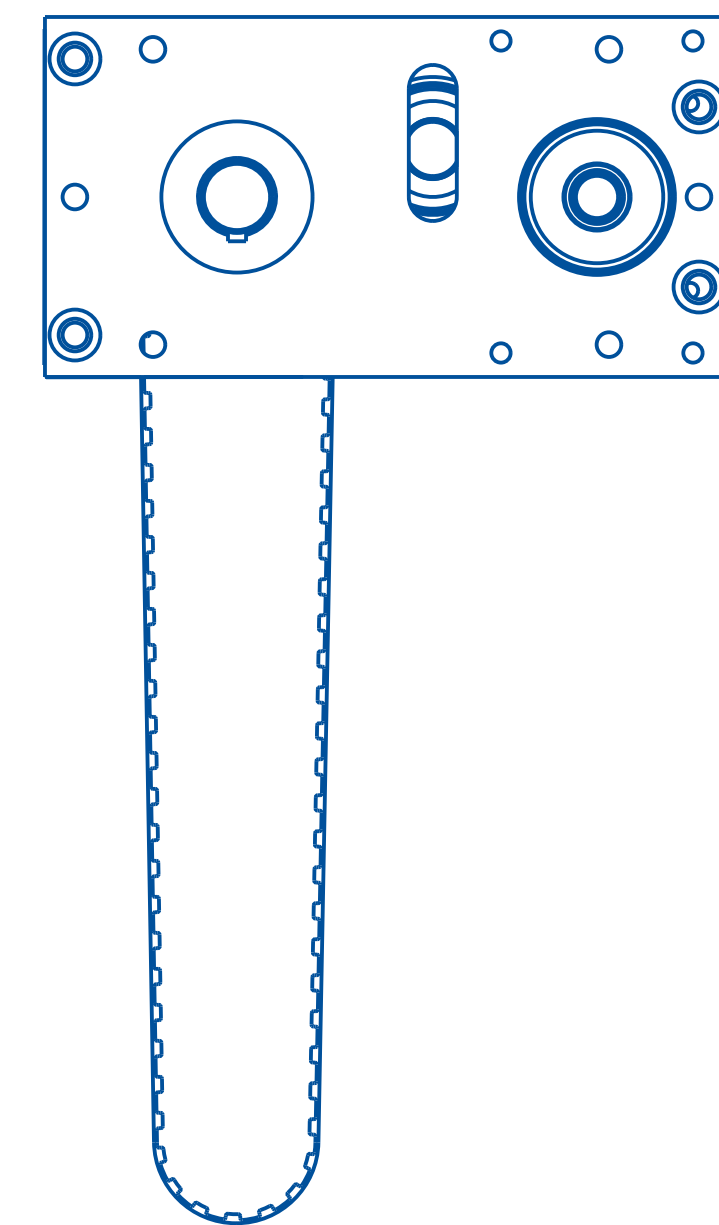
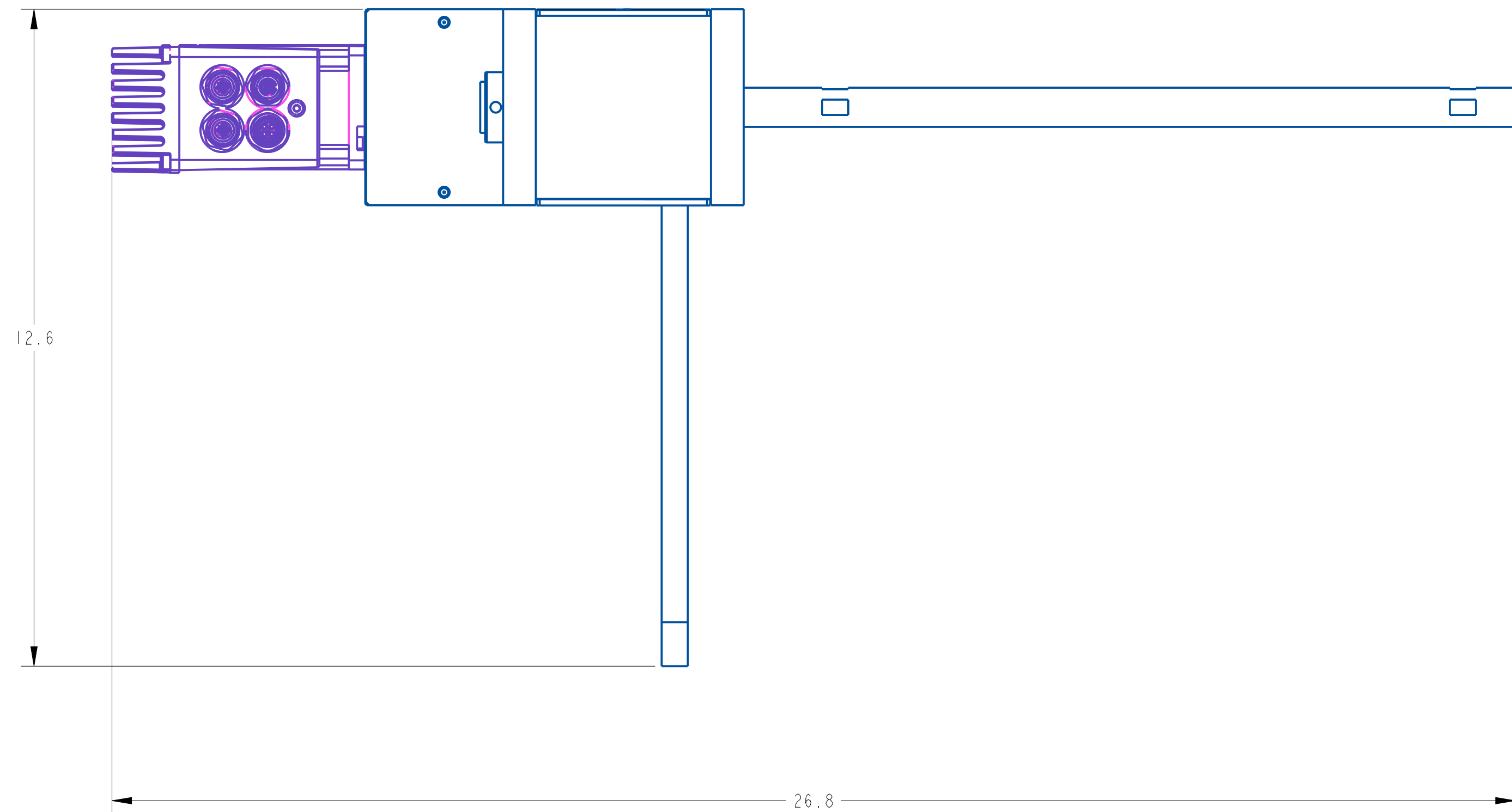
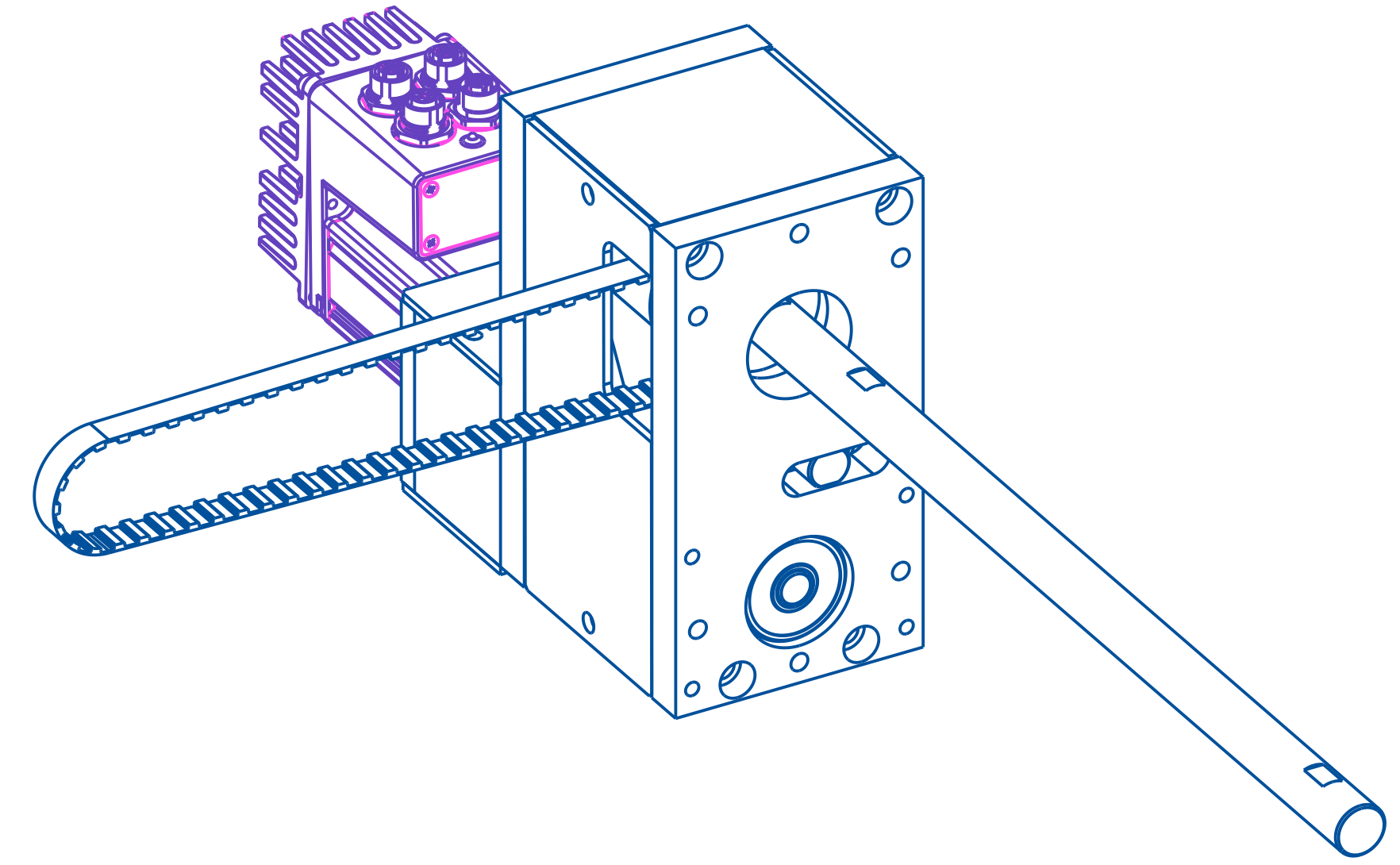
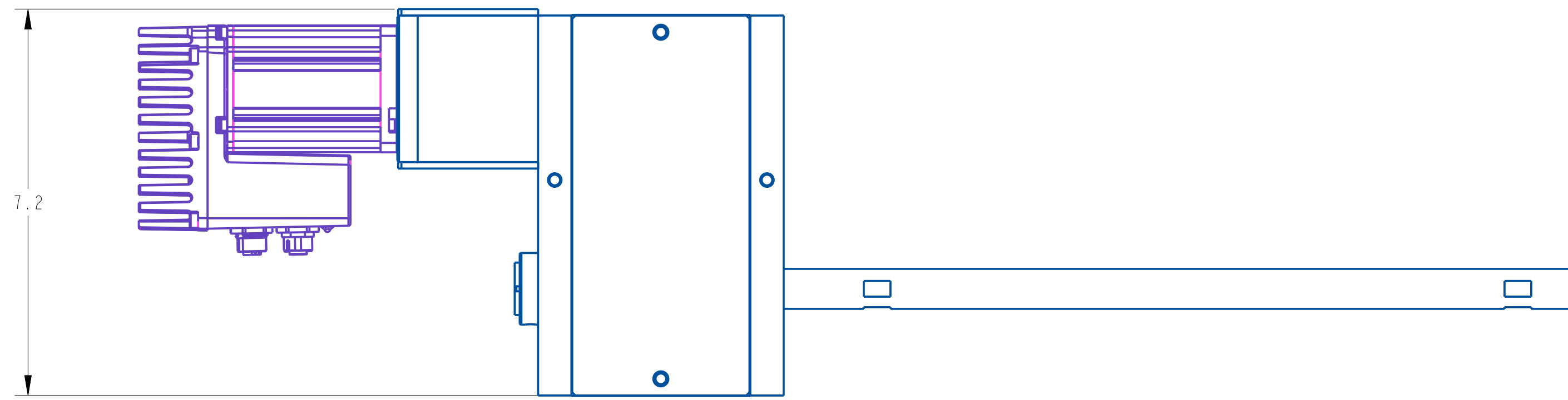

REV	DATE	DESCRIPTION	BY
A	Jan-08-26	NEW DRAWING	TAZ

THIS IS A PRO-ENGINEER DOCUMENT AND MAY NOT BE MODIFIED MANUALLY

UNLESS OTHERWISE SPECIFIED
 DIMENSIONAL TOLERANCE
 .x ± .1
 .xx ± .01
 .xxx ± .005
 ANGLES ± .30°
 SURFACE FINISH 125
 BREAK ALL EDGES .005/.015
 CORNER RADIUS .010/.030
 ALL ANGLES ARE 90°

QUADREL LABELING SYSTEMS
 7670 JENTHER DRIVE
 MENTOR, OHIO 44060
 (440) 602-4700

SCALE: 1/2
 DATE: Jan-08-26
 DRW BY: TAZ
 CHK BY:
 APPR BY:

Q60 12" SERVO DRIVE & REWIND, LHH
 MAT'L 23125D-012LH 23125D-012LH

Servo Belt Removal & Installation

Remove the clear cover on the side of the coupling of the servo motor. Then loosen the 4 5/16-18 socket heads holding the motor mounting plate to the spacer blocks. (Shown in image on the right)

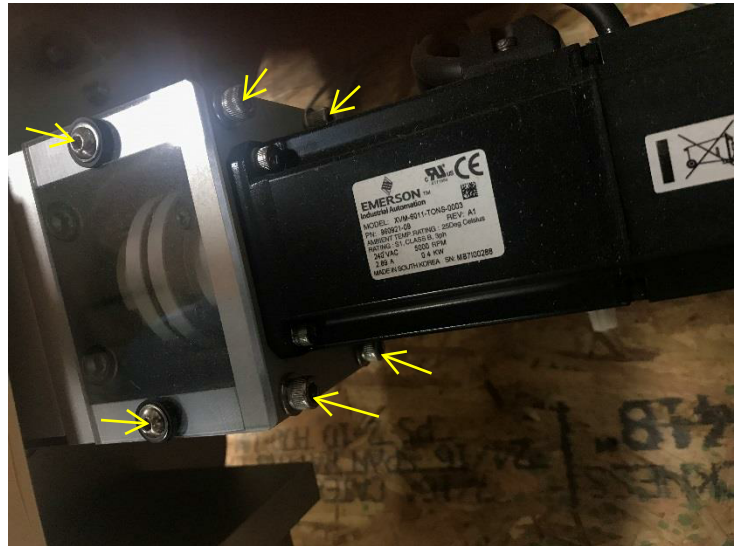

Loosen the 2 bolts on the coupling. Then remove the motor and coupling assembly. (Shown in image on the left)

Loosen the tension on the servo belt by removing loosening the 2 jam nuts on the set screws shown and removing the set screws. (Shown in image on the right)





Loosen set screw in the collar on the end of the drive shaft. Then remove the collar. (Shown in image on the left)

Remove the 4 5/16-18 socket head bolts that hold the bottom plate to the spacer blocks. Then remove the two button head screws holding the lexan cover on and remove cover. (Shown in image on the right)

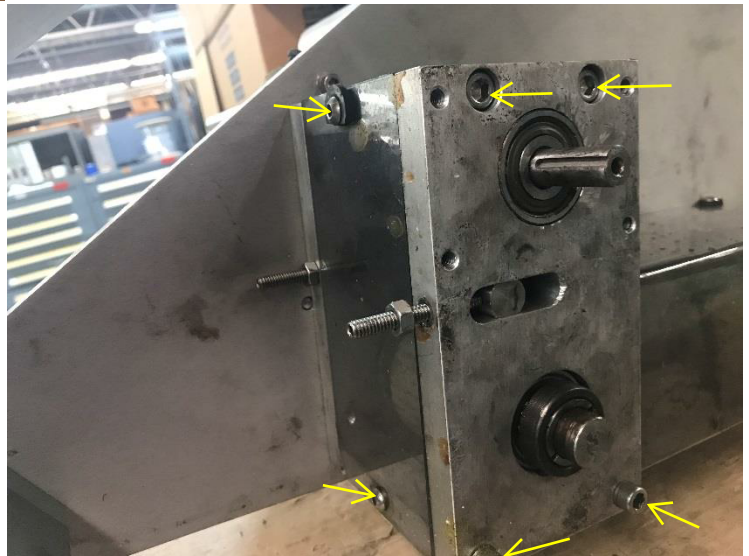

Remove the set screw on the eccentric collar then spin the collar to loosen from shaft. (Shown in image on the left)

Once the bolts are removed, remove the bottom plate. This may take some prying and finessing, be careful to not bend the plate, shafts, or ruin the bearings during the removal of the plate. Once removed clean the plate and bearings. (Shown in image on the right & bottom)



If Equipped

Remove the cover over the rewind kinetrol and other side of the servo belt. (Shown in image on the left)

Remove the tensioner, belt and smaller diameter shaft with the pulley teeth on it. (Shown in image on the right)



Once removed clean all surfaces shafts bearing and check the rewind belt for cracks or uneven wear. You can use a scotch brite pad the clean up the shafts and ect. (Shown in image on the left)

Check the lock collar on the shaft with the pulley grooves ensure the collar is tight and the stack up is correct. The washer goes on top of the collar and shall be flush with the end of the pulley grooves as shown in the image below. Slide the collar over the end of the shaft as shown. This stack up is extremely important.



Ensure your belt is riding properly on the kinetrol pulley. The belt should be running in the middle of the pulley of as close to centered as you can get. Spin the kinetrol and ensure the belt is tracking well. (Shown below)

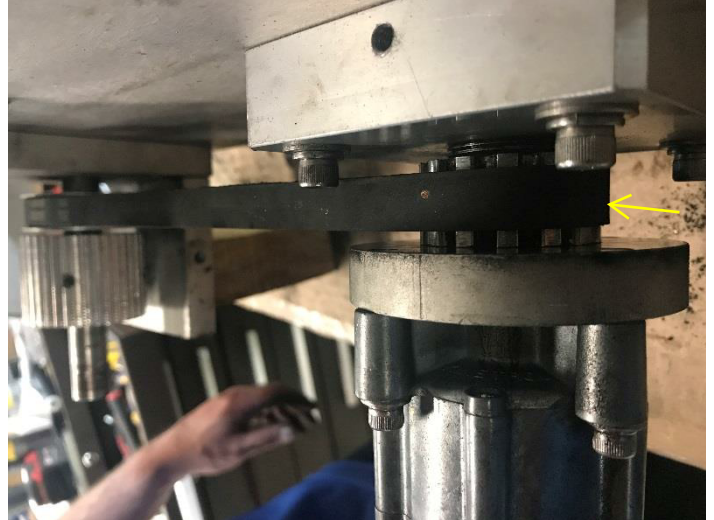

To adjust this rotate the pulley until you see the set screw. Loosen the set screws and slide the pulley accordingly. Slide the larger pulley down or up as well these pulleys should be together. (Shown in image on the right)



After you have cleaned everything up, checked the rewind belt and properly checked alignment of the pulleys. It is now time to re-assemble. Start by putting the belt in then the tensioner. Ensure the idler has the oil lite washers installed on the top and bottom of the idler. (Shown in the image to the left)

NOTE Blue Loctite is recommended on all fasteners.

Place the eccentric collar over the smaller diameter shaft and slide the bottom servo plate on. Ensure the tensioner is positioned properly in the slot on the bottom plate with the oil lite washer in place. Fasten the plate to the spacer blocks. Once fastened rotate the eccentric collar to lock it into place make sure it is tight this is very important. Lock into place with set screw. (Shown in image below)

NOTE Blue Loctite is recommended on all fasteners.

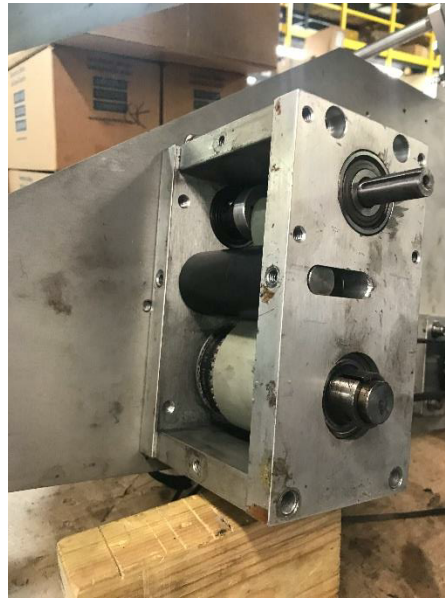
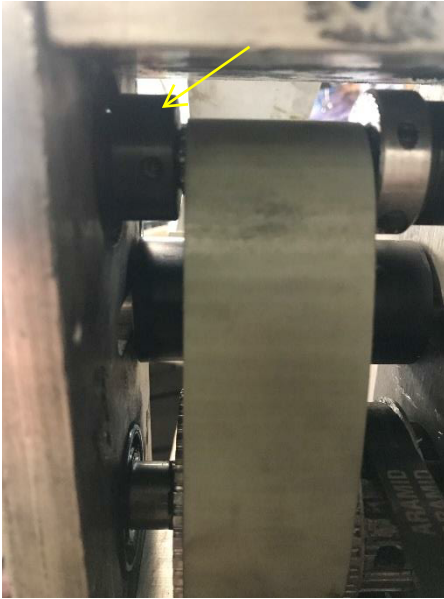

Thread in the set screws evenly to set tension on the belt the belt should not be too tight if you reach around the back you can push against the belt as you tighten it. This is more of a touch setting you do not want the belt to be solid to the touch more like 1/8th - 1/4th inch of travel when you push on the belt. If it is too loose it can skip teeth. When the tension is set lock into place using the jam nuts. (Shown in image below)

NOTE Do NOT loctite set screws for the tensioner.

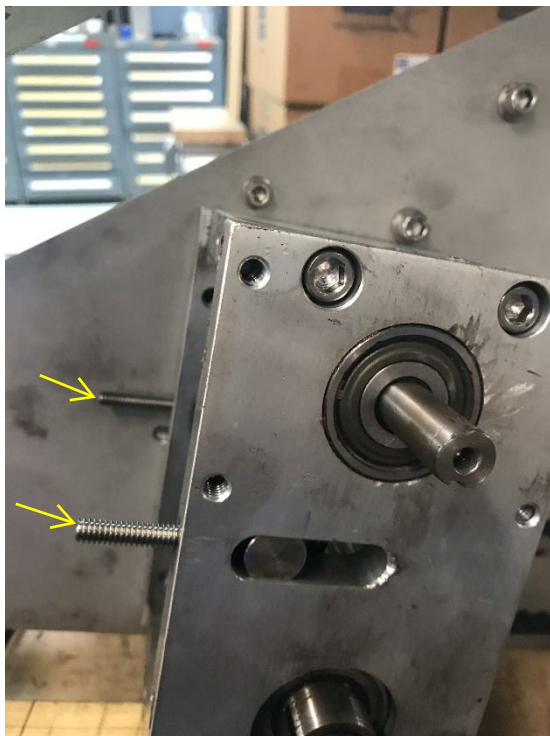

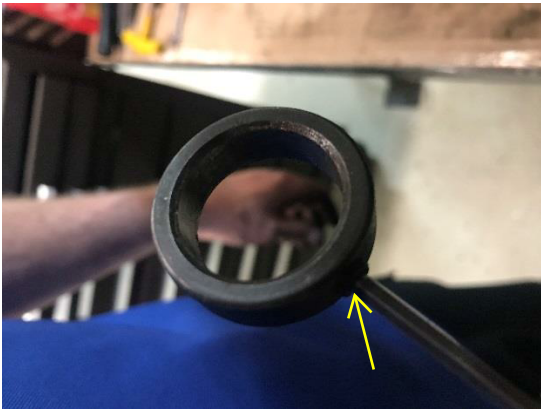

Fasten the collar to the end of the larger diameter shaft as shown.

NOTE Blue Loctite is recommended on all fasteners.

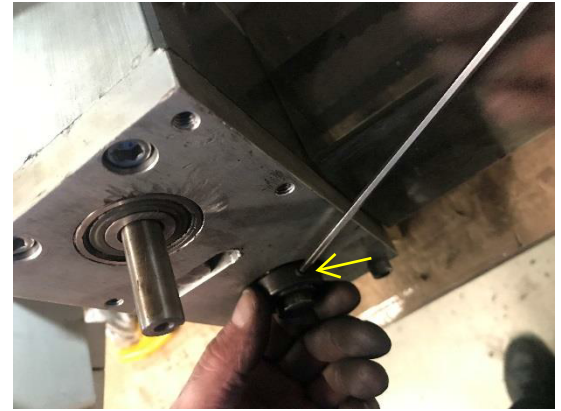

Place the lexan covers on the 2 sides of the servo belt assembly and the cover over the rewind kinetrol assembly. Make sure the fasteners has blue Loctite and rubber grommets. (Shown in image on the left)

Place the servo motor coupling over the end of the smaller diameter shaft. Fasten the motor mounting assembly to the bottom plate using blue Loctite. Align the coupling centered between the shafts so the coupling has enough to fasten to on each of the shafts. Fasten the coupling to the shafts. Mount the lexan covers make sure the fasteners has blue Loctite and rubber grommets. (Shown in image on the right)

NOTE Blue Loctite is recommended on all fasteners.



ASSEMBLY TITLE: Q60 REWIND ASSEMBLY

DRAWING NO.: 7" Web D22280-000 & D22392-000

GENERAL FUNCTION:

- The rewind drum rolls up the liner
- The rewind pin, when pulled out, allows the liner to be released from the rewind drum.
- The rewind flange supports and guides the liner.
- The friction clutch allows for slippage to accommodate for varying speeds between the drive roll and rewind drum.
- The adjusting knob controls the torque adjustment of the drum.

SET UP AND ADJUSTMENTS:

- Position the rewind flange slightly below the web path and lock with the set screw in the hub.
- When threading liner to the rewind, place the liner between the drum and pin.
- Tighten adjusting knob just enough to allow the rewind drum to keep up with the drive roll.

NOTE: Excessive tightening will cause the web to be wound very tight, causing difficulty in removal and possible step motor stall.

MAINTENANCE:

- Clean all parts that have acquired label or glue residue
- Replace friction disc when worn out.

TROUBLESHOOTING:

PROBLEM

WHAT TO DO

- | | |
|--|--|
| - Rewind drum not rotating when stepping motor rotates | - Replace timing belt from motor to rewind |
| - Rewind drum not keeping up with drive roll | - Tighten adjusting knob |
| - Web winding too tight on hub | - Loosen adjusting knob |
| - Grinding in rewind hub | - Replace friction disc by removing knob and sliding off rewind drum |

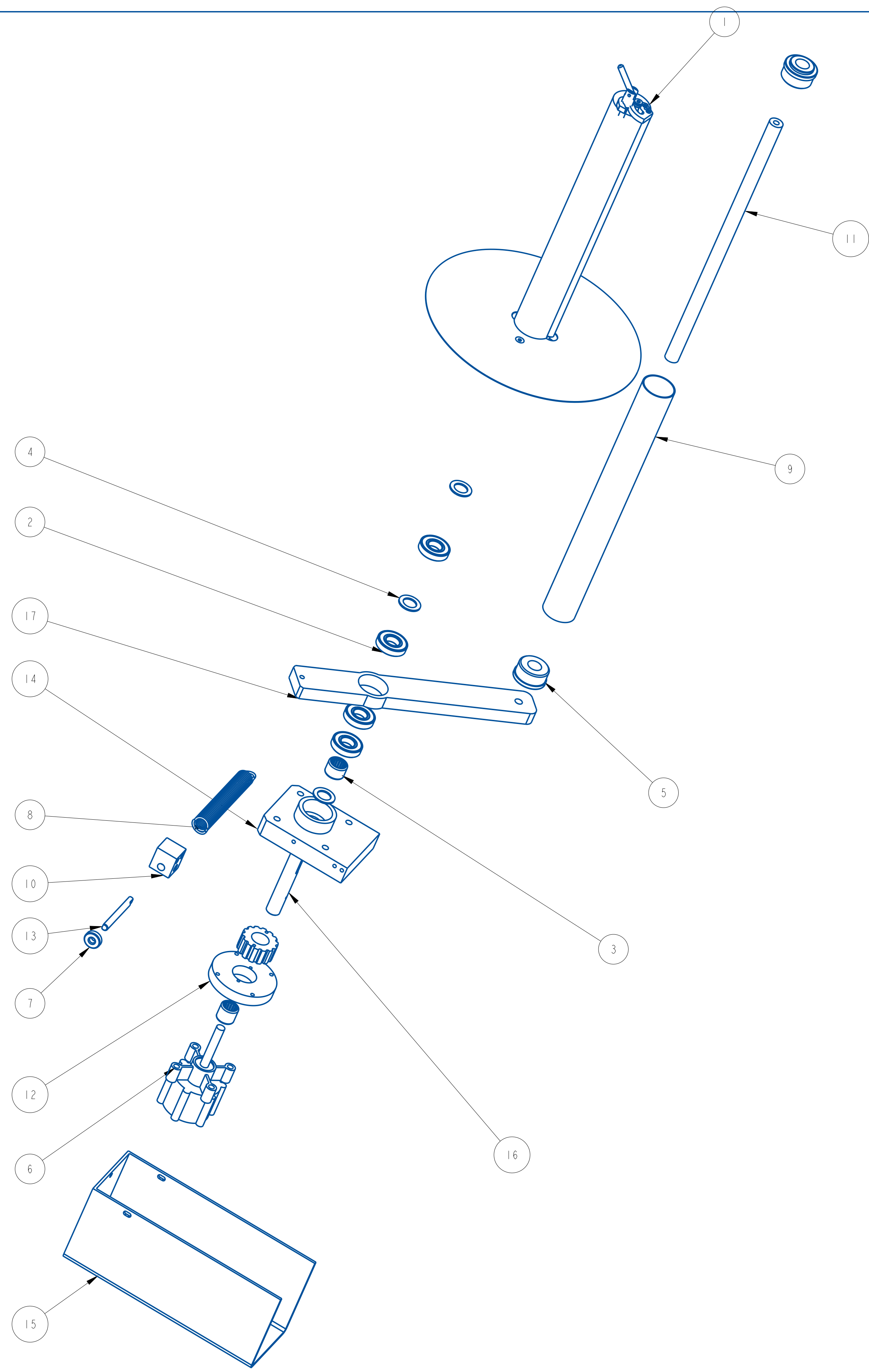

ITEM	QTY	PART NO.	DESCRIPTION	PARENT ITEM
1	1	22189-113	COLLAPSIBLE REWIND	22524R-003
2	4	111075-000	BEARING, BALL	22524R-003
3	1	121067-000	BEARING, NEEDLE	22524R-003
4	3	151008-000	BEARING, THRUST WASHER	22524R-003
5	2	181062-000	BEARING, ROLL END	22524R-003
6	1	361302-000	DASHPOT	22524R-003
7	1	801601-000	CHECK NUT	22524R-003
8	1	811216-000	EXTENSION SPRING	22524R-003
9	1	A21259-113	IDLER ROLLER	22524R-003
10	1	A21479-000	SPRING ADJUSTMENT BLOCK	22524R-003
11	1	A21618-013	IDLER SHAFT	22524R-003
12	1	A22120-000	REWIND PULLEY ASSEMBLY	22524R-003
13	1	A23131-000	STUD	22524R-003
14	1	B20004-009	REWIND BEARING PLATE	22524R-003
15	1	B20005-127	GUARD	22524R-003
16	1	B20747-000	DASHPOT REWIND SHAFT	22524R-003
17	1	C20894-010	REWIND DANCER ARM	22524R-003

REV	DATE	DESCRIPTION	BY
A	Mar-06-25	NEW DRAWING	TAZ

THIS IS A PRO-ENGINEER DOCUMENT AND MAY NOT BE MODIFIED MANUALLY

UNLESS OTHERWISE SPECIFIED
DIMENSIONAL TOLERANCE

.x ± .1
 .xx ± .01
 .xxx ± .005
 ANGLES ± .30°

SURFACE FINISH 125
BREAK ALL EDGES .005/ .015
CORNER RADIUS .010/ .030
ALL ANGLES ARE 90°

QUADREL LABELING SYSTEMS
 7670 JENTHER DRIVE
 MENTOR, OHIO 44060
 (440) 602-4700

SCALE: 11/32
 DATE: Mar-06-25
 DRW BY: TAZ
 CHK BY:
 APPR BY:

Q60 REWIND & DANCER ASSEMBLY w/KINETROL, 12"

MAT'L 22524R-003 22524R-003

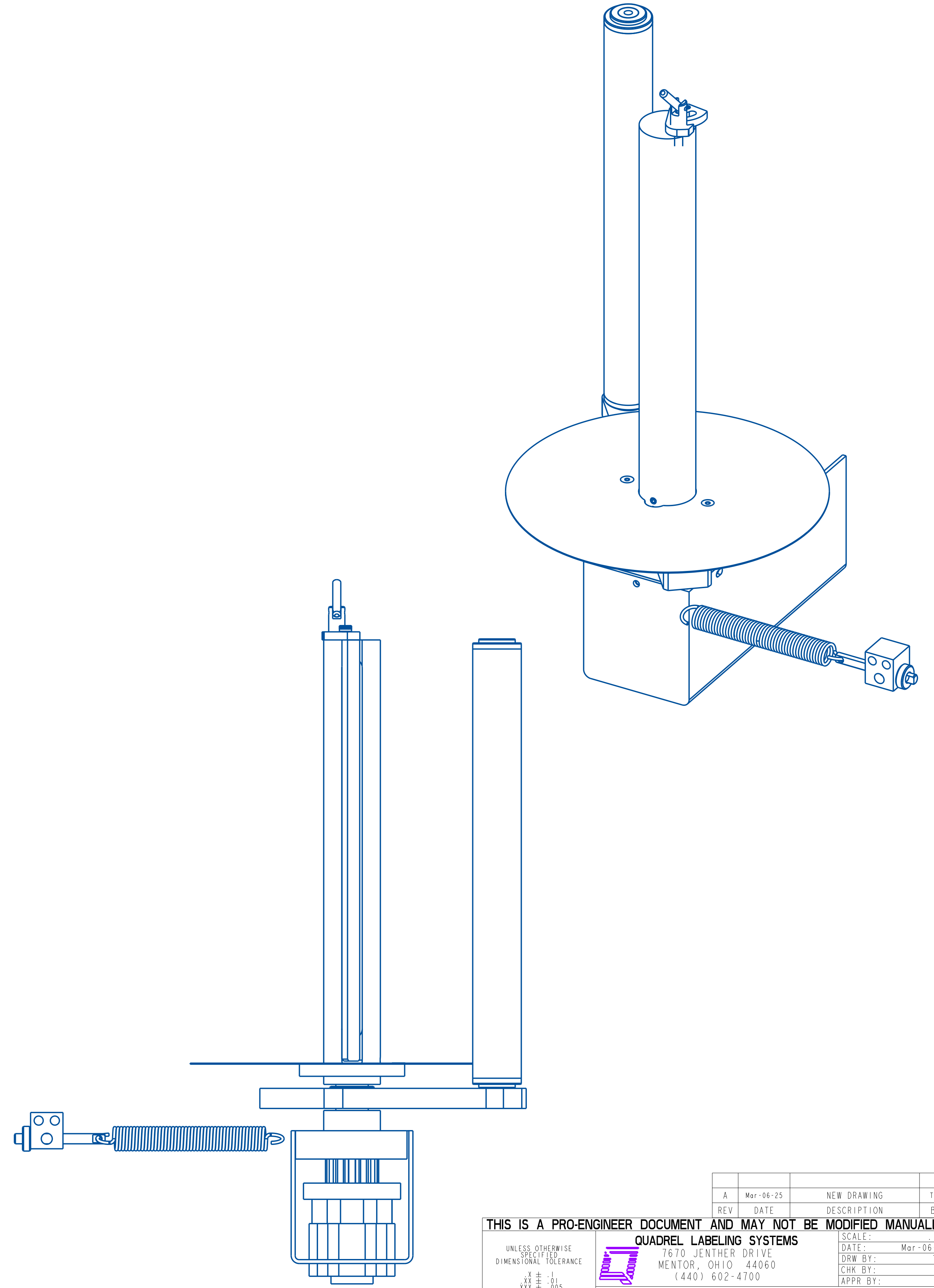
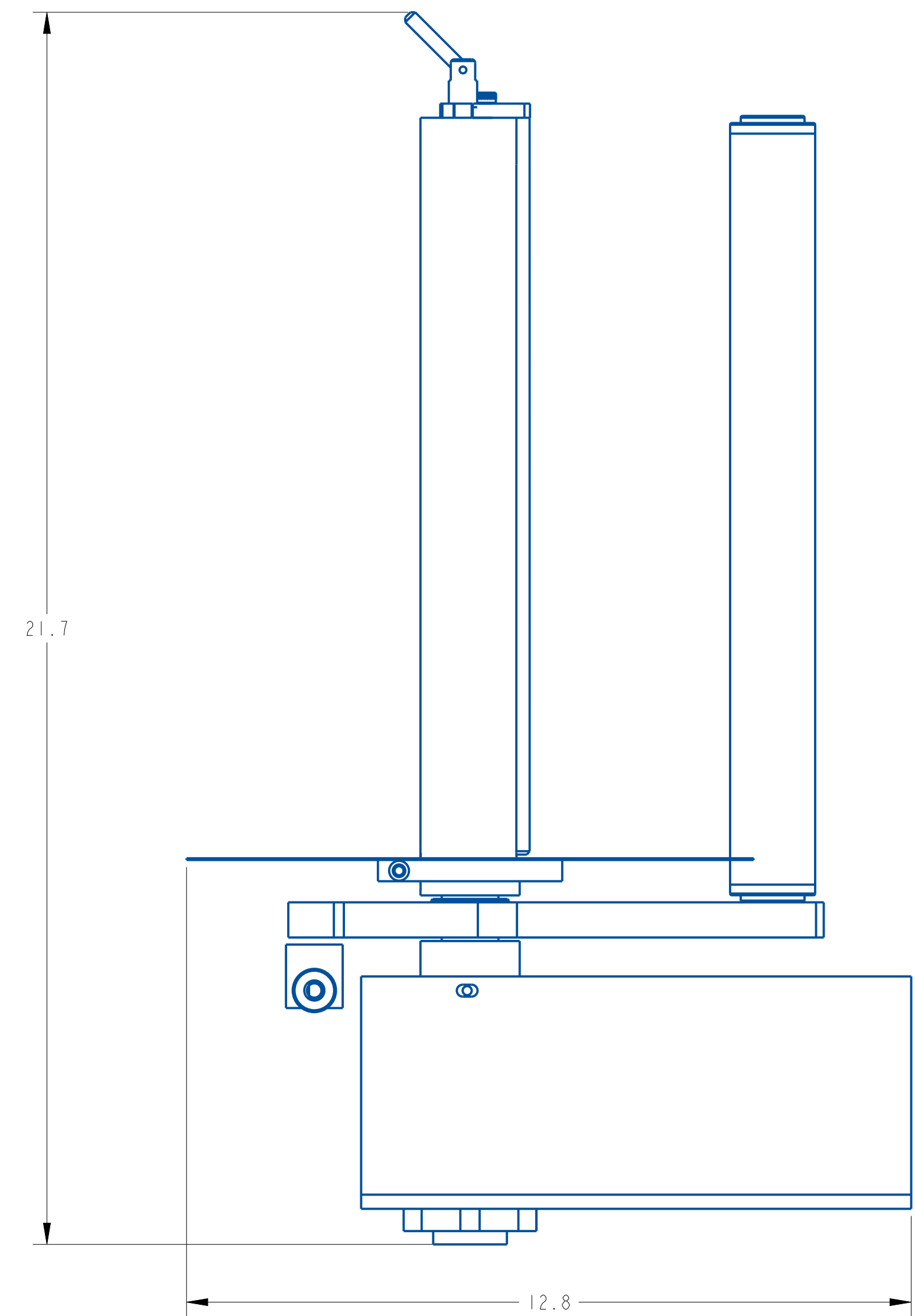
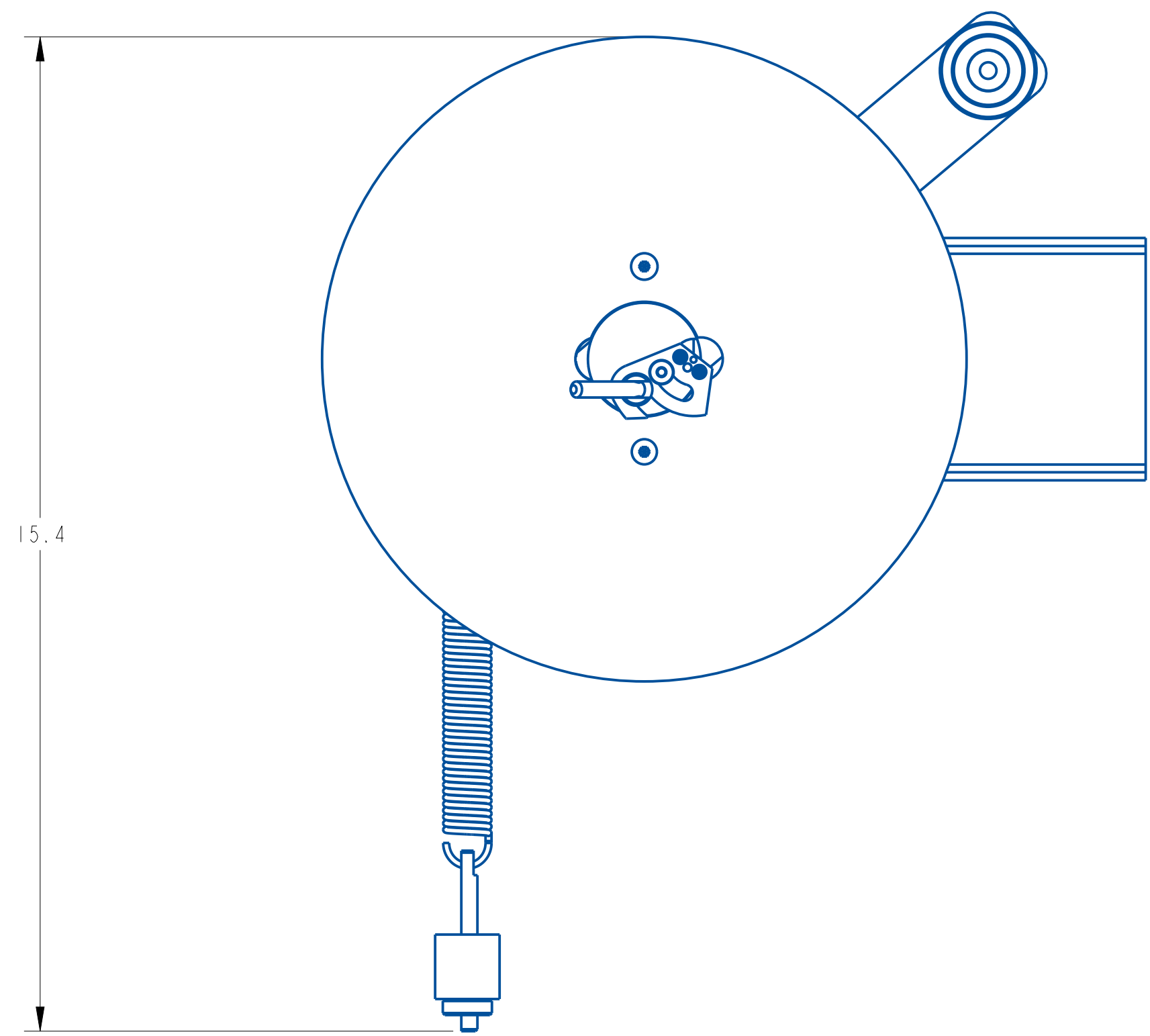

SHEET 2 OF 2

THIS IS A PRO-ENGINEER DOCUMENT AND MAY NOT BE MODIFIED MANUALLY

UNLESS OTHERWISE SPECIFIED	QUADREL LABELING SYSTEMS	SCALE: .1/2
DIMENSIONAL TOLERANCE	7670 JENTHER DRIVE	DATE: Mar-06-25
.X ± .01	MENTOR, OHIO 44060	DRW BY: TAZ
.XX ± .005	(440) 602-4700	CHK BY:
ANGLES ± 30°		APPR BY:
SURFACE FINISH 125	Q60 REWIND & DANCER ASSEMBLY w/KINETROL, 12"	MAT'L
BREAK ALL EDGES .005/0.15		22524R-003
CORNER RADIUS .010/0.30		22524R-003
ALL ANGLES ARE 90°		

A	Mar-06-25	NEW DRAWING	TAZ
REV	DATE	DESCRIPTION	BY

ITEM	QTY	PART NO.	DESCRIPTION	PARENT ITEM
1	1	22597-000	COLLAPSIBLE REWIND LOCKING HANDLE	22189-113
2	1	841145-000	1/4 X 1/2 LG. SHOULDER BOLT	22189-113
3	1	A21226-000	REWIND FLANGE HUB COLLAR	22189-113
4	1	A22085-001	COLLAPSIBLE REWIND REEL	22189-113
5	1	B22103-113	10" COLLAPSIBLE REWIND DRUM	22189-113
6	1	B22141-013	SHAFT ASSEMBLY	22189-113
7	2	CSEE253	10-32 X 3/8 LG. FLAT HEAD	22189-113
8	1	SYE103	1/4-20 X 5/8 LG. SET SCREW	22189-113

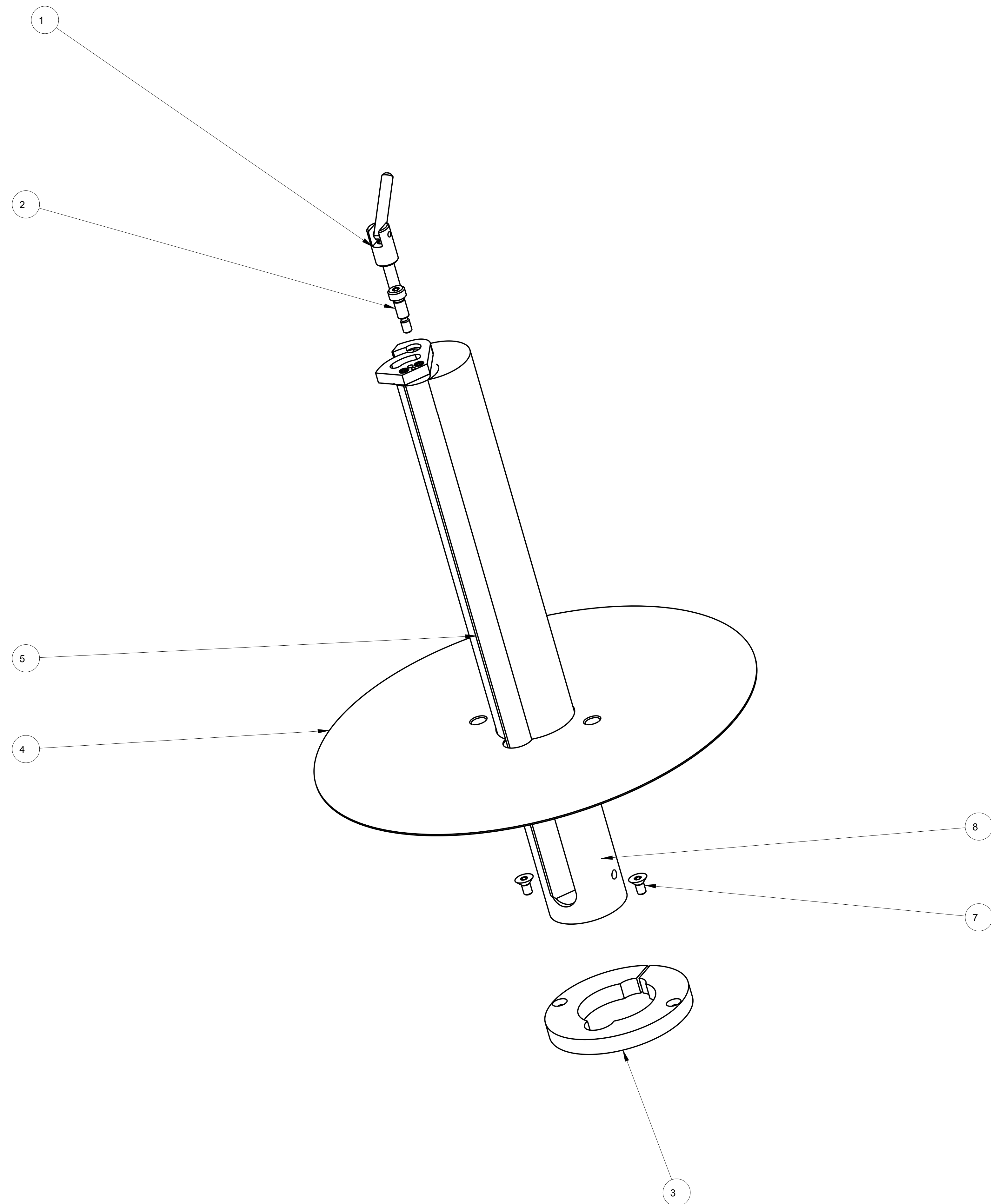

REV	DATE	DESCRIPTION	BY
A	Jun-06-17	NEW DRAWING	CRT

THIS IS A PRO-ENGINEER DOCUMENT AND MAY NOT BE MODIFIED MANUALLY

UNLESS OTHERWISE SPECIFIED DIMENSIONAL TOLERANCE	QUADREL LABELING SYSTEMS 7670 JENTHER DRIVE MENTOR, OHIO 44060 (440) 602-4700	SCALE: 3/4 DATE: Jun-06-17 DRAWN BY: CRT
.X± .1 .XX± .01 .XXX± .005 ANGLES ± 30°	COLLAPSIBLE REWIND	
SURFACE FINISH: 125 BREAK ALL EDGES: .005/.015 CORNER RADIUS: .010/.030	MAT'L	22189-113
		22189-113

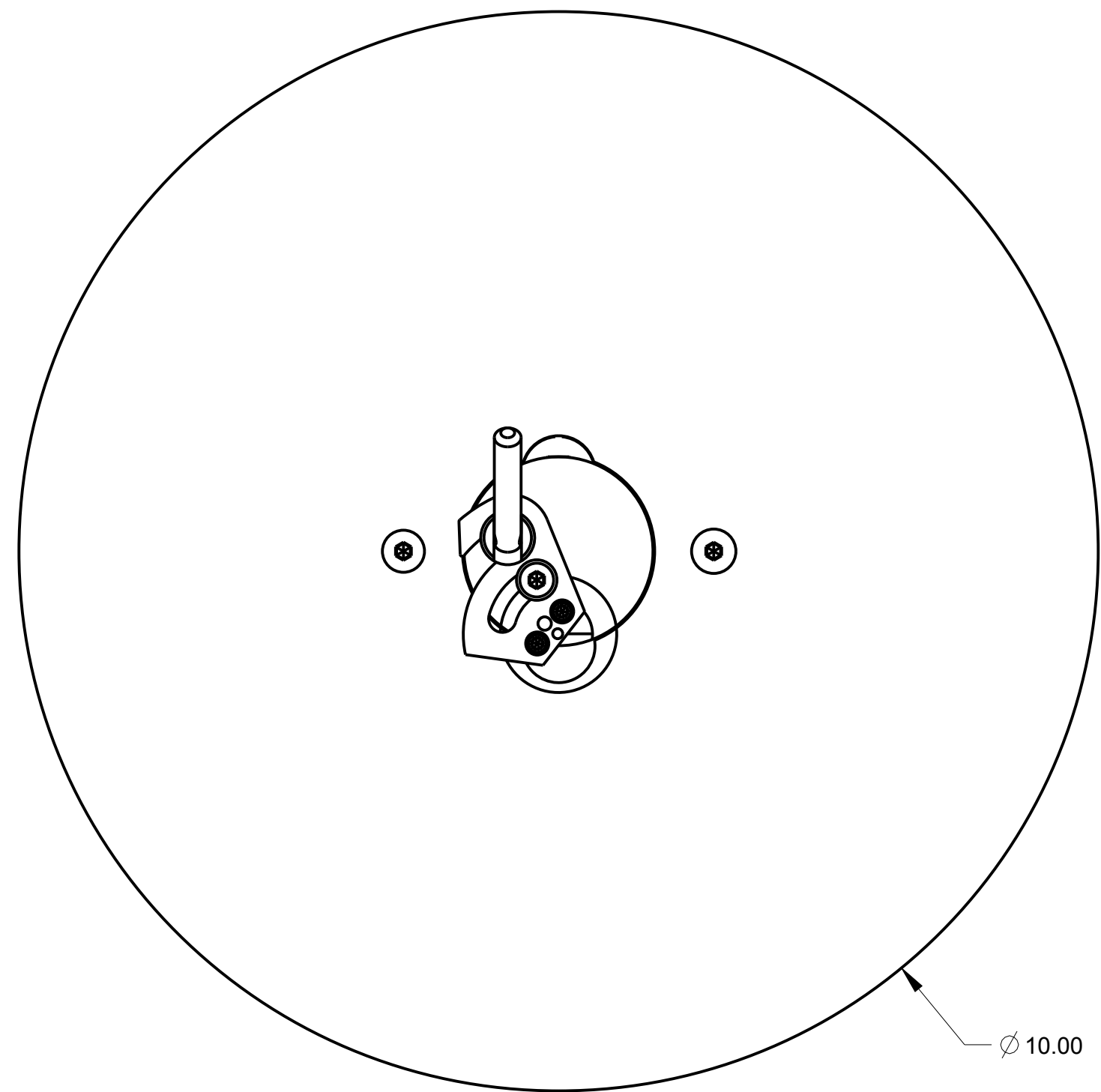

Ø 10.00

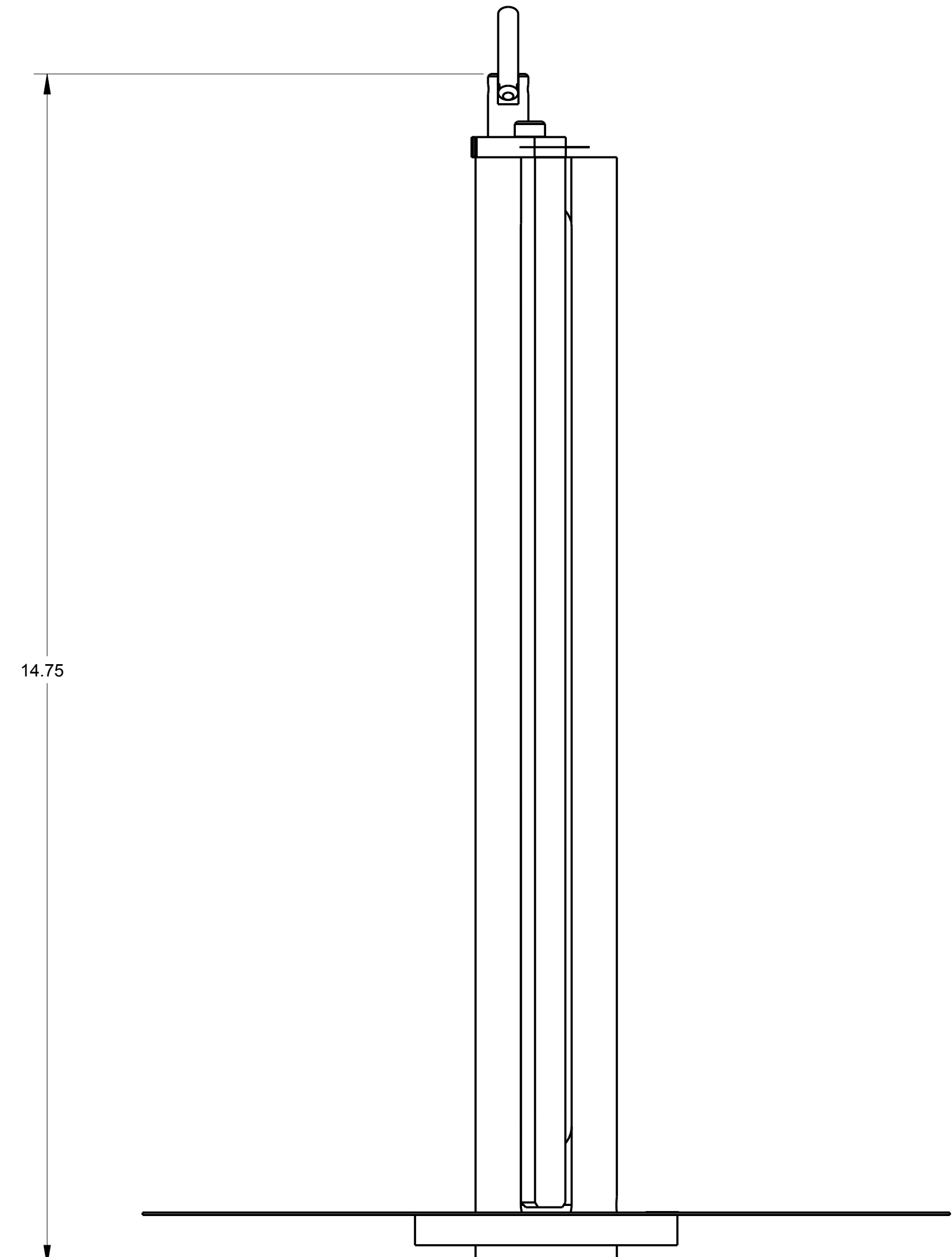

14.75

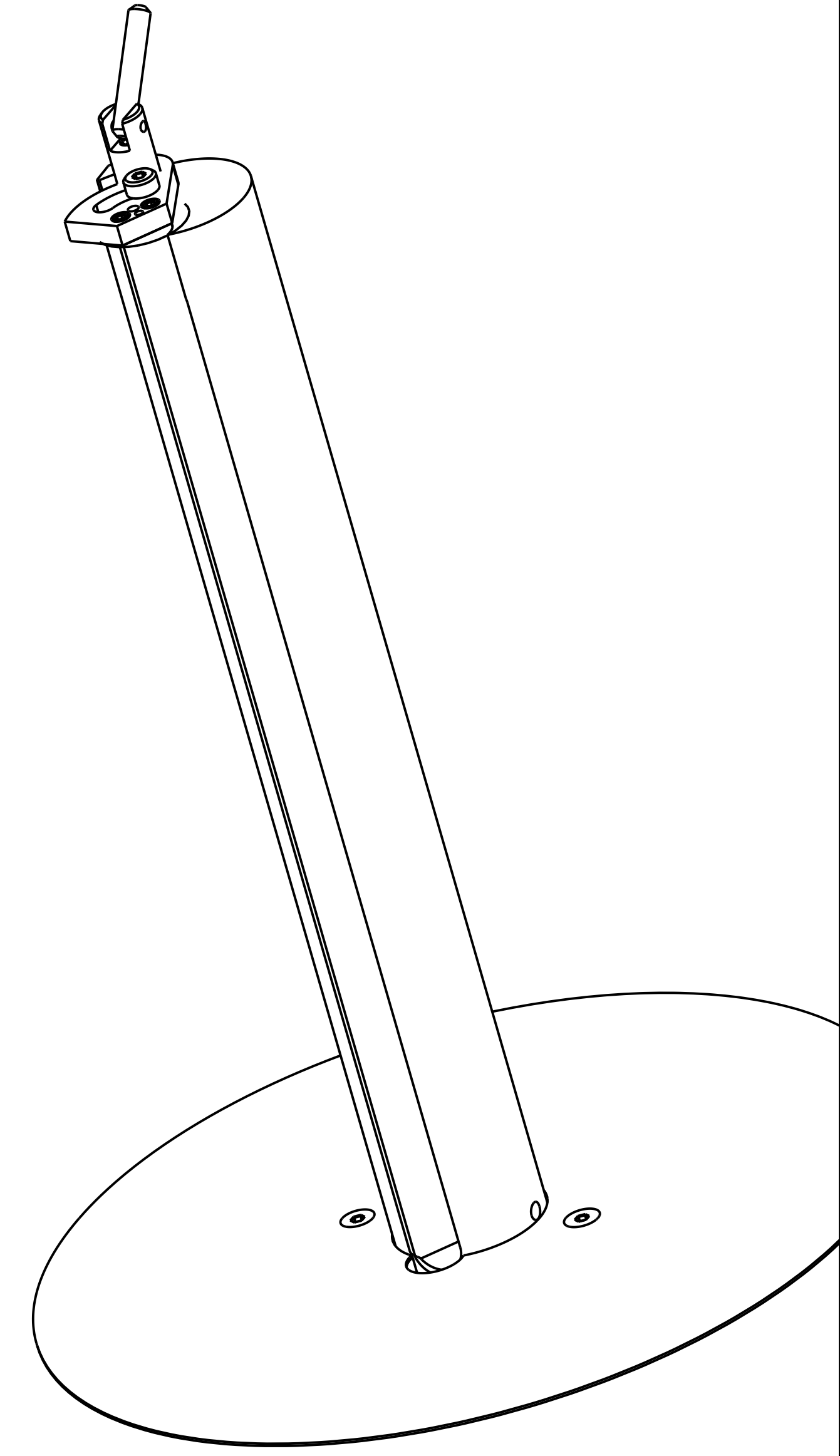
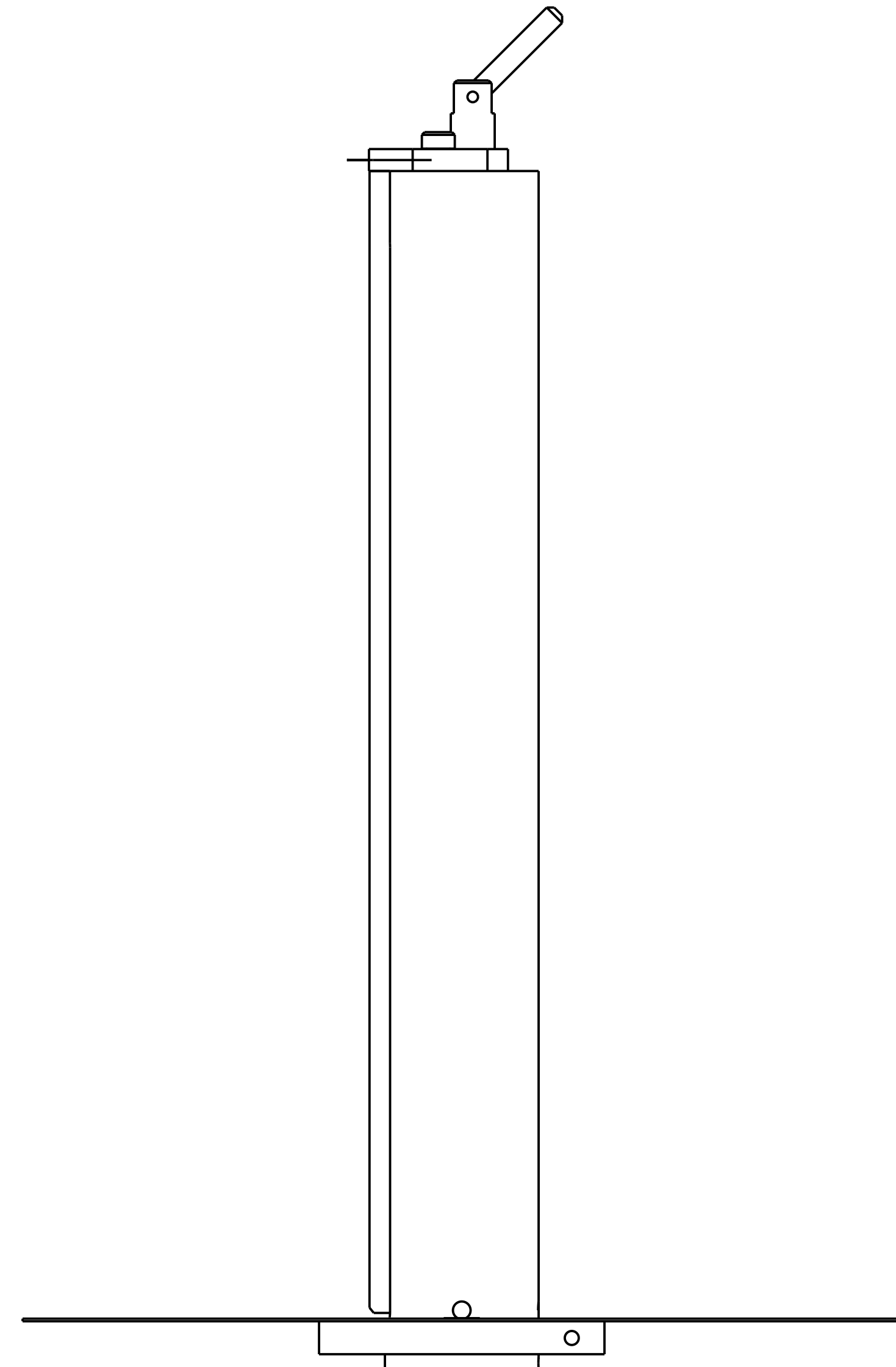

THIS IS A PRO-ENGINEER DOCUMENT AND MAY NOT BE MODIFIED MANUALLY

REV	DATE	DESCRIPTION	BY
A	Jun-06-17	NEW DRAWING	CRT

UNLESS OTHERWISE SPECIFIED DIMENSIONAL TOLERANCE	X± .1 XX± .01 XXX± .005 ANGLES ± .30°	QUADREL LABELING SYSTEMS 7670 JENTHER DRIVE MENTOR, OHIO 44060 (440) 602-4700	SCALE 3/4 DATE Jun-06-17 DRAWN BY CRT
SURFACE FINISH 125 BREAK ALL EDGES .005/015 CORNER RADIUS .010/030		MAT'L	COLLAPSIBLE REWIND 22189-113

ITEM	QTY	PART NO.	DESCRIPTION
1	1	871352-000	DOWELL,PIN 1/8" x 1/2" SS.
2	1	A26128-000	CLEVIS
3	1	A26129-000	HANDLE
4	1	SYE601	1/4-20 X 1-1/4 LG. SET SCREW

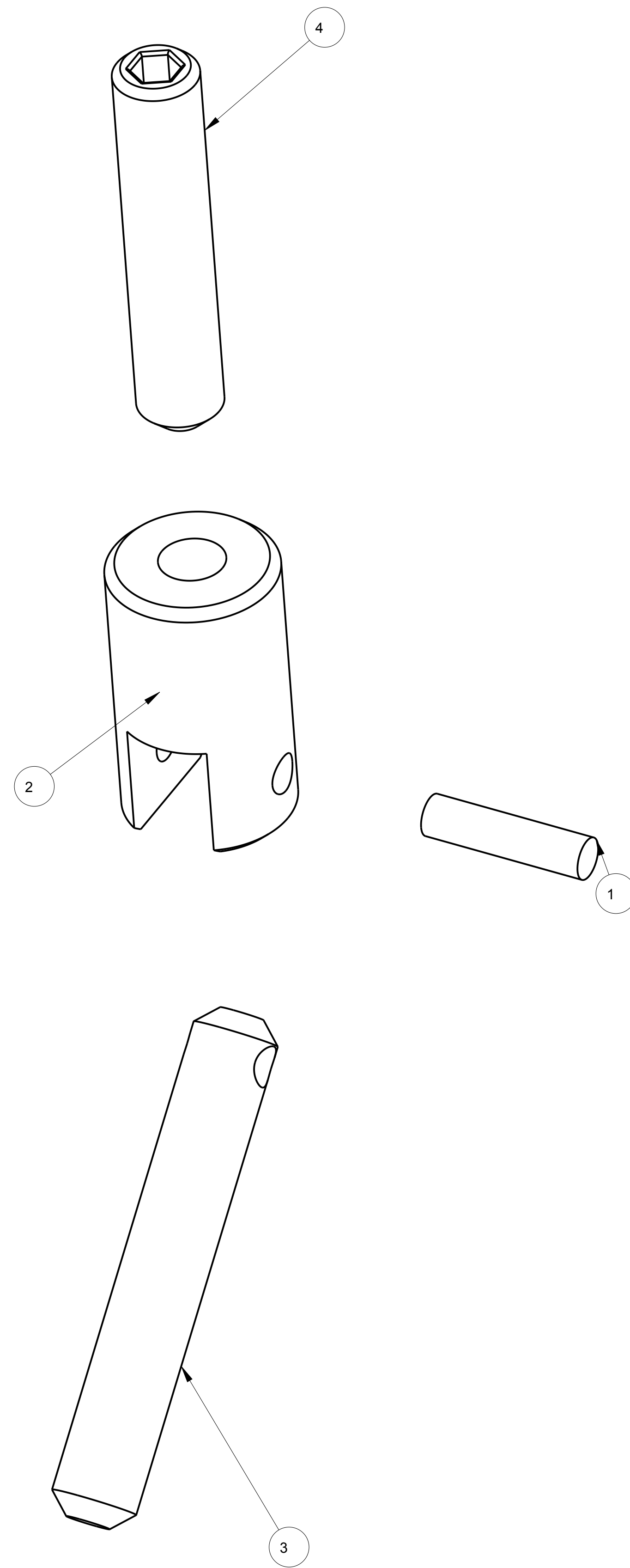

REV	DATE	DESCRIPTION	BY
A	12-11-14	NEW DRAWING	

THIS IS A PRO-ENGINEER DOCUMENT AND MAY NOT BE MODIFIED MANUALLY

UNLESS OTHERWISE SPECIFIED DIMENSIONAL TOLERANCE .X± .1 .XX± .01 .XXX± .005 ANGLES ± 30°	QUADREL LABELING SYSTEMS 7670 JENTHER DRIVE MENTOR, OHIO 44060 (440) 602-4700		SCALE 4/1 DATE 12-11-14 DRAWN BY ATT
	COLLAPSIBLE REWIND LOCKING HANDLE		
	SURFACE FINISH 125 BREAK ALL EDGES .005/.015 CORNER RADIUS .010/.030	MAT'L 22597-000	22597-000

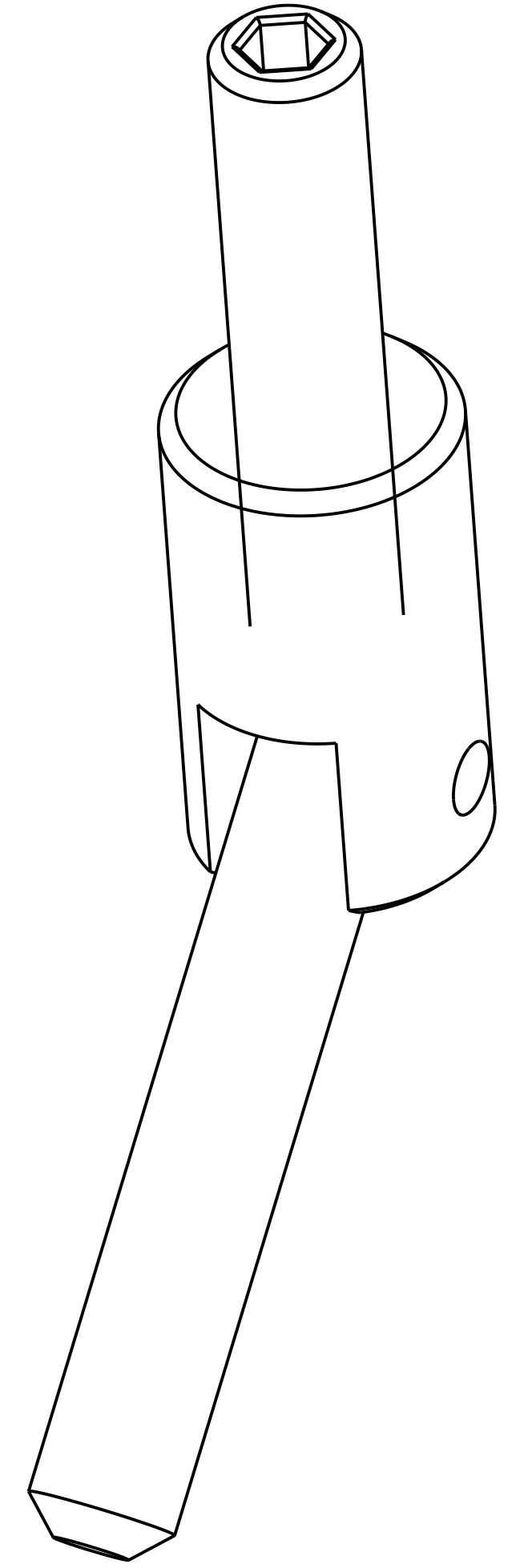
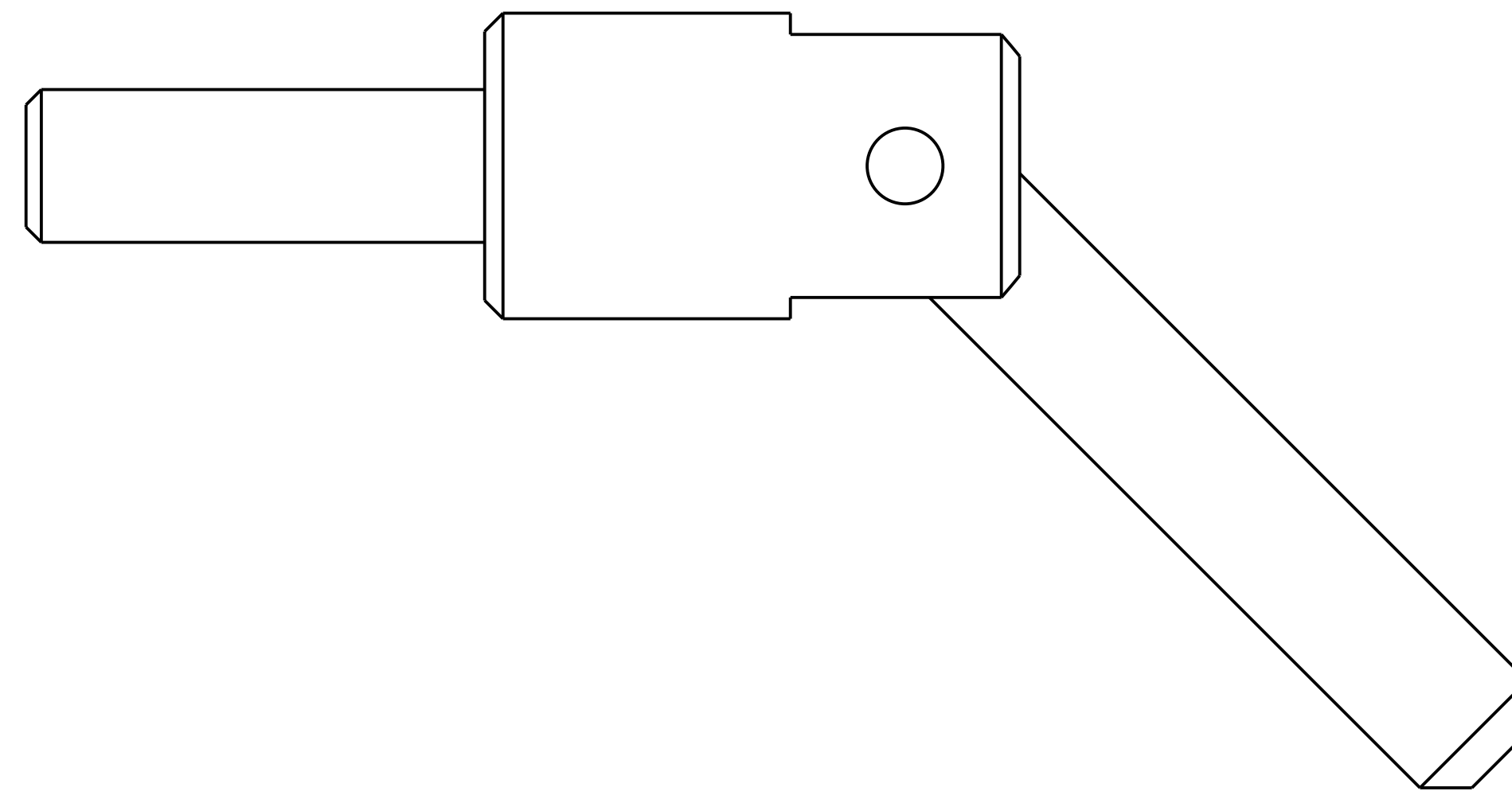
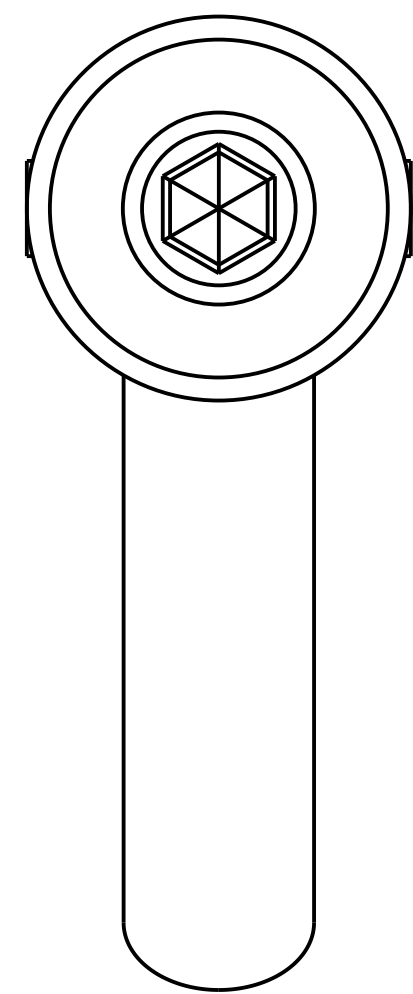
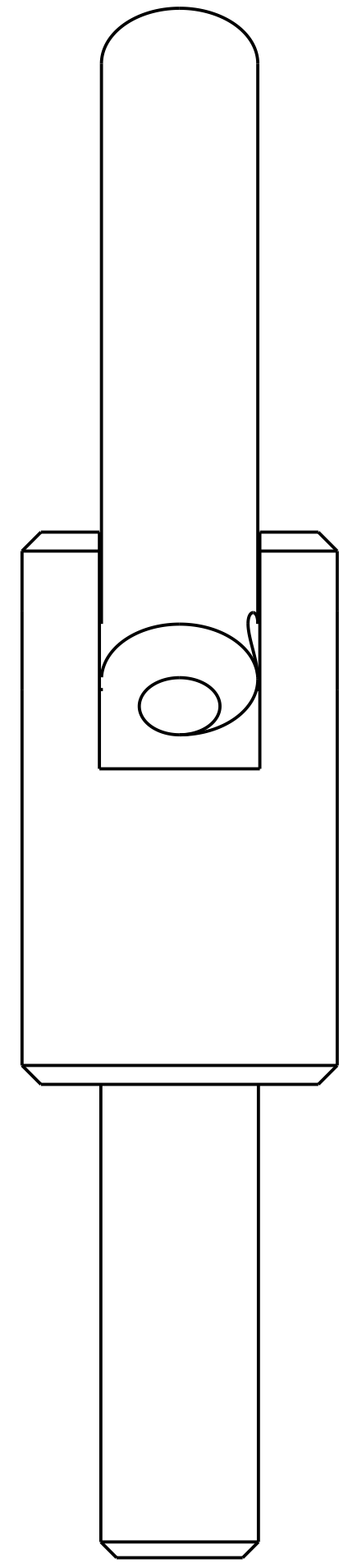

UNLESS OTHERWISE SPECIFIED DIMENSIONAL TOLERANCE		X± .1 XX± .01 XXX± .005 ANGLES ± .30°	
SURFACE FINISH 125 BREAK ALL EDGES .005/015 CORNER RADIUS .010/030		MAT'L 22597-000	

THIS IS A PRO-ENGINEER DOCUMENT AND MAY NOT BE MODIFIED MANUALLY			
REV	DATE	DESCRIPTION	BY
A	12-11-14	NEW DRAWING	
QUADREL LABELING SYSTEMS 7670 JENTHER DRIVE MENTOR, OHIO 44060 (440) 602-4700		SCALE	4/1
		DATE	12-11-14
		DRAWN BY	ATT
COLLAPSIBLE REWIND LOCKING HANDLE			
			22597-000

ASSEMBLY TITLE: SLOT SENSOR ASSEMBLY

GENERAL FUNCTION:

- The slot sensor detects the separation between labels. This signals the electronics to stop the drive motor.
- The two (2) liner support rods prevent the liner from wearing out the slot sensor.
- The knob and thumbscrew lock the sensor firmly on the mounting rods.
- The male connector provides quick connection to the labeling head.

SET UP AND ADJUSTMENTS:

- With the labeling head threaded and the proper label flag at the peel plate, slide the slot sensor along the guide rods and tighten it just past a label division (away from the peel plate)
- Apply main power and remove label material from sensor forks
- Turn sensitivity screw on slot sensor 15 turns CCW. The indicator light will be off.
- Remove a label from the label liner and place the liner only portion between the sensor forks.
- Turn the sensitivity screw CW until the indicator light turns ON.
- Then turn the sensitivity screw CW 2 more full turns.
- Correct set up is achieved when the indicator lamp is OFF through the entire label surface and ON when the division between labels passes between the sensor forks.

MAINTENANCE:

- Keep the sensor optical area clean from label and glue residue

TROUBLESHOOTING:

<u>PROBLEM</u>	<u>WHAT TO DO</u>
- No power to the sensor	- Check male connector and tightly secure connection to the head.
- Liner dragging over the slot	- Loosen knob and rotate slot sensor slot sensor surface liner rests on both support rods
- Too much slack through slot sensor	- Adjust brake brush tension
- Slot sensor moving with web	- Tighten all three (3) adjusting knobs

ITEM	QTY	PART NO.	DESCRIPTION	PARENT ITEM
1	1	201444-301	SENSOR	20033-343
2	2	801297-000	THUMB SCREW PLSTC HEAD 8-32x1	20033-343
3	2	801299-000	KNOB W/STUD, 1/4-20 UNC X 1/2" LG	20033-343
4	1	A21391-300	SLOT SENSOR ADAPTER	20033-343
5	4	A21749-300	SLOT SENSOR SUPPORT ROD MTG BLOCK	20033-343
6	2	A21770-343	14.7" SUPPORT ROD WITH FLAT	20033-343
7	1	B20852-343	12 IN. WEB SLOT SENSOR MTG. BAR	20033-343

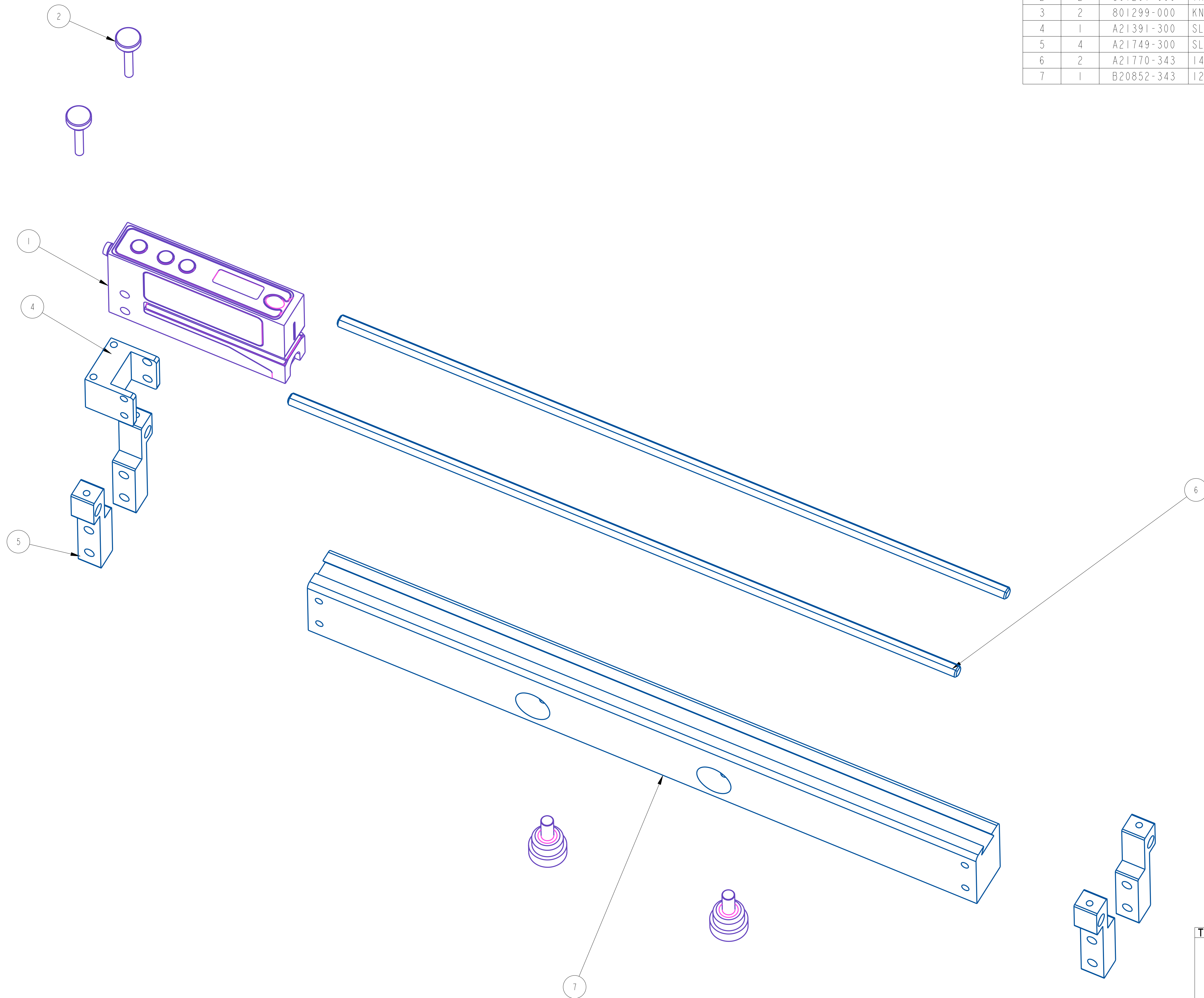

SHEET 1 OF 2

REV	DATE	DESCRIPTION	BY
A	Mar-11-25	NEW DRAWING	TAZ

THIS IS A PRO-ENGINEER DOCUMENT AND MAY NOT BE MODIFIED MANUALLY

UNLESS OTHERWISE SPECIFIED DIMENSIONAL TOLERANCE	SCALE: 1/1
.X ± .1	DATE: Mar-11-25
.XX ± .01	DRW BY: TAZ
.XXX ± .005	CHK BY: 03/15/2025-SEM
ANGLES ± 30°	APPR BY:

QUADREL LABELING SYSTEMS
7670 JENTHER DRIVE
MENTOR, OHIO 44060
(440) 602-4700

12" CLEAR LABEL DETECT ASSEMBLY

MAT'L	20033-343	20033-343
-------	-----------	-----------

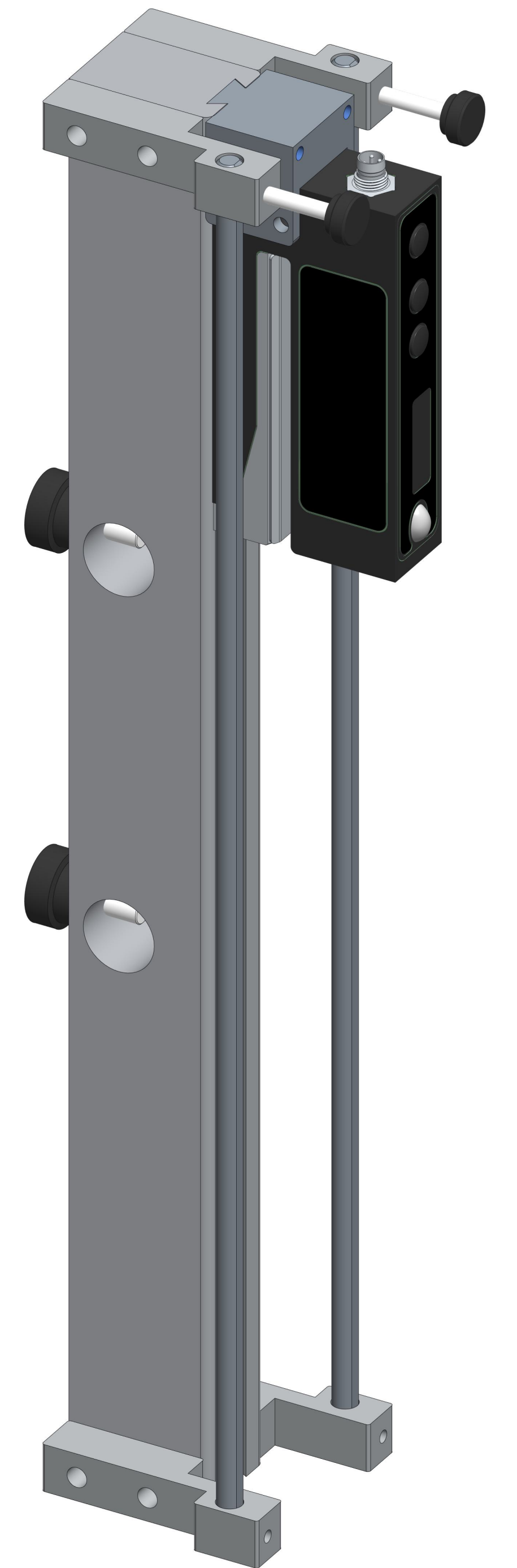
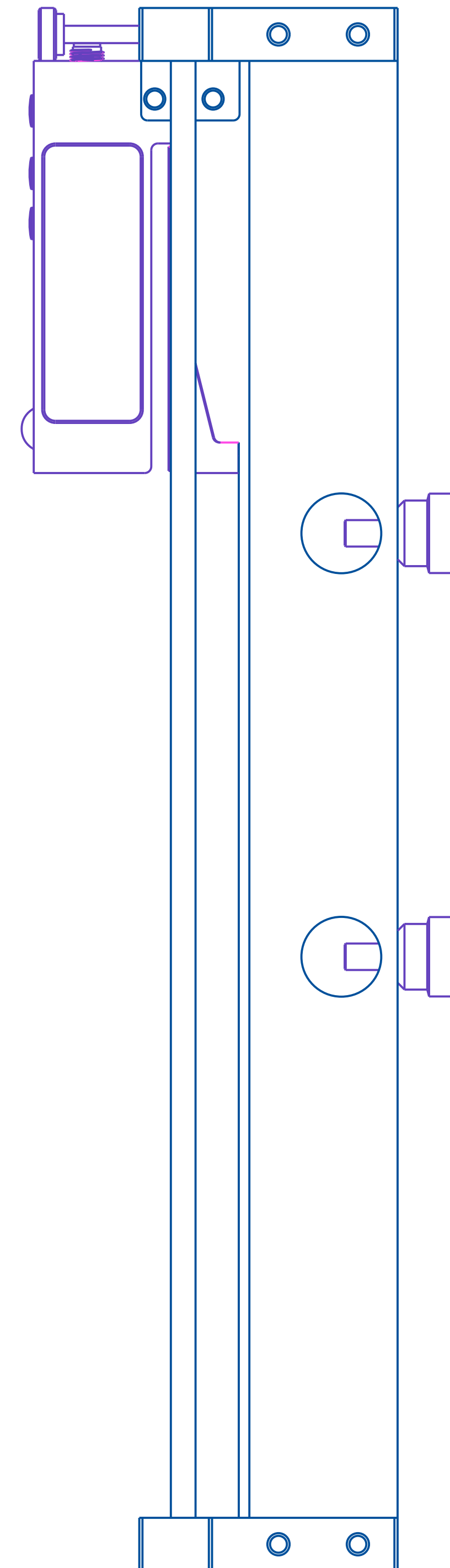
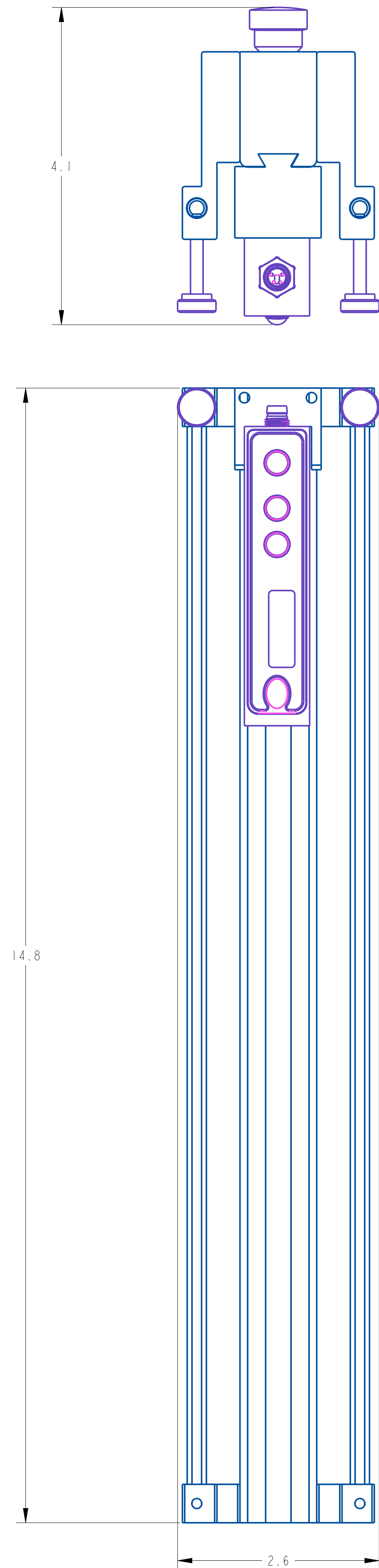

SHEET 2 OF 2

THIS IS A PRO-ENGINEER DOCUMENT AND MAY NOT BE MODIFIED MANUALLY			
A	Mar-11-25	NEW DRAWING	TAZ
REV	DATE	DESCRIPTION	BY
QUADREL LABELING SYSTEMS 7670 JENTHER DRIVE MENTOR, OHIO 44060 (440) 602-4700			SCALE: 1/1 DATE: Mar-11-25 DRW BY: TAZ CHK BY: 03/15/2025-SEM APPR BY:
12" CLEAR LABEL DETECT ASSEMBLY		MAT'L	
20033-343		20033-343	

Installation Manual

CLSC-1M8LEX185



1. Position Label

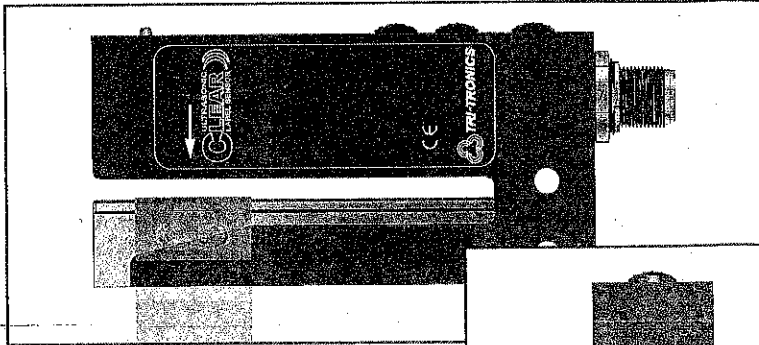

Align Label to Arrow (above)
Place the label web so that it is centered on the arrow. The arrow is where the transducers are aligned.

Align Gap to Line (right top)
Place label gap in center of the sensor using the alignment line as shown on right. When viewing from the top of the sensor, use the output LED to center label gap.

Gentle Tension (right bottom)
Place label webbing so that it slides along the bottom of the sensor gap plate. This will ensure a more consistent setup and performance.

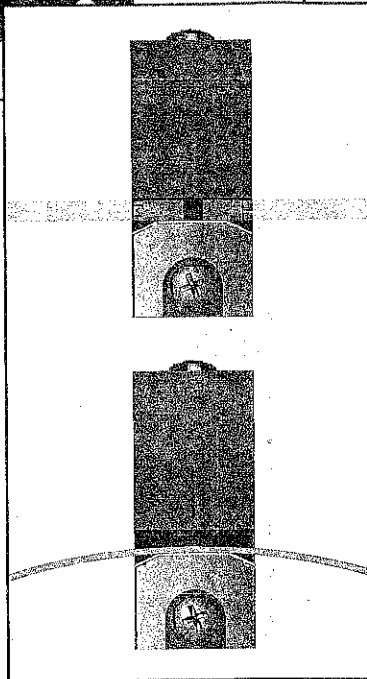

2. Setup Instructions

Once the Gap is in view, press and hold the AUTOSET/GAP button for two seconds. This will result in a stable setup most every time. If you have any false triggers, put the Label in view, push and hold the AUTOSET/LABEL button for two seconds. This two-point setup will create a new threshold setting resulting in a more consistent signal span between web and label.

Note: Manual adjust by tapping arrows.

MULTI-FUNCTION OUTPUT INDICATOR

1. Illuminates when outputs are ON.
Note: Flashes when short circuit is detected.
2. Rapid flash indicates AUTOSET start (wait two seconds to complete).
3. Single flash during manual adjust.

AUTOSET/GAP Δ BUTTON

1. Push and Hold with gap in view for two seconds for AUTOSET.
2. Tap for UP to lower threshold.

AUTOSET/LABEL ∇ BUTTON

1. Push and Hold with label in view after GAP AUTOSET on rare occasions when labels have multiple layers.
2. Tap DOWN to increase threshold.

LT/DK Toggle
Light / Dark output toggle (inverts output).

Specifications



SUPPLY VOLTAGE

- 12 to 30 VDC
- Polarity Protected
- Note: For use in Class 2 Circuits*

CURRENT REQUIREMENTS

- 95mA @ 12 VDC, 45mA @ 30 VDC

DIGITAL OUTPUTS

- (1) NPN and (1) PNP open collector output 150mA Max; <2V Residual Voltage
- All outputs are continuously short circuit protected

DIAGNOSTIC INDICATOR

- Illuminates when when outputs are ON.
- Note: Flashes when short circuit is detected.*
- Rapid flash indicates AUTOSET start (wait two seconds to complete).
- Single flash during manual adjust.

PUSHBUTTON CONTROL

- Three (3) push button controls
- Gap (for Gap AUTOSET)
- Label (for multi-layered labels)
- LT/DK= Light / Dark toggle

HYSTERESIS

- Dynamic – adjusted by AUTOSET

RESPONSE TIME

- 200µs

REPEATABILITY

- 125µs

AMBIENT TEMPERATURE

- 4°C to 50°C (39°F to 122°F)

RUGGED CONSTRUCTION

- Chemical resistant, high impact Aluminum housing
- Waterproof ratings: IP65
- Conforms to heavy industry grade CE requirements

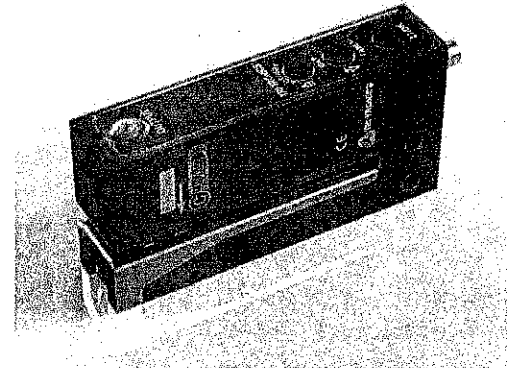

THRESHOLD SET

- 1-Point, 2-Point.

THRESHOLD ADJUST

- Manual Adjust

CONNECTOR

- M8 4-Pin

RoHS Compliant
Product subject to change without notice

Connections and Dimensions

Ultrasonic Clear Label Sensor X185

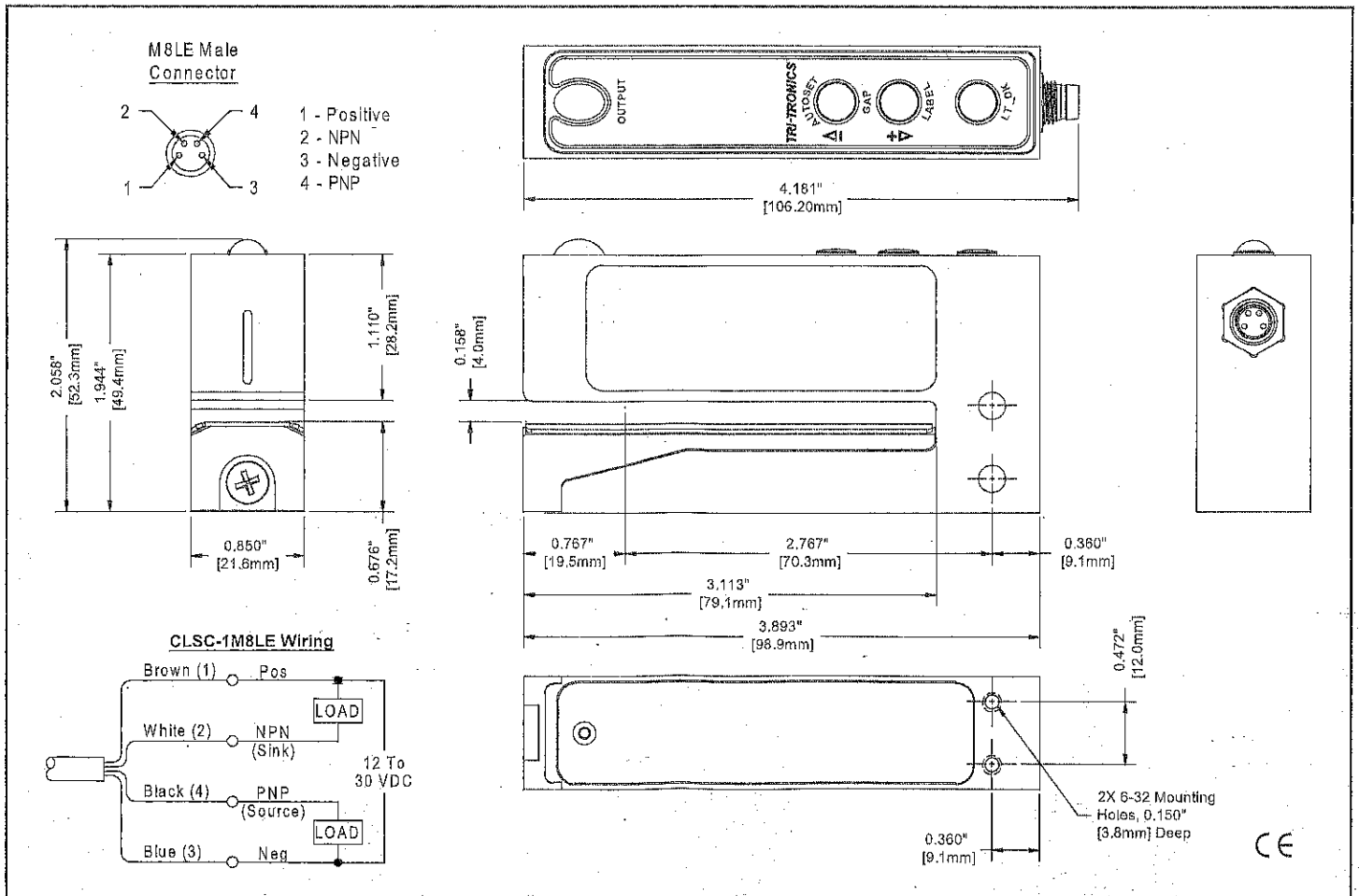

ASSEMBLY TITLE: LOW LABEL FAULT ASSEMBLY

DRAWING NO.:

GENERAL FUNCTION:

- The low label supply fault indicates a depleting supply of labels. It consists of a fiber optic sensor that is set at the desired position on the roll of labels.
- When the label supply passes below the sensor range, a signal is generated this will light the yellow stack lamp and enunciate a low label condition on the operator's touch screen display.
- The male connector provides quick connection to the labeling head.

SET UP AND ADJUSTMENTS:

- Set the sensor eye just before the cardboard inner core, approximately ¼" below the supply reel flange and lined up with the sensing hole in the flange.

MAINTENANCE:

- Keep the sensor optical area clean from label and glue residue

TROUBLESHOOTING:

<u>PROBLEM</u>	<u>WHAT TO DO</u>
- No power to the sensor	- Check male connector and tightly secure connection to the head.

NOTE: The labeler will continue to operate until the operator pauses the labeler or the label supply completely depletes past the broken web sensor.

To reset the fault condition, replenish the label supply and press the labeler run button from run to pause and back to run.

ITEM	QTY	PART NO.	DESCRIPTION	PARENT ITEM
1	1	202201-000	DUAL DIGITAL FIBER AMPLIFIER	20776-006
2	1	202201-001	DUAL DIGITAL FIBER AMPLIFIER	20776-006
3	1	203170-000	CABLE, FIBER , REFLECTIVE, KEYENCE #FU-67V	20776-006
4	1	A23727-000	LOW LEVEL BRACKET	20776-006
5	1	A23728-000	LOW LEVEL SENSOR TUBE	20776-006

*NOT SHOWN
252019-000 CONNECTOR

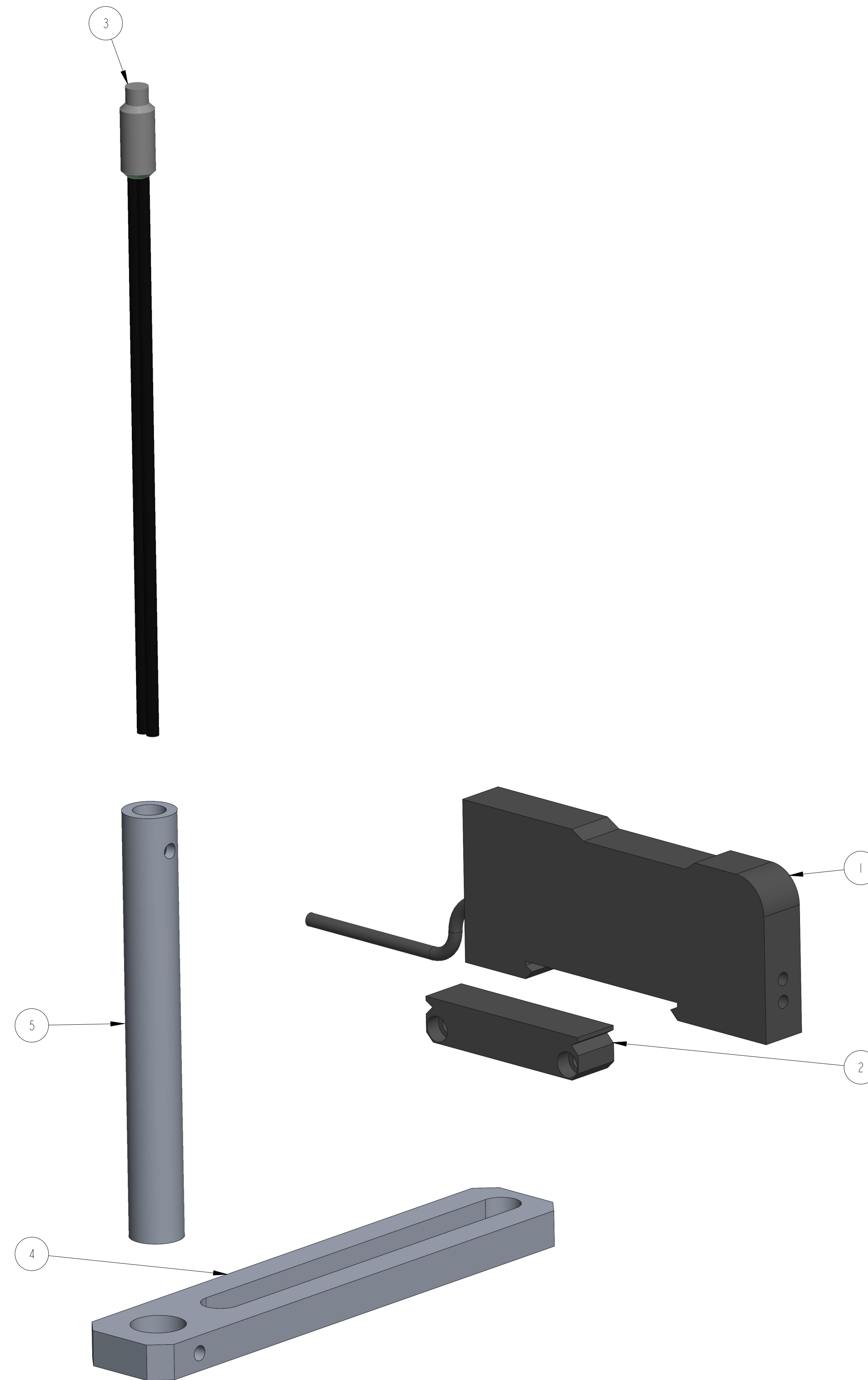

REV	DATE	DESCRIPTION	BY
A	Apr-07-21	NEW DRAWING	TJS

THIS IS A PRO-ENGINEER DOCUMENT AND MAY NOT BE MODIFIED MANUALLY

QUADREL LABELING SYSTEMS
7670 JENTHER DRIVE
MENTOR, OHIO 44060
(440) 602-4700

SCALE: 2/1
DATE: Apr-07-21
DRAWN BY: TJS

MAT'L: 20776-006 & 20776-006P
20776-006

LOW LABEL

UNLESS OTHERWISE SPECIFIED
DIMENSIONAL TOLERANCE
XX ± .01
XXX ± .005
ANGLES ± 30°
SURFACE FINISH: 125
BREAK ALL EDGES .005/.015
CORNER RADIUS .010/.030

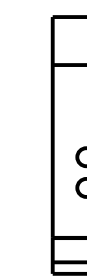
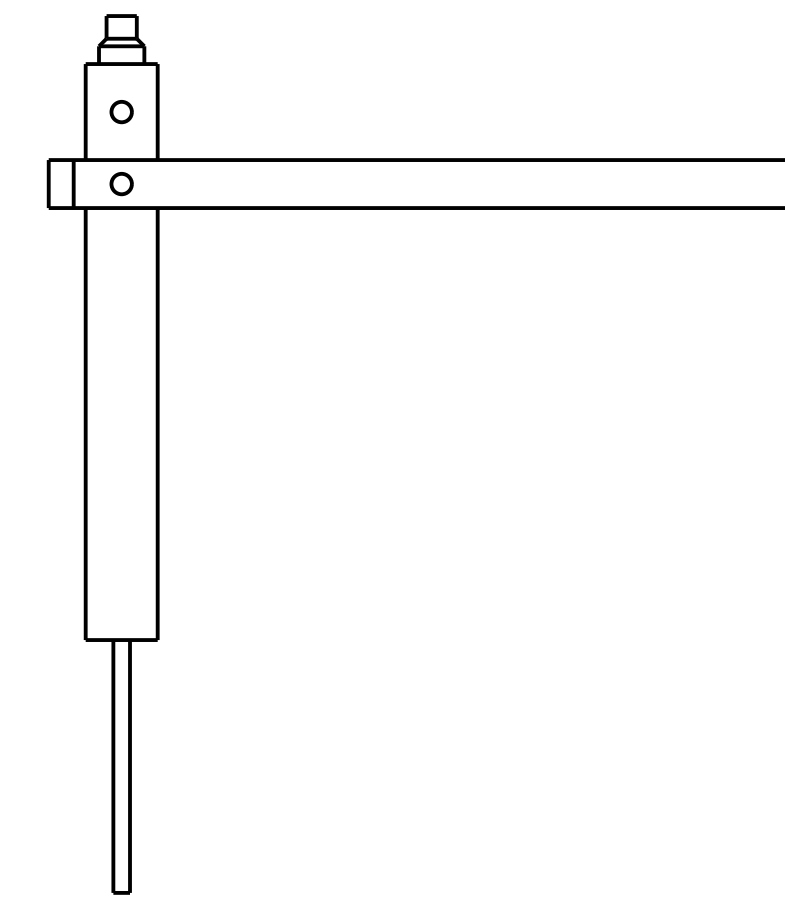
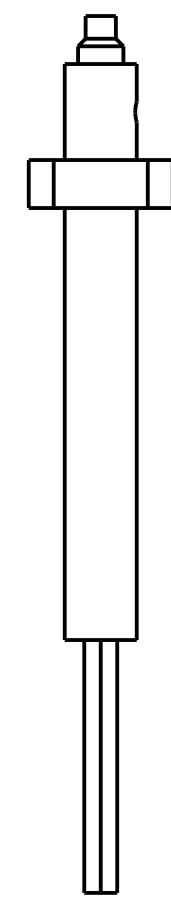
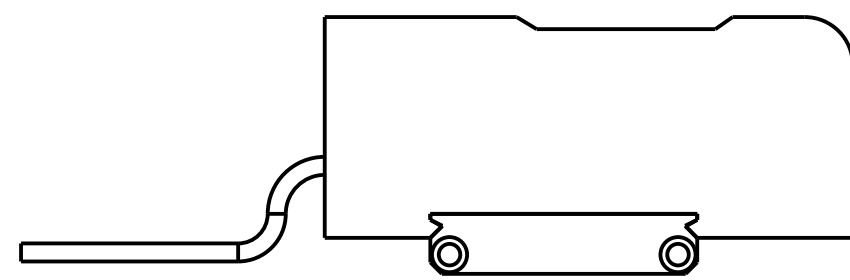
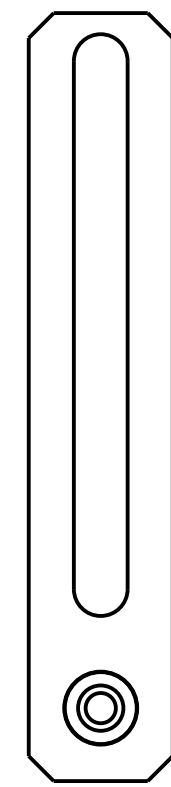
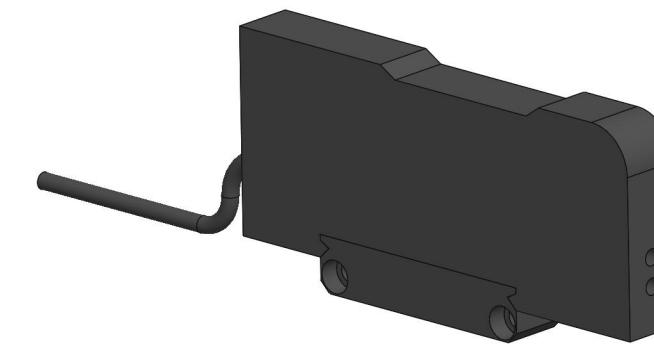

UNLESS OTHERWISE SPECIFIED		NEW DRAWING		TJS
DIMENSIONAL TOLERANCE		DATE	DESCRIPTION	BY
x ± .1		Apr-07-21		
xx ± .01				
xxx ± .005				
ANGLES ± 30°				
SURFACE FINISH 125		SCALE 1/1		
BREAK ALL EDGES .005/015		DATE Apr-07-21		
CORNER RADIUS .010/030		DRAWN BY TJS		
		LOW LABEL		
MAT'L		20776-006 & 20776-006P		20776-006

THIS IS A PRO-ENGINEER DOCUMENT AND MAY NOT BE MODIFIED MANUALLY

QUADREL LABELING SYSTEMS
7670 JENTHER DRIVE
MENTOR, OHIO 44060
(440) 602-4700



Digital Fiberoptic Sensor FS-N40 Series Instruction Manual

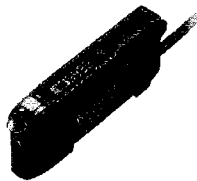

Read this manual before using the product in order to achieve maximum performance. Keep this manual in a safe place after reading it so that it can be used at any time.

For detailed FS-N40 Series setting methods and for details on the functions of the FS-N40 Series, see the "FS-N40 Series User's Manual".

■ Symbols

The following symbols are used in this instruction manual to enable the recognition of important information at a glance. Be sure to read these messages carefully.

	It indicates a hazardous situation which, if not avoided, will result in death or serious injury.
	It indicates a hazardous situation which, if not avoided, could result in death or serious injury.
	It indicates a hazardous situation which, if not avoided, could result in minor or moderate injury.
	It indicates a situation which, if not avoided, could result in product damage as well as property damage.

1 Before Operation

Safety Precautions

	<ul style="list-style-type: none"> This product is only intended to detect objects. Do not use this product for the purpose of protecting a human body or a part of a human body. This product is not intended for use as an explosion-proof product. Do not use this product in a hazardous location and/or potentially explosive atmosphere.
	<ul style="list-style-type: none"> This is a direct current (DC) power supply type sensor. Application of an alternating current may result in explosion or fire.
	<ul style="list-style-type: none"> Use separate conduits for power lines and high-voltage lines. Use of a common conduit may result in device malfunction due to noise or damage to the sensor. Always ground the frame ground terminal when using an off-the-shelf switching regulator. Do not use this product outdoors.

Precautions on Regulations and Standards

■ CE Marking

KEYENCE Corporation has confirmed, on the basis of the following specifications, that this product complies with the essential requirements of the applicable EU Directive(s). Be sure to consider the following specifications when using this product in the member states of the European Union.

● EMC Directive, applicable standard: EN60947-5-2, Class A

Ensure that the cable length is 30 meters or less. These specifications do not give any guarantee that the end-product with this product incorporated complies with the essential requirements of the EMC Directive. The manufacturer of the end-product is solely responsible for confirming the compliance of the end-product itself according to the EMC Directive.

■ UL Certificate

This product is a UL/c-UL certified product.

- UL File No.: E301717
- Category: NRKH/NRKH7(NRKH2/NRKH8: FS-N42N(P))
- Enclosure Type 1 (based on UL50)

Be sure to consider the following specifications when using this product as a UL/c-UL certified product.

- Use a power supply with Class 2 output defined in NFPA70 (NEC: National Electrical Code).
- Connect the power supply, external input, and control output to a single power supply with Class 2 output.
- Use OP-73864, OP-73865 or OP-85498 cable with FS-N41C when the field wiring is required.

■ FCC Regulations

This product complies with the following regulations specified by the FCC.

- Applicable regulation FCC Part 15 Subpart B Class A
- This device complies with part 15 of the FCC Rules. Operation is subject to the following two conditions: (1) This device may not cause harmful interference, and (2) this device must accept any interference received, including interference that may cause undesired operation.

• FCC Caution

Changes or modifications not expressly approved by the party responsible for compliance could void the user's authority to operate the equipment.

Package Contents

- Main unit
- Instruction manual

2 Installation and Wiring

Mounting the Main Unit

■ Mounting the Main Unit on a DIN rail

- 1 Align the claw at the bottom of the main unit with the DIN rail, as shown in the figure. While pushing the main body in the direction of arrow 1, push down in the direction of arrow 2.
- 2 To remove the sensor, raise the main body in the direction of arrow 3 while pushing the main body in the direction of arrow 1.

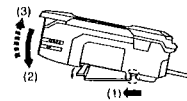

■ Installation on a wall (main unit only)

- 1 Attach the main unit to the optional mounting adapter (OP-88245), and then insert M3 screws into the two locations shown in the figure to secure the main unit in place.

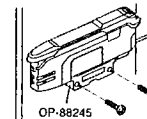

Connecting Multiple Amplifiers

Up to 16 expansion units can be connected to 1 main unit. However, each dual output type will be treated as 2 expansion units.

	When connecting to multiple amplifiers or when mounting main units together, mount the units on a DIN rail installed on a metal surface.
	<ul style="list-style-type: none"> • Be sure to turn the power off before connecting multiple expansion units. • Do not touch the expansion connector.

- 1 Remove the protection covers from the main unit and expansion unit(s).

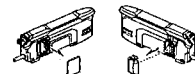

- 2 Install the amplifiers on the DIN rail one at a time.

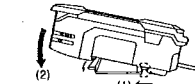

- 3 Slide the main unit and expansion unit(s) together. Mate the two claws of the expansion unit with the recesses on the main unit side until a click is heard/felt.

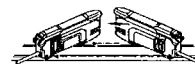

- 4 Attach the end units (optional, sold separately: OP-26751) to the DIN rail on both sides of the amplifiers in the same way as step (2).

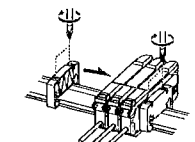

- 5 Secure the amplifiers between the end units. Tighten the screws from the top (two screws x two units) with a Phillips screwdriver to fix the end units in place.

OP-26751 (a set of two)

Fiber Unit Installation

■ Using a fiber cutter

- 1 Insert the fiber into the cutter hole.
- 2 Bring down the blade in a single, swift motion to cut the fiber. (Do not use a hole that has already been used.)

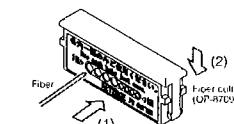

Always insert fiber from the side with writing

■ Connecting to the amplifier unit

- 1 Open the cover (1), and then lower the lever in the direction indicated by (2).
- 2 Insert the fiber unit into the installation holes (approximately 14 mm). (3)
- 3 Move the lever back in the direction indicated by (4).

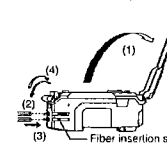

	When installing a coaxial reflective fiber in the main unit, install the single-core fiber in the transmission installation hole and the multi-core fiber in the reception installation hole.
--	---

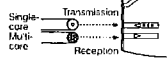

Wiring (Cable Type)

● FS-N41N/N42N/N43N/N44N

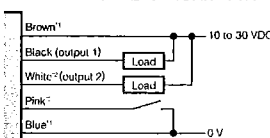

- *1 FS-N41N/N43N only
- *2 FS-N43N/N44N only

● FS-N41P/N42P/N43P/N44P

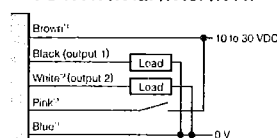

- *1 FS-N41P/N43P only
- *2 FS-N43P/N44P only

Wiring (M8 Connector Type: FS-N41C)

Select NPN or PNP and the function of I/O pin (2) during the initial settings.

Sensor pin layout



FS-N41C supports "IO-Link: Specification V.1.1/COM2 (38.4 kbps)". The setting file (IODD) can be downloaded from Keyence's web site (<http://www.keyence.com>).

● When using the sensor in PNP mode

OUT1 + OUT2

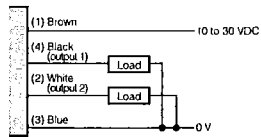

OUT1 + INPUT

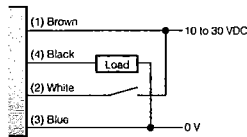

● When using the sensor in NPN mode

OUT1 + OUT2

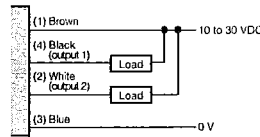

OUT1 + INPUT

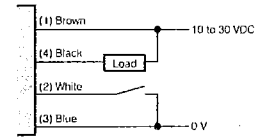

The wire colors indicate the colors when using an OP-73864/73865 M8 connector cable (sold separately).

3 Basic Settings

■ Names and functions

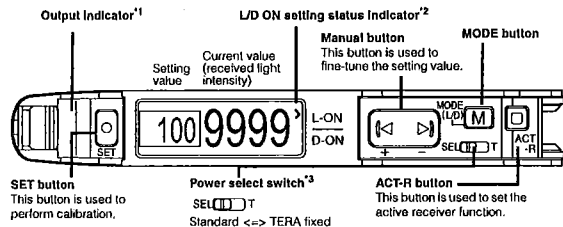

- *1 On dual output types (including the FS-N41C), the indicator operates according to the output channel selected with the output channel selection switch.
- *2 On dual output types (including the FS-N41C), this becomes the output indicator. It displays the current output status of channels 1 and 2.
- *3 On dual output types (including the FS-N41C), this becomes the output channel selection switch. It is not present on zero line types (FS-N40).

■ Initial settings (FS-N41C only)

When turning on the sensor for the first time, or when the sensor has been initialized, select the initial settings shown below.

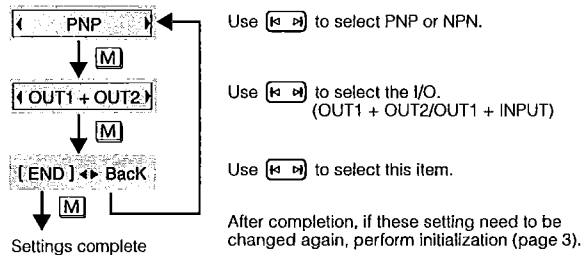

■ Basic settings

● Switching the output style (Light ON/Dark ON)

- 1 Press **[M]** once. Switch L-On/D-On
- 2 Use **[< >]** to switch the output style.
- 3 Press **[M]** three times.

● Switching the display language

- 1 Press **[M]** twice. Language / 语言
- 2 Use **[< >]** to select the language.
- 3 Press **[M]** twice.

● Fine-tuning the setting value (threshold)

Use **[< >]** to adjust the value. Hold down the button to make adjustments more quickly.

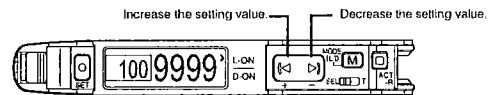

■ Basic calibration methods

● 2-point calibration (the most basic setting method)

1 Press **[SET]** with no object to detect present.

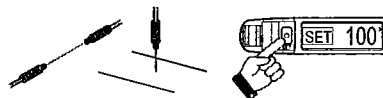

2 Press **[SET]** with an object to detect present.

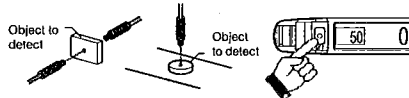

This sets the setting value to the midpoint between the received light intensities of points 1 and 2. If "..." blinks for 2 seconds on the display, the difference between the received light intensities is small, and detection may be unstable.

● Maximum sensitivity calibration

Through-beam model: With an object to detect present

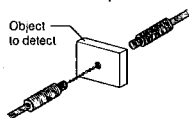

Reflective model: With no object to detect present



1 With the items arranged as shown in the figures on the left, hold down **[SET]** for 3 seconds or more. When **[SET]** blinks, release this button.

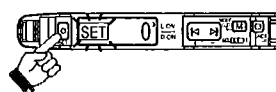

The setting value is set slightly higher than the received light intensity when the setting was configured.

4 Useful Functions

● Initialization

Initialize all the settings and return the sensor to its factory default state.

- 1 Hold down and for 3 seconds or more.
- 2 Press once.
- 3 Press once.
- 4 Press once.

● Key lock

Disable button operations.

- 1 Hold down and for 3 seconds or more.

Cancel: Use the same procedure.

● Active receiver (ACT-R)

This function makes the fiber unit's receiver blink in green.

Operation when the sensor is shipped from the factory

When the sensor output is ON, the fiber unit's receiver lights in green. (This is linked to the output.)

To change the normal lighting status of the receiver (change the settings)

- 1 Press three times.
- 2 Use to select the status from those shown below.

Output Link: The receiver will light when the output is ON.
Reversed Op: The receiver will light when the output is OFF.
Always On: The receiver will be lit always.
Disable: The receiver will be off always.

- 3 Press twice to return to the normal status.

To force the receiver to blink in green (pairing mode)

- 1 Press once.
- 2 Press .
- 3 The light-receiving side blinks in green.
- 4 Press four times to return to the normal status.

● Saturation avoidance function

Use this function when the received light intensity does not change from the maximum displayed value.

- 1 Press and simultaneously.

Cancel: Use the same procedure.



● Zero shift function

Use this function to change the received light intensity display to zero.

- 1 Press and simultaneously.

Cancel: Hold down and for 3 seconds or more.

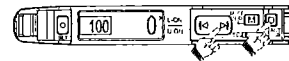

To make it easy to perform optical-axis alignment (optical-axis alignment assist mode)

- 1 Press twice.
- 2 Press to make the light-receiving side blink in green.
- 3 Move the tip of the fiber unit within the movable range.

The light-receiving side lights in green near the peak light intensity within the range in which the tip moved.

Align the optical axis within the middle of the range in which the light-receiving side lights.

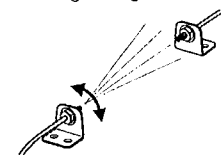

- 4 When you finish the alignment, press three times.

The sensor returns to the normal status.

5 Specifications

The response times are listed on the following page.

Model	NPN output		FS-N41N	FS-N42N	FS-N43N	FS-N44N	FS-N41C ¹		FS-N40
	PNP output		FS-N41P	FS-N42P	FS-N43P	FS-N44P	(selectable output)		
Cable/conductor	Cable						MS connector ²		-
Main unit/expansion unit	Main unit		Expansion unit		Main unit		Expansion unit		Expansion unit
Number of control outputs	1		1		2		2 ³		None ⁴
Number of external inputs	-		-		1		1		1 ³
Light source LED	Transmitter side: Red, four-element LED (wavelength: 660 nm)								
Control output	Open-collector, 30 V or less 100 mA or less per output, 100 mA or less total for 2 outputs (when used as a solitary unit) 20 mA (when used as an expansion unit)								
	Residual voltage	NPN 1.4 V or less (output current: 10 mA or less) 2 V or less (output current: 10 to 100 mA) PNP 1.6 V or less (output current: 10 mA or less) 2.2 V or less (output current: 10 to 100 mA)							
External input	Input time: 2 ms (ON)/20 ms (OFF) or longer ⁵								
Unit expansion (excluding the FS-N41C)	Up to 16 units (17 units connected in total including the main unit). However, each two output type will be treated as two expansion units.								
Protection circuit	Protection against reverse power connection, output overcurrent, output surge, and reverse output connection								
Mutual interference prevention	S-HSPD/HSPD: 0 units, FINE: 4 units, TURBO/SUPER/ULTRA/MEGA/TERA: 8 units (The mutual interference prevention values are twice those shown here when Double Is set.)								
Power supply	Power supply voltage								
	10 to 30 VDC (including 10% ripple (P-P) or less), class 2 or LPS ⁶								
Power consumption ⁷	NPN FS-N40								
	During normal operation: 870 mW or less (34 mA or less at 24 V/62 mA or less at 12 V) ECO ON: 800 mW or less (31 mA or less at 24 V/56 mA or less at 12 V) ECO FULL: 710 mW or less (28 mA or less at 24 V/49 mA or less at 12 V)								
Power supply	PNP FS-N41C								
	One output type (FS-N41P/N42P) and FS-N41C During normal operation: 910 mW or less (36 mA or less at 24 V/65 mA or less at 12 V) ECO ON: 840 mW or less (33 mA or less at 24 V/60 mA or less at 12 V) ECO FULL: 750 mW or less (30 mA or less at 24 V/52 mA or less at 12 V)								
Power supply	Two output type (FS-N43P/N44P)								
	During normal operation: 990 mW or less (39 mA or less at 24 V/72 mA or less at 12 V) ECO ON: 920 mW or less (36 mA or less at 24 V/66 mA or less at 12 V) ECO FULL: 830 mW or less (33 mA or less at 24 V/59 mA or less at 12 V)								
Ambient light	Incandescent lamp: 20,000 lx or less, sunlight: 30,000 lx or less								
Ambient temperature	-20°C to +55°C (no freezing) ⁸								
Vibration resistance	10 to 55 Hz; double amplitude 1.5 mm, 2 hours each for X, Y, and Z axes								
Shock resistance	500 m/s ² ; 3 times each for X, Y, and Z axes								
Case material	Main unit and cover: polycarbonate								
Weight	Approx. 79 g	Approx. 48 g	Approx. 83 g	Approx. 73 g	Approx. 25 g	Approx. 23 g			

¹ IO-Link Specification V1, MCOM2 (38.4 kbps) is supported.
² Ensure the cable length is 30 m or less for the MS connector type. In case of connecting with IO-Link, set it to 20 m or less.
³ Output 2 and the external input are selectable.
⁴ This counts as 1 output when connecting multiple units to the FS-MCBNPN, NUI Series.
⁵ The input time becomes 25 ms (ON)/25 ms (OFF) when external calibration input is selected.

⁶ When expanding the system to 9 or more units, use a power supply voltage of 12 V or higher.
⁷ The load current is excluded. The power consumption including the load when the maximum number of units are connected is 38 W max.
⁸ When expanded by 1 to 2 units: -20°C to +55°C. When expanded by 3 to 10 units: -20°C to +50°C. When expanded by 11 to 16 units: -20°C to +45°C. When using 2 outputs, 1 unit is counted as 2 units. Note that all the temperature prescriptions assume that the sensor has been mounted on a DIN rail installed on a metal surface. Exercise special care when installing the product in an airtight space.

WARRANTIES AND DISCLAIMERS

- (1) KEYENCE warrants the Products to be free of defects in materials and workmanship for a period of one (1) year from the date of shipment. If any models or samples were shown to Buyer, such models or samples were used merely to illustrate the general type and quality of the Products and not to represent that the Products would necessarily conform to said models or samples. Any Products found to be defective must be shipped to KEYENCE with all shipping costs paid by Buyer or offered to KEYENCE for inspection and examination. Upon examination by KEYENCE, KEYENCE, at its sole option, will refund the purchase price of, or repair or replace at no charge any Products found to be defective. This warranty does not apply to any defects resulting from any action of Buyer, including but not limited to improper installation, improper interfacing, improper repair, unauthorized modification, misapplication and mishandling, such as exposure to excessive current, heat, condensation, moisture, vibration or outdoors air. Components which wear are not warranted.
- (2) KEYENCE is pleased to offer suggestions on the use of its various Products. They are only suggestions, and it is Buyer's responsibility to ascertain the fitness of the Products for Buyer's intended use. KEYENCE will not be responsible for any damages that may result from the use of the Products.
- (3) The Products and any samples ("Products/Samples") supplied to Buyer are not to be used internally in humans, for human transportation, as safety devices or fail-safe systems, unless their written specifications state otherwise. Should any Products/Samples be used in such a manner or misused in any way, KEYENCE assumes no responsibility, and additionally Buyer will indemnify KEYENCE and hold KEYENCE harmless from any liability or damage whatsoever arising out of any misuse of the Products/Samples.
- (4) OTHER THAN AS STATED HEREIN, THE PRODUCTS/SAMPLES ARE PROVIDED WITH NO OTHER WARRANTIES WHATSOEVER. ALL EXPRESS, IMPLIED, AND STATUTORY WARRANTIES, INCLUDING, WITHOUT LIMITATION, THE WARRANTIES OF MERCHANTABILITY, FITNESS FOR A PARTICULAR PURPOSE, AND NON-INFRINGEMENT OF PROPRIETARY RIGHTS, ARE EXPRESSLY DISCLAIMED. IN NO EVENT SHALL KEYENCE AND ITS AFFILIATED ENTITIES BE LIABLE TO ANY PERSON OR ENTITY FOR ANY DIRECT, INDIRECT, INCIDENTAL, PUNITIVE, SPECIAL OR CONSEQUENTIAL DAMAGES (INCLUDING, WITHOUT LIMITATION, ANY DAMAGES RESULTING FROM LOSS OF USE, BUSINESS INTERRUPTION, LOSS OF INFORMATION, LOSS OR INACCURACY OF DATA, LOSS OF PROFITS, LOSS OF SAVINGS, THE COST OF PROCUREMENT OF SUBSTITUTED GOODS, SERVICES OR TECHNOLOGIES, OR FOR ANY MATTER ARISING OUT OF OR IN CONNECTION WITH THE USE OR INABILITY TO USE THE PRODUCTS, EVEN IF KEYENCE OR ONE OF ITS AFFILIATED ENTITIES WAS ADVISED OF A POSSIBLE THIRD PARTY'S CLAIM FOR DAMAGES OR ANY OTHER CLAIM AGAINST BUYER. In some jurisdictions, some of the foregoing warranty disclaimers or damage limitations may not apply.

BUYER'S TRANSFER OBLIGATIONS:

If the Products/Samples purchased by Buyer are to be resold or delivered to a third party, Buyer must provide such third party with a copy of this document, all specifications, manuals, catalogs, leaflets and written information provided to Buyer pertaining to the Products/Samples.

E 1101-3

6 Detailed Settings

Hold down **[M]** for 3 seconds or more to enter the settings menu. Then, press **[M]** to change the item and press **[← →]** to switch the setting value. Press **[M] + [END]** when an item is being set to return to the previous item.

A Power Modes Press **[← →]** to select the value.

Select from eight power modes. The initial setting is FINE.

Mode	S-HSPD ^{*1}	HSPD	FINE	TURBO
Response time	23 μs	50 μs	250 μs	500 μs
Maximum displayable light intensity	9999			

Mode	SUPER	ULTRA	MEGA	TERA
Response time	1 ms	4 ms	16 ms	64 ms
Maximum displayable light intensity	9999			

B Switch L-on/D-on Press **[← →]** to select the value.

- Light ON
- Dark ON

C Display Bar Press **[← →]** to select the value.

- OFF
- ON

[END] <> ADVANCE Press **[← →]** to select the value.

End **[M]** ADVANCE
Settings complete

D Detection Mode ^{*3} Press **[← →]** to select the value.

Select from the following operation modes.

- Standard
- Preset
- Percent
- Zeroshift
- Area detection
- Area % Mode
- DATUM
- Rising edge
- Falling edge

E Output timer ^{*4} Press **[← →]** to select the value.

F Ext. Input Press **[← →]** to select the value.

This can only be used on types that support an external input. It is possible to select from the following values.

- OFF
- External Set
- Zero shift
- Reset
- LED OFF
- Pause
- Sleep

When connected to the multi-output unit FS-MC8N/P or the communication unit NU Series, this setting can be configured on types that do not support an external input.

G Saturate Cancel Press **[← →]** to select the value.

H Attenuation Press **[← →]** to select the value.

I Zero Shift Press **[← →]** to select the value.

J Limit Detection ^{*4} Press **[← →]** to select the value.

If Limit Detection is set to ON, a notification of a drop in light intensity is shown on the display when the light intensity drops due to factors such as dirt. With dual output types, it is also possible to output alarms to an external device. When connected to the multi-output unit FS-MC8N/P, it is possible to output alarms from the "common output" of the FS-MC8N/P even for types that do not support the alarm output.

K Auto Power Press **[← →]** to select the value.

L Hysteresis Press **[← →]** to select the value.

M Language Press **[← →]** to select the value.

Select from English (initial setting), Japanese, Chinese, and German.

N Flip Display Press **[← →]** to select the value.

O Sub Display Press **[← →]** to select the value.

P ACT-R Press **[← →]** to select the value.

Q Brightness Press **[← →]** to select the value.

R ECO ^{*5} Press **[← →]** to select the value.

S Initialize Press **[← →]** to select the value.

T Custom Setting Press **[← →]** to select the value.

U Interference ^{*5} ^{*7} Press **[← →]** to select the value.

V Key Lock Method Press **[← →]** to select the value.

W Display Gain ^{*5} Press **[← →]** to select the value.

X IO-Link Mode ^{*8} Press **[← →]** to select the value.

Y IO Data Format ^{*8} Press **[← →]** to select the value.

Z I/O Selection ^{*8} Press **[← →]** to select the value.

Settings complete

Output 2 setting

1 **2** When using a dual output type, if the output channel selection switch is set to the "2" side, output 2 can be set.

Hold down **[M]** for 3 seconds or more to enter setup mode.

a Second Output Press **[← →]** to select the value.

b Switch L-On/D-On Press **[← →]** to select the value.

c Output timer 2 Press **[← →]** to select the value.

Settings complete

^{*1} When S-HSPD is selected for Power Modes Output 2 of dual output types is fixed to OFF.
^{*2} This is 65535 when connected to an NU Series unit.
^{*3} When S-HSPD is selected for Power Modes Area detection, Area % Mode, DATUM, Rising edge, or Falling edge cannot be selected.
^{*4} This cannot be used when S-HSPD is selected for Power Modes.
^{*5} This cannot be used when S-HSPD or HSPD is selected for Power Modes.
^{*6} When S-HSPD is selected for Power Modes, FULL cannot be selected for the ECO function. The IO-Link communication cannot be used when FULL is selected for ECO (FS-N41C).
^{*7} This item is not displayed on the FS-N41C.
^{*8} This item is only displayed on the FS-N41C.

KEYENCE CORPORATION
 1-3-14, Higashi-Nakajima, Higashi-Yodogawa-ku,
 Osaka, 533-8555, Japan
 PHONE: +81-6-6379-2211 www.keyence.com

AUSTRIA Ph: +43 22 36-3782 66-0	HONG KONG Ph: +852-3104-1010	NETHERLANDS Ph: +31 40 20 66 100	TAIWAN Ph: +886-2-2721-8080
BELGIUM Ph: +32 1 528 1222	HUNGARY Ph: +36 1 802 73 60	PHILIPPINES Ph: +63-(0)2-981-5000	THAILAND Ph: +66-2-369-2777
BRAZIL Ph: +55-11-3045-4011	INDIA Ph: +91-44-4963-0900	POLAND Ph: +48 71 36861 60	UK & IRELAND Ph: +44-1908-696900
CANADA Ph: +1-905-366-7655	INDONESIA Ph: +62-21-2966-0120	ROMANIA Ph: +40 269-232-808	USA Ph: +1-201-930-0100
CHINA Ph: +86-21-3357-1001	ITALY Ph: +39-02-6688220	SINGAPORE Ph: +65-6392-1011	VIETNAM Ph: +84-24-3772-5555
CZECH REPUBLIC Ph: +420 222 191 483	KOREA Ph: +82-31-789-4300	SLOVAKIA Ph: +421 2 5939 6461	
FRANCE Ph: +33 1 56 37 78 00	MALAYSIA Ph: +60-3-7883-2211	SLOVENIA Ph: +386 1-4701-666	
GERMANY Ph: +49 6102 36 89-0	MEXICO Ph: +52-55-8850-0100	SWITZERLAND Ph: +41 43-45577 30	

ASSEMBLY TITLE: BROKEN WEB / END OF WEB

DRAWING NO:

GENERAL FUNCTION:

- The broken web fault indicates that the labeler label stock has broken after the labeler pull roll. It consists of a reflective sensor and a reflector. The sensor is capable of reading clear or opaque label liner.

-When the broken web passes through the sensor, a signal is generated, that signal will shut the conveyor system down and light the red lamp on the stack lamp assembly.

-To reset the fault condition, rethread labels and press labeler run/pause to turn off the red light and place the labeler in run mode. The conveyor will restart and the labeling process will continue.

SET-UP AND ADJUSTMENTS:

- The sensor is set in light on operation mode. It is a retro-reflective operation. To set the sensor, refer to the following manufacture's instruction sheet.

- Ensure that all label material is removed from the sensor and reflector area for proper set up.

MAINTENANCE:

- See Maintenance Section

TROUBLESHOOTING:

- See Troubleshooting Section

ITEM	QTY	PART NO.	DESCRIPTION	PARENT ITEM
1	1	202192-002	CLEAR PRODUCT SENSOR	21606-013
2	1	203161-000	REFLECTOR	21606-013
3	1	252019-000	4 PIN MALE CONNECTOR	21606-013
4	1	A24241-000	MOUNTING BLOCK	21606-013
5	1	A24242-000	SENSOR MTG. BLOCK	21606-013
6	1	A24243-000	REFLECTOR MTG. BLOCK	21606-013
7	2	A24244-000	SUPPORT ROD WITH FLAT	21606-013

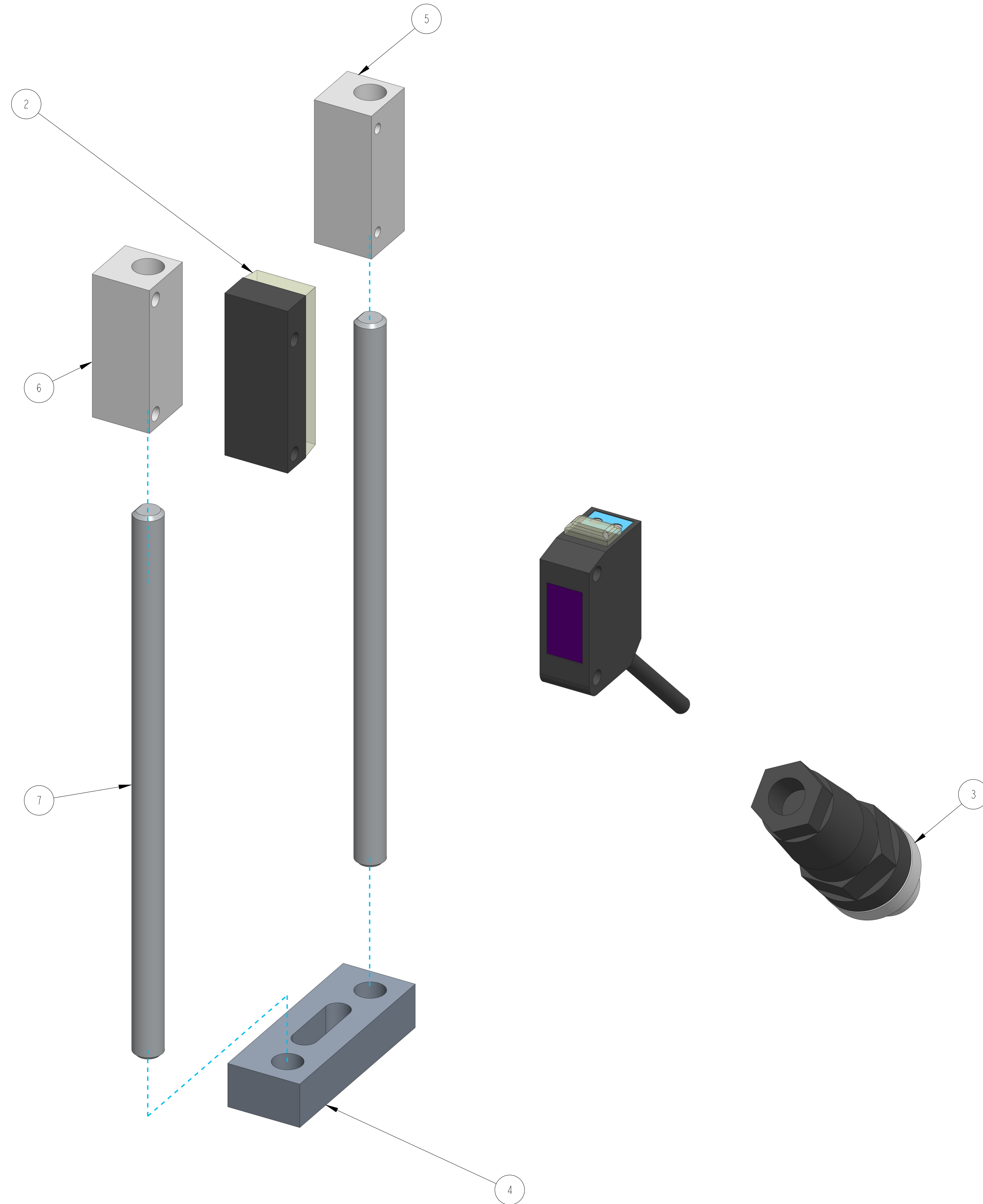

REV	DATE	DESCRIPTION	BY
A	11/11/24	NEW DRAWING	SEM

THIS IS A PRO-ENGINEER DOCUMENT AND MAY NOT BE MODIFIED MANUALLY

UNLESS OTHERWISE SPECIFIED DIMENSIONAL TOLERANCE	QUADREL LABELING SYSTEMS 7670 JENTHER DRIVE MENTOR, OHIO 44060 (440) 602-4700	SCALE: 2/1 DATE: 11/11/24 DRW BY: SEM CHK BY: &CREO_CHK APPR BY:
.1 .01 .005 ANGLES ± 30°	BROKEN WEB/END OF WEB, PNP SINGLE BASE, USE PZ-G62P	MAT'L 21606-013

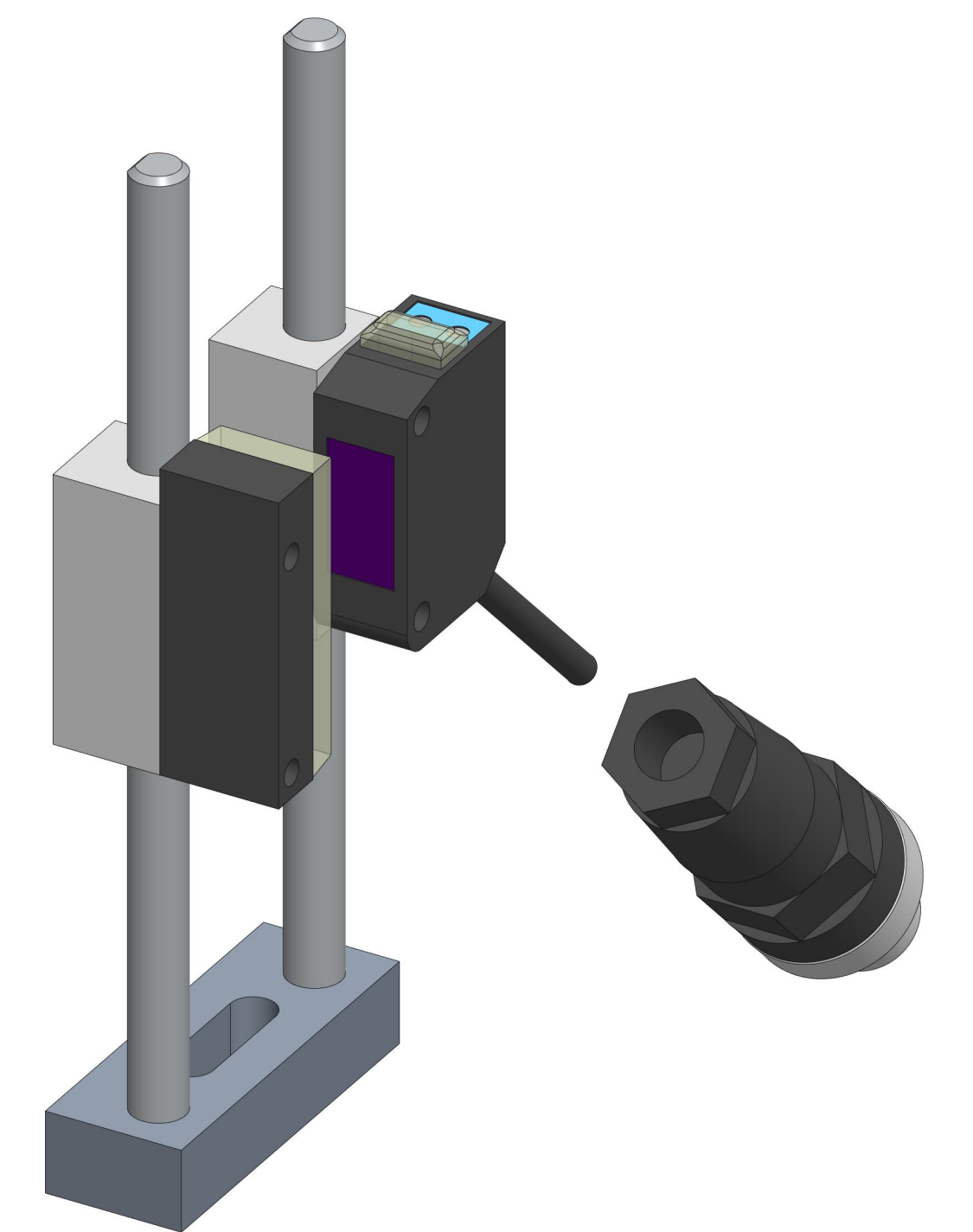
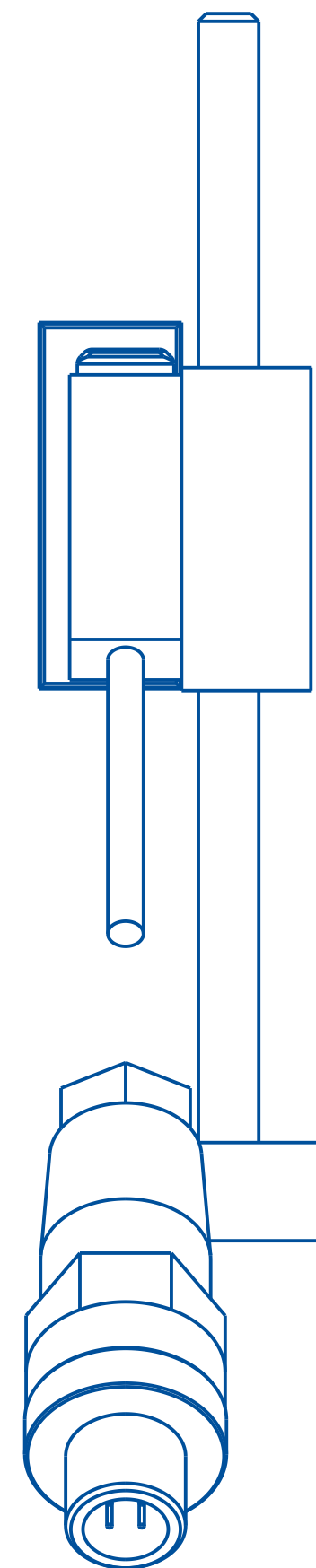
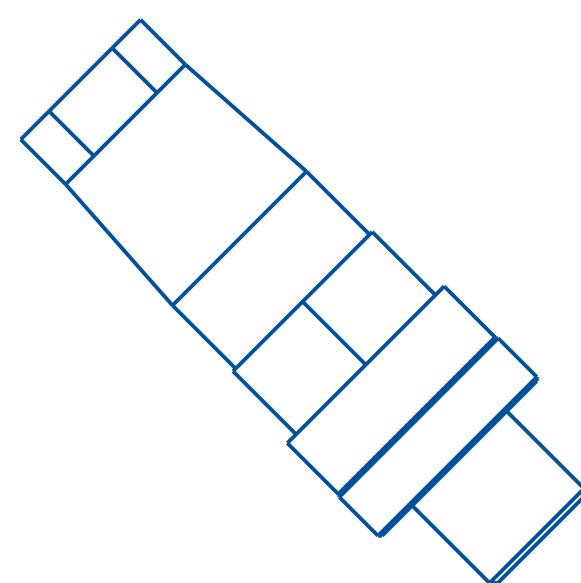
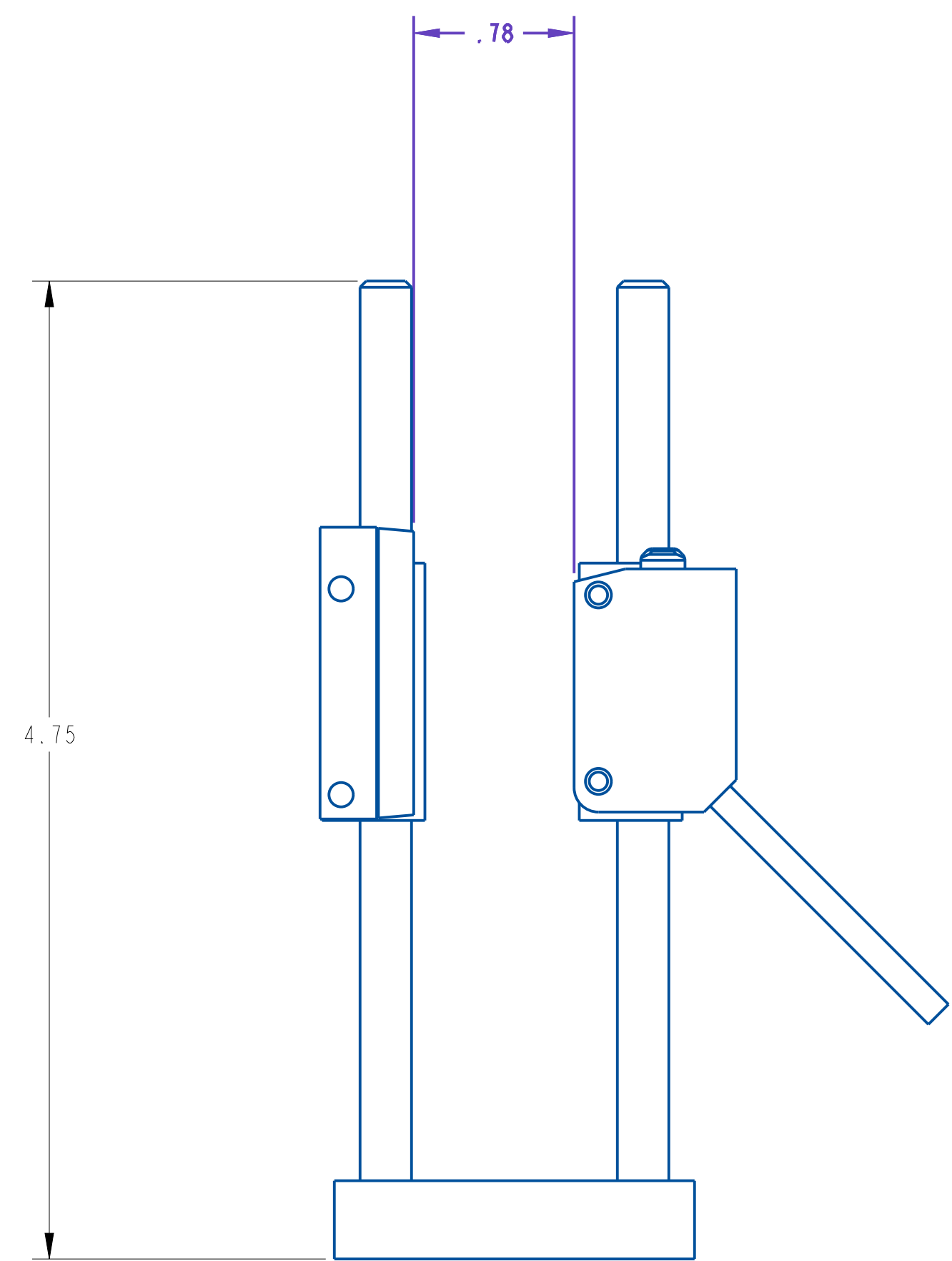
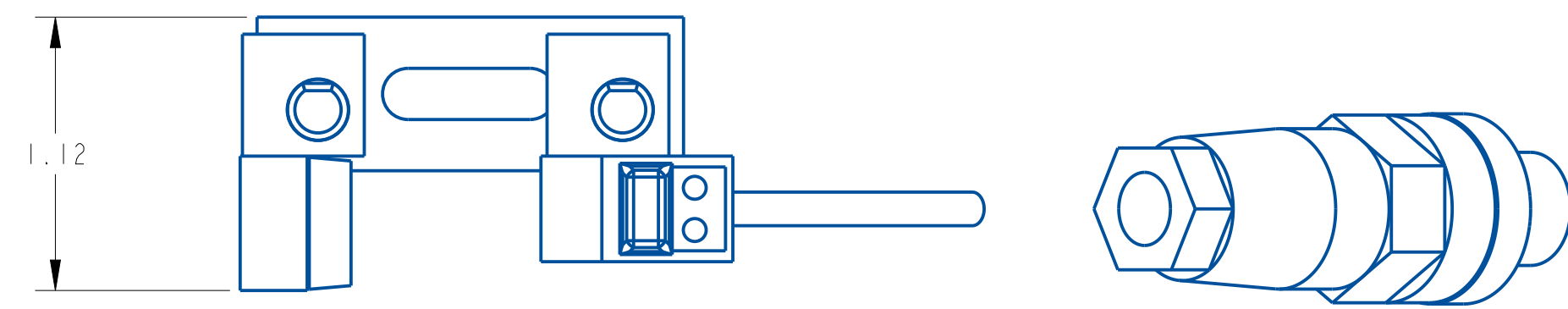

REV	DATE	DESCRIPTION	BY
A	11/11/24	NEW DRAWING	SEM

THIS IS A PRO-ENGINEER DOCUMENT AND MAY NOT BE MODIFIED MANUALLY

UNLESS OTHERWISE SPECIFIED
DIMENSIONAL TOLERANCE
X ± .1
XX ± .01
XXX ± .005
ANGLES ± .30°

SURFACE FINISH 125
BREAK ALL EDGES .005/ .015
CORNER RADIUS .010/ .030
ALL ANGLES ARE 90°

QUADREL LABELING SYSTEMS
7670 JENTHER DRIVE
MENTOR, OHIO 44060
(440) 602-4700

BROKEN WEB/END OF WEB, PNP SINGLE BASE, USE PZ-G62P

MAT'L - 21606-013

PZ-G Series

Instruction Manual

Read this manual thoroughly before using the product.
Keep this manual readily available for future reference.

96M11227



Safety precautions

- Avoid running the PZ-G cable along with power and high voltage lines, as this may cause interference and/or permanent damage.
- When using a commercially available switching regulator, ground its chassis grounding and earth grounding terminals.
- Do not use in locations where direct ambient light or external light directly shines on the light receiving surface.
- With retro-reflective type sensors, when detecting highly reflective materials (such as mirrored surfaces), stabilization may be difficult. To correct this, change the angle of the sensor head, or adjust the sensitivity.
- Avoid using power which exceeds the specifications for ripple (10% max)
- Avoid using excess force when rotating the operation mode selector switch (Light-on, Dark-on) and the sensitivity adjustment trimmer.
- This product is just intended to detect the object(s). Do not use this product for the purpose to protect a human body or a part of human body.
- This product is not intended for use as explosion-proof product. Do not use this product in a hazardous location and/or potentially explosive atmosphere.

Precautions on Regulations and Standards

UL Certificate

This product is an UL/C-UL Listed product.

- UL File No. E301717
- Category NRKH,NRKH7
- Enclosure Type 1 (Based on UL50)

Be sure to consider the following specifications when using this product as an UL/C-UL Listed Product.

- Use the power supply with Class 2 output defined in NFPA70 (NEC: National Electrical Code).
- Power supply/ Control input/ Control output circuits shall be connected to a single Class 2 source only.
- Use with the over current protection device which is rated 30V or more and not more than 1A.

Part Names

PZ-G5xN/G5xP

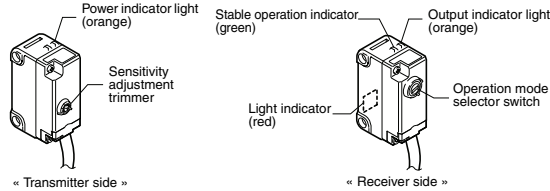

PZ-G5xB

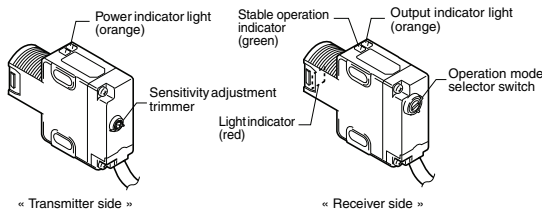

PZ-G4xN/G4xP/G10xN/G10xP/G6xN/G6xP

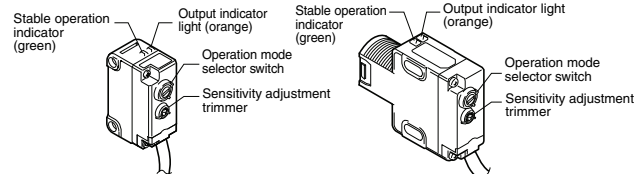

* The model name with "C" (PZ-GxxCx) is the connector type, and the model name with "E" (PZ-GxxEx) is the pigtail quick disconnect type.

Mounting Method

Side Mounting (Prepare M3 screws)

Tightening torque: 0.5 N·m or less

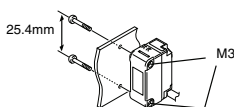

Tightening torque: 0.5 N·m or less

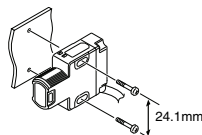

Mounting with the M18 nut (includes nut type)

The M18 nut is also available separately as OP-84225 (2 pcs. supplied).
Tightening torque: 1.0 N·m or less

Panel (5 mm or less)

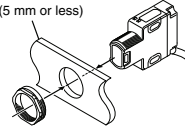

Panel cut size

φ18.5 ± 0.2 mm

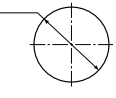

Note

- Mount the M18 nut (supplied) straight in. If mounted at an angle it cannot be tightened properly.
- When tightening the M18 nut (supplied), firmly hold the main body down. The case of the main body may be damaged if held in place with a tool such as pliers.
- When tightening the M18 nut (supplied), if excess force is applied to the nut with a tool such as pliers, it may bend it out of shape. Therefore, do not apply excess force.

Sensitivity Adjustment Method

Caution



Avoid using excess force when rotating the sensitivity adjustment trimmer and operation mode selector switch as it may cause damage.

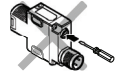

Operation mode selector switch

With the operation mode selector switch, you can select either the LIGHT-ON mode (L) or the DARK-ON (D) mode.



Reflective type (PZ-G41/G42/G101/G102/G10R/G10G/G10B Series)

The following assumes LIGHT-ON (L) is set.

Sequence	Adjustment method	Sensitivity adjustment trimmer
①	Position target in place. Slowly rotate the sensitivity trimmer from the MIN position towards the MAX position until the (orange) output indicator turns on (Position "A"). If the output indicator does not turn off, even at MIN, then MIN is considered Position "A".	A
②	Remove the target. Adjust the sensitivity trimmer from MIN towards MAX until the (orange) output indicator turns on (Position "B"). If the output indicator does not light up, the MAX position is considered Position "B".	B
③	Adjust the sensitivity trimmer to the midpoint between "A" and "B". Verify that the (green) stable operation light turns on with and without a target in place.	A B

Reference To use the sensor in DARK-ON mode, adjust the mode selector switch to "D".

Thrubeam type (PZ-G51/G52 Series) / Retro-reflective type (PZ-G61/G62 Series)

The following assumes DARK-ON (D) is set.

Sequence	Adjustment method	Sensitivity adjustment trimmer
①	Remove the target. Adjust the sensitivity trimmer to MAX. Mount the sensor heads in place so the (orange) output indicator turns off (on thrubeam models, the red light on the receiver face will turn on)	MIN MAX
②	Position target in place. Verify that the orange output indicator turns on (on thrubeam models, the red light on the receiver face will turn off). Adjust sensitivity lower if the output indicator does not turn on (or if the red light on the receiver face does not turn off on thrubeam models)	

Reference To use the sensor in LIGHT-ON mode, adjust the mode selector switch to "L".

I/O Circuit Diagram

PZ-G5xN/G5xP/G5xB (Transmitter side)

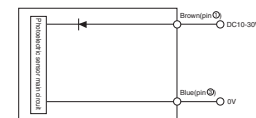

PZ-G5xN (Receiver side)/ G4xN/G10xN/G6xN

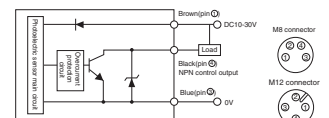

PZ-G5xP (Receiver side)/ G4xP/G10xP/G6xP

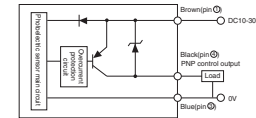

PZ-G5xB (Receiver side)/ G4xB/G10xB/G6xB

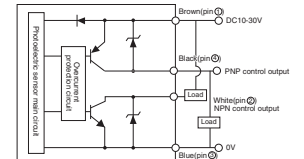

* The pin numbers represent those of the connector type / pigtail quick disconnect type. The model name with "C" (PZ-GxxCx) is the connector type, and the model name with "E" (PZ-GxxEx) is the pigtail quick disconnect type.

[PZ-GxxCN/GxxCP..... M8 connector
PZ-GxxCB/GxxEN/GxxEP..... M12 connector]

Indicators

The following describes each ON/OFF condition of indicator when LIGHT-ON (L) is set.

Reference When the DARK-ON (D) is set, the output indicator ON/OFF will reverse.

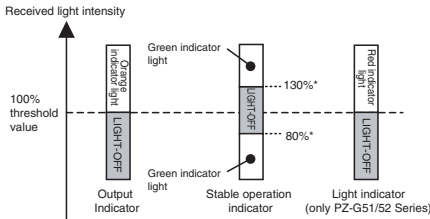

* For PZ-G62, the upper limit is 107% and the lower limit is 93%.

If the stable operation indicator turns off during operation, readjust or fine-adjust the sensitivity.

Mutual interference

- For reflective type / retro-reflective type sensors, mutual interference protection can be set for up to 2 units. However, when the sensors are mounted facing each other, change the angle of the sensor head to prevent light being emitted into each unit. (The mark detection type does not include the mutual interference function.)
- Mutual interference prevention can be set when mounting a polarizing filter attachment (optional with thru-beam type sensors) (If operation is unstable even after mounting the polarizing filter, slightly lower the sensitivity.)
- For more detailed information about mutual interference or attachment, see the PZ-G Series catalog or contact your nearest KEYENCE office.

Specifications

Type		Thru-beam		Reflective				Retro-reflective		Mark detection			
Configuration	Cable shape	Output mode	Normal	High-power	Diffuse-reflective Long-detecting distance	Diffuse-reflective Short-detecting distance	Narrow-view reflective	Definite reflective	Long detecting distance (with P.R.O. function)	Transparent target detection (without P.R.O. function)	Red	Green	Blue
Rectangular	Cable	NPN	PZ-G51N	PZ-G52N	PZ-G41N	PZ-G42N	PZ-G101N	PZ-G102N	PZ-G61N	PZ-G62N			
		PNP	PZ-G51P	PZ-G52P	PZ-G41P	PZ-G42P	PZ-G101P	PZ-G102P	PZ-G61P	PZ-G62P			
	M8 connector	NPN	PZ-G51CN	PZ-G52CN	PZ-G41CN	PZ-G42CN	PZ-G101CN	PZ-G102CN	PZ-G61CN	PZ-G62CN	PZ-G10RCN	PZ-G10GCN	PZ-G10BCN
		PNP	PZ-G51CP	PZ-G52CP	PZ-G41CP	PZ-G42CP	PZ-G101CP	PZ-G102CP	PZ-G61CP	PZ-G62CP	PZ-G10RCP	PZ-G10GCP	PZ-G10BCP
Nut	Cable	NPN	PZ-G51EN	PZ-G52EN	PZ-G41EN	PZ-G42EN	PZ-G101EN	PZ-G102EN	PZ-G61EN	PZ-G62EN			
		PNP	PZ-G51EP	PZ-G52EP	PZ-G41EP	PZ-G42EP	PZ-G101EP	PZ-G102EP	PZ-G61EP	PZ-G62EP			
Nut	M12 connector	Bipolar	PZ-G51B	PZ-G52B	PZ-G41B	PZ-G42B	PZ-G101B	PZ-G102B	PZ-G61B	PZ-G62B			
		(NPN+PNP)	PZ-G51CB	PZ-G52CB	PZ-G41CB	PZ-G42CB	PZ-G101CB	PZ-G102CB	PZ-G61CB	PZ-G62CB			
Detecting distance ¹			20 m	40 m	1 m (30 x 30 cm white mat paper)	300 mm (10 x 10 cm white mat paper)	200 mm	5 to 45 mm	0.1 to 4.2 m (when R-2L reflector is used)	0.1 to 1 m (when R-2L reflector is used)	8 to 15 mm		
Spot diameter			-	-	-	-	Approx. φ 5 mm (when the detecting distance is 100 mm)	Approx. φ 2 mm (when the detecting distance is 40 mm)	-	-	Approx. 1.5 x 4 mm (when the detecting distance is 10 mm)		
Light source (LED)			Red LED	Infrared LED x 2	Red LED				Infrared LED		Red LED	Green LED	Blue LED
Sensitivity adjustment		1-turn trimmer (230 degrees)											
Response time		500 μs										50 μs	
Operation mode		LIGHT-ON/DARK-ON, trimmer-selectable											
Indicator (LED)		Transmitter: power (orange) Receiver: output (orange), stable operation (green), light (red)			Output (orange), stable operation (green)								
Control output		Open-collector 100 mA max. (30 V max.), Residual voltage 1 V max.											
Protection circuit		Reverse-polarity protection, over-current protection, output surge absorber											
Ratings	Power voltage	10 to 30 VDC, Ripple (P-P): ±10% max, Class 2.											
	Current consumption	Transmitter: 20 mA max. Receiver: 28 mA max.	Transmitter: 25 mA max. Receiver: 28 mA max.	34 mA max.									
Environmental resistance	Enclosure rating	IEC/JEM: IP67 / NEMA: 4X,6,12 / DIN: IP69K											
	Ambient light	Incandescent lamp: 5,000 (lx) max, Sunlight: 20,000 (lx) max.											
	Ambient temperature	-20 °C to +55 °C (No freezing)											
	Relative humidity	35 to 85 % RH (No condensation)											
	Vibration resistance	10 to 55 Hz, 1.5 mm double amplitude in X, Y, Z directions, 2 hours each											
Interference prevention		2 units (when polarizing filter attachment is used)		2 units (with the automatic different cycle function)									
	Material	Case, M18 nut (nut type only): reinforced glass polybutylene terephthalate (PBT), Trimmer: reinforced glass polyamide (PA) Cable (Cable type / pigtail quick disconnect type only): Polyvinyl chloride (PVC), Screw (Case connection): Steel, zinc-nickel plated, Packing (Case connection): Nitrile-butadiene rubber (NBR) Connector (pigtail quick disconnect type only): Brass-nickel plated, Polybutylene terephthalate (PBT), Polyvinyl chloride (PVC)											
Tightening torque	Lens cover	Polyarylate (PAR)				Acrylic plastic (PMMA)			Polyarylate (PAR)				
	Accessory ²	Rectangular type (side screw part): 0.5 N·m max. Nut type (front M18 part): 1.0 N·m max., (side slot part): 0.5 N·m max.											
Weight		Instruction manual, M18 nut x 2 (nut thru-beam type), M18 nut x 1 (other nut types)											
		Rectangular cable type: Approx. 60 g (Approx. 50 g for thru-beam transmitter), Rectangular M8 connector type: Approx. 10 g, rectangular M12 pigtail quick disconnect type: Approx. 30 g Nut type cable type: Approx. 65 g (Approx. 55 g for thru-beam transmitter), Nut type M12 connector type: Approx. 15 g											

¹ The detection distance is measured with the maximum sensitivity.

² The cable for the connector type / pigtail quick disconnect type is sold separately. The reflector for the retro-reflective type is sold separately.

WARRANTY

KEYENCE products are strictly factory-inspected. However, in the event of a failure, contact your nearest KEYENCE office with details of the failure.

1. WARRANTY PERIOD

The warranty period shall be for one year from the date that the product has been delivered to the location specified by the purchaser.

2. WARRANTY SCOPE

(1) If a failure attributable to KEYENCE occurs within the abovementioned warranty period, we will repair the product, free of charge. However, the following cases shall be excluded from the warranty scope.

- Any failure resulting from improper conditions, improper environments, improper handling, or improper usage other than described in the instruction manual, the user's manual, or the specifications specifically arranged between the purchaser and KEYENCE.
- Any failure resulting from factors other than a defect of our product, such as the purchaser's equipment or the design of the purchaser's software.
- Any failure resulting from modifications or repairs carried out by any person other than KEYENCE staff.
- Any failure that can certainly be prevented when the expendable part(s) is maintained or replaced correctly as described in the instruction manual, the user's manual, etc.
- Any failure caused by a factor that cannot be foreseen at a scientific/technical level at the time when the product has been shipped from KEYENCE.
- Any disaster such as fire, earthquake, and flood, or any other external factor, such as abnormal voltage, for which we are not liable.

(2) The warranty scope is limited to the extent set forth in item (1), and KEYENCE assumes no liability for any purchaser's secondary damage (damage of equipment, loss of opportunities, loss of profits, etc.) or any other damage resulting from a failure of our product.

3. PRODUCT APPLICABILITY

KEYENCE products are designed and manufactured as general-purpose products for general industries.

Therefore, our products are not intended for the applications below and are not applicable to them. If, however, the purchaser consults with us in advance regarding the employment of our product, understands the specifications, ratings, and performance of the product on their own responsibility, and takes necessary safety measures, the product may be applied. In this case, the warranty scope shall be the same as above.

- Facilities where the product may greatly affect human life or property, such as nuclear power plants, aviation, railroads, ships, motor vehicles, or medical equipment
- Public utilities such as electricity, gas, or water services
- Usage outdoors, under similar conditions or in similar environments

E 1040-1

KEYENCE CORPORATION

1-3-14, Higashi-Nakajima, Higashi-Yodogawa-ku,
Osaka, 533-8555, Japan

PHONE: +81-6-6379-2211 www.keyence.com

Specifications are subject to change without notice.

A7WW1-MAN-0069

Copyright (c) 2010 KEYENCE CORPORATION. All rights reserved.

11227E 1070-1 96M11227J

Printed in Japan



ASSEMBLY TITLE: BROKEN WEB / END OF WEB

DRAWING NO:

GENERAL FUNCTION:

- The broken web fault indicates that the labeler label stock has broken after the labeler pull roll. It consists of a reflective sensor and a reflector. The sensor is capable of reading clear or opaque label liner.

-When the broken web passes through the sensor, a signal is generated, that signal will shut the conveyor system down and light the red lamp on the stack lamp assembly.

-To reset the fault condition, rethread labels and press labeler run/pause to turn off the red light and place the labeler in run mode. The conveyor will restart and the labeling process will continue.

SET-UP AND ADJUSTMENTS:

- The sensor is set in light on operation mode. It is a retro-reflective operation. To set the sensor, refer to the following manufacture's instruction sheet.

- Ensure that all label material is removed from the sensor and reflector area for proper set up.

MAINTENANCE:

- See Maintenance Section

TROUBLESHOOTING:

- See Troubleshooting Section

ITEM	QTY	PART NO.	DESCRIPTION	PARENT ITEM
1	1	202192-002	CLEAR PRODUCT SENSOR	21606-012
2	1	203161-000	REFLECTOR	21606-012
3	1	252019-000	4 PIN MALE CONNECTOR	21606-012
4	1	A24242-000	SENSOR MTG. BLOCK	21606-012
5	1	A24243-000	REFLECTOR MTG. BLOCK	21606-012
6	2	A25772-000	POST, SENSOR	21606-012

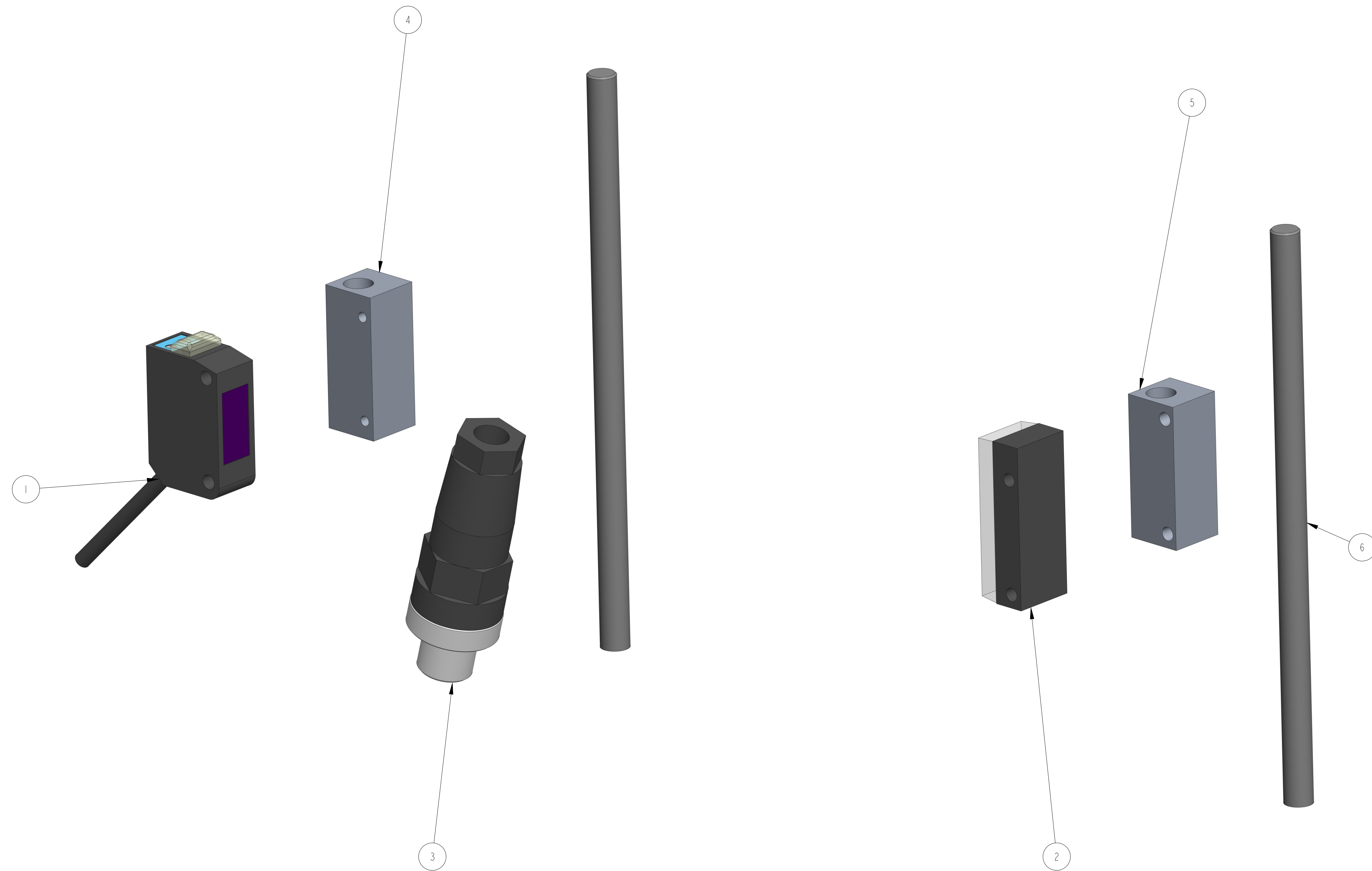

REV	DATE	DESCRIPTION	BY
A	11/11/24	NEW DRAWING	SEM

THIS IS A PRO-ENGINEER DOCUMENT AND MAY NOT BE MODIFIED MANUALLY

UNLESS OTHERWISE SPECIFIED DIMENSIONAL TOLERANCE .XX ± .01 .XXX ± .005 ANGLES ± 30° SURFACE FINISH 125 BREAK ALL EDGES .005/0.15 CORNER RADIUS .010/0.30	QUADREL LABELING SYSTEMS 7670 JENTHER DRIVE MENTOR, OHIO 44060 (440) 602-4700	SCALE: 2/1
		DATE: 11/11/24
		DRW BY: SEM
		CHK BY: CREO_CHK
		APPR BY:
	BROKEN WEB/END OF WEB, PNP DUAL POSTS, USE PZ-G62P	
	MAT'L	21606-012

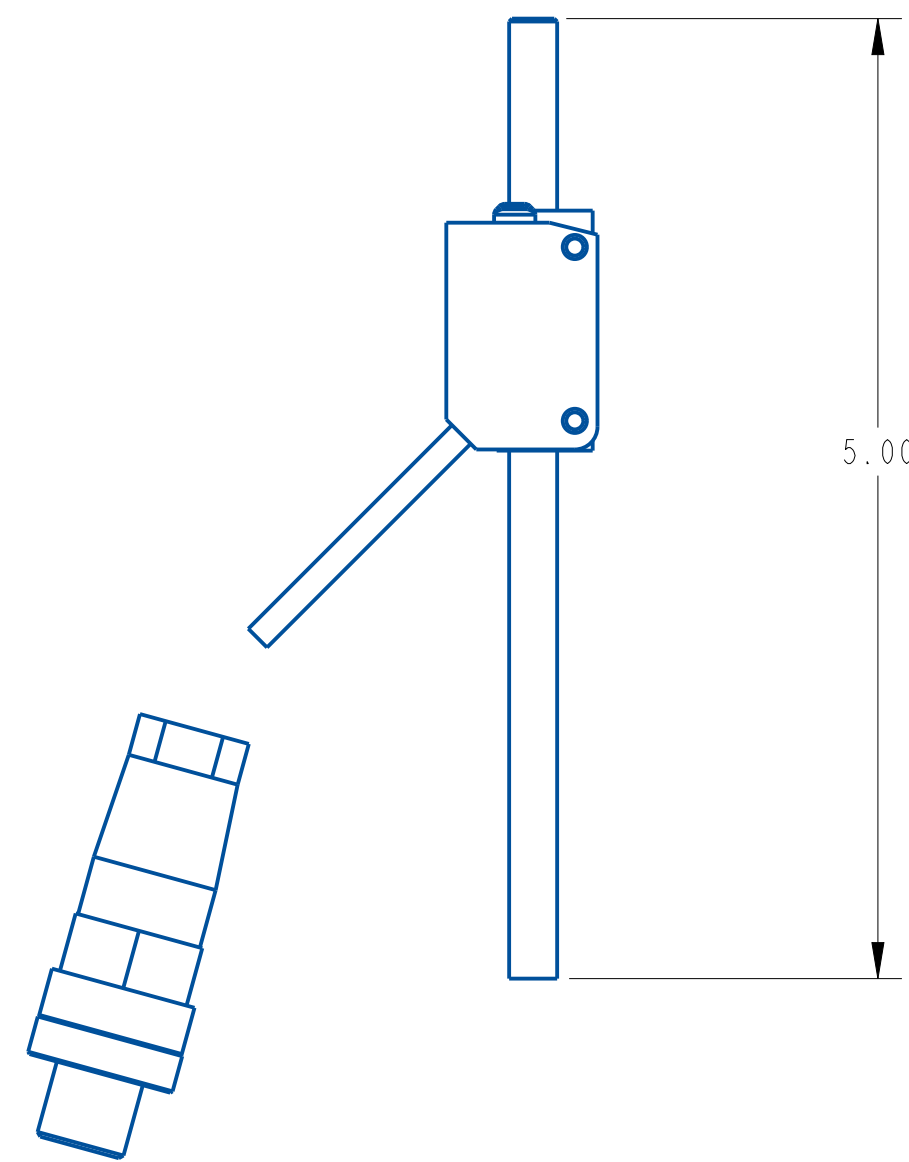
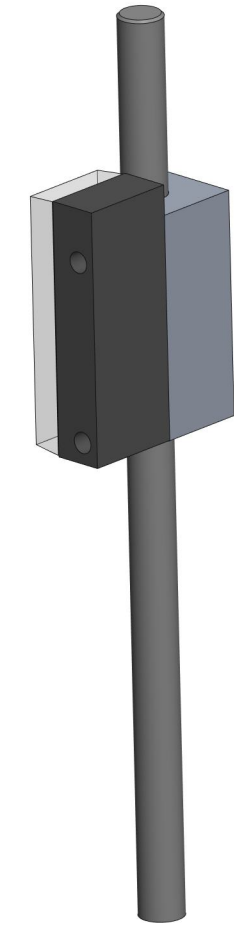
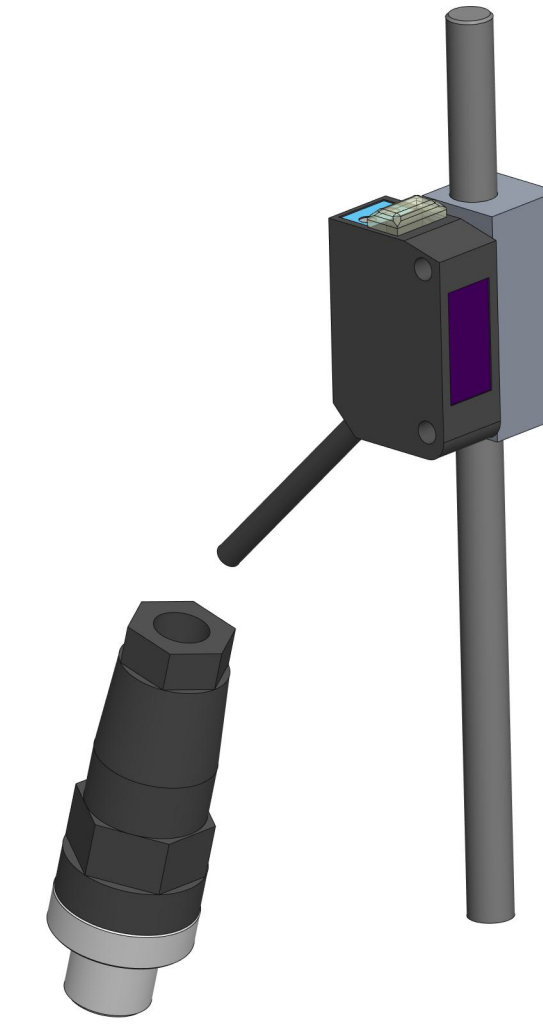
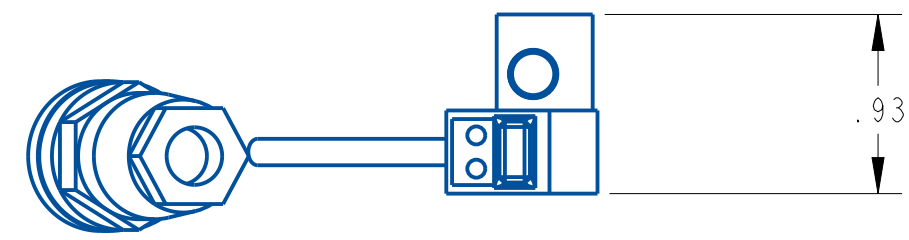

REV	DATE	DESCRIPTION	BY
A	11/11/24	NEW DRAWING	SEM

THIS IS A PRO-ENGINEER DOCUMENT AND MAY NOT BE MODIFIED MANUALLY

UNLESS OTHERWISE SPECIFIED
DIMENSIONAL TOLERANCE
X ± .1
XX ± .01
XXX ± .005
ANGLES ± .30°
SURFACE FINISH 125
BREAK ALL EDGES .005/ .015
CORNER RADIUS .010/ .030
ALL ANGLES ARE 90°

QUADREL LABELING SYSTEMS
7670 JENTHER DRIVE
MENTOR, OHIO 44060
(440) 602-4700

SCALE: 1/1
DATE: 11/11/24
DRW BY: SEM
CHK BY: CREO_CHK
APPR BY:

BROKEN WEB/END OF WEB, PNP DUAL POSTS, USE PZ-G62P

MAT'L

21606-012

PZ-G Series

Instruction Manual

Read this manual thoroughly before using the product.
Keep this manual readily available for future reference.

96M11227



Safety precautions

- Avoid running the PZ-G cable along with power and high voltage lines, as this may cause interference and/or permanent damage.
- When using a commercially available switching regulator, ground its chassis grounding and earth grounding terminals.
- Do not use in locations where direct ambient light or external light directly shines on the light receiving surface.
- With retro-reflective type sensors, when detecting highly reflective materials (such as mirrored surfaces), stabilization may be difficult. To correct this, change the angle of the sensor head, or adjust the sensitivity.
- Avoid using power which exceeds the specifications for ripple (10% max)
- Avoid using excess force when rotating the operation mode selector switch (Light-on, Dark-on) and the sensitivity adjustment trimmer.
- This product is just intended to detect the object(s). Do not use this product for the purpose to protect a human body or a part of human body.
- This product is not intended for use as explosion-proof product. Do not use this product in a hazardous location and/or potentially explosive atmosphere.

Precautions on Regulations and Standards

UL Certificate

This product is an UL/C-UL Listed product.

- UL File No. E301717
- Category NRKH,NRKH7
- Enclosure Type 1 (Based on UL50)

Be sure to consider the following specifications when using this product as an UL/C-UL Listed Product.

- Use the power supply with Class 2 output defined in NFPA70 (NEC: National Electrical Code).
- Power supply/ Control input/ Control output circuits shall be connected to a single Class 2 source only.
- Use with the over current protection device which is rated 30V or more and not more than 1A.

Part Names

PZ-G5xN/G5xP

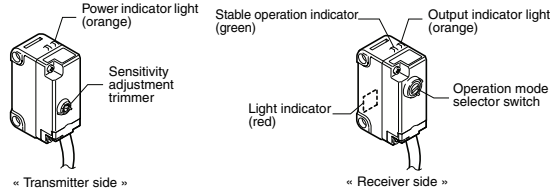

PZ-G5xB

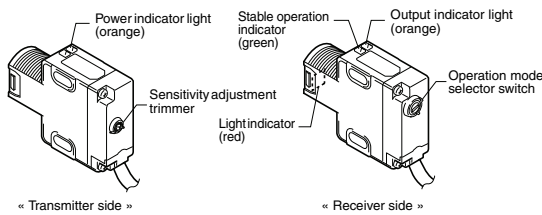

PZ-G4xN/G4xP/G10xN/G10xP/G6xN/G6xP

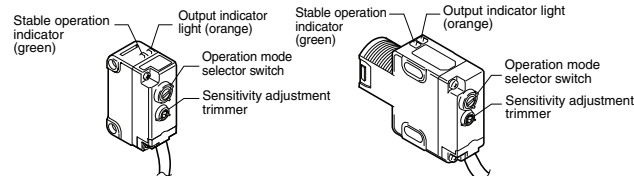

* The model name with "C" (PZ-GxxCx) is the connector type, and the model name with "E" (PZ-GxxEx) is the pigtail quick disconnect type.

Mounting Method

Side Mounting (Prepare M3 screws)

Tightening torque: 0.5 N·m or less

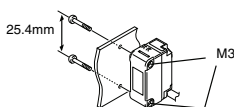

Tightening torque: 0.5 N·m or less

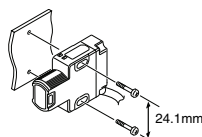

Mounting with the M18 nut (includes nut type)

The M18 nut is also available separately as OP-84225 (2 pcs. supplied).
Tightening torque: 1.0 N·m or less

Panel (5 mm or less)

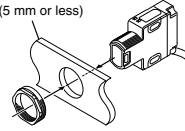

Panel cut size

$\phi 18.5 \pm 0.2$ mm

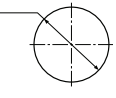

Note

- Mount the M18 nut (supplied) straight in. If mounted at an angle it cannot be tightened properly.
- When tightening the M18 nut (supplied), firmly hold the main body down. The case of the main body may be damaged if held in place with a tool such as pliers.
- When tightening the M18 nut (supplied), if excess force is applied to the nut with a tool such as pliers, it may bend it out of shape. Therefore, do not apply excess force.

Sensitivity Adjustment Method

Caution



Avoid using excess force when rotating the sensitivity adjustment trimmer and operation mode selector switch as it may cause damage.

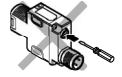

Operation mode selector switch

With the operation mode selector switch, you can select either the LIGHT-ON mode (L) or the DARK-ON (D) mode.



Reflective type (PZ-G41/G42/G101/G102/G10R/G10G/G10B Series)

The following assumes LIGHT-ON (L) is set.

Sequence	Adjustment method	Sensitivity adjustment trimmer
①	Position target in place. Slowly rotate the sensitivity trimmer from the MIN position towards the MAX position until the (orange) output indicator turns on (Position "A"). If the output indicator does not turn off, even at MIN, then MIN is considered Position "A".	
②	Remove the target. Adjust the sensitivity trimmer from MIN towards MAX until the (orange) output indicator turns on (Position "B"). If the output indicator does not light up, the MAX position is considered Position "B".	
③	Adjust the sensitivity trimmer to the midpoint between "A" and "B". Verify that the (green) stable operation light turns on with and without a target in place.	

Reference To use the sensor in DARK-ON mode, adjust the mode selector switch to "D".

Thrubeam type (PZ-G51/G52 Series) / Retro-reflective type (PZ-G61/G62 Series)

The following assumes DARK-ON (D) is set.

Sequence	Adjustment method	Sensitivity adjustment trimmer
①	Remove the target. Adjust the sensitivity trimmer to MAX. Mount the sensor heads in place so the (orange) output indicator turns off (on thrubeam models, the red light on the receiver face will turn on)	
②	Position target in place. Verify that the orange output indicator turns on (on thrubeam models, the red light on the receiver face will turn off). Adjust sensitivity lower if the output indicator does not turn on (or if the red light on the receiver face does not turn off on thrubeam models)	

Reference To use the sensor in LIGHT-ON mode, adjust the mode selector switch to "L".

I/O Circuit Diagram

PZ-G5xN/G5xP/G5xB (Transmitter side)

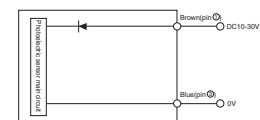

PZ-G5xN (Receiver side)/ G4xN/G10xN/G6xN

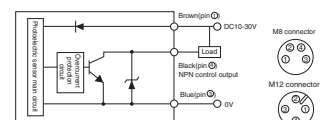

PZ-G5xP (Receiver side)/ G4xP/G10xP/G6xP

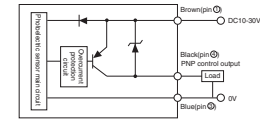

PZ-G5xB (Receiver side)/ G4xB/G10xB/G6xB

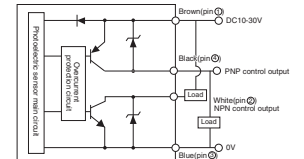

* The pin numbers represent those of the connector type / pigtail quick disconnect type. The model name with "C" (PZ-GxxCx) is the connector type, and the model name with "E" (PZ-GxxEx) is the pigtail quick disconnect type.

[PZ-GxxCN/GxxCP..... M8 connector
PZ-GxxCB/GxxEN/GxxEP..... M12 connector]

Indicators

The following describes each ON/OFF condition of indicator when LIGHT-ON (L) is set.

Reference When the DARK-ON (D) is set, the output indicator ON/OFF will reverse.

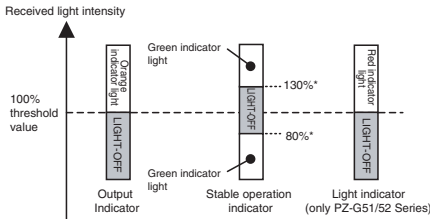

* For PZ-G62, the upper limit is 107% and the lower limit is 93%.
If the stable operation indicator turns off during operation, readjust or fine-adjust the sensitivity.

Mutual interference

- For reflective type / retro-reflective type sensors, mutual interference protection can be set for up to 2 units. However, when the sensors are mounted facing each other, change the angle of the sensor head to prevent light being emitted into each unit. (The mark detection type does not include the mutual interference function.)
- Mutual interference prevention can be set when mounting a polarizing filter attachment (optional with thru-beam type sensors) (If operation is unstable even after mounting the polarizing filter, slightly lower the sensitivity.)
- For more detailed information about mutual interference or attachment, see the PZ-G Series catalog or contact your nearest KEYENCE office.

Specifications

Type		Thru-beam		Reflective				Retro-reflective		Mark detection				
Configuration	Cable shape	Output mode	Normal	High-power	Diffuse-reflective Long-detecting distance	Diffuse-reflective Short-detecting distance	Narrow-view reflective	Definite reflective	Long detecting distance (with P.R.O. function)	Transparent target detection (without P.R.O. function)	Red	Green	Blue	
Rectangular	Cable	NPN	PZ-G51N	PZ-G52N	PZ-G41N	PZ-G42N	PZ-G101N	PZ-G102N	PZ-G61N	PZ-G62N				
		PNP	PZ-G51P	PZ-G52P	PZ-G41P	PZ-G42P	PZ-G101P	PZ-G102P	PZ-G61P	PZ-G62P				
	M8 connector	NPN	PZ-G51CN	PZ-G52CN	PZ-G41CN	PZ-G42CN	PZ-G101CN	PZ-G102CN	PZ-G61CN	PZ-G62CN	PZ-G10RCN	PZ-G10GCN	PZ-G10BCN	
		PNP	PZ-G51CP	PZ-G52CP	PZ-G41CP	PZ-G42CP	PZ-G101CP	PZ-G102CP	PZ-G61CP	PZ-G62CP	PZ-G10RCP	PZ-G10GCP	PZ-G10BCP	
Nut	Cable	NPN	PZ-G51EN	PZ-G52EN	PZ-G41EN	PZ-G42EN	PZ-G101EN	PZ-G102EN	PZ-G61EN	PZ-G62EN				
		PNP	PZ-G51EP	PZ-G52EP	PZ-G41EP	PZ-G42EP	PZ-G101EP	PZ-G102EP	PZ-G61EP	PZ-G62EP				
Nut	M12 connector	Bipolar	PZ-G51B	PZ-G52B	PZ-G41B	PZ-G42B	PZ-G101B	PZ-G102B	PZ-G61B	PZ-G62B				
		(NPN+PNP)	PZ-G51CB	PZ-G52CB	PZ-G41CB	PZ-G42CB	PZ-G101CB	PZ-G102CB	PZ-G61CB	PZ-G62CB				
Detecting distance ¹			20 m	40 m	1 m (30 x 30 cm white mat paper)	300 mm (10 x 10 cm white mat paper)	200 mm	5 to 45 mm	0.1 to 4.2 m (when R-2L reflector is used)	0.1 to 1 m (when R-2L reflector is used)	8 to 15 mm			
Spot diameter			-	-	-	-	Approx. φ 5 mm (when the detecting distance is 100 mm)	Approx. φ 2 mm (when the detecting distance is 40 mm)	-	-	Approx. 1.5 x 4 mm (when the detecting distance is 10 mm)			
Light source (LED)			Red LED	Infrared LED x 2	Red LED				Infrared LED		Red LED	Green LED	Blue LED	
Sensitivity adjustment		1-turn trimmer (230 degrees)												
Response time		500 μs										50 μs		
Operation mode		LIGHT-ON/DARK-ON, trimmer-selectable												
Indicator (LED)		Transmitter: power (orange) Receiver: output (orange), stable operation (green), light (red)			Output (orange), stable operation (green)									
Control output		Open-collector 100 mA max. (30 V max.), Residual voltage 1 V max.												
Protection circuit		Reverse-polarity protection, over-current protection, output surge absorber												
Ratings	Power voltage	10 to 30 VDC, Ripple (P-P): ±10% max, Class 2.												
	Current consumption	Transmitter: 20 mA max. Receiver: 28 mA max.	Transmitter: 25 mA max. Receiver: 28 mA max.	34 mA max.										
Environmental resistance	Enclosure rating	IEC/JEM: IP67 / NEMA: 4X, 6, 12 / DIN: IP69K												
	Ambient light	Incandescent lamp: 5,000 (lx) max, Sunlight: 20,000 (lx) max.												
	Ambient temperature	-20 °C to +55 °C (No freezing)												
	Relative humidity	35 to 85 % RH (No condensation)												
	Vibration resistance	10 to 55 Hz, 1.5 mm double amplitude in X, Y, Z directions, 2 hours each												
Shock resistance	1000 m/s ² in X, Y, Z directions, 6 times each													
Interference prevention		2 units (when polarizing filter attachment is used)		2 units (with the automatic different cycle function)										
Material		Case, M18 nut (nut type only): reinforced glass polybutylene terephthalate (PBT), Trimmer: reinforced glass polyamide (PA) Cable (Cable type / pigtail quick disconnect type only): Polyvinyl chloride (PVC), Screw (Case connection): Steel, zinc-nickel plated, Packing (Case connection): Nitrile-butadiene rubber (NBR) Connector (pigtail quick disconnect type only): Brass-nickel plated, Polybutylene terephthalate (PBT), Polyvinyl chloride (PVC)												
Lens cover		Polyarylate (PAR)				Acrylic plastic (PMMA)			Polyarylate (PAR)					
Tightening torque		Rectangular type (side screw part): 0.5 N·m max. Nut type (front M18 part): 1.0 N·m max., (side slot part): 0.5 N·m max.												
Accessory ²		Instruction manual, M18 nut x 2 (nut thru-beam type), M18 nut x 1 (other nut types)												
Weight		Rectangular cable type: Approx. 60 g (Approx. 50 g for thru-beam transmitter), Rectangular M8 connector type: Approx. 10 g, rectangular M12 pigtail quick disconnect type: Approx. 30 g Nut type cable type: Approx. 65 g (Approx. 55 g for thru-beam transmitter), Nut type M12 connector type: Approx. 15 g												

¹ The detection distance is measured with the maximum sensitivity.

² The cable for the connector type / pigtail quick disconnect type is sold separately. The reflector for the retro-reflective type is sold separately.

WARRANTY

KEYENCE products are strictly factory-inspected. However, in the event of a failure, contact your nearest KEYENCE office with details of the failure.

1. WARRANTY PERIOD

The warranty period shall be for one year from the date that the product has been delivered to the location specified by the purchaser.

2. WARRANTY SCOPE

(1) If a failure attributable to KEYENCE occurs within the abovementioned warranty period, we will repair the product, free of charge. However, the following cases shall be excluded from the warranty scope.

- Any failure resulting from improper conditions, improper environments, improper handling, or improper usage other than described in the instruction manual, the user's manual, or the specifications specifically arranged between the purchaser and KEYENCE.
- Any failure resulting from factors other than a defect of our product, such as the purchaser's equipment or the design of the purchaser's software.
- Any failure resulting from modifications or repairs carried out by any person other than KEYENCE staff.
- Any failure that can certainly be prevented when the expendable part(s) is maintained or replaced correctly as described in the instruction manual, the user's manual, etc.
- Any failure caused by a factor that cannot be foreseen at a scientific/technical level at the time when the product has been shipped from KEYENCE.
- Any disaster such as fire, earthquake, and flood, or any other external factor, such as abnormal voltage, for which we are not liable.

(2) The warranty scope is limited to the extent set forth in item (1), and KEYENCE assumes no liability for any purchaser's secondary damage (damage of equipment, loss of opportunities, loss of profits, etc.) or any other damage resulting from a failure of our product.

3. PRODUCT APPLICABILITY

KEYENCE products are designed and manufactured as general-purpose products for general industries.

Therefore, our products are not intended for the applications below and are not applicable to them. If, however, the purchaser consults with us in advance regarding the employment of our product, understands the specifications, ratings, and performance of the product on their own responsibility, and takes necessary safety measures, the product may be applied. In this case, the warranty scope shall be the same as above.

- Facilities where the product may greatly affect human life or property, such as nuclear power plants, aviation, railroads, ships, motor vehicles, or medical equipment
- Public utilities such as electricity, gas, or water services
- Usage outdoors, under similar conditions or in similar environments

E 1040-1

KEYENCE CORPORATION

1-3-14, Higashi-Nakajima, Higashi-Yodogawa-ku,
Osaka, 533-8555, Japan

PHONE: +81-6-6379-2211 www.keyence.com

Specifications are subject to change without notice.

A7WW1-MAN-0069

Copyright (c) 2010 KEYENCE CORPORATION. All rights reserved.

11227E 1070-1 96M11227J

Printed in Japan



ASSEMBLY TITLE: PRODUCT DETECT ASSEMBLY

DRAWING NO:

GENERAL FUNCTION:

The product detect signal is used to trigger the labeling cycle. Optimum placement and setup of the product detect sensor is critical to accurate and repeatable label placement.

SETUP AND ADJUSTMENTS:

Set the position of the product detect sensor at a point up-stream of the peel plate area. Set the vertical position of the sensor at a point on the product that provides a stable and repeatable sense area. Loosen the vertical adjustment knobs to move the assembly along the vertical axis.

Follow the manufactures data sheet for a particular set and calibration.

MAINTENANCE:

No scheduled maintenance is required for this assembly. Always keep the drive areas free of label flash and debris.

CAUTION: Before performing any maintenance or cleaning make sure the system is powered down.

TROUBLESHOOTING:

PROBLEM:

- No label trigger or intermittent trigger.

WHAT TO DO:

- Product does not intersect sensor scan field. Adjust sensor position until sensor detects product.
- Sensor gain set is too low. Increase gain until sensor indicator displays ON status(with product in sensor field).

ITEM	QTY	PART NO.	DESCRIPTION	PARENT ITEM
1	1	202099-001	REFLECTOR MOUNT	21679-009
2	1	202192-002	CLEAR PRODUCT SENSOR	21679-009
3	1	203005-001	PRODUCT DETECT	21679-009
4	1	203160-000	REFLECTOR	21679-009
5	1	252019-000	4 PIN MALE CONNECTOR	21679-009

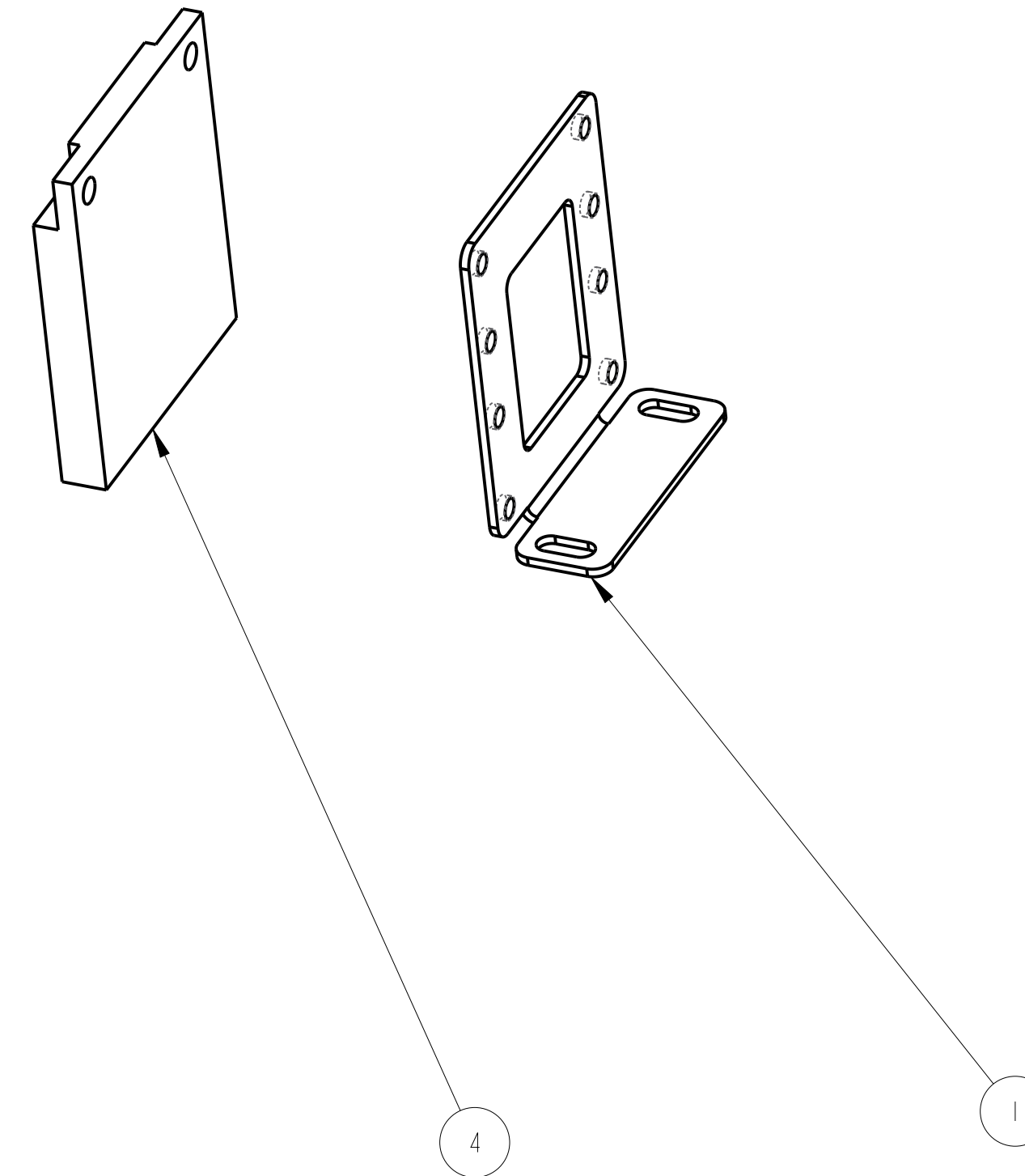
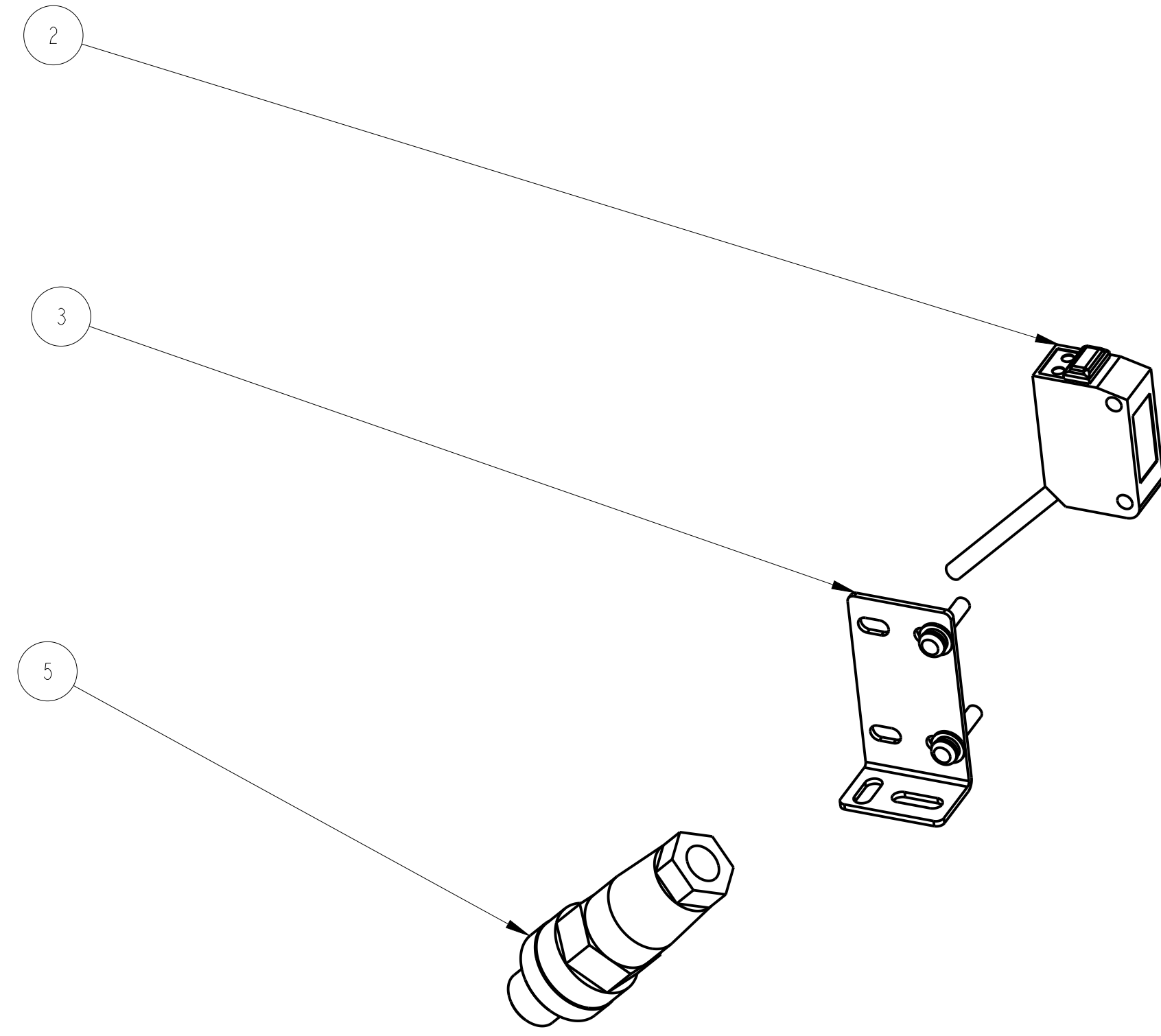

REV	DATE	DESCRIPTION	BY
A	11-16-22	NEW DRAWING	ATT

THIS IS A PRO-ENGINEER DOCUMENT AND MAY NOT BE MODIFIED MANUALLY

QUADREL LABELING SYSTEMS
7670 JENTHER DRIVE
MENTOR, OHIO 44060
(440) 602-4700

SCALE: 1/1
DATE: 11-16-22
DRAWN BY: ATT

PRODUCT DETECT, HUGGER MOUNT

MAT'L	21679-009	21679-009
-------	-----------	-----------

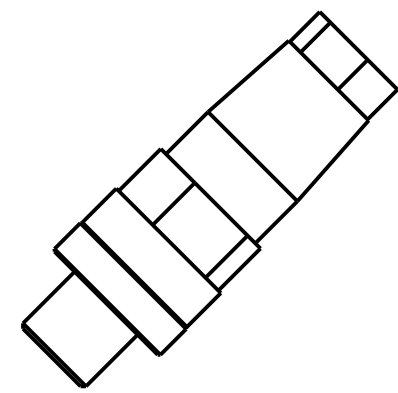
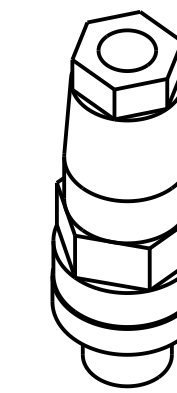
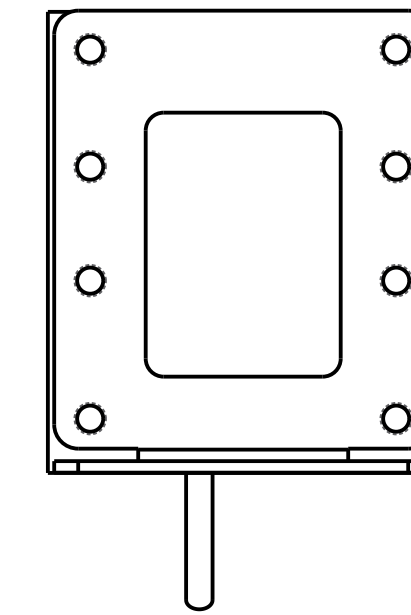
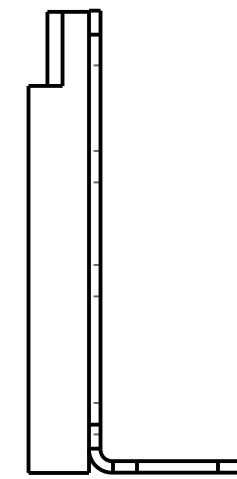
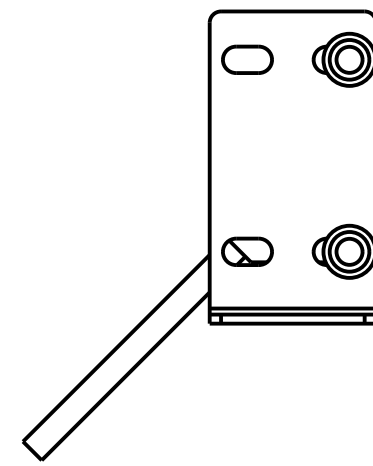
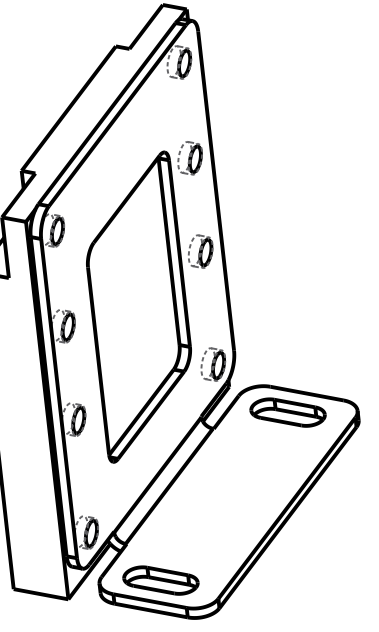
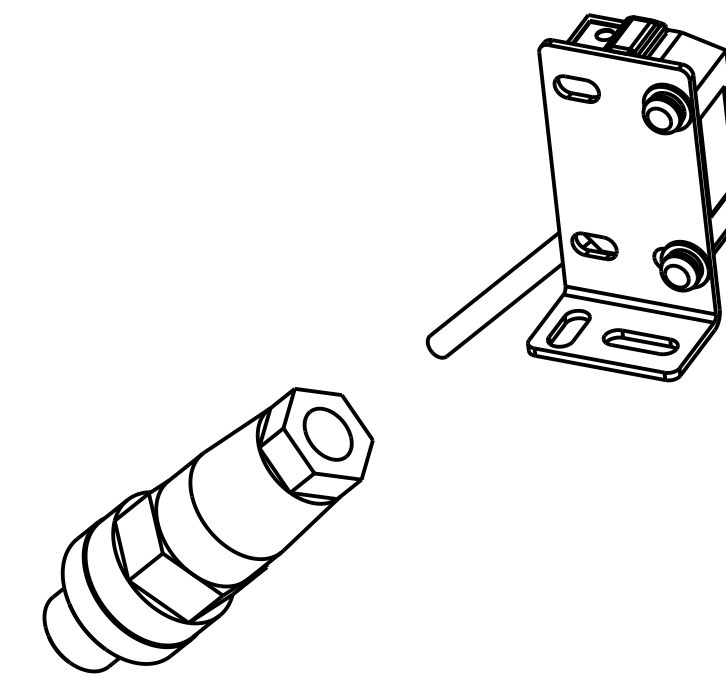
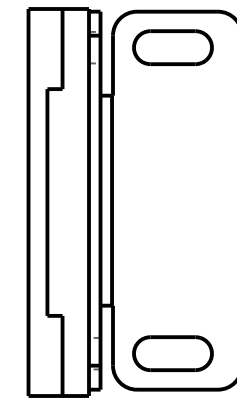
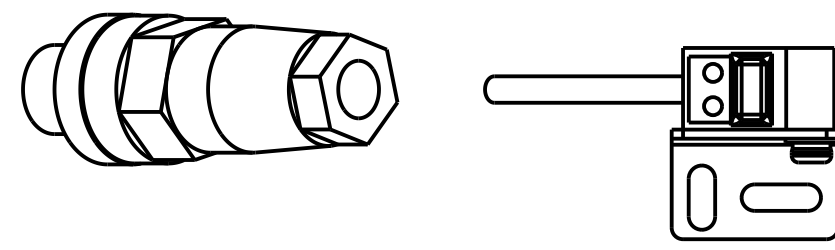

REV	DATE	DESCRIPTION	BY
A	11-16-22	NEW DRAWING	ATT

THIS IS A PRO-ENGINEER DOCUMENT AND MAY NOT BE MODIFIED MANUALLY

UNLESS OTHERWISE SPECIFIED DIMENSIONAL TOLERANCE X ± .1 XX ± .01 .XXX ± .005 ANGLES ± 30°		QUADREL LABELING SYSTEMS 7670 JENTHER DRIVE MENTOR, OHIO 44060 (440) 602-4700	SCALE: 1/1 DATE: 11-16-22 DRAWN BY: ATT
SURFACE FINISH: 125 BREAK ALL EDGES: .0057, .015 CORNER RADIUS: .0107, .030		PRODUCT DETECT, HUGGER MOUNT MAT'L	21679-009 21679-009

PZ-G Series

Instruction Manual

Read this manual thoroughly before using the product.
Keep this manual readily available for future reference.

96M11227



Safety precautions

- Avoid running the PZ-G cable along with power and high voltage lines, as this may cause interference and/or permanent damage.
- When using a commercially available switching regulator, ground its chassis grounding and earth grounding terminals.
- Do not use in locations where direct ambient light or external light directly shines on the light receiving surface.
- With retro-reflective type sensors, when detecting highly reflective materials (such as mirrored surfaces), stabilization may be difficult. To correct this, change the angle of the sensor head, or adjust the sensitivity.
- Avoid using power which exceeds the specifications for ripple (10% max)
- Avoid using excess force when rotating the operation mode selector switch (Light-on, Dark-on) and the sensitivity adjustment trimmer.
- This product is just intended to detect the object(s). Do not use this product for the purpose to protect a human body or a part of human body.
- This product is not intended for use as explosion-proof product. Do not use this product in a hazardous location and/or potentially explosive atmosphere.

Precautions on Regulations and Standards

UL Certificate

This product is an UL/C-UL Listed product.

- UL File No. E301717
- Category NRKH,NRKH7
- Enclosure Type 1 (Based on UL50)

Be sure to consider the following specifications when using this product as an UL/C-UL Listed Product.

- Use the power supply with Class 2 output defined in NFPA70 (NEC: National Electrical Code).
- Power supply/ Control input/ Control output circuits shall be connected to a single Class 2 source only.
- Use with the over current protection device which is rated 30V or more and not more than 1A.

Part Names

PZ-G5xN/G5xP

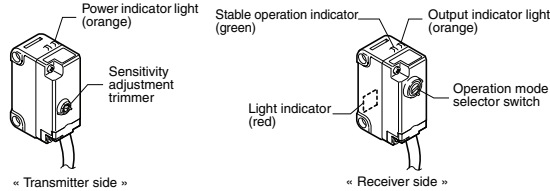

PZ-G5xB

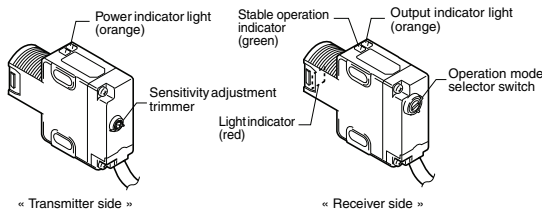

PZ-G4xN/G4xP/G10xN/G10xP/G6xN/G6xP

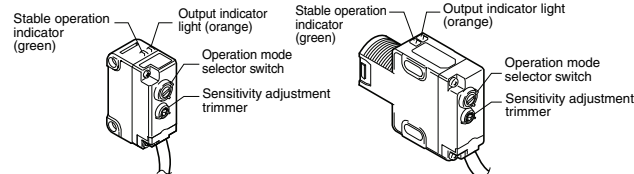

* The model name with "C" (PZ-GxxCx) is the connector type, and the model name with "E" (PZ-GxxEx) is the pigtail quick disconnect type.

Mounting Method

Side Mounting (Prepare M3 screws)

Tightening torque: 0.5 N·m or less

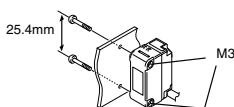

Tightening torque: 0.5 N·m or less

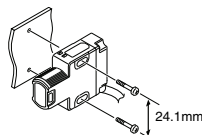

Mounting with the M18 nut (includes nut type)

The M18 nut is also available separately as OP-84225 (2 pcs. supplied).
Tightening torque: 1.0 N·m or less

Panel (5 mm or less)

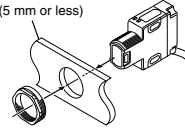

Panel cut size

$\phi 18.5 \pm 0.2$ mm

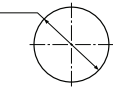

Note

- Mount the M18 nut (supplied) straight in. If mounted at an angle it cannot be tightened properly.
- When tightening the M18 nut (supplied), firmly hold the main body down. The case of the main body may be damaged if held in place with a tool such as pliers.
- When tightening the M18 nut (supplied), if excess force is applied to the nut with a tool such as pliers, it may bend it out of shape. Therefore, do not apply excess force.

Sensitivity Adjustment Method

Caution



Avoid using excess force when rotating the sensitivity adjustment trimmer and operation mode selector switch as it may cause damage.

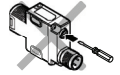

Operation mode selector switch

With the operation mode selector switch, you can select either the LIGHT-ON mode (L) or the DARK-ON (D) mode.



Reflective type (PZ-G41/G42/G101/G102/G10R/G10G/G10B Series)

The following assumes LIGHT-ON (L) is set.

Sequence	Adjustment method	Sensitivity adjustment trimmer
①	Position target in place. Slowly rotate the sensitivity trimmer from the MIN position towards the MAX position until the (orange) output indicator turns on (Position "A"). If the output indicator does not turn off, even at MIN, then MIN is considered Position "A".	
②	Remove the target. Adjust the sensitivity trimmer from MIN towards MAX until the (orange) output indicator turns on (Position "B"). If the output indicator does not light up, the MAX position is considered Position "B".	
③	Adjust the sensitivity trimmer to the midpoint between "A" and "B". Verify that the (green) stable operation light turns on with and without a target in place.	

Reference To use the sensor in DARK-ON mode, adjust the mode selector switch to "D".

Thrubeam type (PZ-G51/G52 Series) / Retro-reflective type (PZ-G61/G62 Series)

The following assumes DARK-ON (D) is set.

Sequence	Adjustment method	Sensitivity adjustment trimmer
①	Remove the target. Adjust the sensitivity trimmer to MAX. Mount the sensor heads in place so the (orange) output indicator turns off (on thrubeam models, the red light on the receiver face will turn on)	
②	Position target in place. Verify that the orange output indicator turns on (on thrubeam models, the red light on the receiver face will turn off). Adjust sensitivity lower if the output indicator does not turn on (or if the red light on the receiver face does not turn off on thrubeam models)	

Reference To use the sensor in LIGHT-ON mode, adjust the mode selector switch to "L".

I/O Circuit Diagram

PZ-G5xN/G5xP/G5xB (Transmitter side)

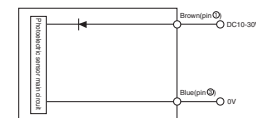

PZ-G5xN (Receiver side)/ G4xN/G10xN/G6xN

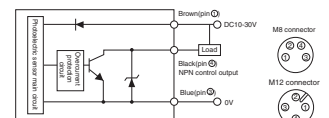

PZ-G5xP (Receiver side)/ G4xP/G10xP/G6xP

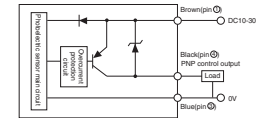

PZ-G5xB (Receiver side)/ G4xB/G10xB/G6xB

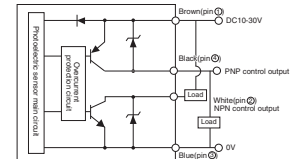

* The pin numbers represent those of the connector type / pigtail quick disconnect type. The model name with "C" (PZ-GxxCx) is the connector type, and the model name with "E" (PZ-GxxEx) is the pigtail quick disconnect type.

[PZ-GxxCN/GxxCP..... M8 connector
PZ-GxxCB/GxxEN/GxxEP..... M12 connector]

Indicators

The following describes each ON/OFF condition of indicator when LIGHT-ON (L) is set.

Reference When the DARK-ON (D) is set, the output indicator ON/OFF will reverse.

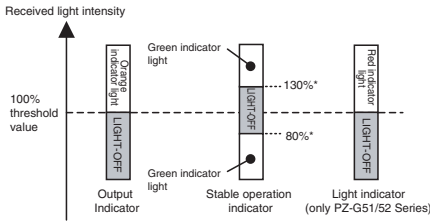

* For PZ-G62, the upper limit is 107% and the lower limit is 93%.

If the stable operation indicator turns off during operation, readjust or fine-adjust the sensitivity.

Mutual interference

- For reflective type / retro-reflective type sensors, mutual interference protection can be set for up to 2 units. However, when the sensors are mounted facing each other, change the angle of the sensor head to prevent light being emitted into each unit. (The mark detection type does not include the mutual interference function.)
- Mutual interference prevention can be set when mounting a polarizing filter attachment (optional with thru-beam type sensors) (If operation is unstable even after mounting the polarizing filter, slightly lower the sensitivity.)
- For more detailed information about mutual interference or attachment, see the PZ-G Series catalog or contact your nearest KEYENCE office.

Specifications

Type		Thru-beam		Reflective				Retro-reflective		Mark detection			
Configuration	Cable shape	Output mode	Normal	High-power	Diffuse-reflective Long-detecting distance	Diffuse-reflective Short-detecting distance	Narrow-view reflective	Definite reflective	Long detecting distance (with P.R.O. function)	Transparent target detection (without P.R.O. function)	Red	Green	Blue
Rectangular	Cable	NPN	PZ-G51N	PZ-G52N	PZ-G41N	PZ-G42N	PZ-G101N	PZ-G102N	PZ-G61N	PZ-G62N			
		PNP	PZ-G51P	PZ-G52P	PZ-G41P	PZ-G42P	PZ-G101P	PZ-G102P	PZ-G61P	PZ-G62P			
	M8 connector	NPN	PZ-G51CN	PZ-G52CN	PZ-G41CN	PZ-G42CN	PZ-G101CN	PZ-G102CN	PZ-G61CN	PZ-G62CN	PZ-G10RCN	PZ-G10GCN	PZ-G10BCN
		PNP	PZ-G51CP	PZ-G52CP	PZ-G41CP	PZ-G42CP	PZ-G101CP	PZ-G102CP	PZ-G61CP	PZ-G62CP	PZ-G10RCP	PZ-G10GCP	PZ-G10BCP
Nut	Cable	NPN	PZ-G51EN	PZ-G52EN	PZ-G41EN	PZ-G42EN	PZ-G101EN	PZ-G102EN	PZ-G61EN	PZ-G62EN			
		PNP	PZ-G51EP	PZ-G52EP	PZ-G41EP	PZ-G42EP	PZ-G101EP	PZ-G102EP	PZ-G61EP	PZ-G62EP			
Nut	M12 connector	Bipolar	PZ-G51B	PZ-G52B	PZ-G41B	PZ-G42B	PZ-G101B	PZ-G102B	PZ-G61B	PZ-G62B			
		(NPN+PNP)	PZ-G51CB	PZ-G52CB	PZ-G41CB	PZ-G42CB	PZ-G101CB	PZ-G102CB	PZ-G61CB	PZ-G62CB			
Detecting distance ^{*1}			20 m	40 m	1 m (30 x 30 cm white mat paper)	300 mm (10 x 10 cm white mat paper)	200 mm	5 to 45 mm	0.1 to 4.2 m (when R-2L reflector is used)	0.1 to 1 m (when R-2L reflector is used)	8 to 15 mm		
Spot diameter			-	-	-	-	Approx. φ 5 mm (when the detecting distance is 100 mm)	Approx. φ 2 mm (when the detecting distance is 40 mm)	-	-	Approx. 1.5 x 4 mm (when the detecting distance is 10 mm)		
Light source (LED)			Red LED	Infrared LED x 2	Red LED				Infrared LED		Red LED	Green LED	Blue LED
Sensitivity adjustment		1-turn trimmer (230 degrees)											
Response time		500 μs										50 μs	
Operation mode		LIGHT-ON/DARK-ON, trimmer-selectable											
Indicator (LED)		Transmitter: power (orange) Receiver: output (orange), stable operation (green), light (red)			Output (orange), stable operation (green)								
Control output		Open-collector 100 mA max. (30 V max.), Residual voltage 1 V max.											
Protection circuit		Reverse-polarity protection, over-current protection, output surge absorber											
Ratings		Power voltage		10 to 30 VDC, Ripple (P-P): ±10% max, Class 2.									
		Current consumption		Transmitter: 20 mA max. Receiver: 28 mA max.		Transmitter: 25 mA max. Receiver: 28 mA max.		34 mA max.					
Environmental resistance		Enclosure rating		IEC/JEM: IP67 / NEMA: 4X,6,12 / DIN: IP69K									
		Ambient light		Incandescent lamp: 5,000 (lx) max, Sunlight: 20,000 (lx) max.									
		Ambient temperature		-20 °C to +55 °C (No freezing)									
		Relative humidity		35 to 85 % RH (No condensation)									
		Vibration resistance		10 to 55 Hz, 1.5 mm double amplitude in X, Y, Z directions, 2 hours each									
		Shock resistance		1000 m/s ² in X, Y, Z directions, 6 times each									
Interference prevention		2 units (when polarizing filter attachment is used)		2 units (with the automatic different cycle function)									
Material		Case, M18 nut (nut type only): reinforced glass polybutylene terephthalate (PBT), Trimmer: reinforced glass polyamide (PA) Cable (Cable type / pigtail quick disconnect type only): Polyvinyl chloride (PVC), Screw (Case connection): Steel, zinc-nickel plated, Packing (Case connection): Nitrile-butadiene rubber (NBR) Connector (pigtail quick disconnect type only): Brass-nickel plated, Polybutylene terephthalate (PBT), Polyvinyl chloride (PVC)											
		Lens cover		Polyarylate (PAR)				Acrylic plastic (PMMA)		Polyarylate (PAR)			
Tightening torque		Rectangular type (side screw part): 0.5 N·m max. Nut type (front M18 part): 1.0 N·m max., (side slot part): 0.5 N·m max.											
Accessory ^z		Instruction manual, M18 nut x 2 (nut thru-beam type), M18 nut x 1 (other nut types)											
Weight		Rectangular cable type: Approx. 60 g (Approx. 50 g for thru-beam transmitter), Rectangular M8 connector type: Approx. 10 g, rectangular M12 pigtail quick disconnect type: Approx. 30 g Nut type cable type: Approx. 65 g (Approx. 55 g for thru-beam transmitter), Nut type M12 connector type: Approx. 15 g											

*1 The detection distance is measured with the maximum sensitivity.

*2 The cable for the connector type / pigtail quick disconnect type is sold separately. The reflector for the retro-reflective type is sold separately.

WARRANTY

KEYENCE products are strictly factory-inspected. However, in the event of a failure, contact your nearest KEYENCE office with details of the failure.

1. WARRANTY PERIOD

The warranty period shall be for one year from the date that the product has been delivered to the location specified by the purchaser.

2. WARRANTY SCOPE

(1) If a failure attributable to KEYENCE occurs within the abovementioned warranty period, we will repair the product, free of charge. However, the following cases shall be excluded from the warranty scope.

- Any failure resulting from improper conditions, improper environments, improper handling, or improper usage other than described in the instruction manual, the user's manual, or the specifications specifically arranged between the purchaser and KEYENCE.
- Any failure resulting from factors other than a defect of our product, such as the purchaser's equipment or the design of the purchaser's software.
- Any failure resulting from modifications or repairs carried out by any person other than KEYENCE staff.
- Any failure that can certainly be prevented when the expendable part(s) is maintained or replaced correctly as described in the instruction manual, the user's manual, etc.
- Any failure caused by a factor that cannot be foreseen at a scientific/technical level at the time when the product has been shipped from KEYENCE.
- Any disaster such as fire, earthquake, and flood, or any other external factor, such as abnormal voltage, for which we are not liable.

(2) The warranty scope is limited to the extent set forth in item (1), and KEYENCE assumes no liability for any purchaser's secondary damage (damage of equipment, loss of opportunities, loss of profits, etc.) or any other damage resulting from a failure of our product.

3. PRODUCT APPLICABILITY

KEYENCE products are designed and manufactured as general-purpose products for general industries.

Therefore, our products are not intended for the applications below and are not applicable to them. If, however, the purchaser consults with us in advance regarding the employment of our product, understands the specifications, ratings, and performance of the product on their own responsibility, and takes necessary safety measures, the product may be applied. In this case, the warranty scope shall be the same as above.

- Facilities where the product may greatly affect human life or property, such as nuclear power plants, aviation, railroads, ships, motor vehicles, or medical equipment
- Public utilities such as electricity, gas, or water services
- Usage outdoors, under similar conditions or in similar environments

E 1040-1

KEYENCE CORPORATION

1-3-14, Higashi-Nakajima, Higashi-Yodogawa-ku,
Osaka, 533-8555, Japan

PHONE: +81-6-6379-2211 www.keyence.com

Specifications are subject to change without notice.

A7WW1-MAN-0069

Copyright (c) 2010 KEYENCE CORPORATION. All rights reserved.

11227E 1070-1 96M11227J

Printed in Japan



ASSEMBLY TITLE: HEAD SUPPORT ASSEMBLY

GENERAL FUNCTION:

The head support assembly keeps the labeling head in a “locked position” and prevents head vibration and wobbling as the label motor is engaged. The head support assembly is also used to set the camber or front/back tilt of the head.

SETUP AND ADJUSTMENTS:

HORIZONTAL ADJUSTMENT: To set the horizontal position of the labeling head, use the side mount wheel handle (some older systems may feature the ratcheted handle). Turn the handle clockwise to move the head towards the conveyor. Turn it counter clockwise to move the head away from the conveyor.

VERTICAL ADJUSTMENT: Using the lower wheel handle to set the vertical position of the labeling head. Turn the wheel clockwise to lower labeling head. Turn the wheel counter clockwise to raise the labeling head.

MAINTENANCE:

No scheduled maintenance is required for this assembly. Always keep the drive areas free of label flash and debris.

TROUBLESHOOTING: None this section.

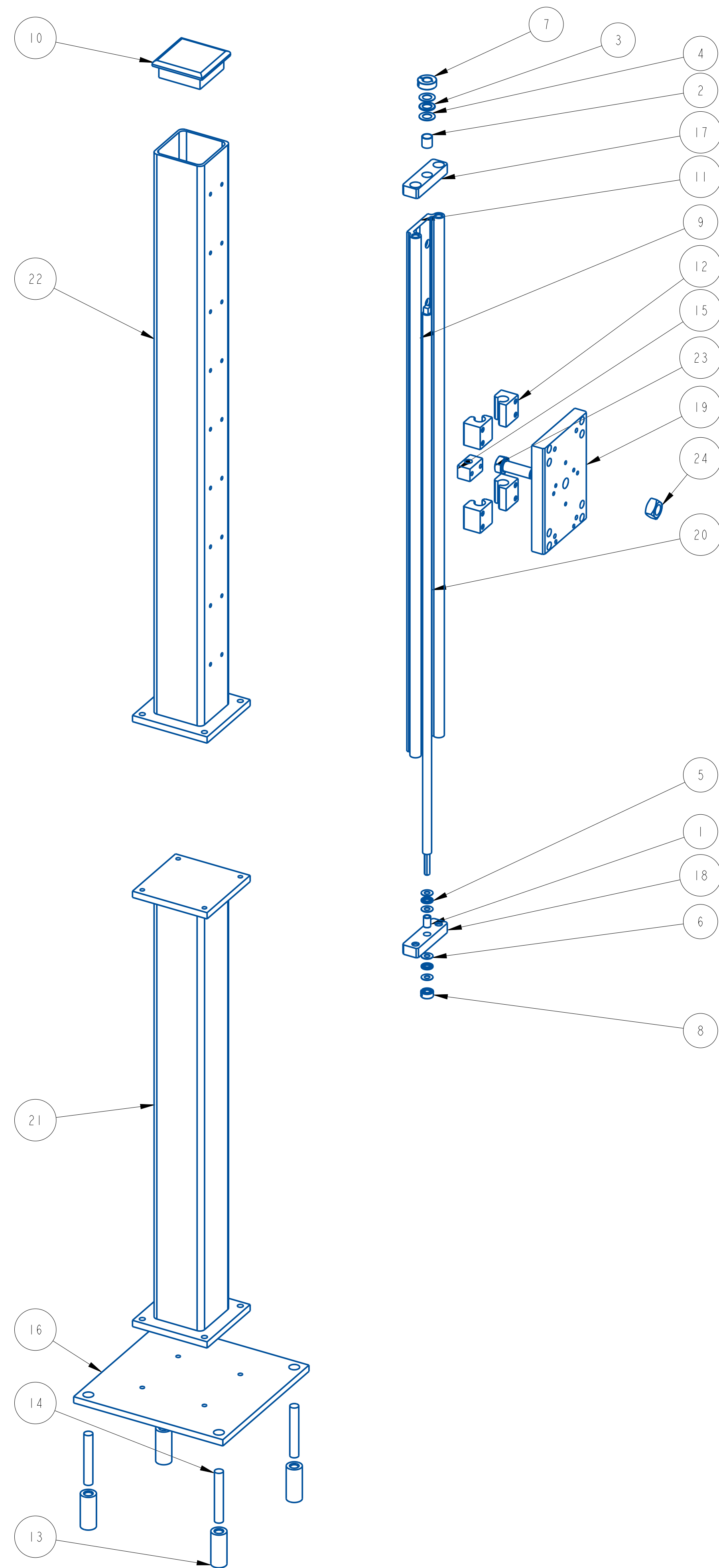

ITEM	QTY	PART NO.	DESCRIPTION	PARENT ITEM
1	1	141172-000	SLEEVE BEARING, 1/20D. x 3/8ID. x 3/4LNG	21654-008
2	1	141173-000	SLEEVE BEARING	21654-008
3	1	181081-000	BEARING, NEEDLE ROLLER	21654-008
4	2	181082-000	BEARING, THRUST WASHER	21654-008
5	2	181108-000	BEARING, NEEDLE ROLLER	21654-008
6	4	181111-000	THRUST WASHER	21654-008
7	1	361182-000	COLLAR, 5/8 IN. ID ONE-PIECE CLAMP	21654-008
8	1	362186-000	COLLAR, 3/8 IN. ID ONE-PIECE CLAMP	21654-008
9	1	791914-001	MYLAR SCALE, QUADREL LOGO	21654-008
10	1	792065-000	CAP INSERT FOR 4X4 TUBE (1/4WALL)	21654-008
11	1	792247-000	DRYLIN RAIL	21654-008
12	4	792248-001	PILLOW BLOCK	21654-008
13	4	841796-000	ANCHOR	21654-008
14	4	841797-000	STUD	21654-008
15	1	A24077-000	BRONZE NUT, RH	21654-008
16	1	A25723-011		21654-008
17	1	B21345-000	TOP BEARING PLATE	21654-008
18	1	B21346-000	BOTTOM BEARING PLATE	21654-008
19	1	C20626-000	STAND SLED	21654-008
20	1	C20835-000	THREADED ROD, SQUARE END	21654-008
21	1	D21045-013		21654-008
22	1	D21045-014		21654-008
23	1	HCS281		21654-008
24	1	SNQ022		21654-008

A		Jan-09-26	NEW DRAWING	TAZ
REV	DATE	DESCRIPTION	BY	

THIS IS A PRO-ENGINEER DOCUMENT AND MAY NOT BE MODIFIED MANUALLY

UNLESS OTHERWISE SPECIFIED
DIMENSIONAL TOLERANCE
 X ± .1
 XX ± .01
 XXX ± .005
 ANGLES ± 30'

SURFACE FINISH 125
 BREAK ALL EDGES .005/.015
 CORNER RADIUS .010/.030
 ALL ANGLES ARE 90°

QUADREL LABELING SYSTEMS
 7670 JENTHER DRIVE
 MENTOR, OHIO 44060
 (440) 602-4700

SCALE: 3/16
 DATE: Jan-09-26
 DRW BY: TAZ
 CHK BY:
 APPR BY:

80" 2 PIECE STAND

MAT'L	21654-008	21654-008
-------	-----------	-----------

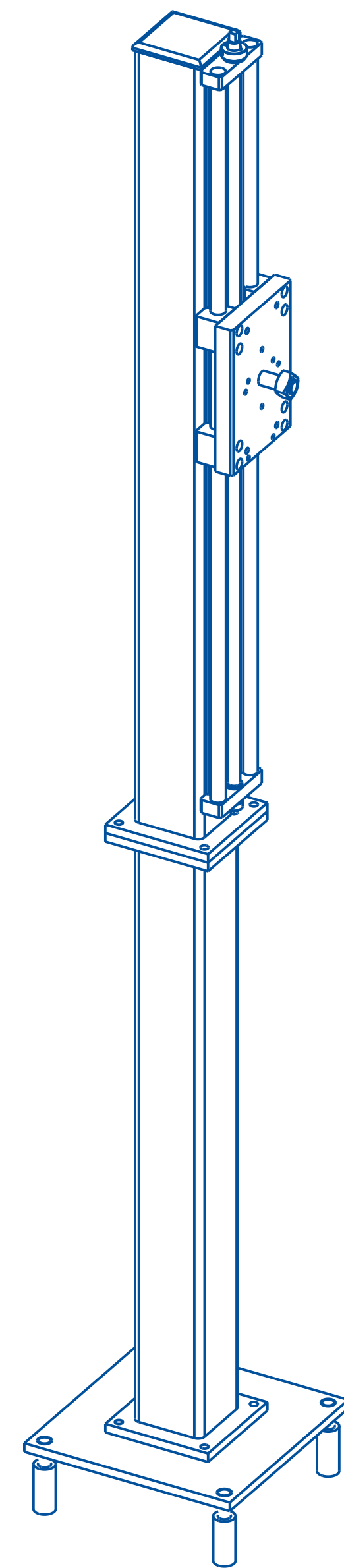
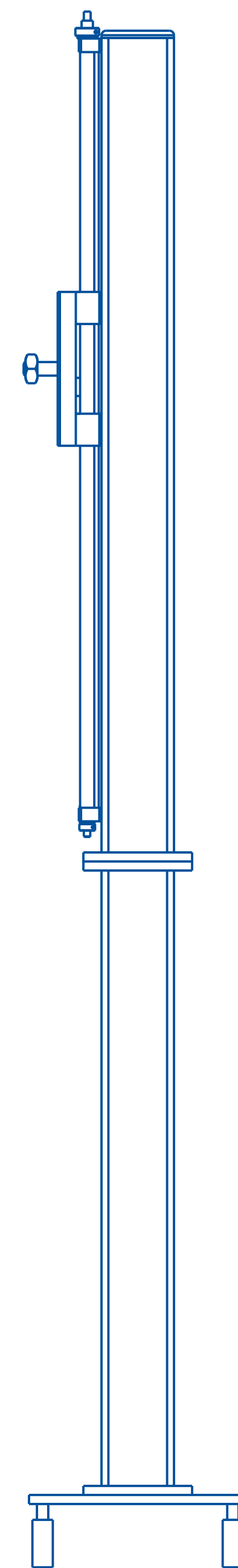
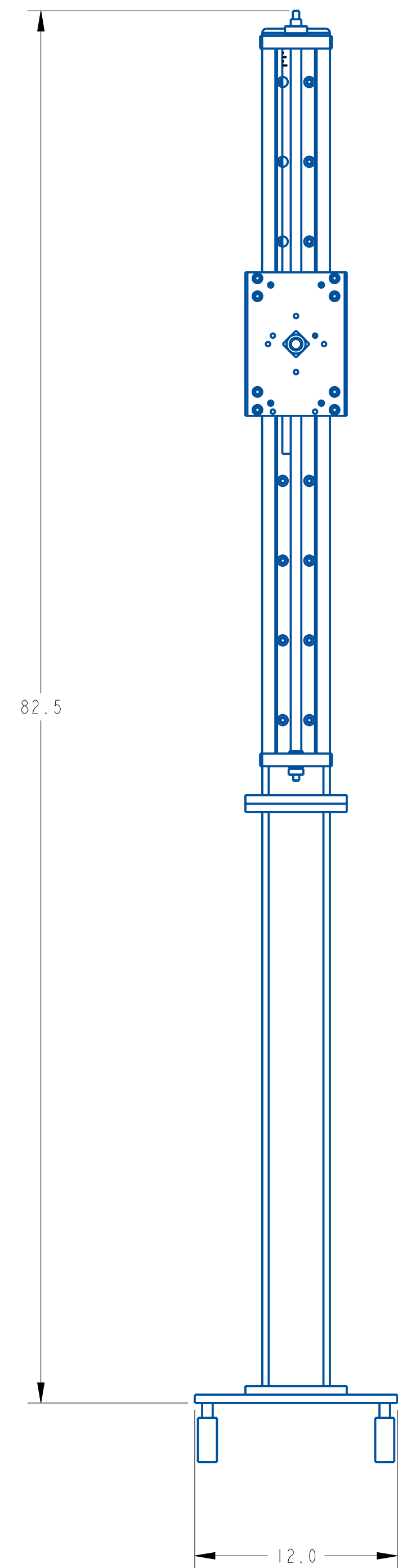
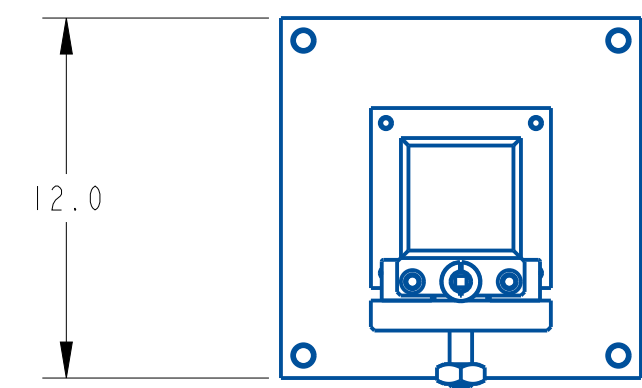

UNLESS OTHERWISE SPECIFIED		SCALE: 5/32	
DIMENSIONAL TOLERANCE		DATE: Jan-09-26	
x ± .1		DRW BY: TAZ	
xx ± .01		CHK BY:	
xxx ± .005		APPR BY:	
ANGLES ± .30°		80" 2 PIECE STAND	
SURFACE FINISH 125		MATERIAL 21654-008	
BREAK ALL EDGES .005/ .015		21654-008	
CORNER RADIUS .010/ .030		21654-008	
ALL ANGLES ARE 90°			

A	Jan-09-26	NEW DRAWING	TAZ
REV	DATE	DESCRIPTION	BY

THIS IS A PRO-ENGINEER DOCUMENT AND MAY NOT BE MODIFIED MANUALLY

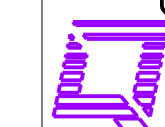

QUADREL LABELING SYSTEMS
 7670 JENTHER DRIVE
 MENTOR, OHIO 44060
 (440) 602-4700

ITEM	QTY	PART NO.	DESCRIPTION	PARENT ITEM
1	2	111072-000	BEARING, BALL	22489-001
2	1	141172-000	SLEEVE BEARING, 1/2OD. x 3/8ID. x 3/4LNG	22489-001
3	2	151018-000	BEARING, THRUST WASHER	22489-001
4	1	191562_000	BELT, TIMING 1/5P	22489-001
5	1	361169-000	COLLAR, 1/2 IN. ID ONE-PIECE CLAMP	22489-001
6	1	801079-000	4" DIA HANDWHEEL 1/2" BORE	22489-001
7	1	A25701-000	HANDLE SHAFT	22489-001
8	1	A25702-000	TIMING PULLEY	22489-001
9	1	A25881-000	TIMING PULLEY	22489-001
10	1	B22738-000	BOTTOM BEARING PLATE	22489-001

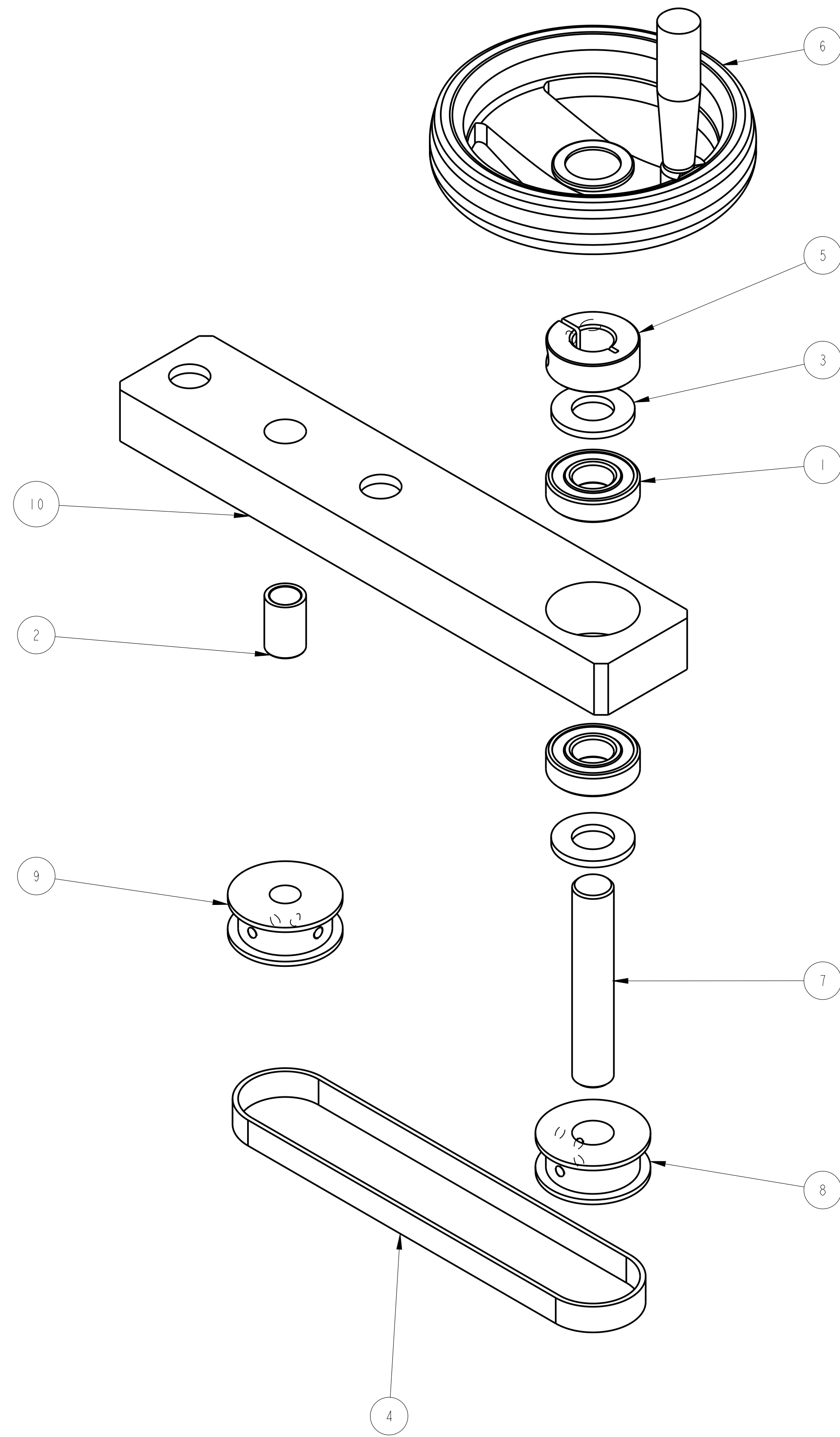

REV	DATE	DESCRIPTION	BY
A	02/24/2012	NEW DRAWING	SEM

THIS IS A PRO-ENGINEER DOCUMENT AND MAY NOT BE MODIFIED MANUALLY

UNLESS OTHERWISE SPECIFIED
DIMENSIONAL TOLERANCE
X ± .1
XX ± .01
XXX ± .005
ANGLES ± 30°

SURFACE FINISH 125
BREAK ALL EDGES .005/.015
CORNER RADIUS .010/.030

QUADREL LABELING SYSTEMS
7670 JENTHER DRIVE
MENTOR, OHIO 44060
(440) 602-4700

SCALE: 1/1
DATE: 02/24/2012
DRW BY: SEM
CHK BY: 07/20/2024-SEM
APPR BY:

4" HANDWHEEL EXTENSION KIT

MAT'L BOM: 22489-001

D24223-000

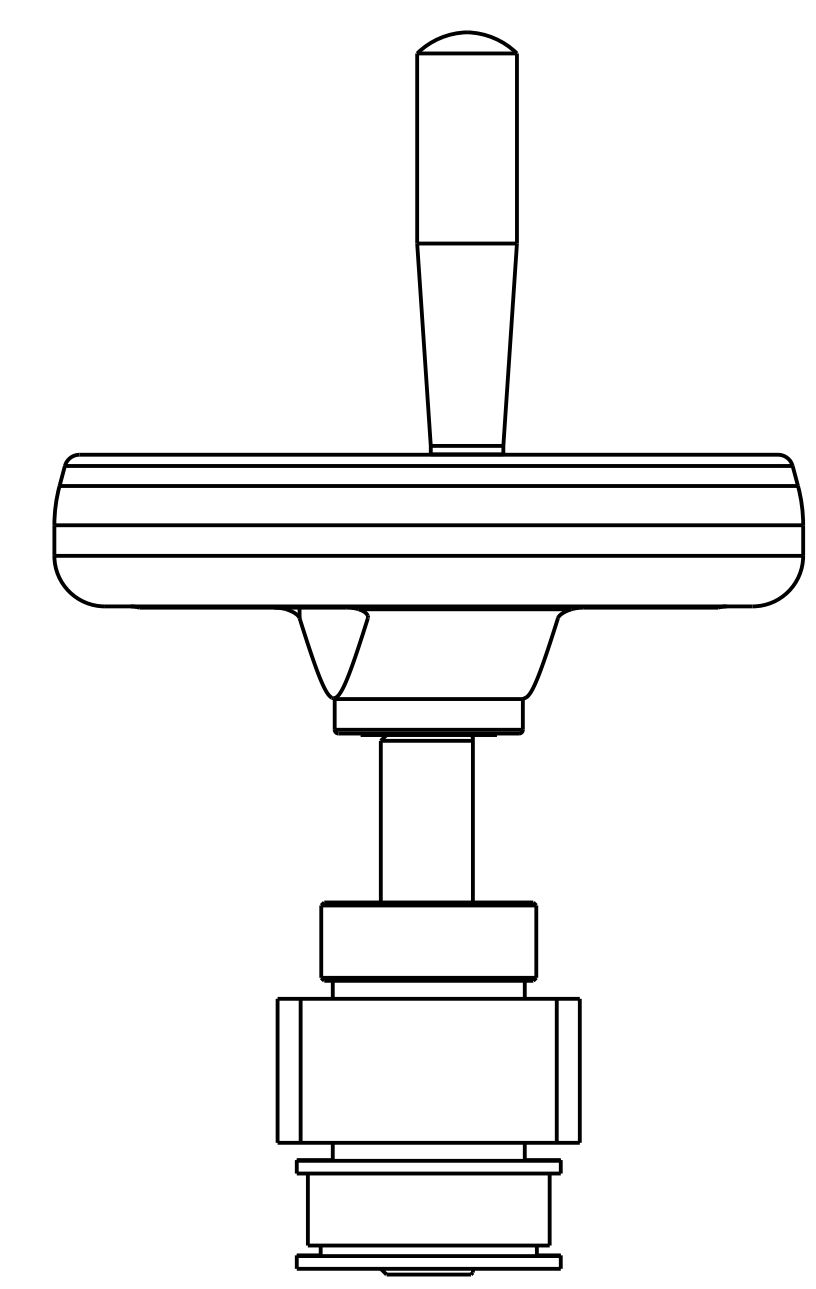
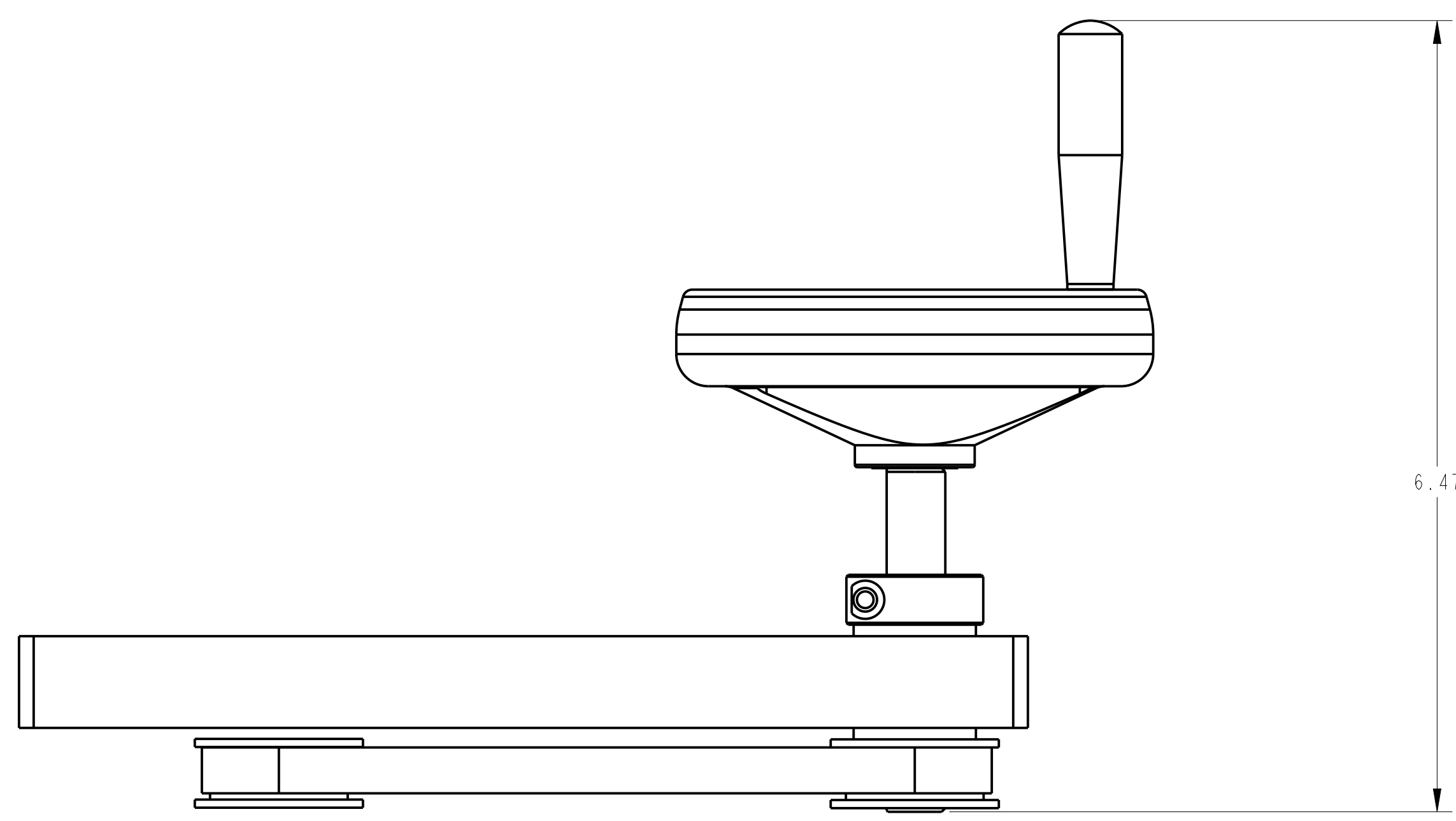
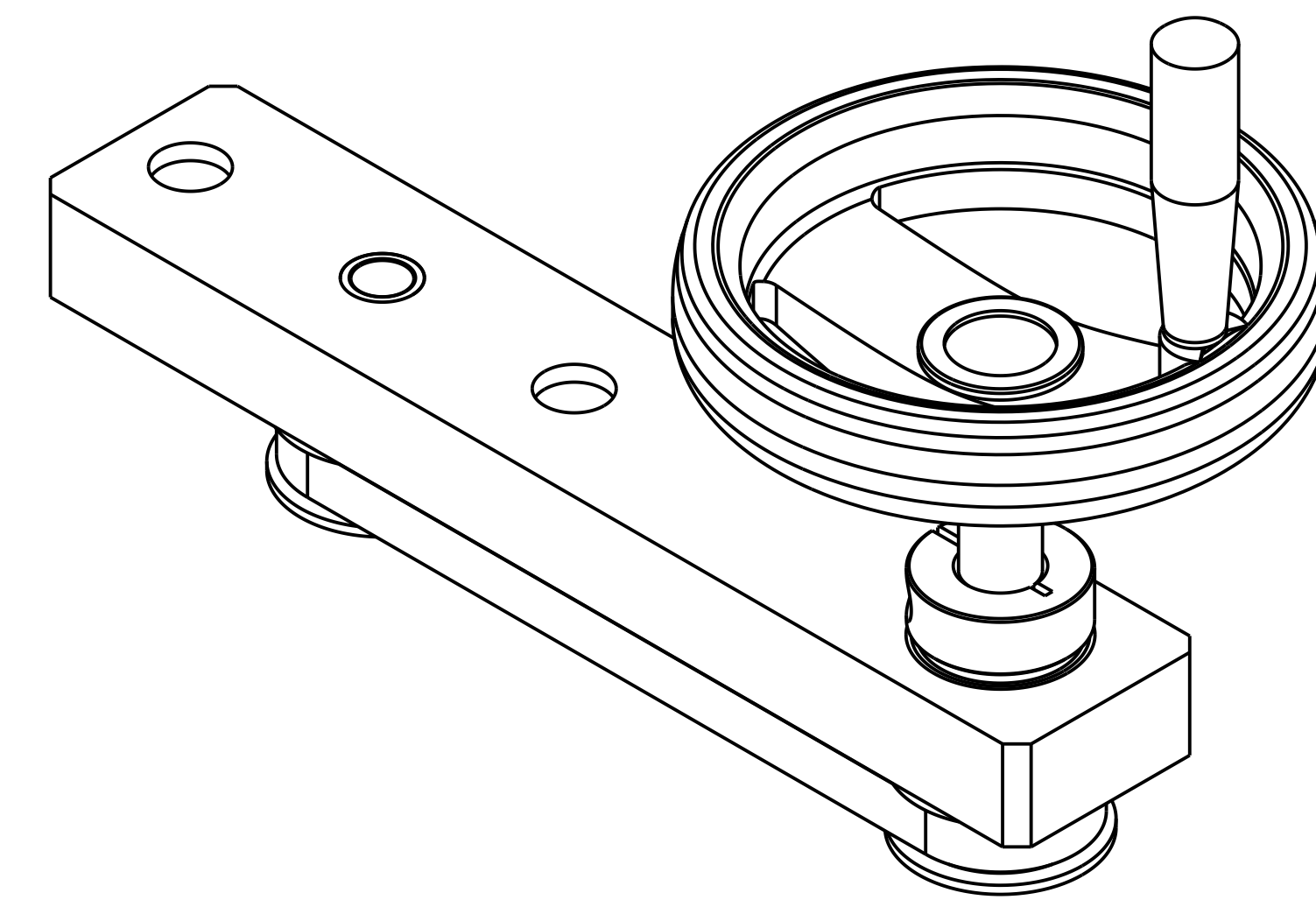
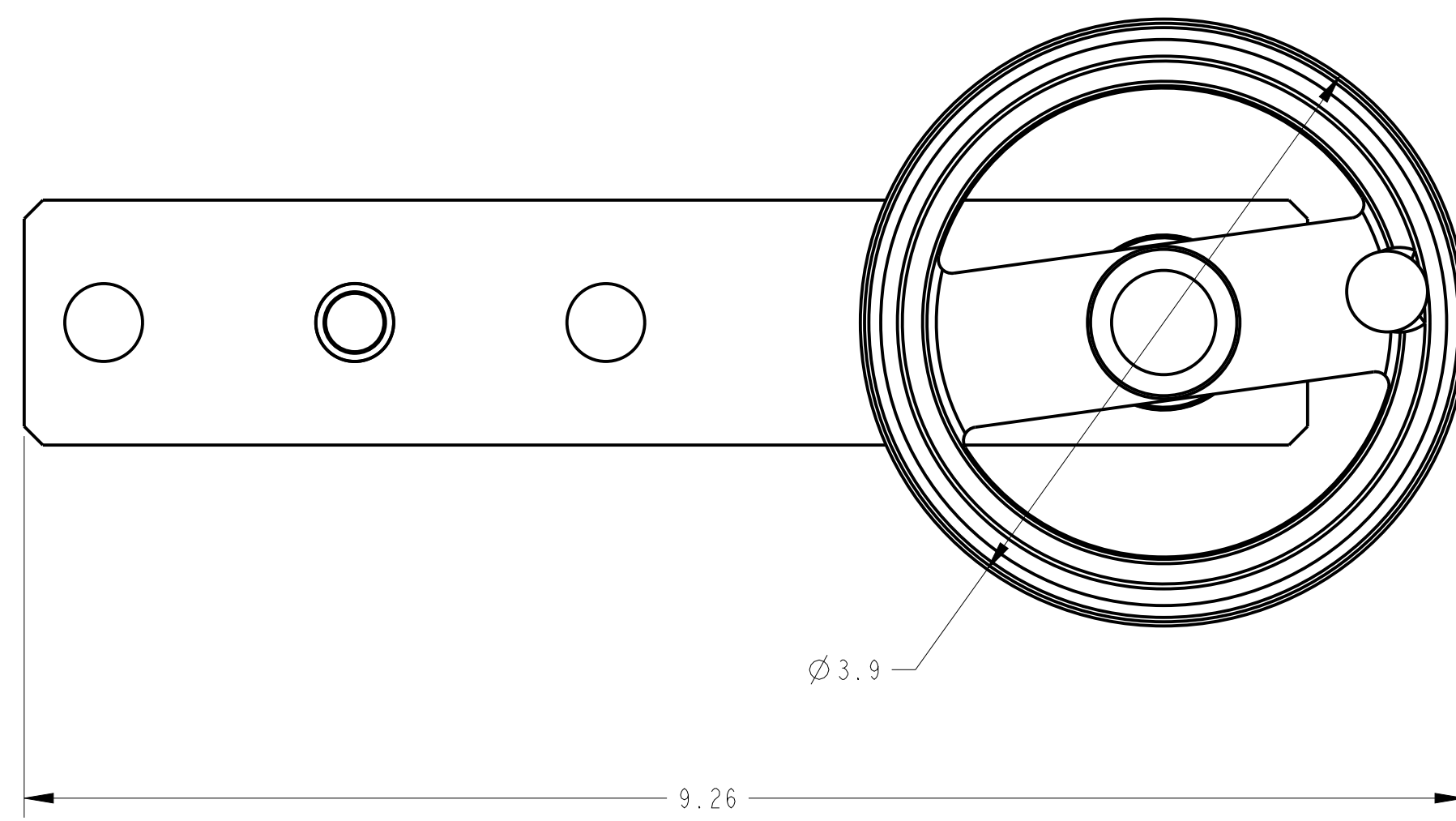

REV	DATE	DESCRIPTION	BY
A	02/24/2012	NEW DRAWING	SEM

THIS IS A PRO-ENGINEER DOCUMENT AND MAY NOT BE MODIFIED MANUALLY

UNLESS OTHERWISE SPECIFIED DIMENSIONAL TOLERANCE	QUADREL LABELING SYSTEMS 7670 JENTHER DRIVE MENTOR, OHIO 44060 (440) 602-4700	SCALE: 1/1 DATE: 02/24/2012 DRW BY: SEM CHK BY: 07/20/2024-SEM APPR BY:
x ± .1 xx ± .01 xxx ± .005 ANGLES ± .30°	4" HANDWHEEL EXTENSION KIT	
SURFACE FINISH 125 BREAK ALL EDGES .005/ .015 CORNER RADIUS .010/ .030 ALL ANGLES ARE 90°	MAT'L BOM: 22489-001	D24223-000

ITEM	QTY	PART NO.	DESCRIPTION	PARENT ITEM
1	1	141177-000	SLEEVE BEARING, 5/8OD. x 1/2ID. x 3/4LNG	84127H-000
2	2	181079-000	BEARING, NEEDLE ROLLER	84127H-000
3	4	181080-000	BEARING, THRUST WASHER	84127H-000
4	1	361169-000	COLLAR, 1/2 IN. ID ONE-PIECE CLAMP	84127H-000
5	4	792248-001	PILLOW BLOCK	84127H-000
6	1	792354-000	DIGITAL POSITION INDICATOR	84127H-000
7	1	792355-000	DRYLIN RAIL	84127H-000
8	2	793045-000	DIAMOND KNURL KNOB	84127H-000
9	1	801080-000	6" HANDWHEEL	84127H-000
10	1	A24077-000	BRONZE NUT, RH	84127H-000
11	2	A26179-83702	KNOB STUD	84127H-000
12	2	B20823-004	YARD ARM GUSSET	84127H-000
13	1	B20827-000	YARD ARM MOUNTING PLATE	84127H-000
14	1	B22005-012	BEARING PLATE	84127H-000
15	1	C20626-015	STAND SLED	84127H-000
16	1	C20977-030	THREADED ROD, RH	84127H-000
17	1	C21189-001	TOP PLATE YARD ARM	84127H-000
18	1	C21348-000	ADJUSTMENT PLATE	84127H-000
19	1	HCS281		84127H-000
20	1	SN022		84127H-000

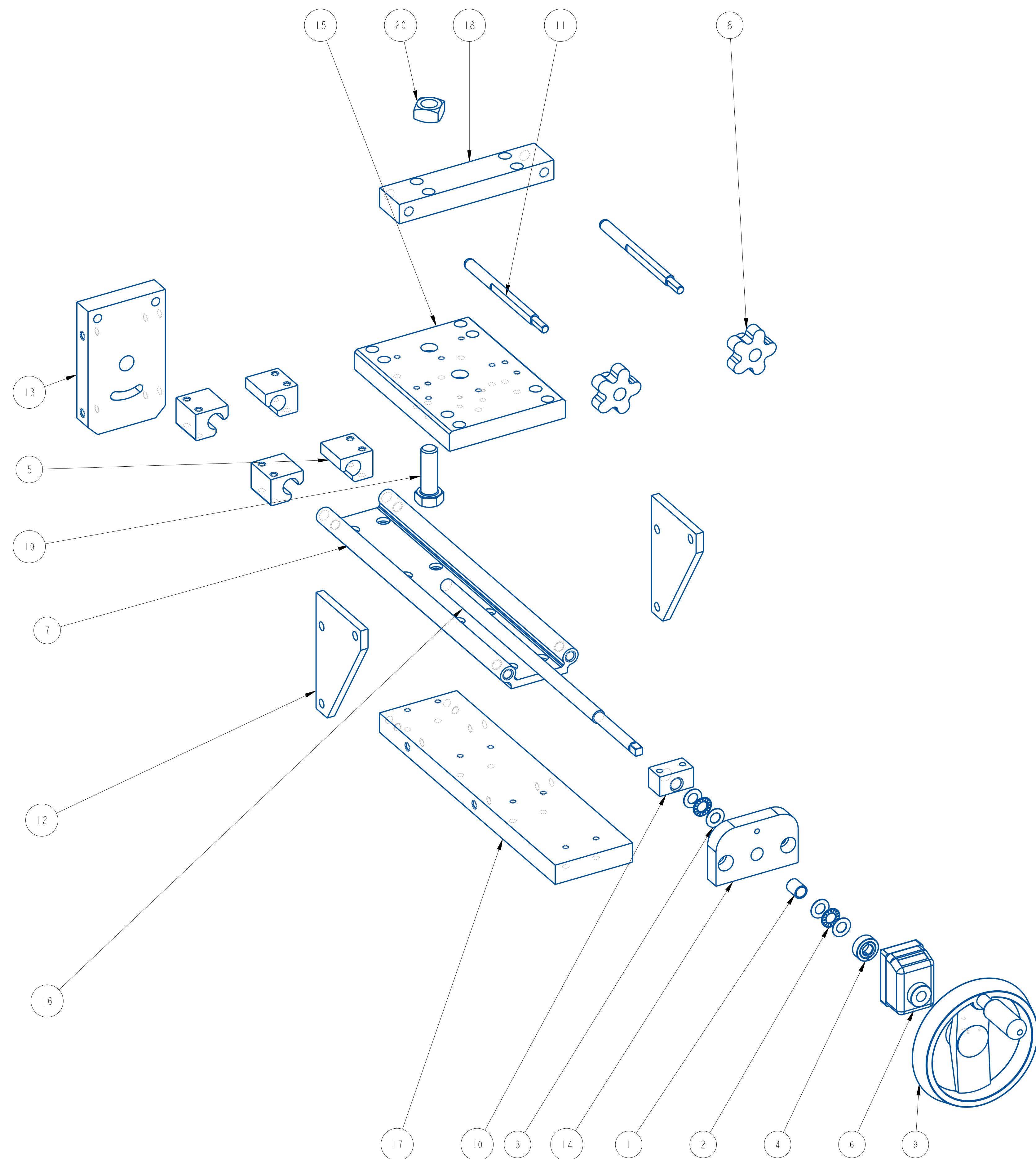

A		Mar-10-25	NEW DRAWING	TAZ
REV	DATE	DESCRIPTION	BY	

THIS IS A PRO-ENGINEER DOCUMENT AND MAY NOT BE MODIFIED MANUALLY

<small>UNLESS OTHERWISE SPECIFIED DIMENSIONAL TOLERANCE X ± .01 XX ± .01 XXX ± .005 ANGLES ± .30°</small>	QUADREL LABELING SYSTEMS		SCALE: 3/8
	7670 JENTHER DRIVE		DATE: Mar-10-25
	MENTOR, OHIO 44060		DRW BY: TAZ
	(440) 602-4700		CHK BY: 03/15/2025-SEM
YARDARM w/HORIZONTAL ADJUST			APPR BY:

MAT'L 84127H-000

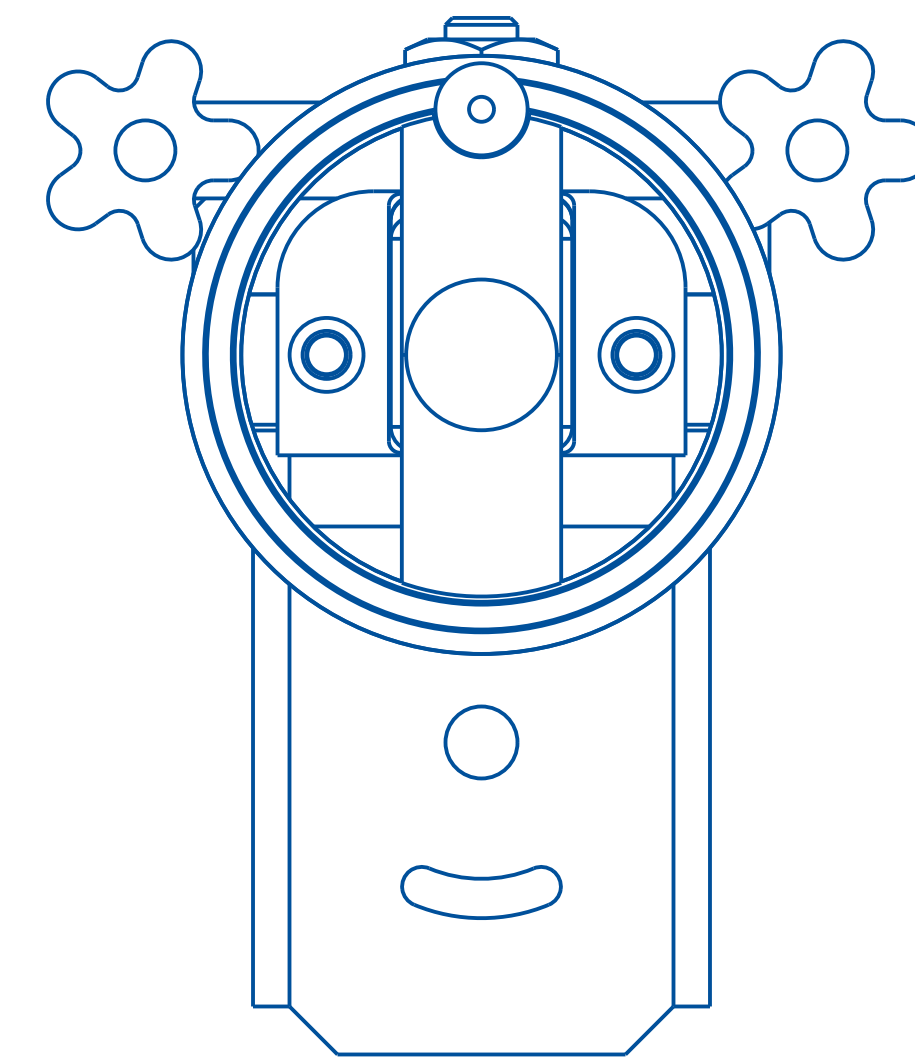
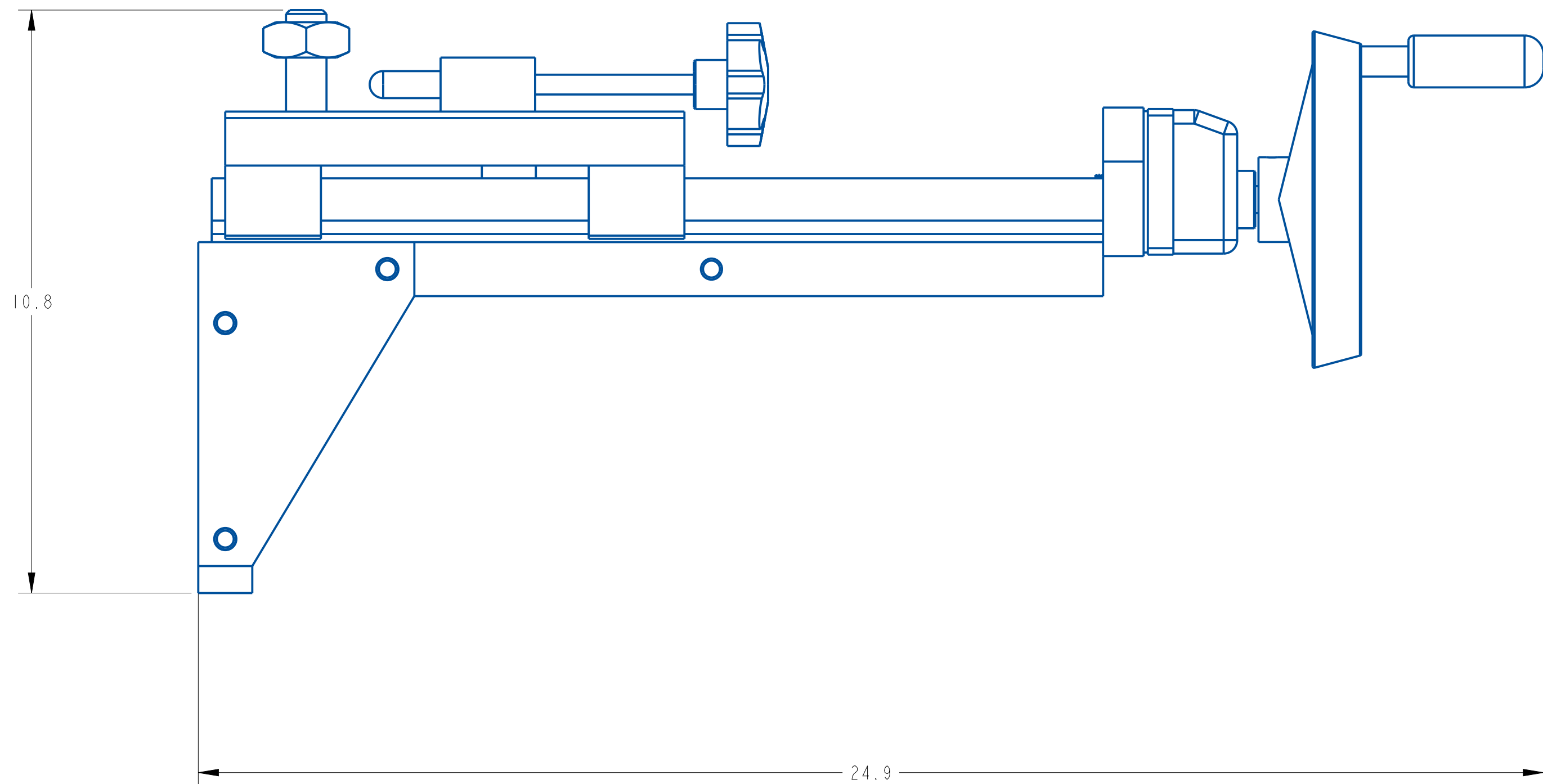
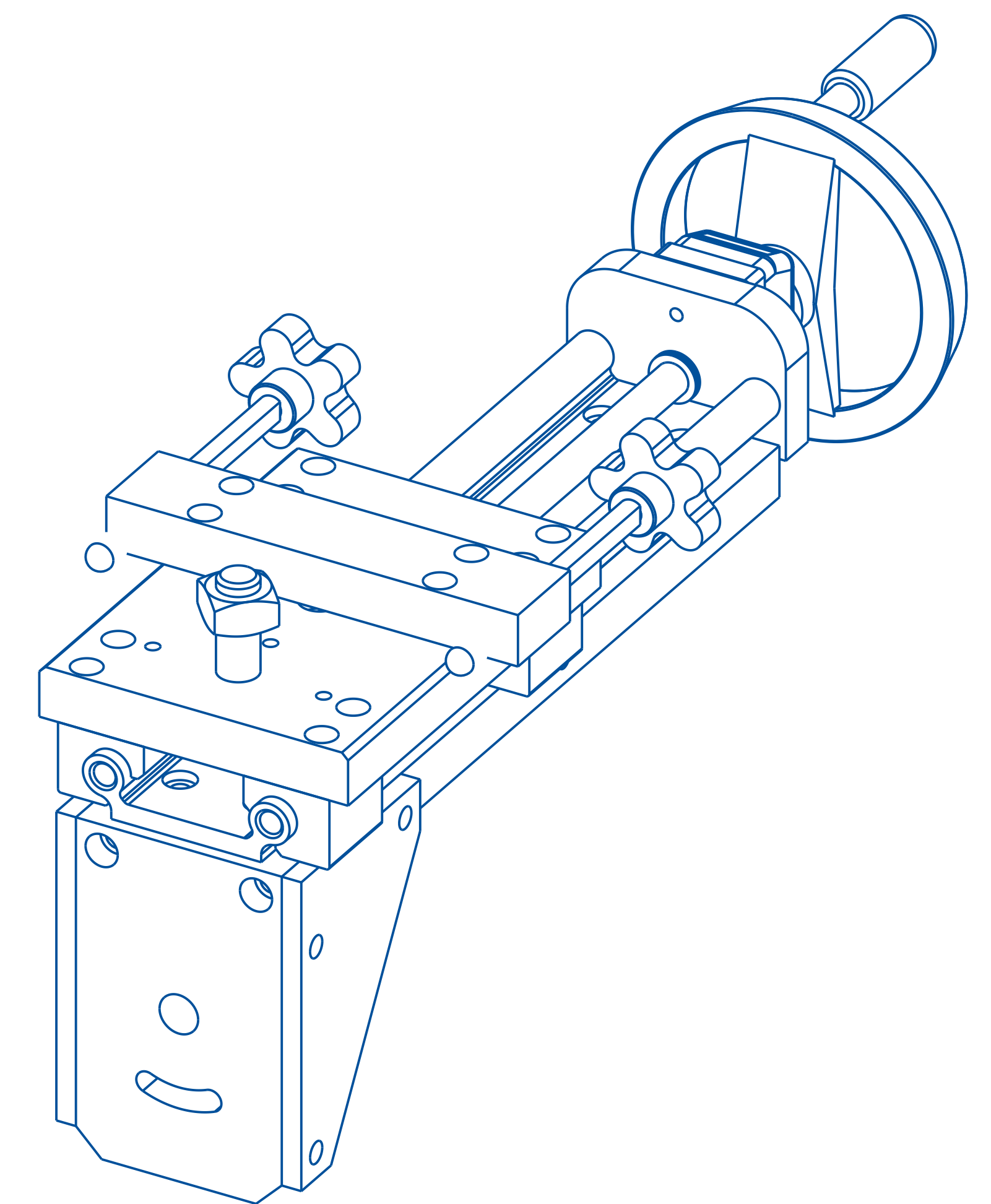
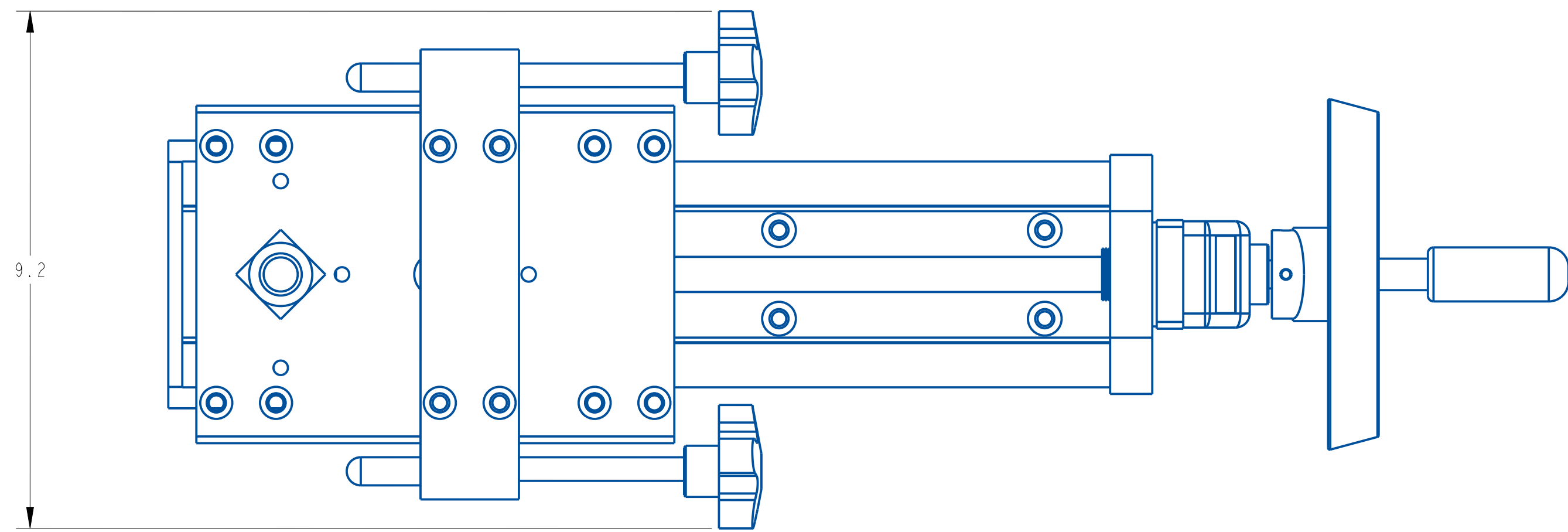

REV	DATE	DESCRIPTION	BY
A	Mar-10-25	NEW DRAWING	TAZ

THIS IS A PRO-ENGINEER DOCUMENT AND MAY NOT BE MODIFIED MANUALLY

<small>UNLESS OTHERWISE SPECIFIED DIMENSIONAL TOLERANCE</small> X ± .1 XX ± .01 XXX ± .005 ANGLES ± .30° SURFACE FINISH 125 BREAK ALL EDGES .005/ .015 CORNER RADIUS .010/ .030 ALL ANGLES ARE 90°	 QUADREL LABELING SYSTEMS 7670 JENTHER DRIVE MENTOR, OHIO 44060 (440) 602-4700	SCALE: 1/2
		DATE: Mar-10-25
		DRW BY: TAZ
		CHK BY: 03/15/2025-SEM
YARDARM w/HORIZONTAL ADJUST		MAT'L
		84127H-000

ITEM	QTY	PART NO.	DESCRIPTION	PARENT ITEM
1	1	793045-000	DIAMOND KNURL KNOB	22824-000
2	1	A26179-000	KNOB STUD	22824-000
3	1	C21348-400	ADJUSTMENT PLATE	22824-000

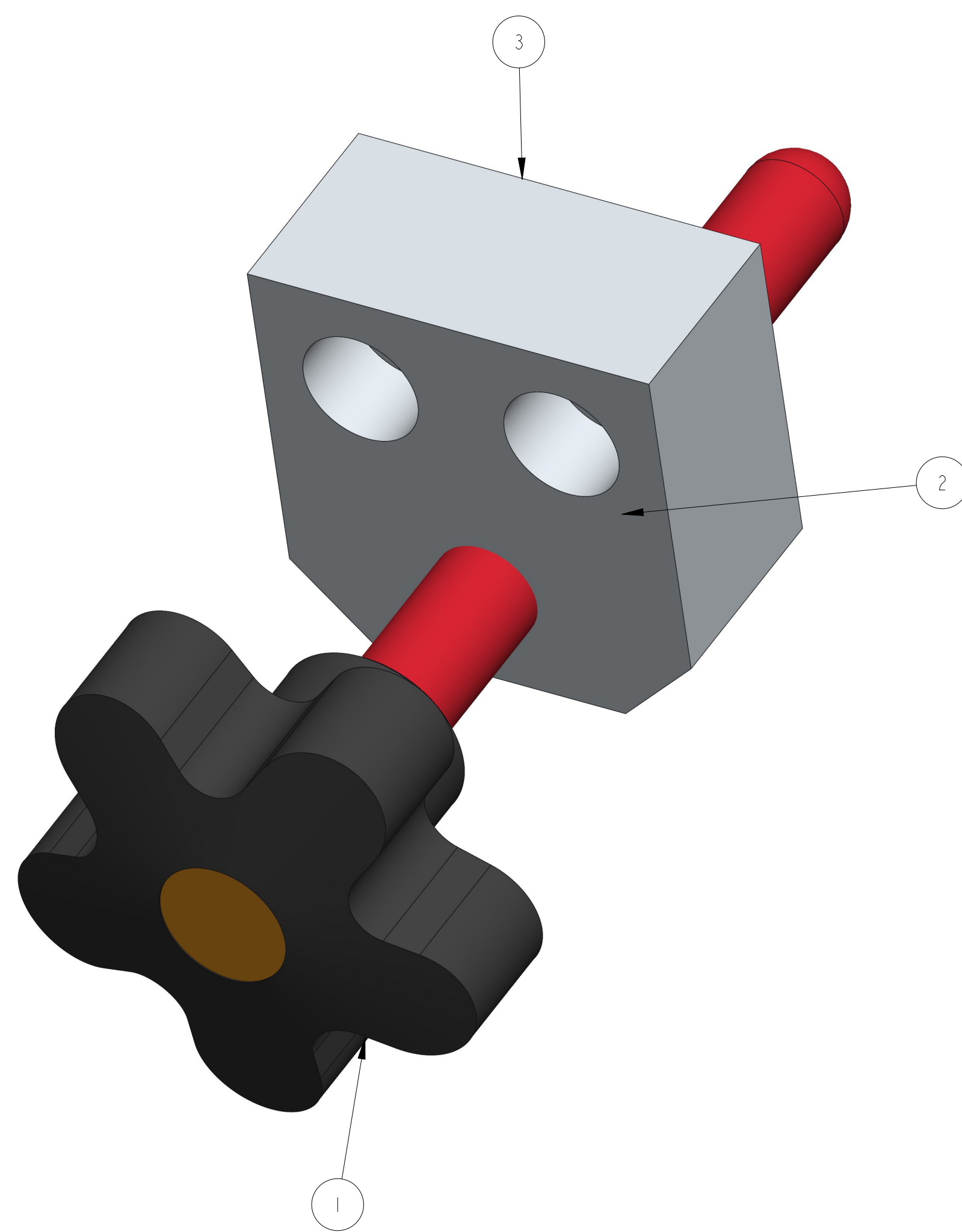

REV	DATE	DESCRIPTION	BY
A	21-FEB-2024	NEW DRAWING	CRT

THIS IS A PRO-ENGINEER DOCUMENT AND MAY NOT BE MODIFIED MANUALLY

UNLESS OTHERWISE SPECIFIED DIMENSIONAL TOLERANCE .X ± .1 .XX ± .01 .XXX ± .005 ANGLES ± 30°	QUADREL LABELING SYSTEMS 7670 JENTHER DRIVE MENTOR, OHIO 44060 (440) 602-4700		SCALE: 2/1 DATE: 21-FEB-2024 DRW BY: CRT CHK BY: 03/09/2024-SEM APPR BY:
	ADJUSTMENT BLOCK ASSEMBLY		
	SURFACE FINISH 125 BREAK ALL EDGES .005/0.15 CORNER RADIUS .010/0.30	MAT'L 22824-000	22824-000

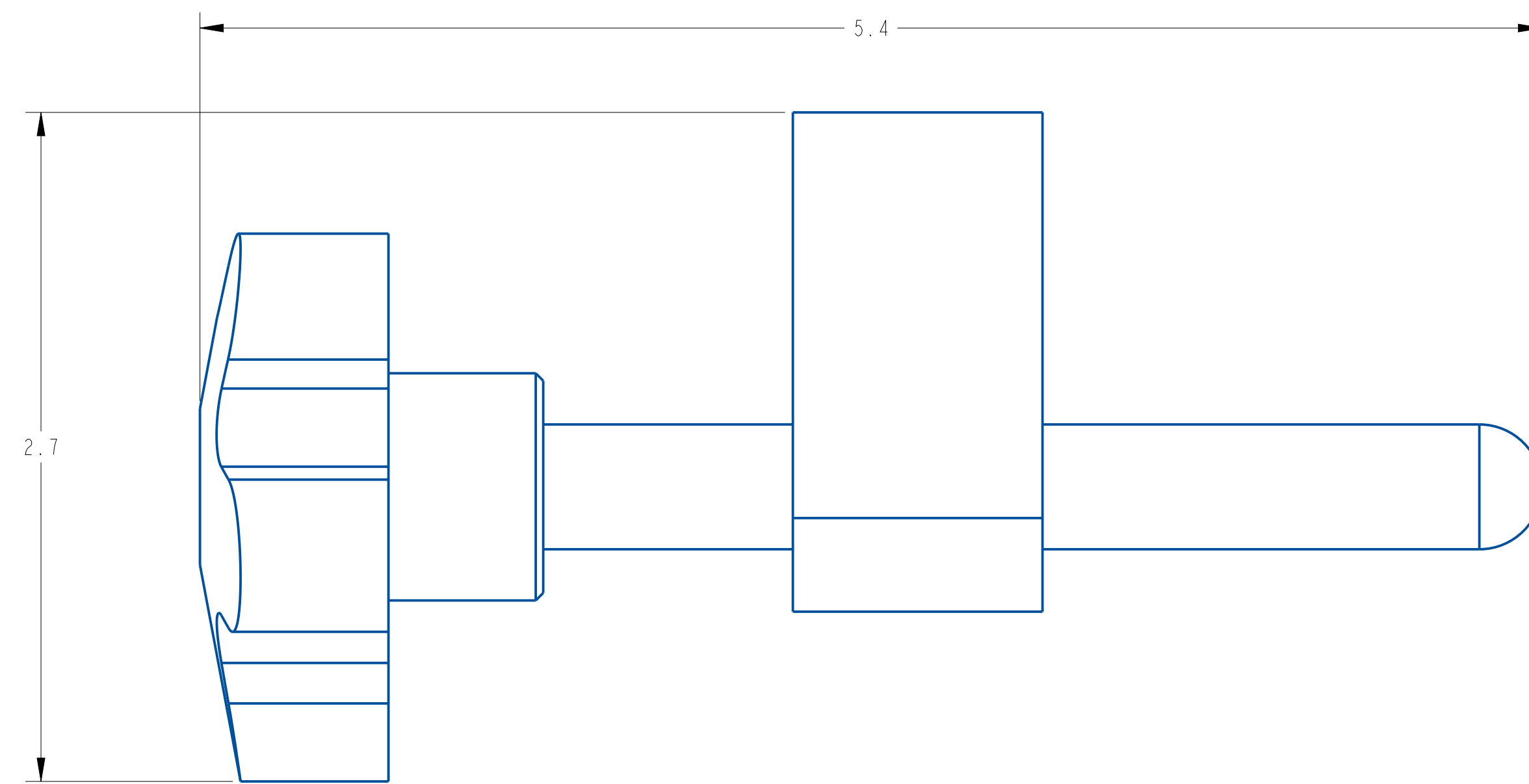
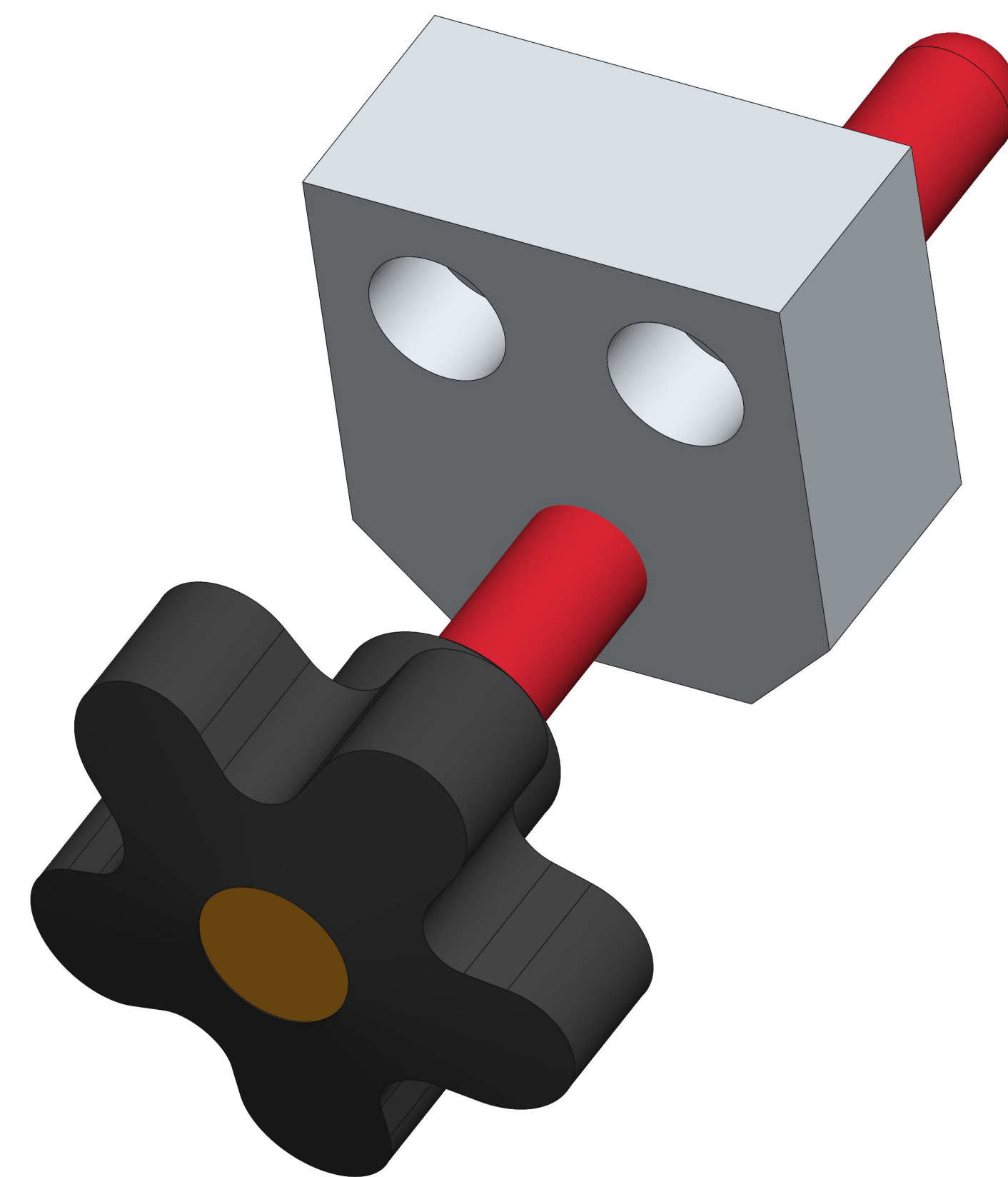
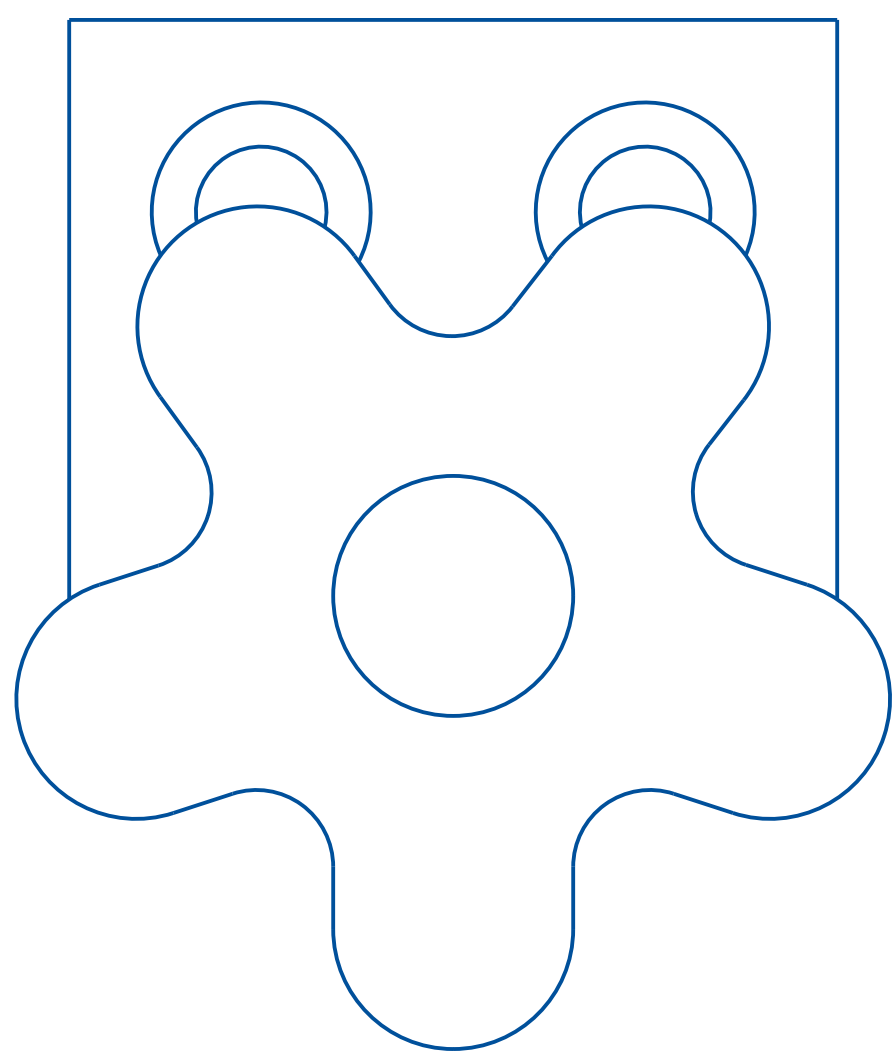
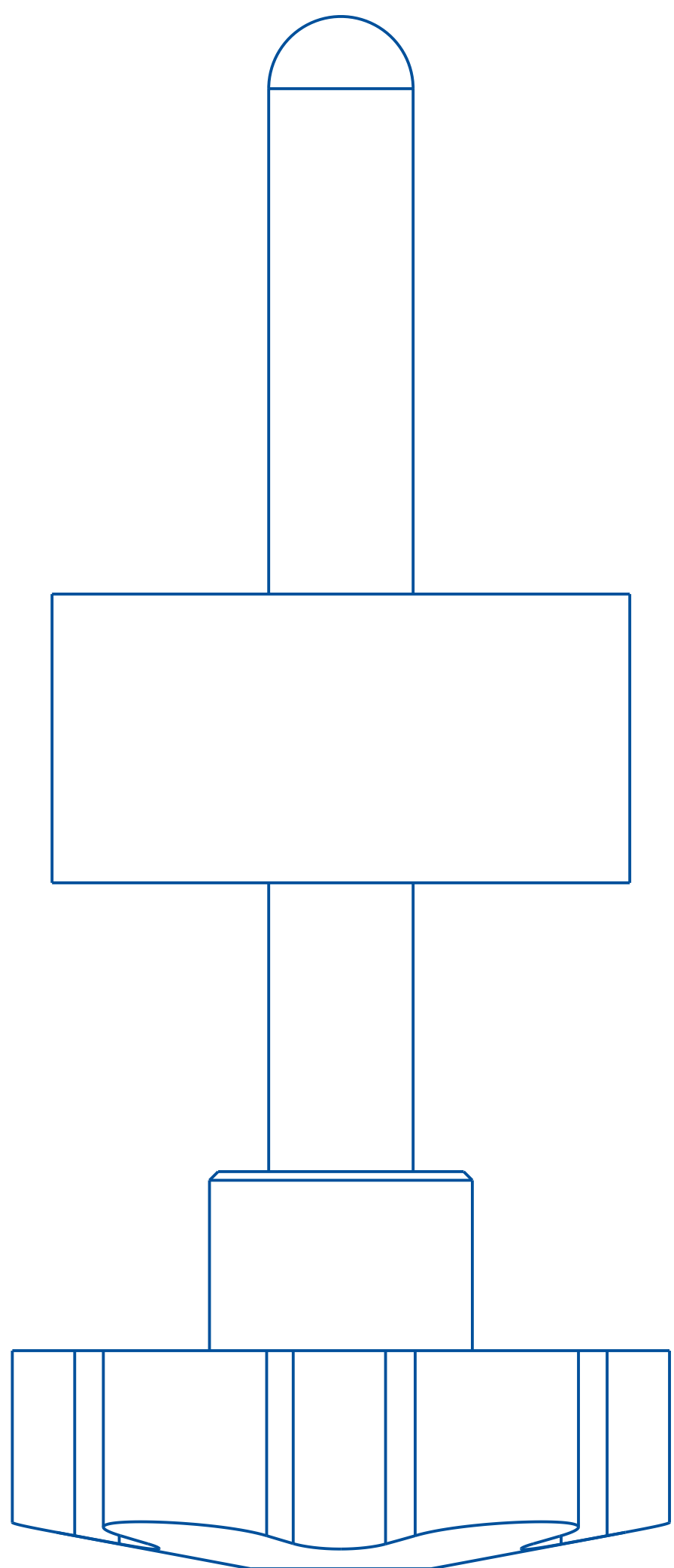

REV	DATE	DESCRIPTION	BY
A	21-FEB-2024	NEW DRAWING	CRT

THIS IS A PRO-ENGINEER DOCUMENT AND MAY NOT BE MODIFIED MANUALLY

UNLESS OTHERWISE SPECIFIED DIMENSIONAL TOLERANCE .x ± .1 .xx ± .01 .xxx ± .005 ANGLES ± 30°	QUADREL LABELING SYSTEMS 7670 JENTHER DRIVE MENTOR, OHIO 44060 (440) 602-4700		SCALE: 2/1 DATE: 21-FEB-2024 DRW BY: CRT CHK BY: 03/09/2024-SEM APPR BY:	
	ADJUSTMENT BLOCK ASSEMBLY			
	SURFACE FINISH 125 BREAK ALL EDGES .005/ .015 CORNER RADIUS .010/ .030	MAT'L 22824-000	22824-000	22824-000

ASSEMBLY TITLE: **YOKE ASSEMBLY**

DRAWING NO.:

GENERAL FUNCTION:

- The yoke assembly is the main mounting bracket assembly to mount the labeling head to the stand.
- Adjustments are provided to set the labeling head up for either top or side labeling applications.

SET UP AND ADJUSTMENTS:

- Loosen both locking handles to adjust the angular position of the labeling head.
- Re-tighten each handle when the correct angular position is set.

NOTE: Make sure each handle is secure, the labeling head is heavy and could rotate if the locking handles are not firmly secured.

MAINTENANCE:

- No scheduled maintenance for this assembly.

TROUBLESHOOTING:

Problem

- Labeler angular position moves

What To Do

- Secure locking tension by turning locking handles clock-wise

ITEM	QTY	PART NO.	DESCRIPTION	PARENT ITEM
1	2	801850-000	CLAMPING LEVER	22816-009
2	1	B21190-041	YOKE SIDE PLATE	22816-009
3	1	B21190-042	YOKE SIDE PLATE	22816-009
4	1	B21555-038	MTG YOKE BACK PLATE	22816-009

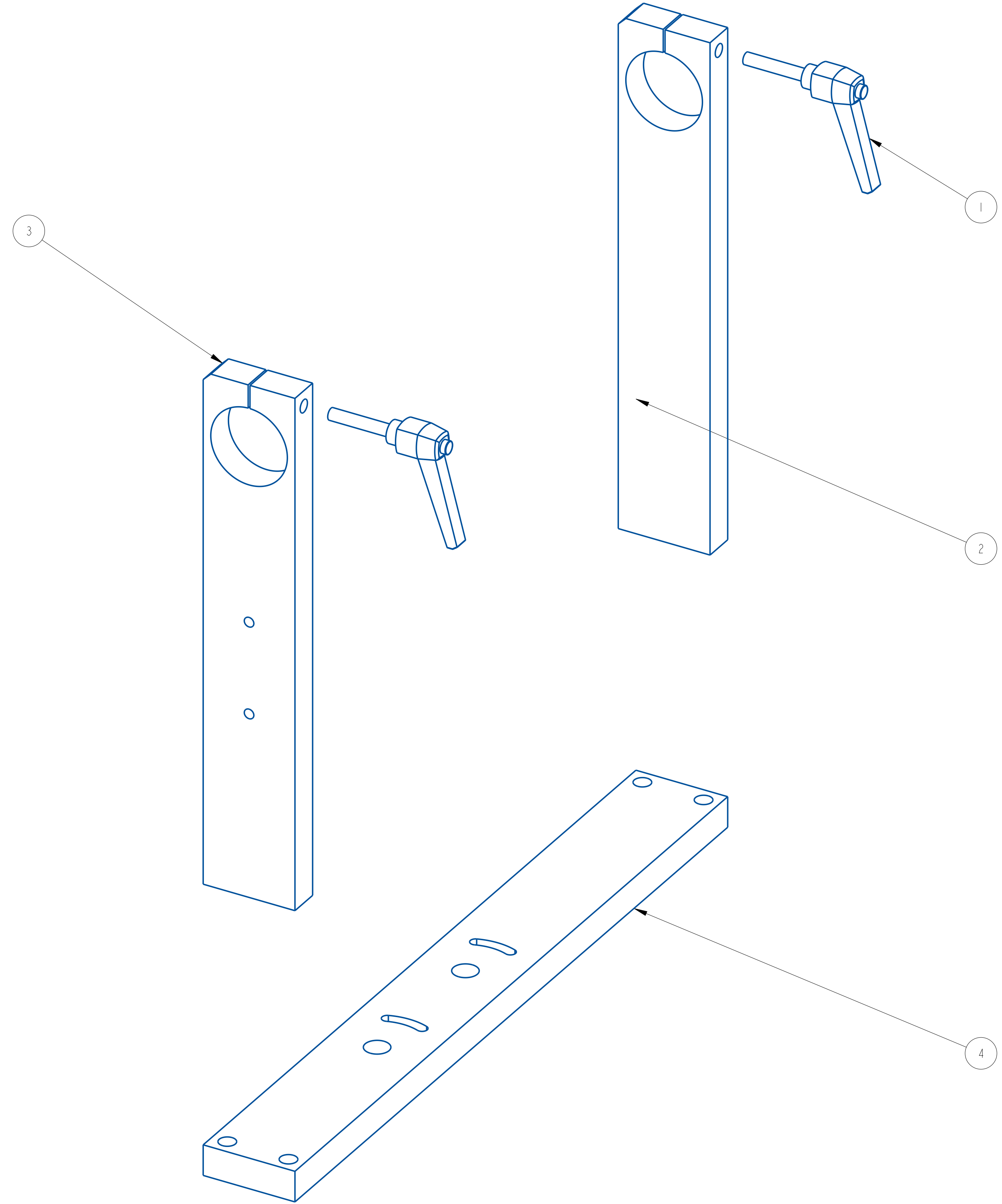

REV	DATE	DESCRIPTION	BY
A	Mar-10-25	NEW DRAWING	TAZ

THIS IS A PRO-ENGINEER DOCUMENT AND MAY NOT BE MODIFIED MANUALLY

QUADREL LABELING SYSTEMS
 7670 JENTHER DRIVE
 MENTOR, OHIO 44060
 (440) 602-4700

SCALE	DATE	DRW BY	CHK BY	APPR BY
1/2	Mar-10-25	TAZ		

MAT'L	QTY	PARENT ITEM
	22816-009	22816-009

UNLESS OTHERWISE SPECIFIED
 DIMENSIONAL TOLERANCE
 .X ± .1
 .XX ± .01
 .XXX ± .005
 ANGLES ± .30°
 SURFACE FINISH 125
 BREAK ALL EDGES .005/0.15
 CORNER RADIUS .010/0.30
 ALL ANGLES ARE 90°

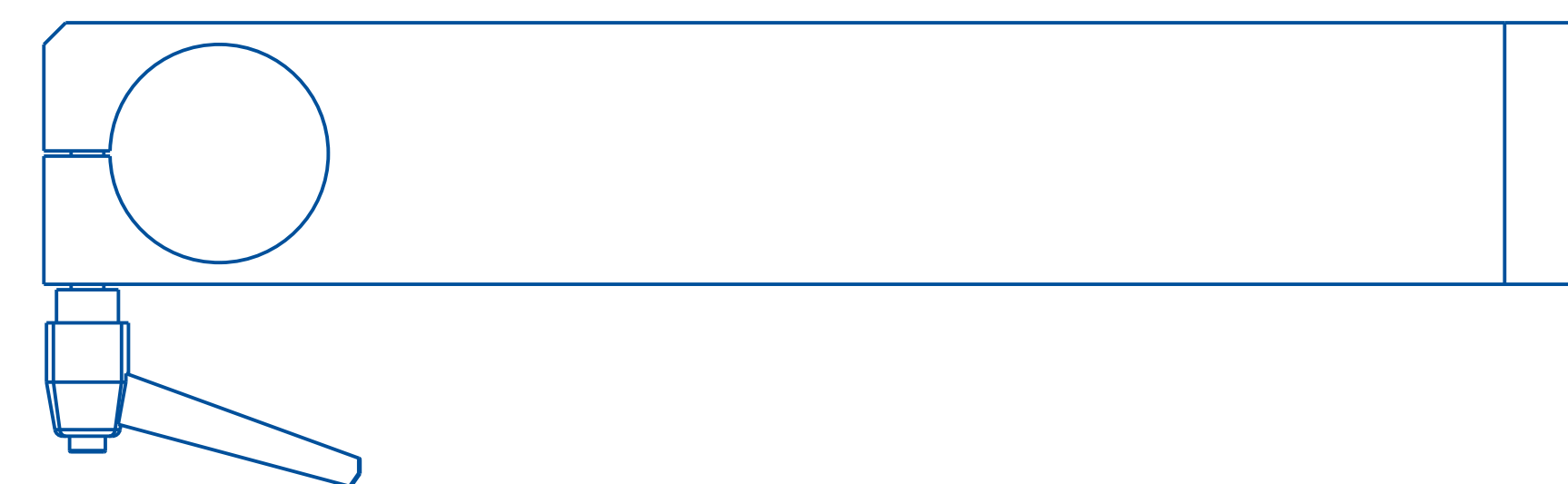
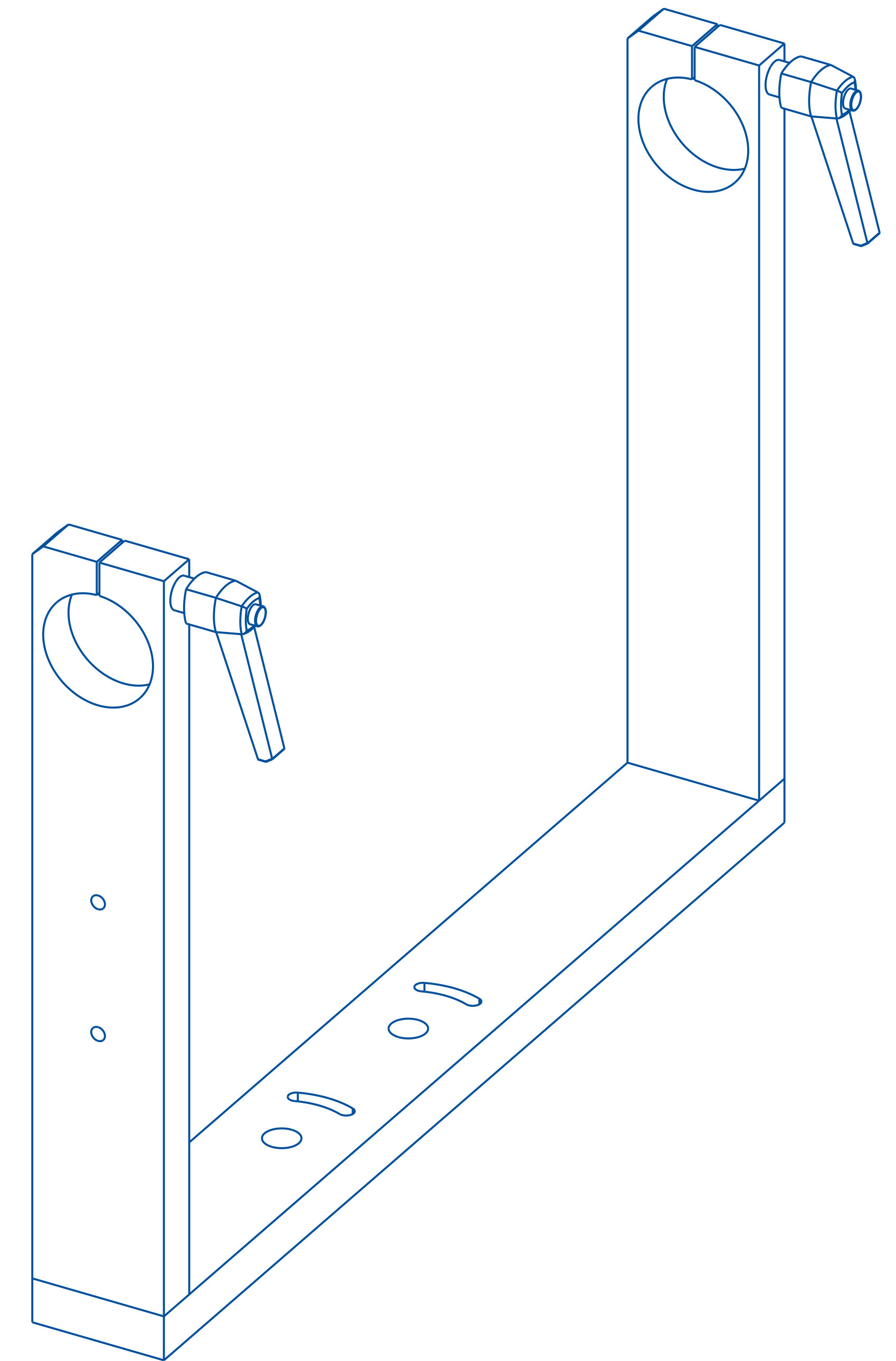
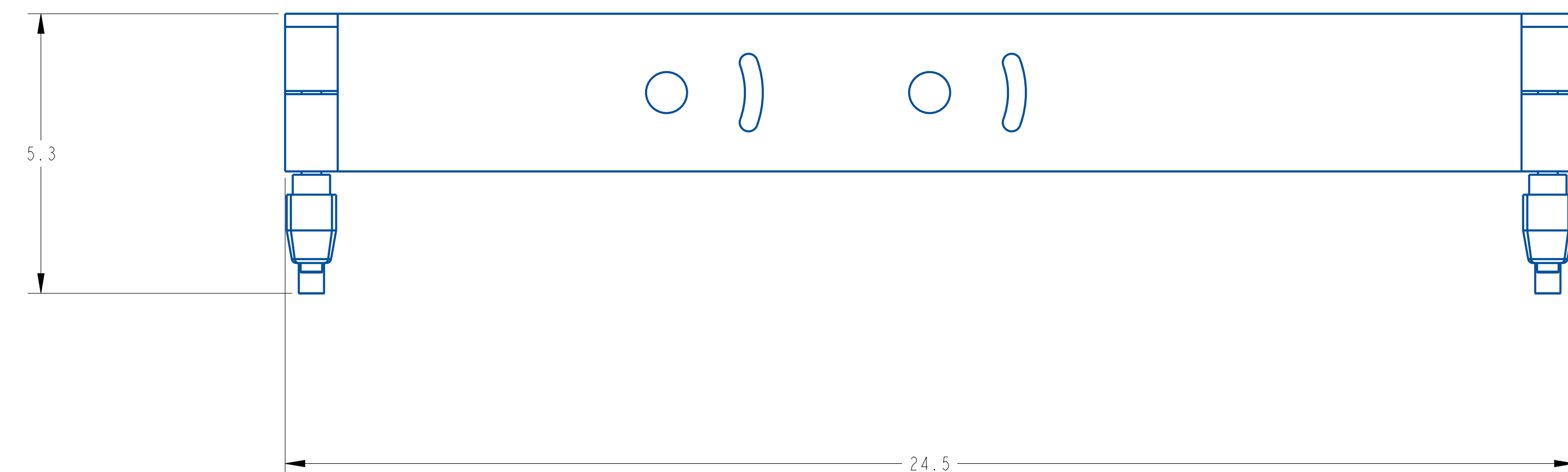
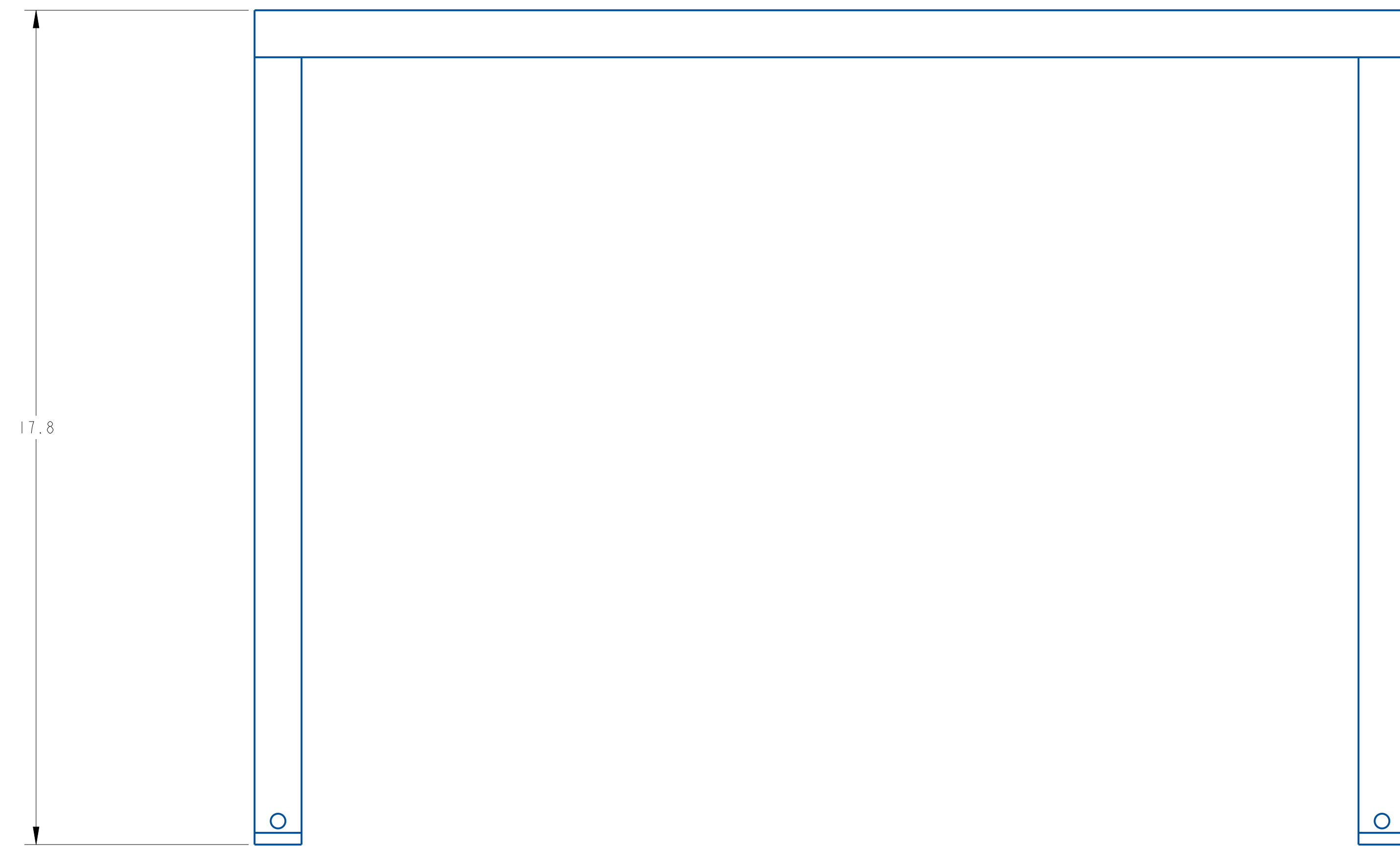

REV	DATE	DESCRIPTION	BY
A	Mar-10-25	NEW DRAWING	TAZ

THIS IS A PRO-ENGINEER DOCUMENT AND MAY NOT BE MODIFIED MANUALLY

UNLESS OTHERWISE SPECIFIED
DIMENSIONAL TOLERANCE
X ± .1
XX ± .01
XXX ± .005
ANGLES ± .30°
SURFACE FINISH 125
BREAK ALL EDGES .005/.015
CORNER RADIUS .010/.030
ALL ANGLES ARE 90°

QUADREL LABELING SYSTEMS
7670 JENTHER DRIVE
MENTOR, OHIO 44060
(440) 602-4700

SCALE: 1/2
DATE: Mar-10-25
DRW BY: TAZ
CHK BY: 03/15/2025-SEM
APPR BY:
Q60 YOKE ASSEMBLY
MAT'L 22816-009 22816-009

ITEM	QTY	PART NO.	DESCRIPTION	PARENT ITEM
1	2	801850-000	CLAMPING LEVER	22816-015
2	1	B21190-041	YOKE SIDE PLATE	22816-015
3	1	B21190-042	YOKE SIDE PLATE	22816-015
4	1	B21555-034	MTG YOKE BACK PLATE	22816-015

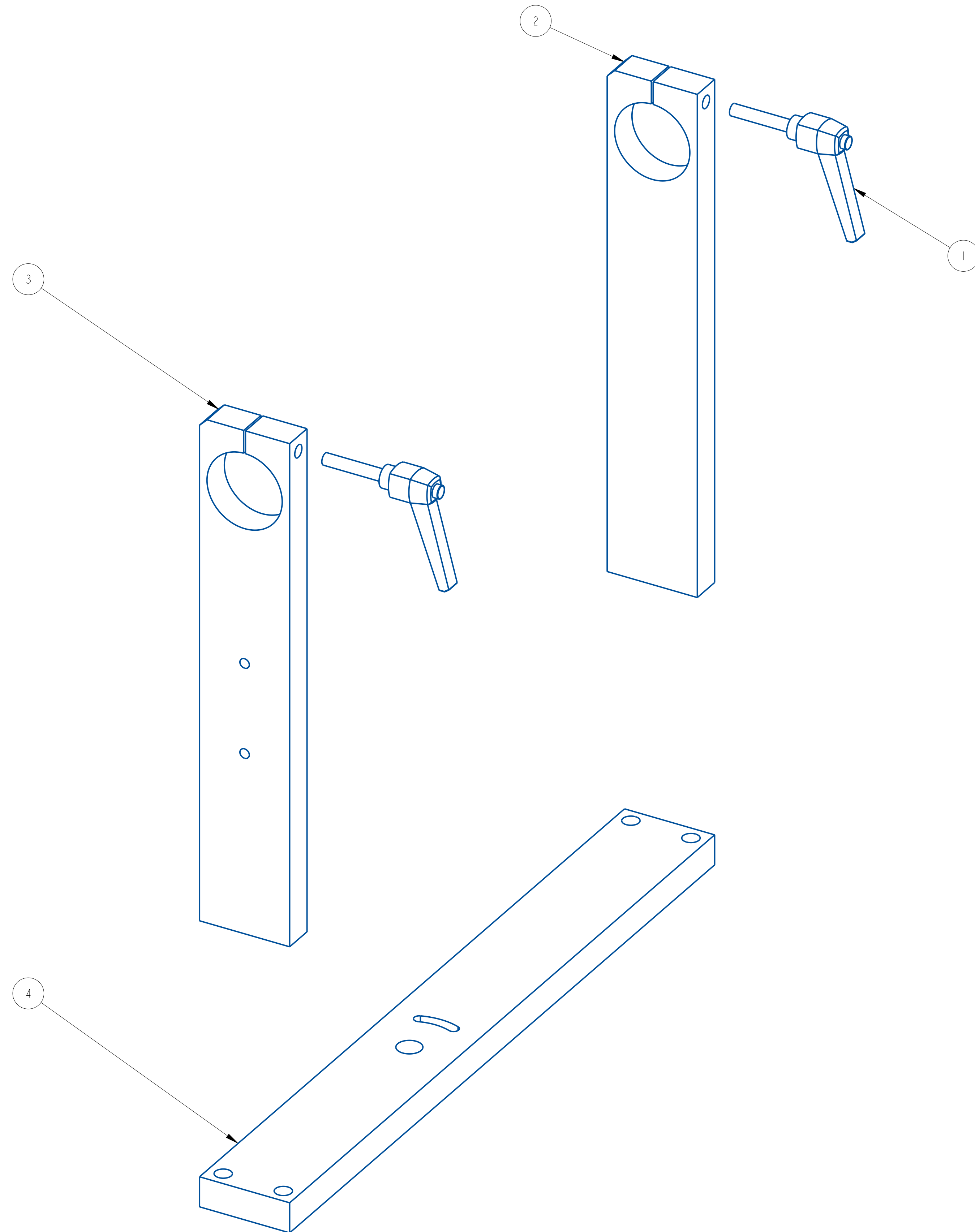

REV	DATE	DESCRIPTION	BY
A	Jan-09-26	NEW DRAWING	TAZ

THIS IS A PRO-ENGINEER DOCUMENT AND MAY NOT BE MODIFIED MANUALLY

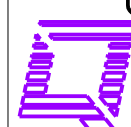
UNLESS OTHERWISE SPECIFIED DIMENSIONAL TOLERANCE .X ± .1 .XX ± .01 .XXX ± .005 ANGLES ± .30° SURFACE FINISH 125 BREAK ALL EDGES .005/ .015 CORNER RADIUS .010/ .030 ALL ANGLES ARE 90°	 7670 JENTHER DRIVE MENTOR, OHIO 44060 (440) 602-4700	SCALE: 1/2
		DATE: Jan-09-26
		DRW BY: TAZ
		CHK BY:
Q60 YOKE ASSEMBLY		APPR BY:
MAT'L	22816-015	22816-015

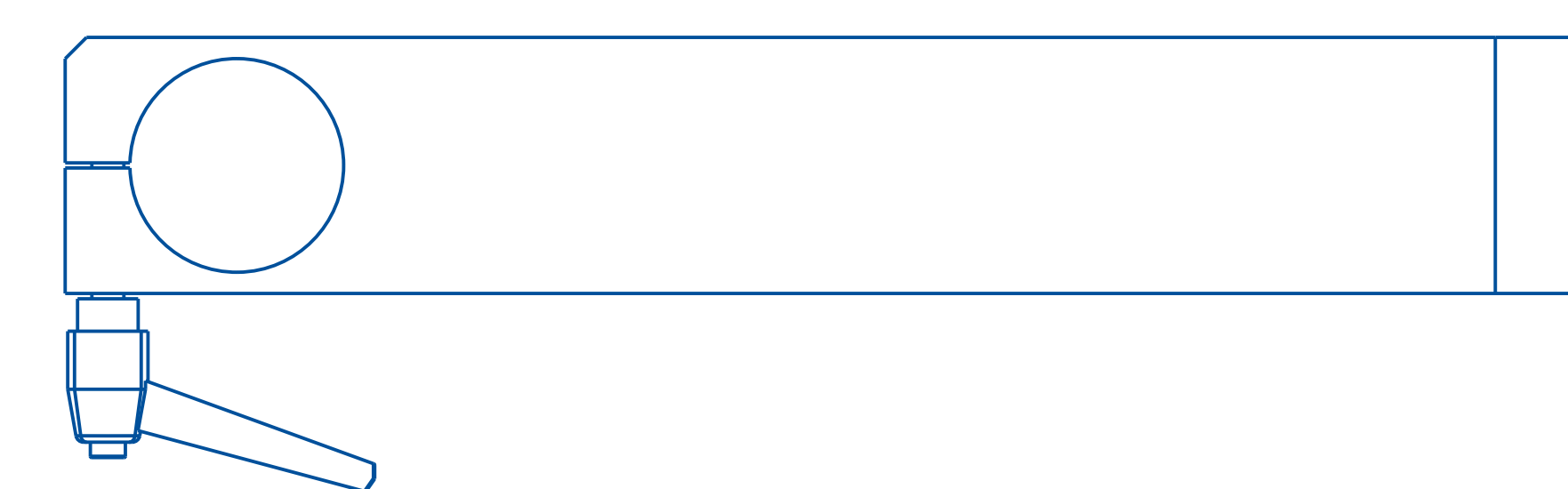
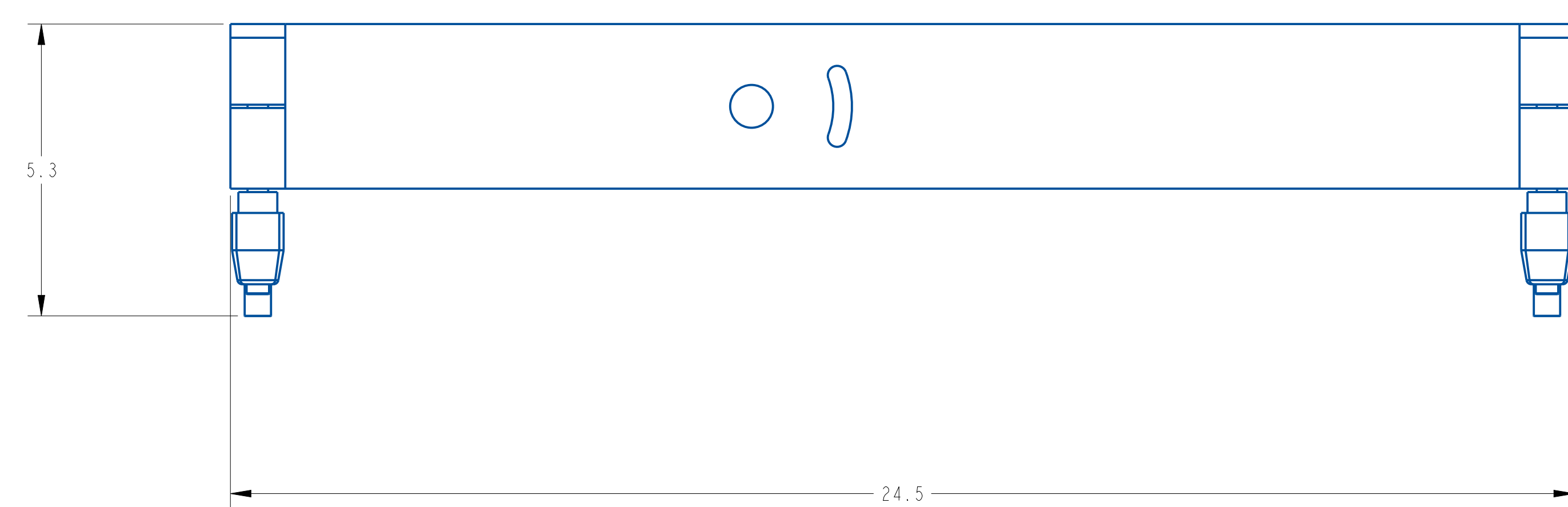
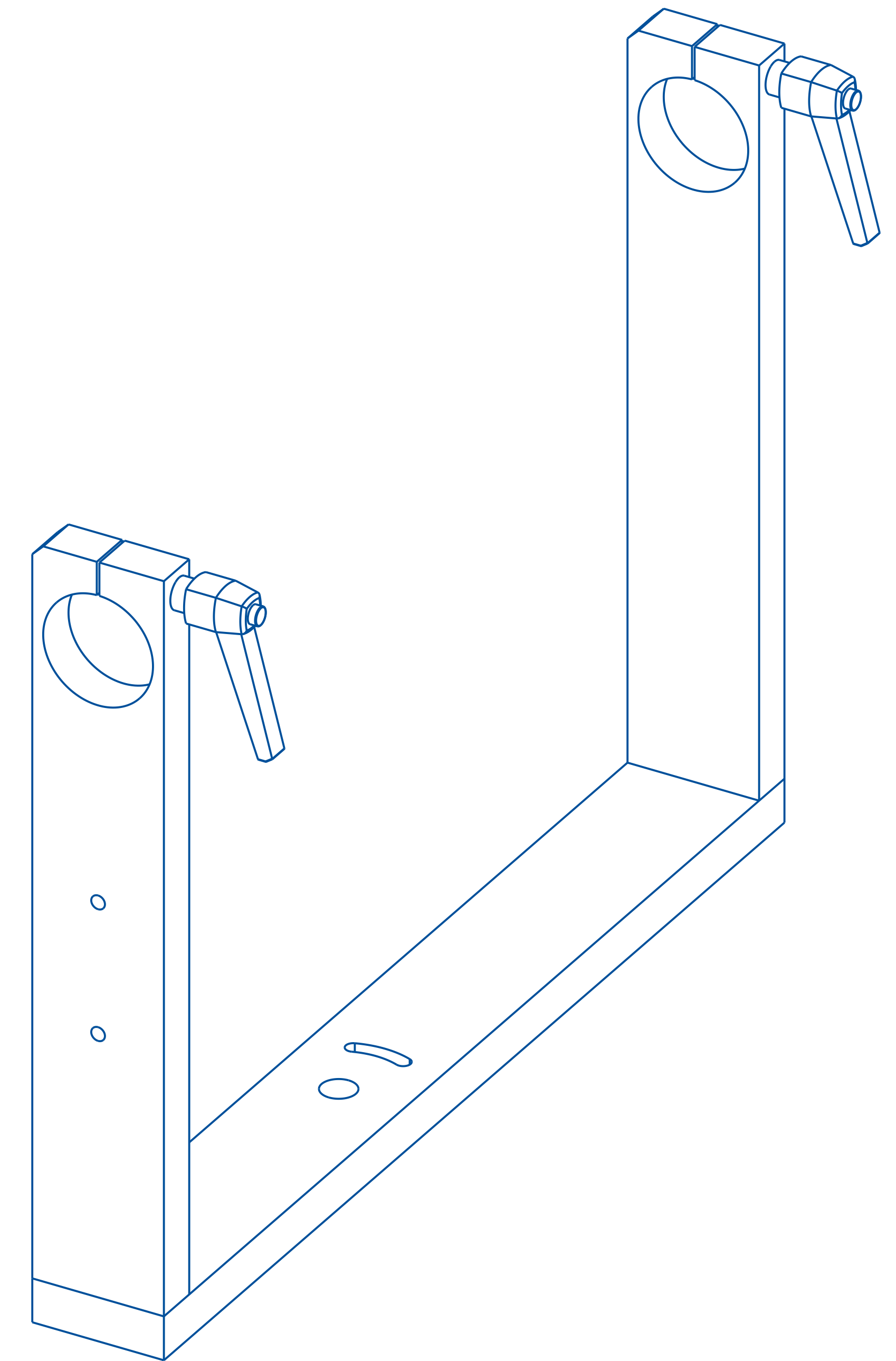
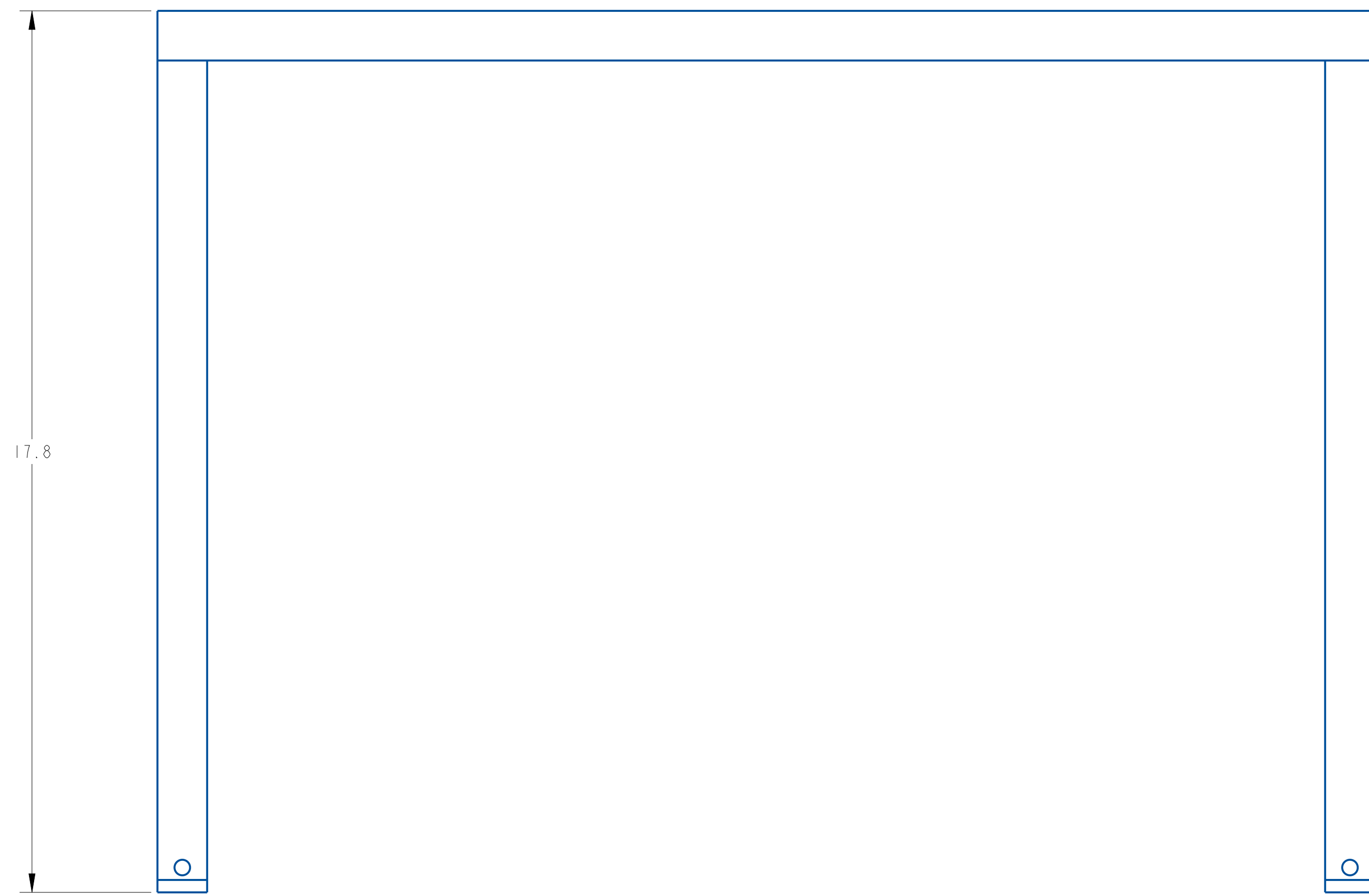

REV	DATE	DESCRIPTION	BY
A	Jan-09-26	NEW DRAWING	TAZ

THIS IS A PRO-ENGINEER DOCUMENT AND MAY NOT BE MODIFIED MANUALLY

QUADREL LABELING SYSTEMS
 7670 JENTHER DRIVE
 MENTOR, OHIO 44060
 (440) 602-4700

SCALE: 1/2
 DATE: Jan-09-26
 DRW BY: TAZ
 CHK BY:
 APPR BY:

Q60 YOKE ASSEMBLY

MAT'L 22816-015 22816-015

ASSEMBLY TITLE: CORNER WIPE ASSEMBLY

GENERAL FUNCTION:

The trailing panel corner wipe applies the remaining label to the trailing panel of the product. It is controlled through the operator's touch screen. As the product passes the applicator product detection sensor, the trailing panel wipe LD delay setting will determine when the cylinder extends to wipe the label. The wipe delay setting will determine the length of time the cylinder extends to reach the full label wipe requirement.

SET UP AND ADJUSTMENTS:

The cylinder requires a minimum of 30 psi to extend.

MAINTENANCE:

-Clean all the parts that may acquire labels or glue residue.

ITEM	QTY	PART NO.	DESCRIPTION	PARENT ITEM
1	2	A20904-000	RAIL SPACER, 1/2"	21712-009
2	1	A21121-101	RAIL	21712-009
3	1	B21190-055	SECONDARY WIPE SIDE PLATE	21712-009
4	1	B21191-021	TRAILING WIPE MOUNTING PLATE	21712-009

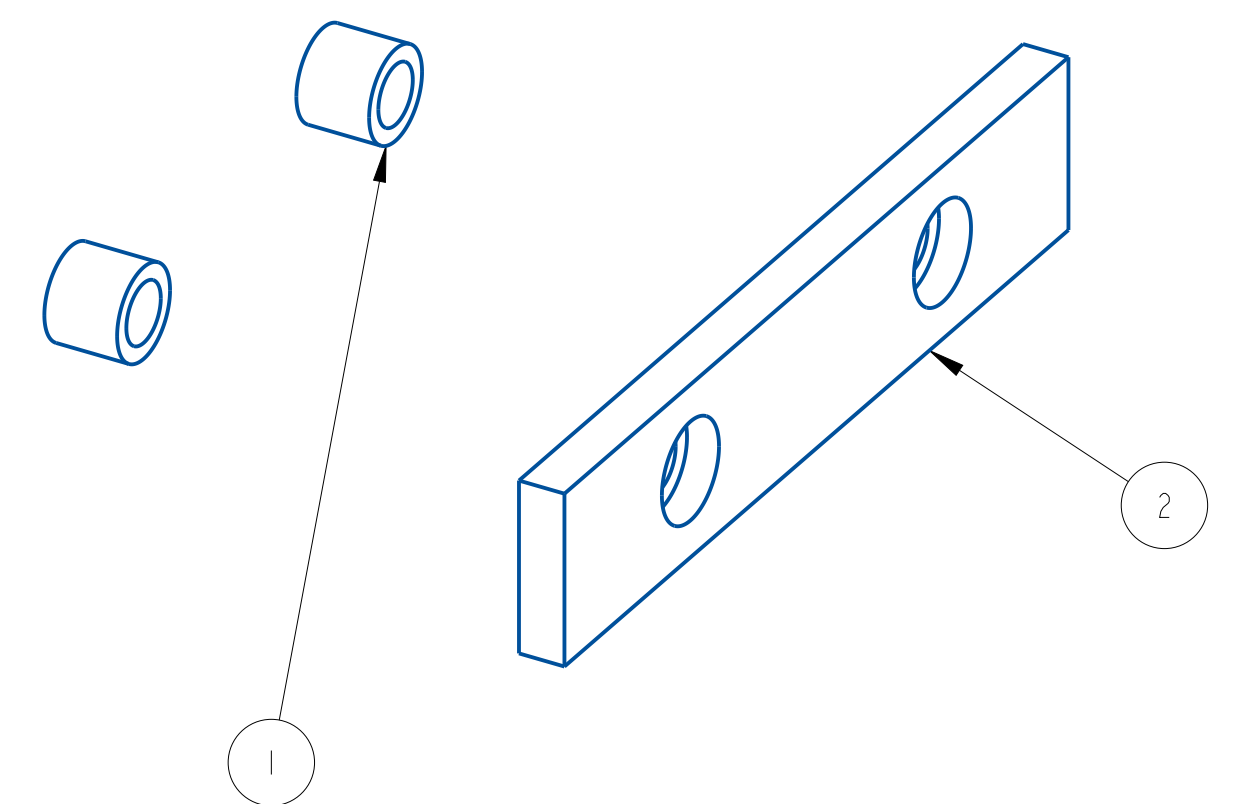
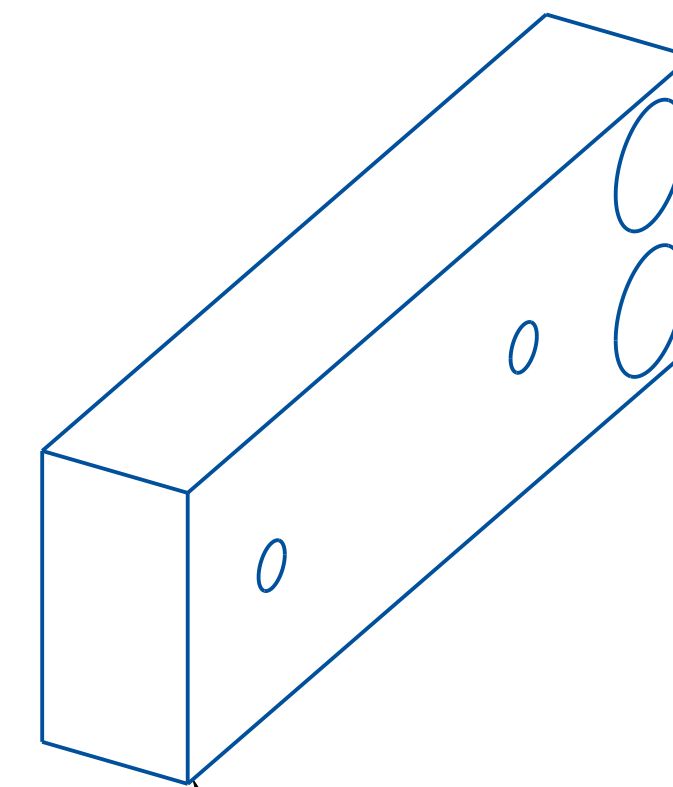
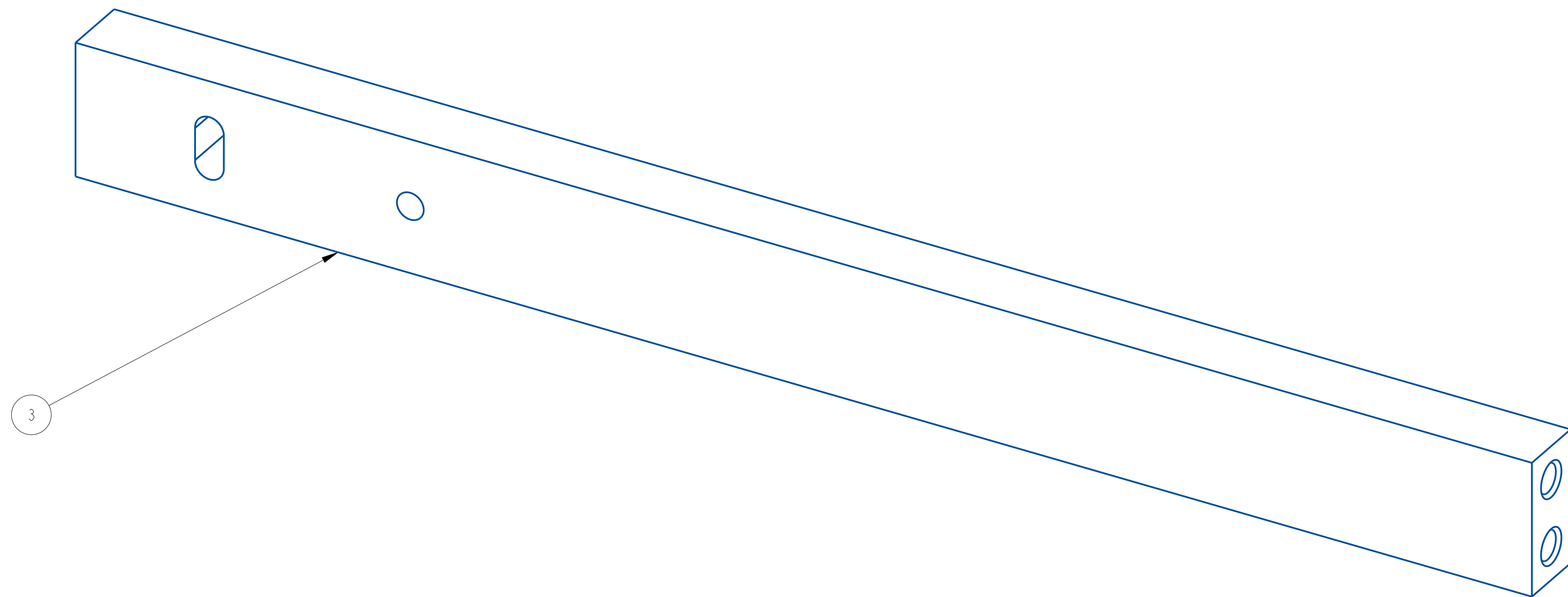

REV	DATE	DESCRIPTION	BY
A	Mar-10-25	NEW DRAWING	TAZ

THIS IS A PRO-ENGINEER DOCUMENT AND MAY NOT BE MODIFIED MANUALLY

UNLESS OTHERWISE SPECIFIED
 DIMENSIONAL TOLERANCE
 X ± .1
 XX ± .01
 XXX ± .005
 ANGLES ± .30°

SURFACE FINISH 125
 BREAK ALL EDGES .005/ .015
 CORNER RADIUS .010/ .030
 ALL ANGLES ARE 90°

QUADREL LABELING SYSTEMS
 7670 JENTHER DRIVE
 MENTOR, OHIO 44060
 (440) 602-4700

SCALE: 7/8
 DATE: Mar-10-25
 DRW BY: TAZ
 CHK BY: 03/15/2025-SEM
 APPR BY:

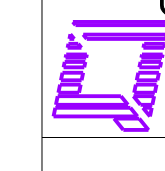

Q60 TRAILING IMPERSSOR MOUNT
 MAT'L 21712-009

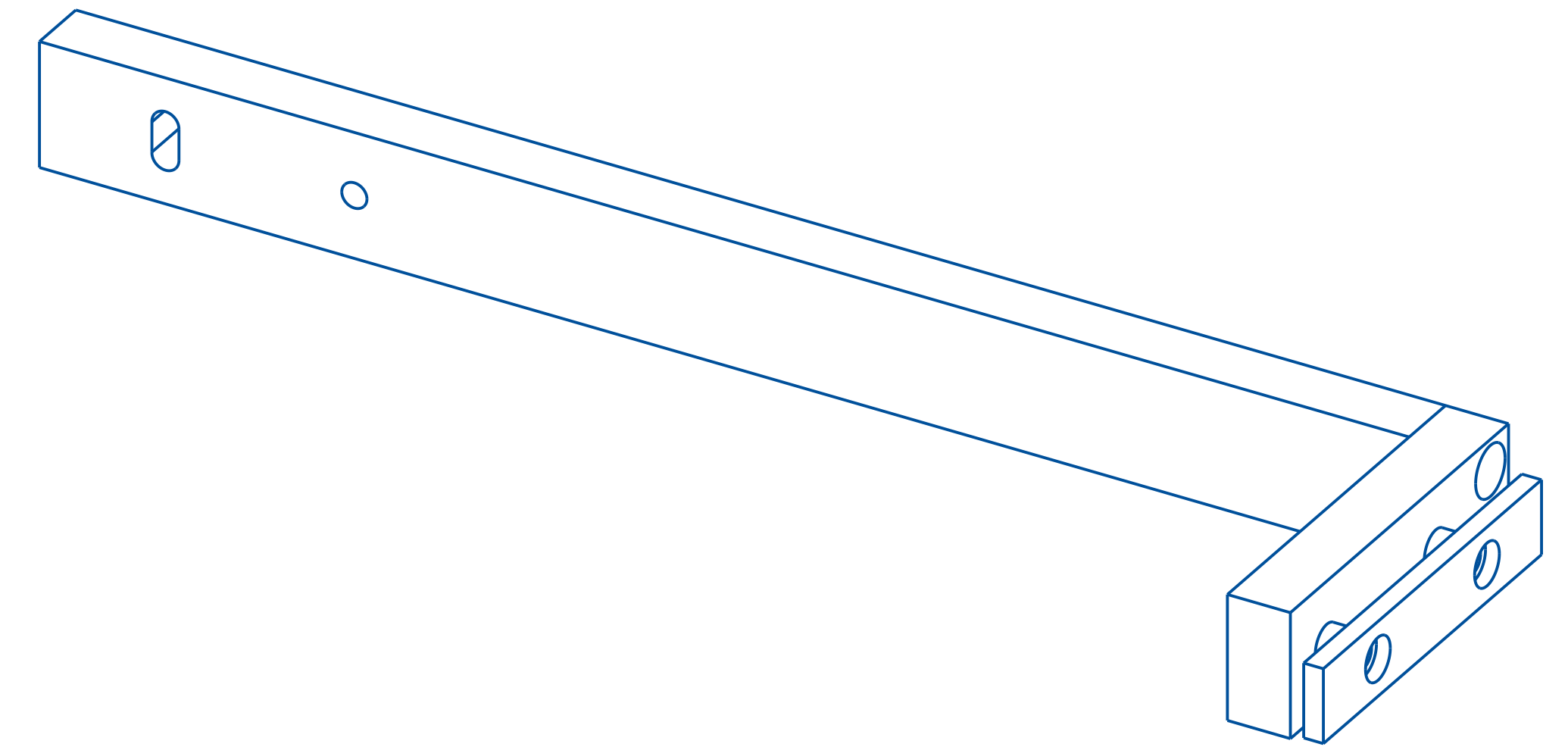
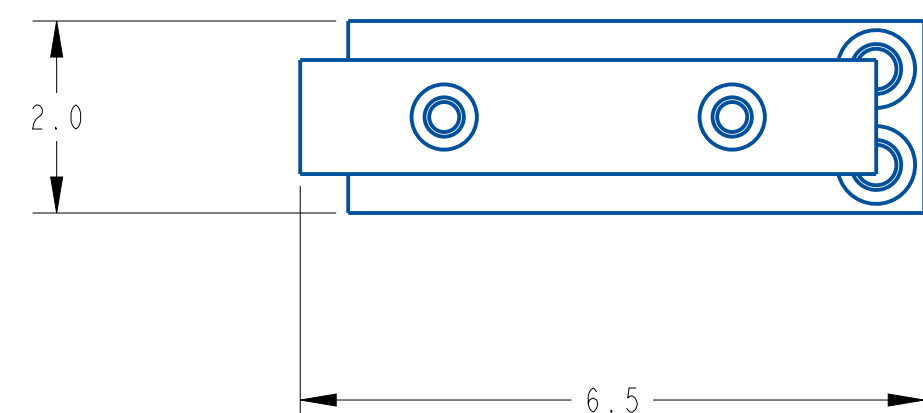
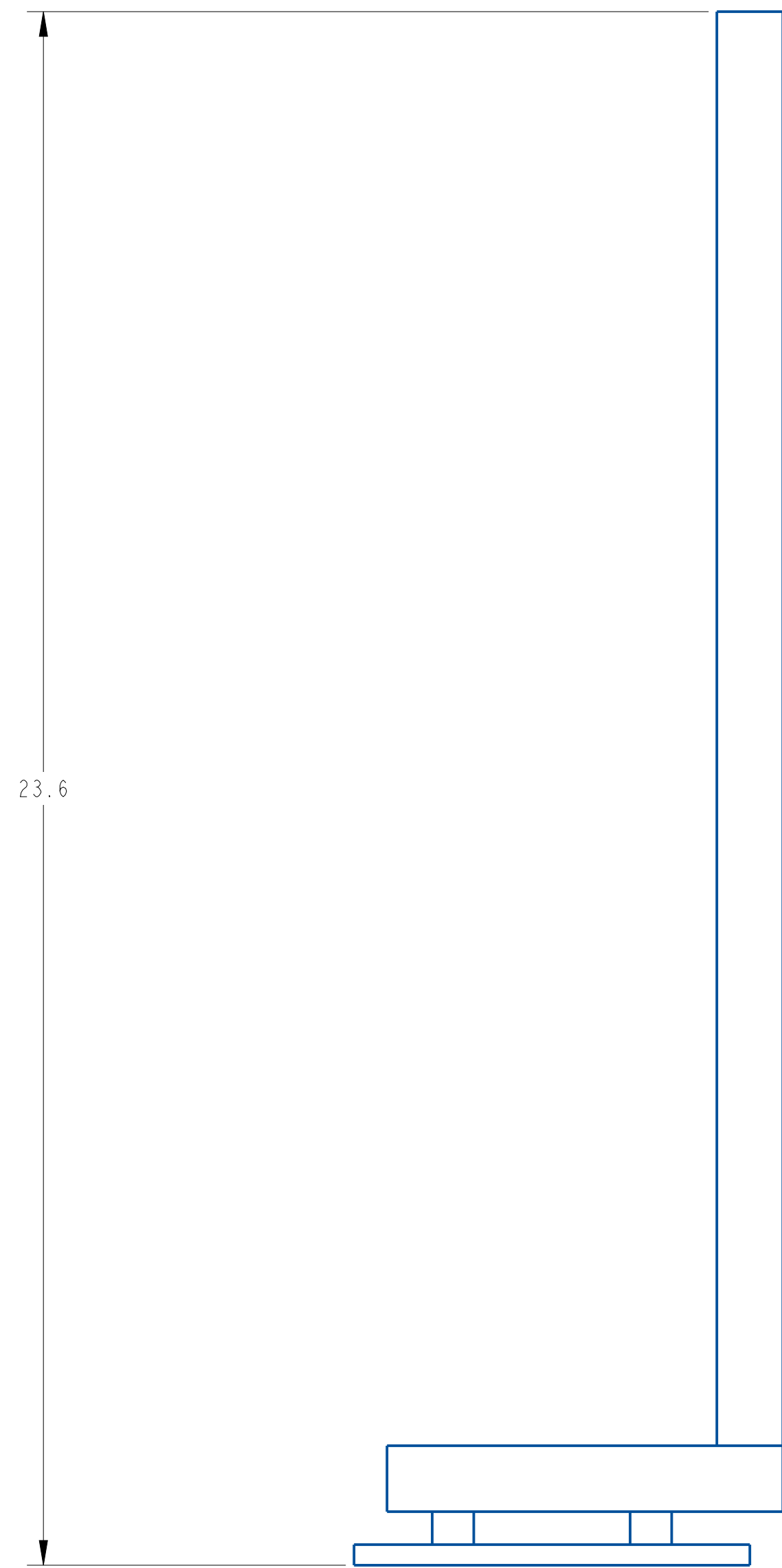

REV	DATE	DESCRIPTION	BY
A	Mar-10-25	NEW DRAWING	TAZ

THIS IS A PRO-ENGINEER DOCUMENT AND MAY NOT BE MODIFIED MANUALLY

UNLESS OTHERWISE SPECIFIED
 DIMENSIONAL TOLERANCE
 X ± .1
 XX ± .01
 XXX ± .005
 ANGLES ± .30°
 SURFACE FINISH 125
 BREAK ALL EDGES .005/ .015
 CORNER RADIUS .010/ .030
 ALL ANGLES ARE 90°

QUADREL LABELING SYSTEMS
 7670 JENTHER DRIVE
 MENTOR, OHIO 44060
 (440) 602-4700

SCALE: 1/2
 DATE: Mar-10-25
 DRW BY: TAZ
 CHK BY: 03/15/2025-SEM
 APPR BY:

Q60 TRAILING IMPERSSOR MOUNT

MAT'L

21712-009

ITEM	QTY	PART NO.	DESCRIPTION	PARENT ITEM
1	1	393586-000	PNEUMATIC SLIDE	21712-012
2	1	A20688-000	LOCKING CLAMP	21712-012
3	1	A20689-000	LOCKING CLAMP	21712-012
4	1	A20844-000	GUIDE RAIL CLAMP BAR	21712-012
5	2	A21368-000	GUIDE RAIL CLAMP BAR	21712-012
6	1	A21691-000	MOUNTING BLOCK	21712-012
7	1	A22442-000	RAIL MOUNTING PLATE	21712-012
8	1	A23920-001	VERTICAL ADJUST ROD	21712-012

NOT SHOWN:
A23922-002 MODIFIED BRUSH BLOCK
791792-000 2" NYLON BRISTLE BRUSH - 12"
A24354-413 SPRING STEEL IMPRESSOR
791885-000 CROSS CLAMP

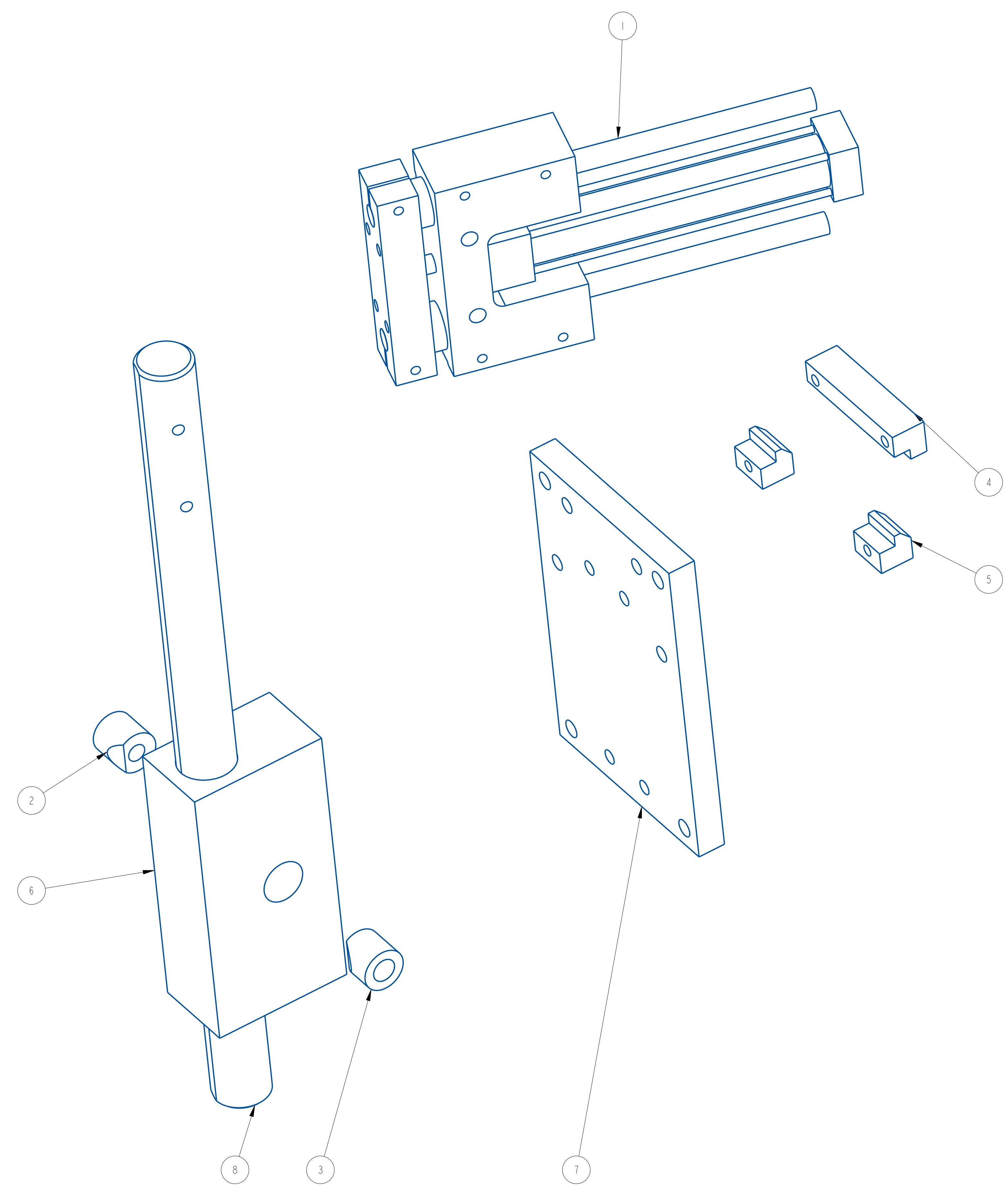

A		May-07-25	NEW DRAWING	TAZ
REV	DATE	DESCRIPTION	BY	

THIS IS A PRO-ENGINEER DOCUMENT AND MAY NOT BE MODIFIED MANUALLY

UNLESS OTHERWISE SPECIFIED DIMENSIONAL TOLERANCE X ± .1 XX ± .01 XXX ± .005 ANGLES ± .30° SURFACE FINISH 125 BREAK ALL EDGES .005/0.15 CORNER RADIUS .010/0.30	QUADREL LABELING SYSTEMS 7670 JENTHER DRIVE MENTOR, OHIO 44060 (440) 602-4700		SCALE: 1/1
			DATE: May-07-25
			DRW BY: TAZ
			CHK BY: APPR BY:
CORNER PANEL TRAILING WIPE, 4"			
MAT'L	21712-012	21712-012	

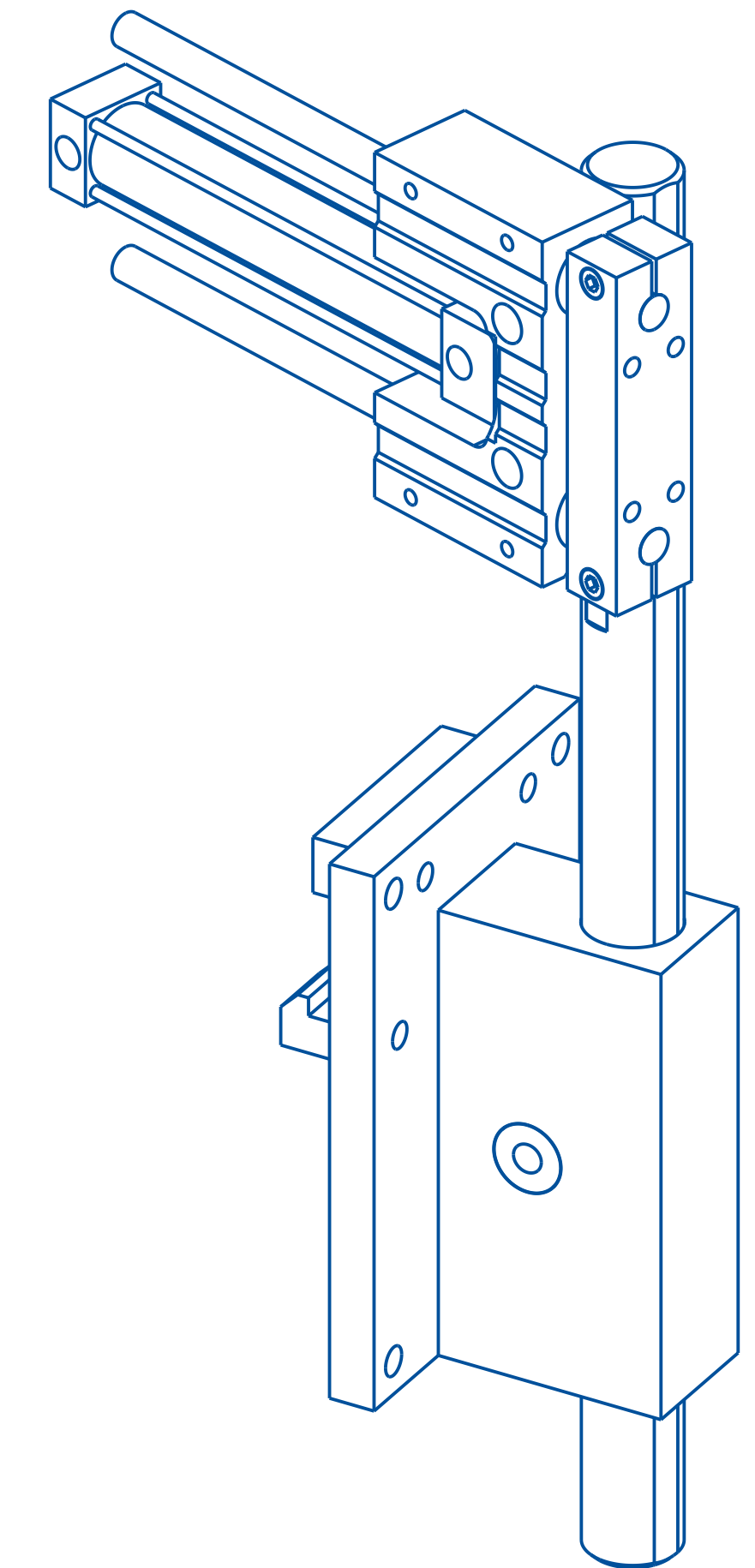
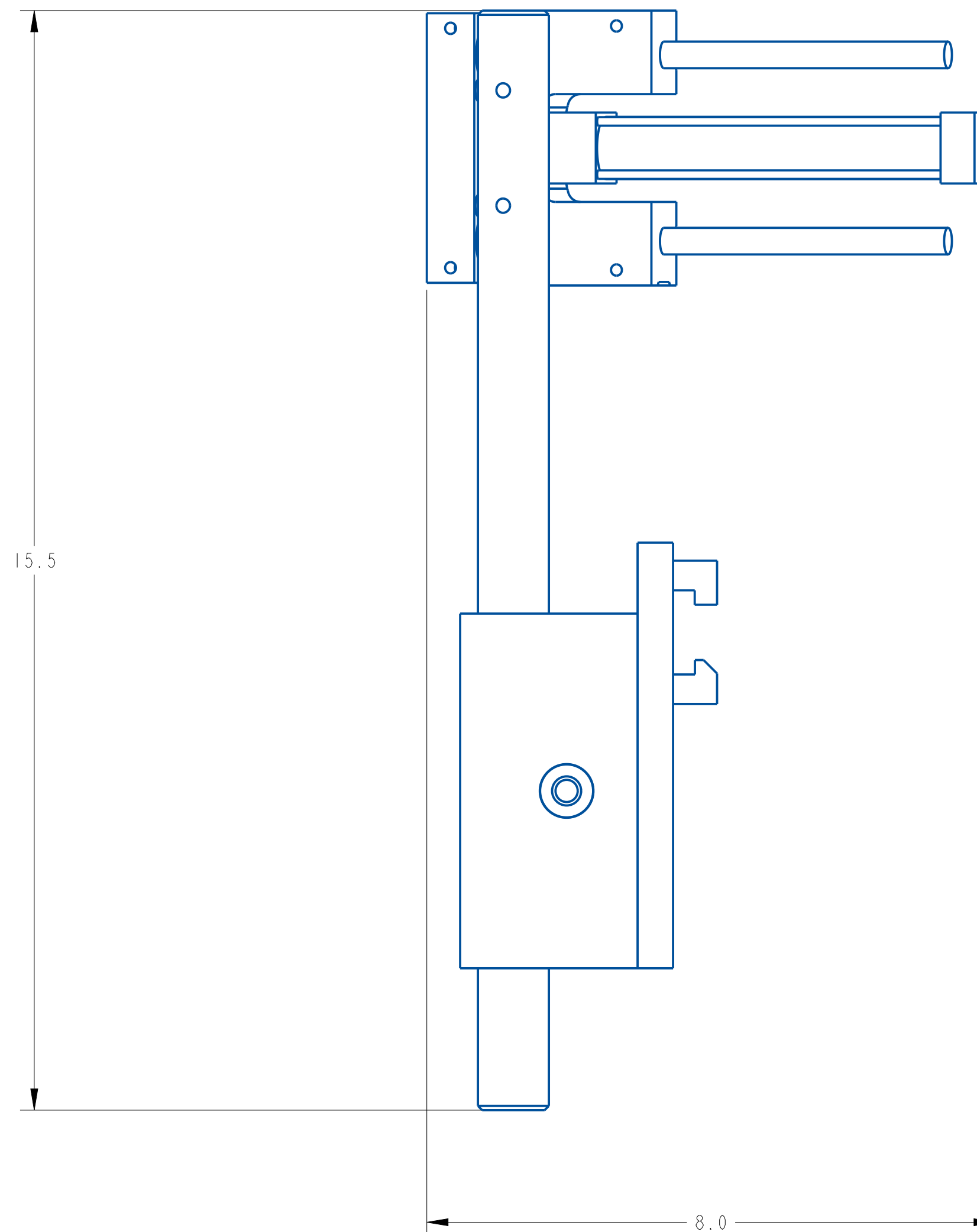
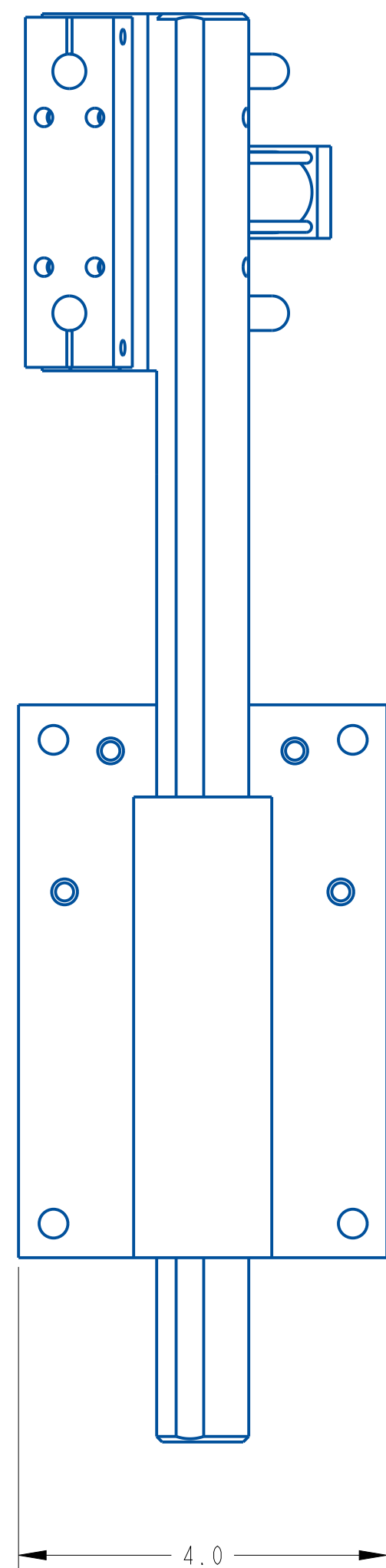
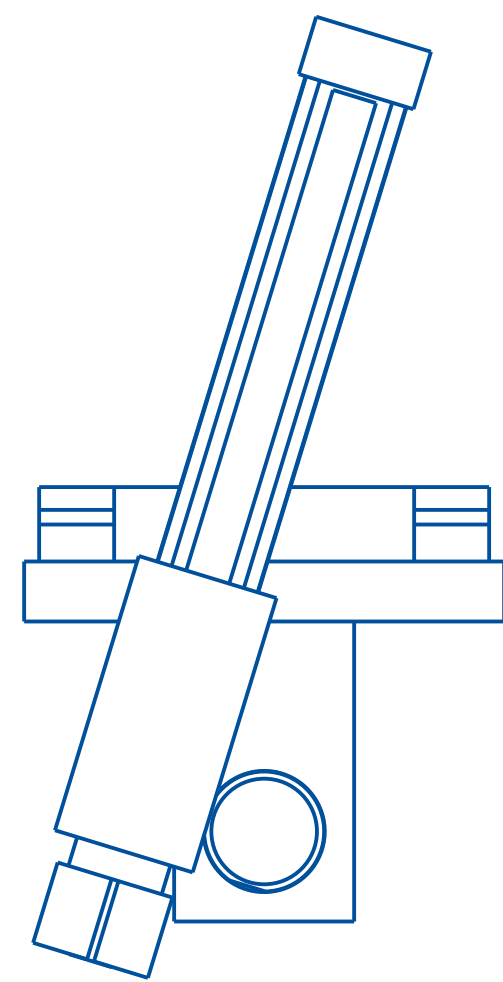

THIS IS A PRO-ENGINEER DOCUMENT AND MAY NOT BE MODIFIED MANUALLY

REV	DATE	DESCRIPTION	BY
A	May-07-25	NEW DRAWING	TAZ

UNLESS OTHERWISE SPECIFIED
 DIMENSIONAL TOLERANCE
 .X ± .1
 .XX ± .01
 .XXX ± .005
 ANGLES ± 30°
 SURFACE FINISH 125
 BREAK ALL EDGES .005/.015
 CORNER RADIUS .010/.030
 ALL ANGLES ARE 90°

QUADREL LABELING SYSTEMS
 7670 JENTHER DRIVE
 MENTOR, OHIO 44060
 (440) 602-4700

SCALE: 5/8
 DATE: May-07-25
 DRW BY: TAZ
 CHK BY:
 APPR BY:

CORNER PANEL TRAILING WIPE, 4"

MAT'L

21712-012

ITEM	QTY	PART NO.	DESCRIPTION	PARENT ITEM
1	1	391201-000	FILTER, AIR	22677-000
2	1	391201-MTG	FILTER / REGULATOR W/GUAGE & BRK	22677-000
3	1	391811-000	DISCONNECT, SLEEVE	22677-000
4	1	391906-000	90 ELBOW	22677-000
5	1	391954-000	FITTING, 1/4 NPT QUICK DISCONNECT	22677-000
6	1	392111-000	3/8" TUBE TO 1/8" THREAD MALE ELBOW	22677-000

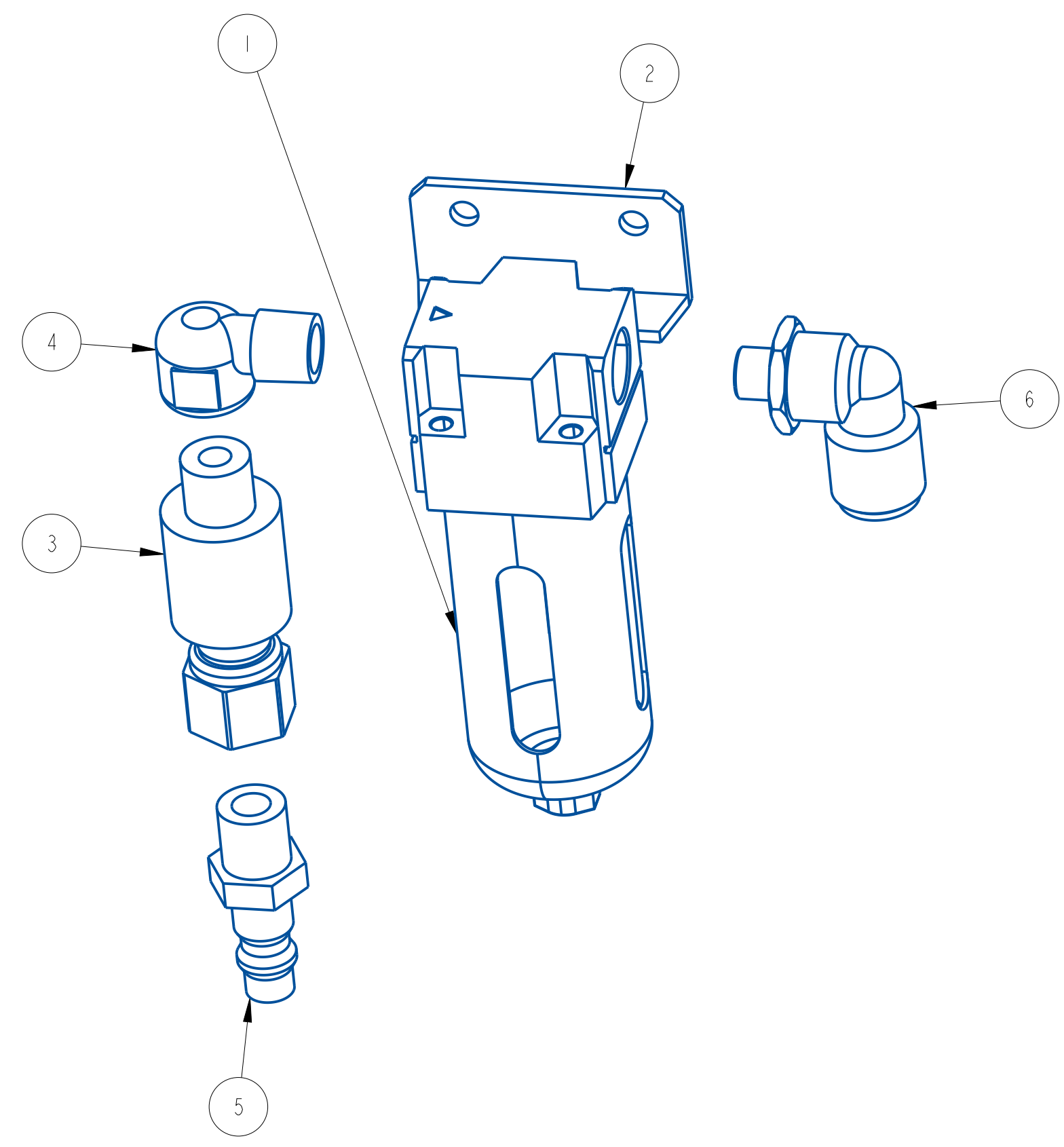

REV	DATE	DESCRIPTION	BY
A	8-17-22	NEW DRAWING	ATT

THIS IS A PRO-ENGINEER DOCUMENT AND MAY NOT BE MODIFIED MANUALLY

UNLESS OTHERWISE SPECIFIED DIMENSIONAL TOLERANCE .X ± .1 .XX ± .01 .XXX ± .005 ANGLES ± 30° SURFACE FINISH 125 BREAK ALL EDGES .005/0.15 CORNER RADIUS .010/0.30	 QUADREL LABELING SYSTEMS 7670 JENTHER DRIVE MENTOR, OHIO 44060 (440) 602-4700	SCALE: 1/1
		DATE: 8-17-22
PNEUMATIC INLET		DRW BY: ATT CHK BY: 03/05/2024-SEM APPR BY:
MAT'L		22677-000

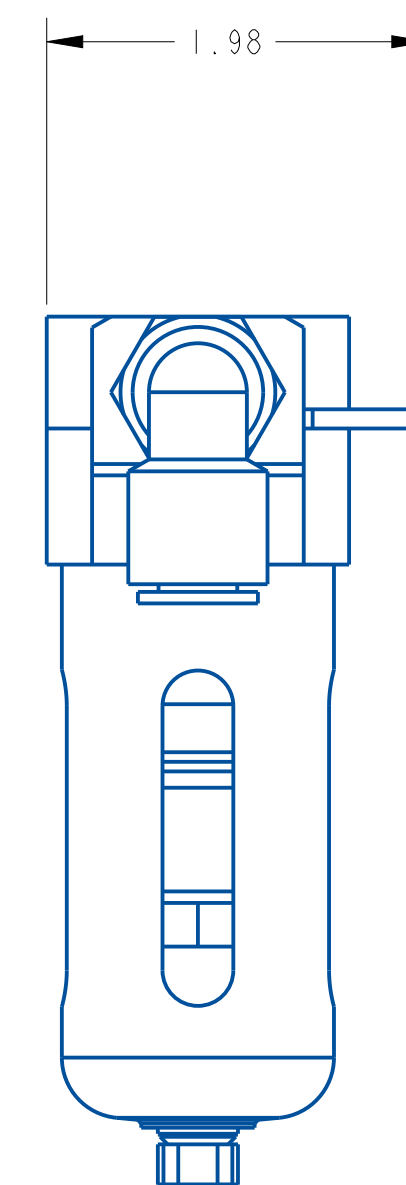
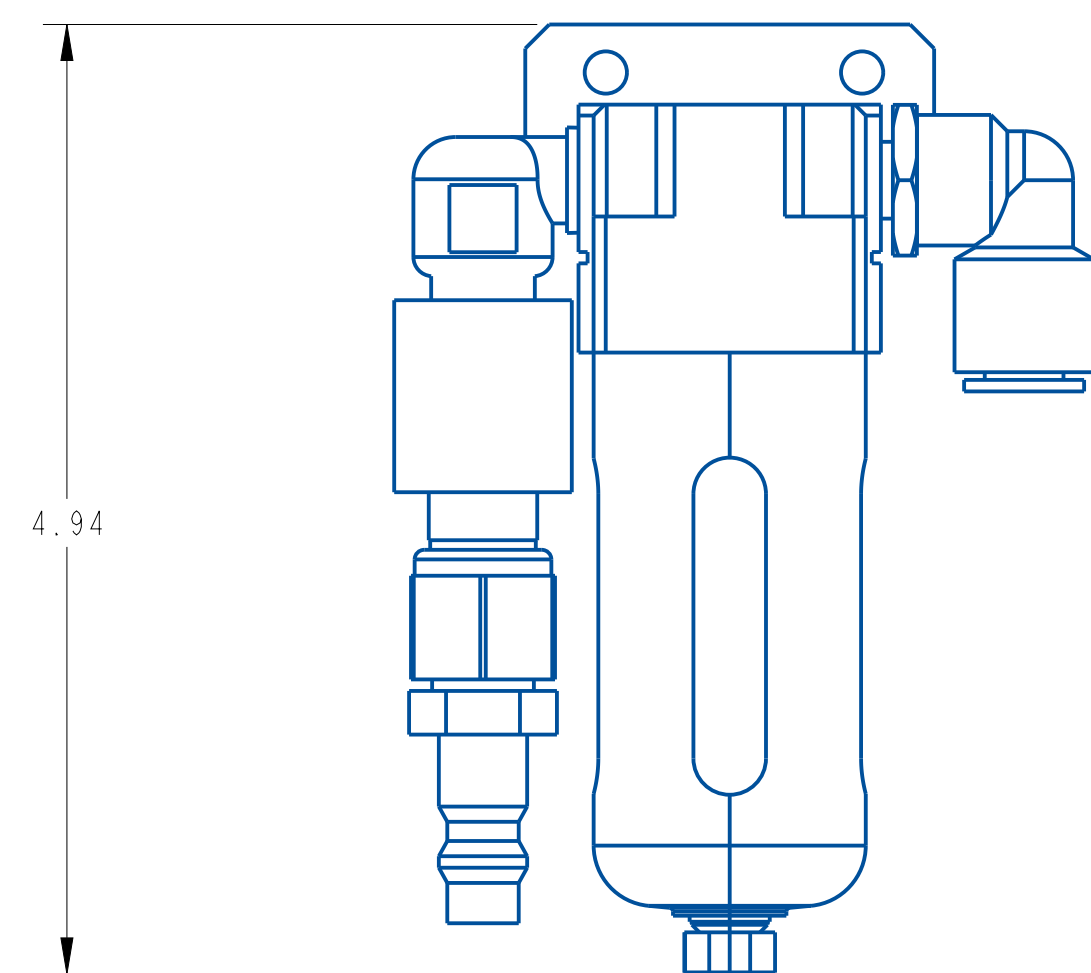
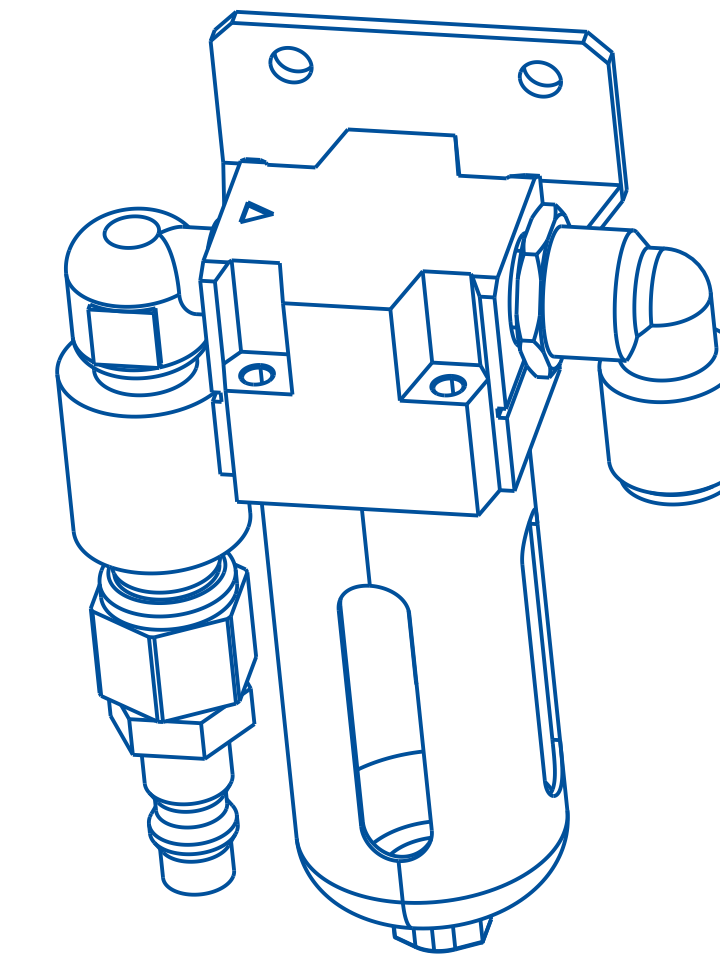
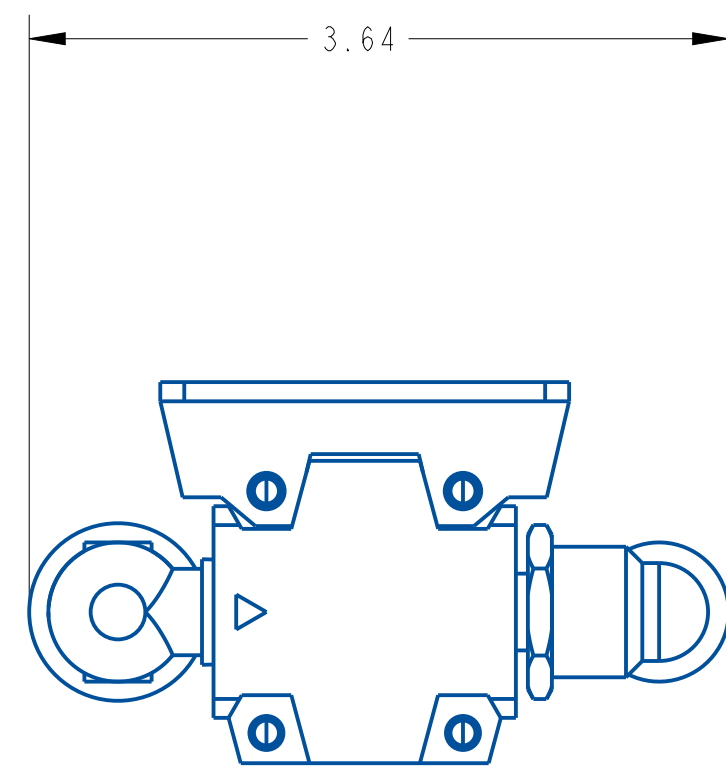

REV	DATE	DESCRIPTION	BY
A	8-17-22	NEW DRAWING	ATT

THIS IS A PRO-ENGINEER DOCUMENT AND MAY NOT BE MODIFIED MANUALLY

UNLESS OTHERWISE SPECIFIED
DIMENSIONAL TOLERANCE
 X ± .1
 XX ± .01
 XXX ± .005
 ANGLES ± .30°
 SURFACE FINISH 125
 BREAK ALL EDGES .005/ .015
 CORNER RADIUS .010/ .030
 ALL ANGLES ARE 90°

QUADREL LABELING SYSTEMS
 7670 JENTHER DRIVE
 MENTOR, OHIO 44060
 (440) 602-4700

SCALE: 1/1
 DATE: 8-17-22
 DRW BY: ATT
 CHK BY: 03/05/2024-SEM
 APPR BY:

PNEUMATIC INLET
 MAT'L

22677-000

ITEM	QTY	PART NO.	DESCRIPTION	PARENT ITEM
1	2	30653-000	CLAMPING ROD ASSEMBLY	84127TT-000
2	2	092043-000	"T" CLAMP, 1/2 BORE	84127TT-000
3	2	362186-000	COLLAR, 3/8 IN. ID ONE-PIECE CLAMP	84127TT-000
4	2	791460-000	CLAMP RAIL, ROUND HOLE	84127TT-000
5	2	792711-000	CAP, ORANGE	84127TT-000
6	4	A20904-005	RAIL SPACER, 1/2"	84127TT-000
7	1	A24323-006	SUPPORT ROD 21"	84127TT-000

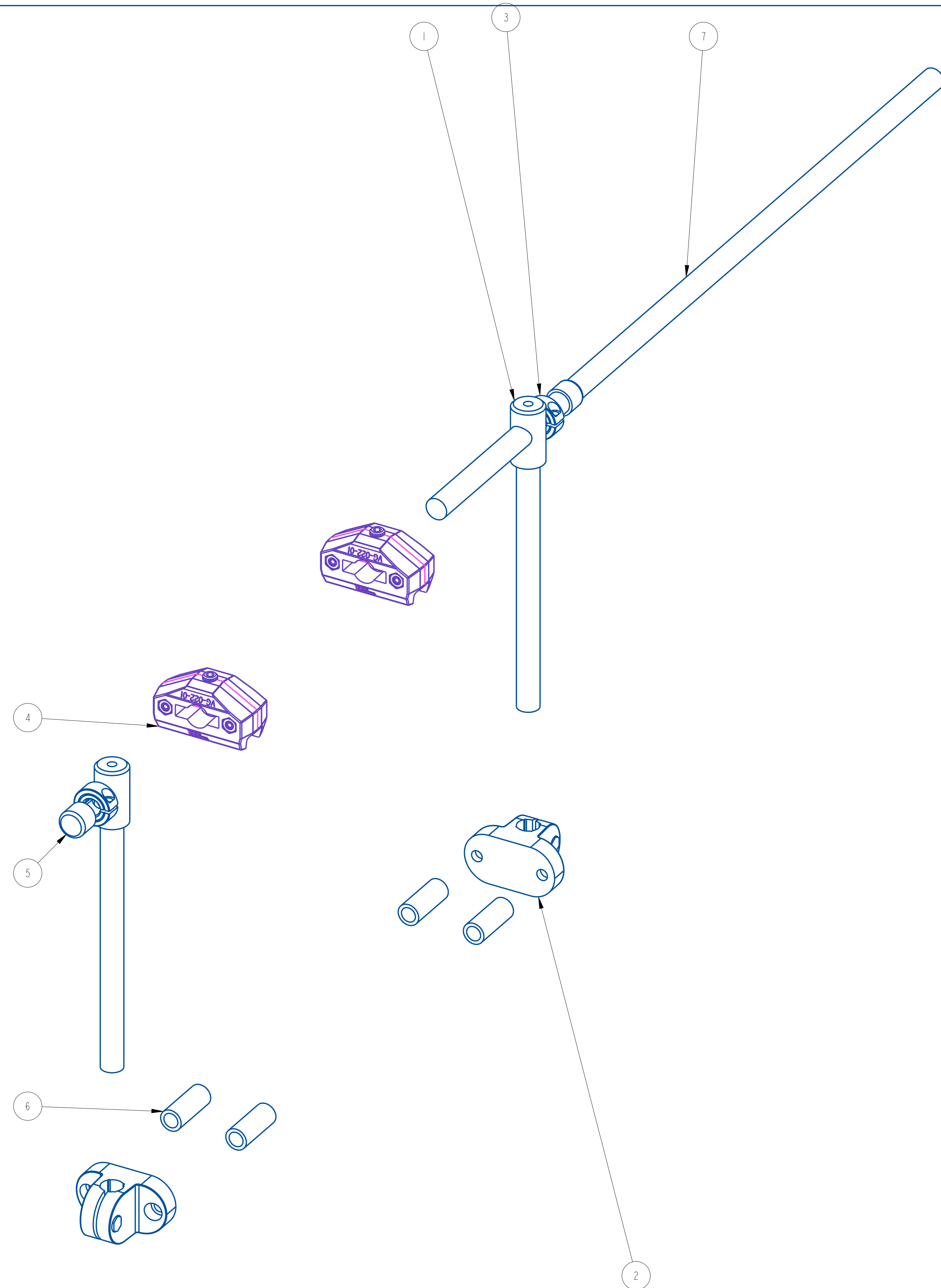

REV	DATE	DESCRIPTION	BY
A	May-07-25	NEW DRAWING	TAZ

THIS IS A PRO-ENGINEER DOCUMENT AND MAY NOT BE MODIFIED MANUALLY

UNLESS OTHERWISE SPECIFIED
 DIMENSIONAL TOLERANCE
 .XX ± .01
 .XXX ± .005
 ANGLES ± 30°
 SURFACE FINISH 125
 BREAK ALL EDGES .005/0.15
 CORNER RADIUS .010/0.30
 ALL ANGLES ARE 90°

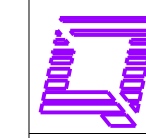

QUADREL LABELING SYSTEMS
 7670 JENTHER DRIVE
 MENTOR, OHIO 44060
 (440) 602-4700

SCALE: 3/4
 DATE: May-07-25
 DRW BY: TAZ
 APPR BY:

RAIL TOP HOLD DOWN

MAT'L 84127TT-000 84127TT-000

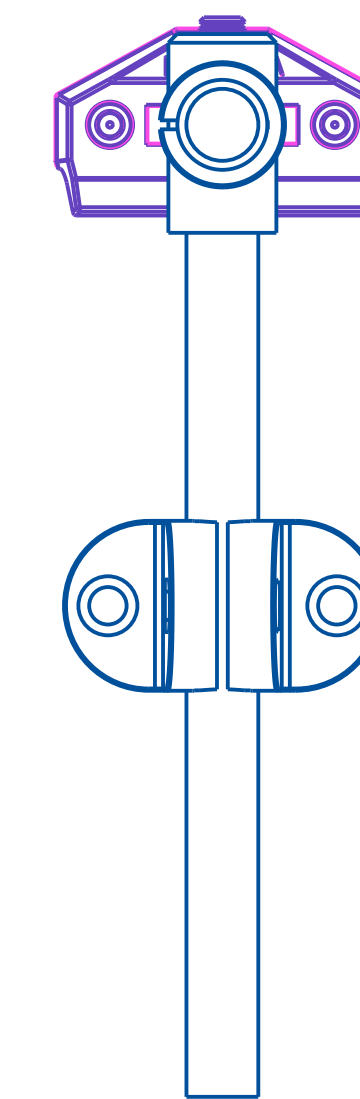
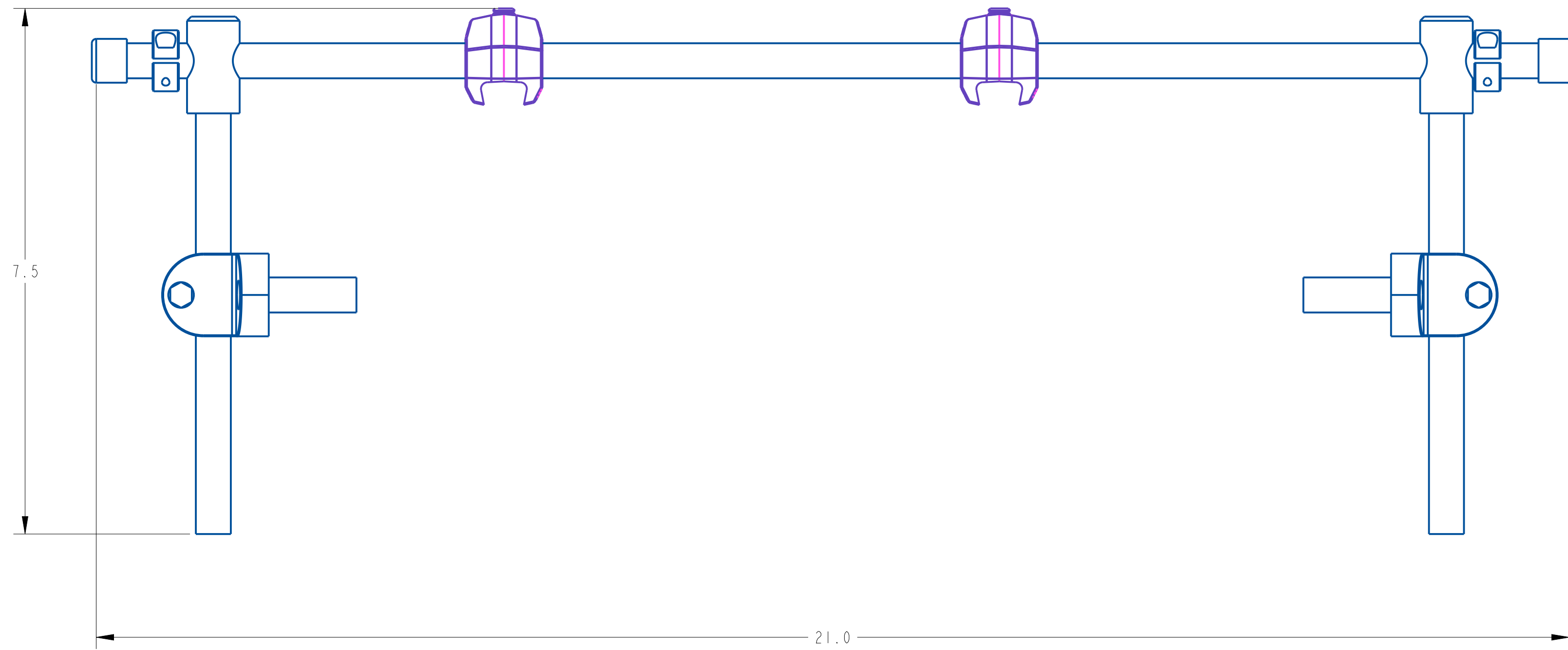
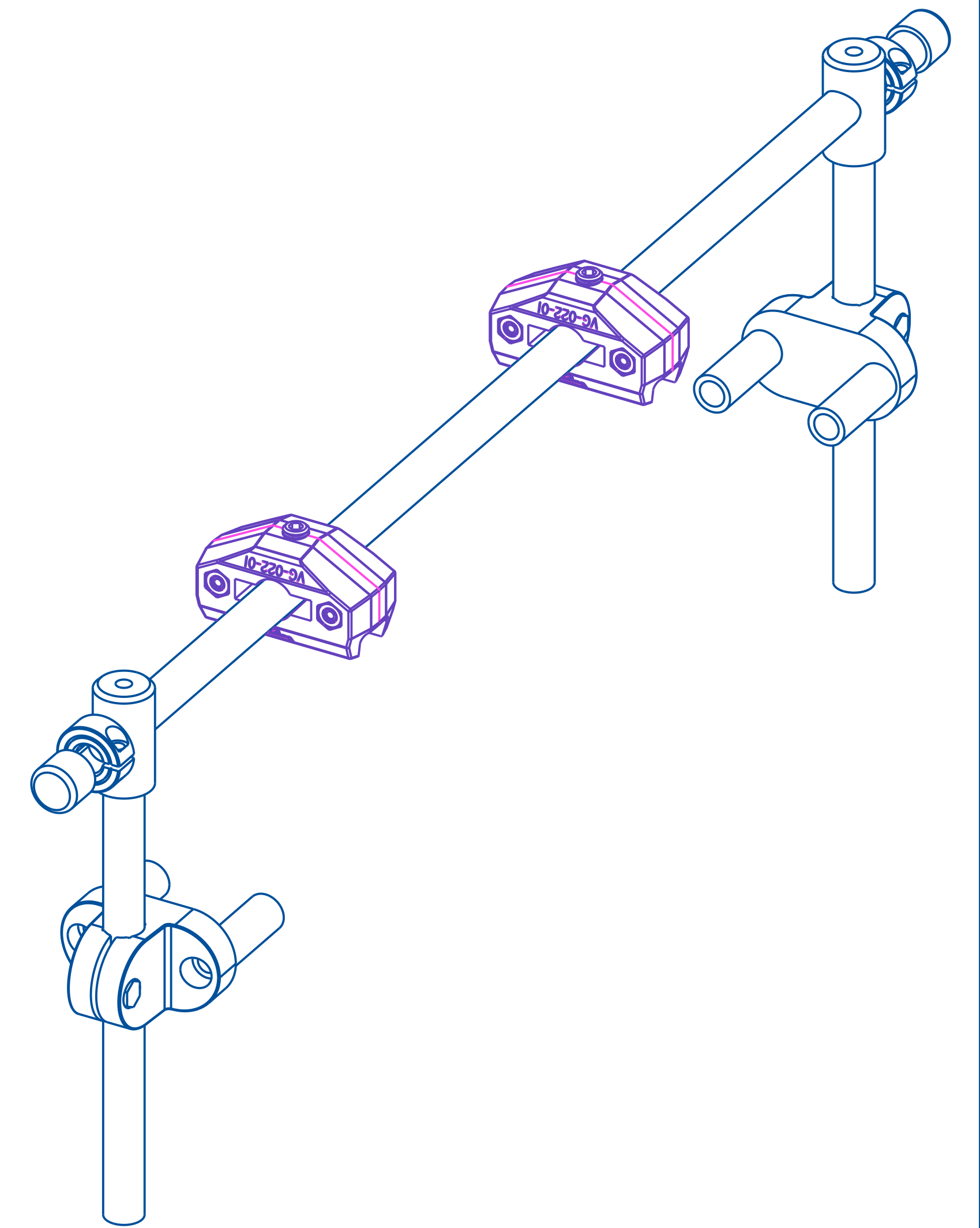

REV	DATE	DESCRIPTION	BY
A	May-07-25	NEW DRAWING	TAZ

THIS IS A PRO-ENGINEER DOCUMENT AND MAY NOT BE MODIFIED MANUALLY

UNLESS OTHERWISE SPECIFIED
DIMENSIONAL TOLERANCE

.x ± .1
 .xx ± .01
 .xxx ± .005
 ANGLES ± .30°

SURFACE FINISH 125
 BREAK ALL EDGES .005/.015
 CORNER RADIUS .010/.030
 ALL ANGLES ARE 90°

QUADREL LABELING SYSTEMS
 7670 JENTHER DRIVE
 MENTOR, OHIO 44060
 (440) 602-4700

SCALE: 3/4
 DATE: May-07-25
 DRW BY: TAZ
 APPR BY:

RAIL TOP HOLD DOWN

MAT'L	84127TT-000	84127TT-000
-------	-------------	-------------

ASSEMBLY TITLE: HUGGER BELT

GENERAL FUNCTION:

- The hugger belt assembly provides positive drive through the labeling station. It is controlled by a variable speed AC motor.

SET-UP AND ADJUSTMENTS:

- To adjust in/out spacing, turn handle at either end of the horizontal screw.

MAINTENANCE:

- Ensure that the hugger belts are free of labels. Remove label material using an environmentally safe adhesive cleaner.
- Inspect the belt weekly for evidence of excessive wear or stretching. Ensure that belt tension is correct to prevent these conditions.

TROUBLESHOOTING:

PROBLEM

WHAT TO DO

Will not hold product

Adjust in/out spacing to apply more pressure to product. See SET UP AND ADJUSTMENTS.



ITEM	QTY	PART NO.	DESCRIPTION	PARENT ITEM
1	1	181079-000	BEARING, NEEDLE ROLLER	84263HBM-000
2	2	181080-000	BEARING, THRUST WASHER	84263HBM-000
3	2	792248-000	PILLOW BLOCK	84263HBM-000
4	1	792354-000	DIGITAL POSITION INDICATOR	84263HBM-000
5	1	801332-000	LOBE KNOB W/ ORANGE CENTER	84263HBM-000
6	1	A25507-008	ADJUSTMENT BLOCK	84263HBM-000
7	1	A28464-000	HUGGER MOUNTING BLOCK	84263HBM-000
8	1	A28464-002	HUGGER MOUNTING BLOCK	84263HBM-000
9	1	B22005-012	BEARING PLATE	84263HBM-000
10	2	B22104-024	MOUNTING ANGLE	84263HBM-000
11	2	B22381-007	DRYLIN RAIL	84263HBM-000
12	2	B22874-000	MOUNTING PLATE	84263HBM-000
13	1	C20977-665	THREADED ROD, RH	84263HBM-000

NOT SHOWN:
A28464-001 HUGGER MOUNTING BLOCK

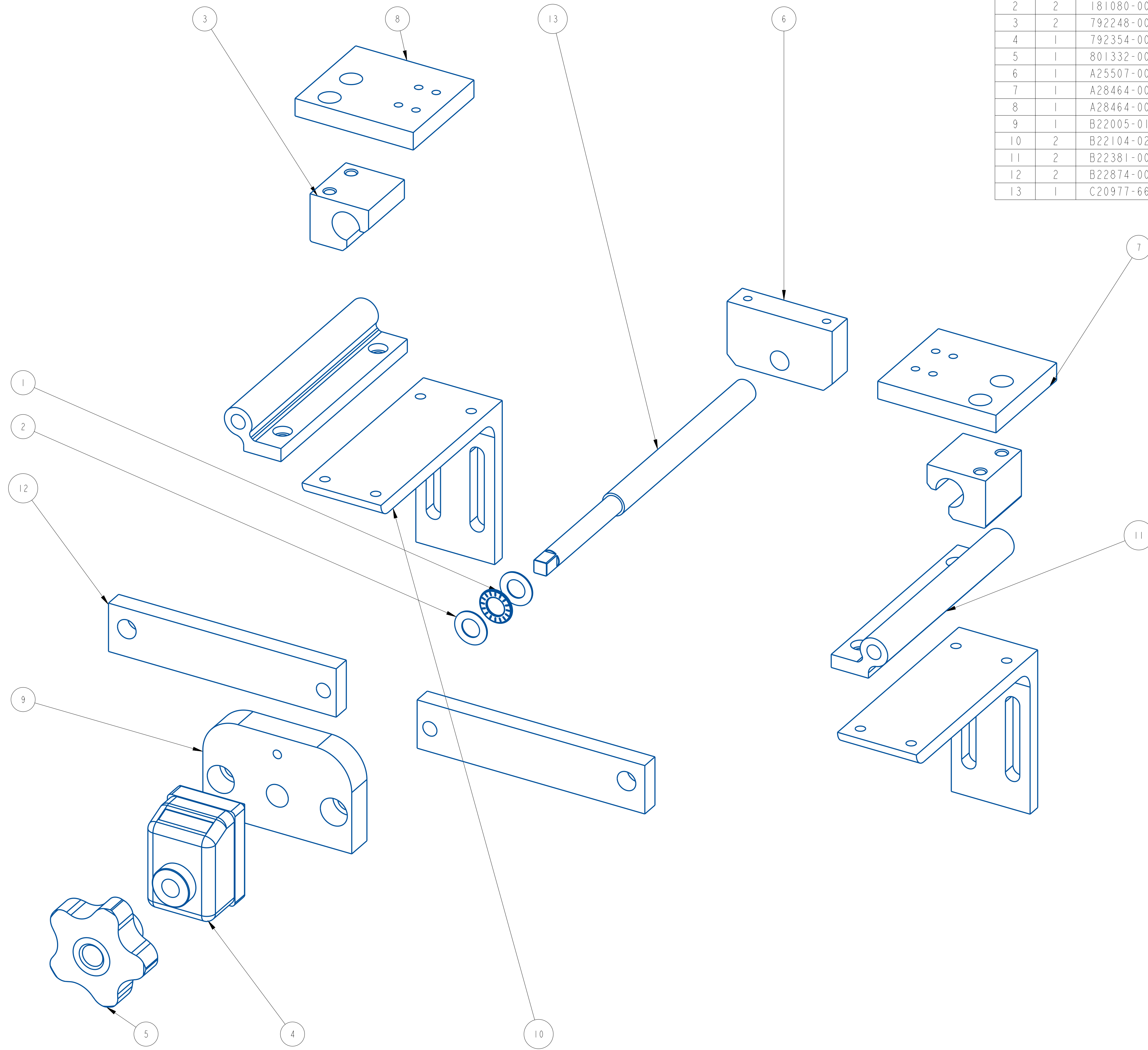

REV	DATE	DESCRIPTION	BY
A	Jan-13-26	NEW DRAWING	TAZ

THIS IS A PRO-ENGINEER DOCUMENT AND MAY NOT BE MODIFIED MANUALLY

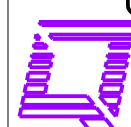
<small>UNLESS OTHERWISE SPECIFIED DIMENSIONAL TOLERANCE</small> xx ± .01 xxx ± .005 ANGLES ± .30° SURFACE FINISH 125 BREAK ALL EDGES .005/ .015 CORNER RADIUS .010/ .030 ALL ANGLES ARE 90°	 QUADREL LABELING SYSTEMS 7670 JENTHER DRIVE MENTOR, OHIO 44060 (440) 602-4700	SCALE: 3/4
		DATE: Jan-13-26
		DRW BY: TAZ
		CHK BY:
HUGGER BELT MOUNT		MATERIAL: 84263HBM-000
		PART NO.: 84263HBM-000

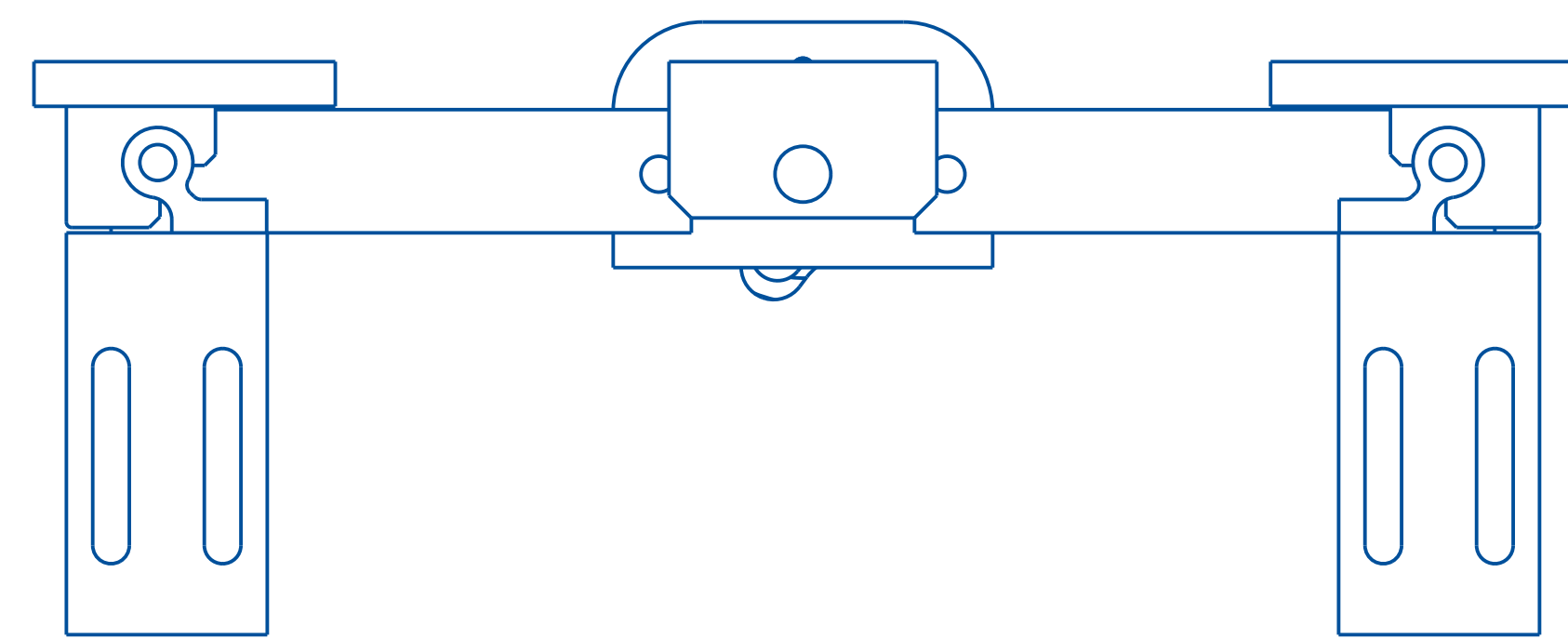
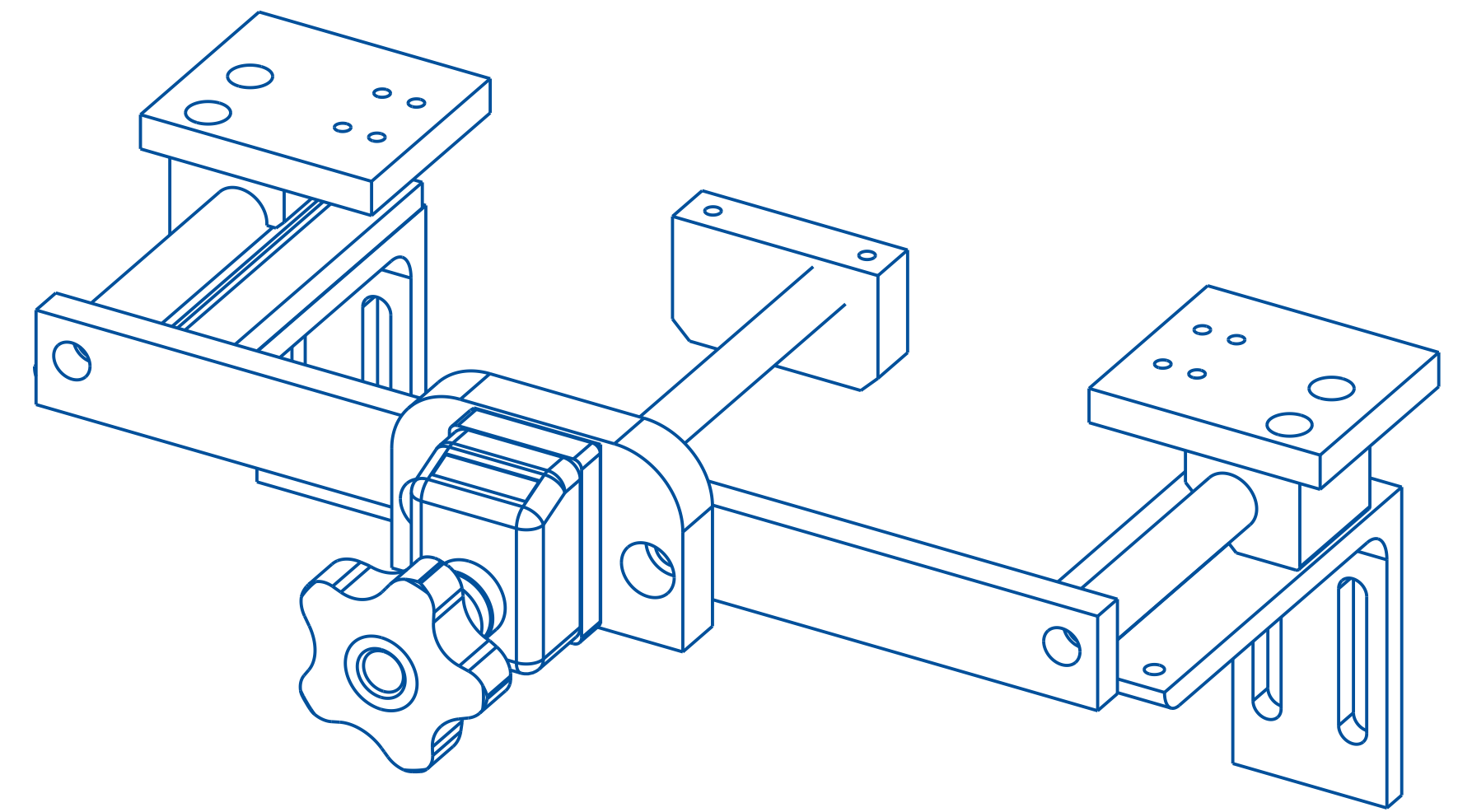
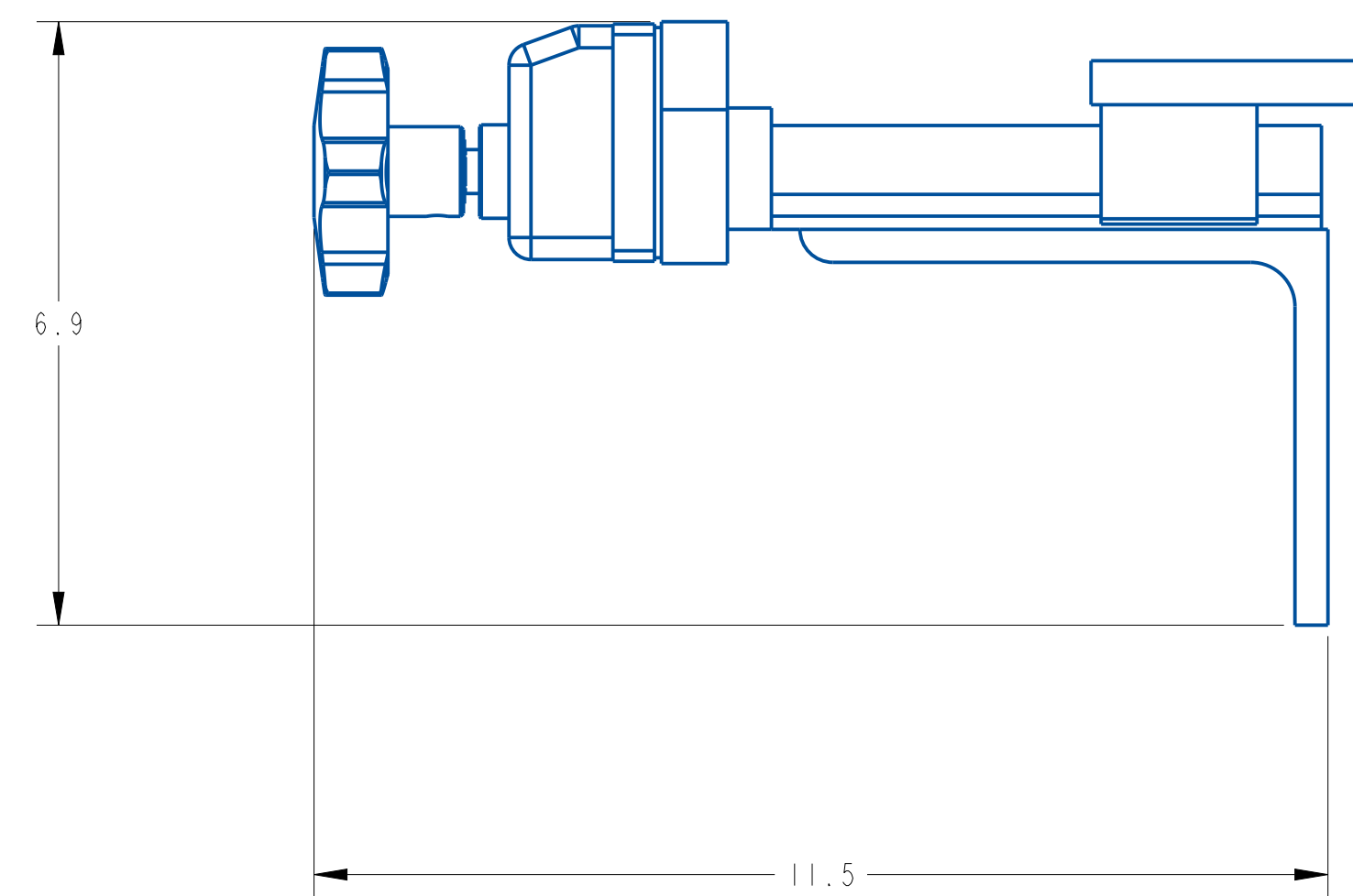
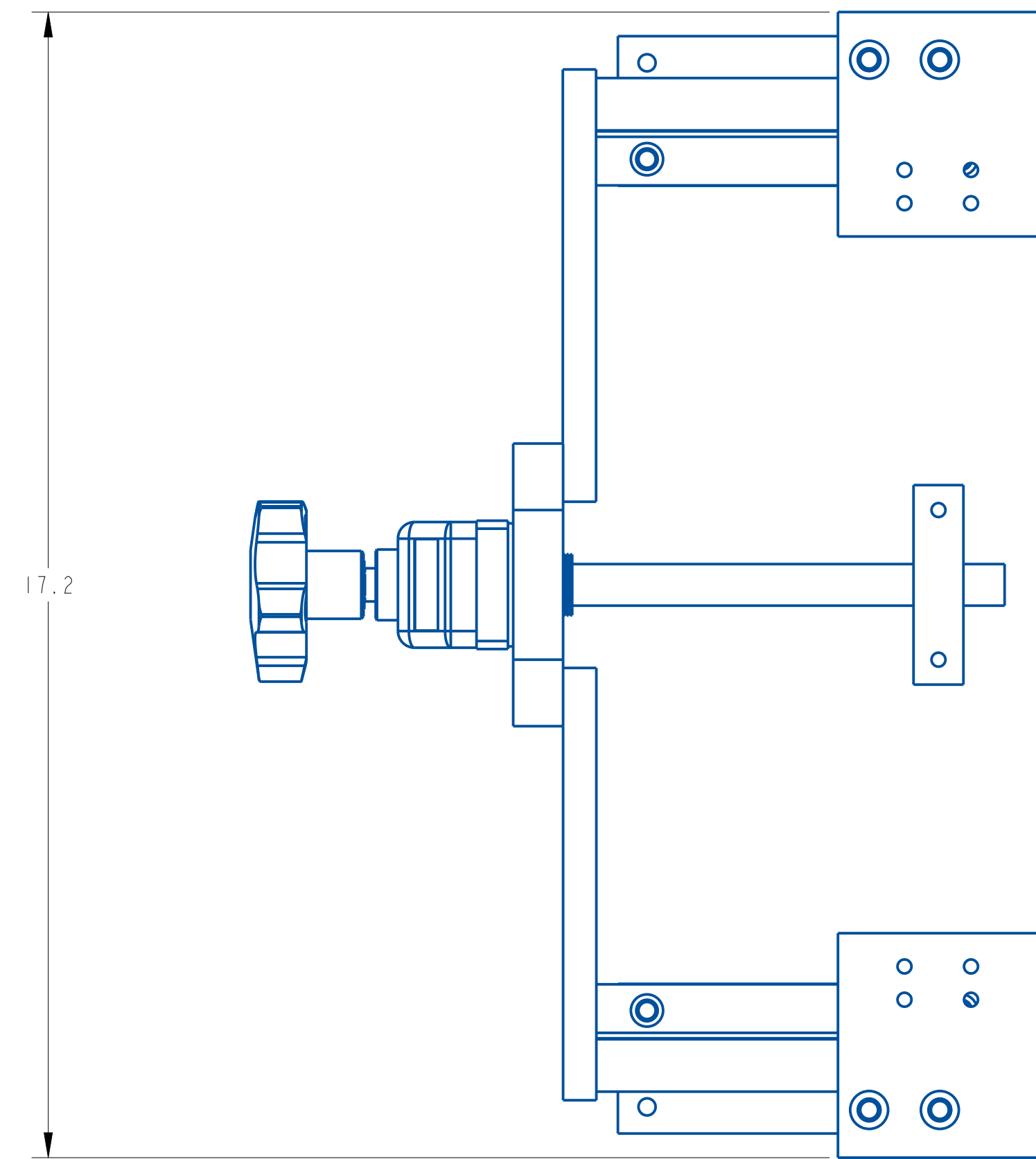

A		Jan-13-26	NEW DRAWING	TAZ
REV	DATE	DESCRIPTION	BY	
<p>THIS IS A PRO-ENGINEER DOCUMENT AND MAY NOT BE MODIFIED MANUALLY</p> <p>UNLESS OTHERWISE SPECIFIED DIMENSIONAL TOLERANCE</p> <p>X ± .1 XX ± .01 XXX ± .005 ANGLES ± .30°</p> <p>SURFACE FINISH 125 BREAK ALL EDGES .005/ .015 CORNER RADIUS .010/ .030 ALL ANGLES ARE 90°</p>				
<p>QUADREL LABELING SYSTEMS 7670 JENTHER DRIVE MENTOR, OHIO 44060 (440) 602-4700</p>			<p>SCALE: 1/2 DATE: Jan-13-26 DRW BY: TAZ CHK BY: APPR BY:</p>	
<p>HUGGER BELT MOUNT</p>			<p>MAT 'L 84263HBM-000 84263HBM-000</p>	

ITEM	QTY	PART NO.	DESCRIPTION	PARENT ITEM
1	2	111075-000	BEARING, BALL	84127HBR-002
2	2	151008-000	BEARING, THRUST WASHER	84127HBR-002
3	1	393517-000	CYLINDER, 1" STROKE	84127HBR-002
4	1	413016-000	GEARMOTOR-3/8HP-57 RPM 3PHASE	84127HBR-002
5	1	A21824-200	CROWNED IDLER PULLEY	84127HBR-002
6	1	A21826-017	DRIVE PULLEY	84127HBR-002
7	2	A23403-000	FLANGE	84127HBR-002
8	1	A25210-000	ADJUSTMENT MOUNTING	84127HBR-002
9	1	A25211-000	PULLEY GUARD	84127HBR-002
10	1	A25212-125	IDLER SHAFT	84127HBR-002
11	1	A28646-000	PRODUCT ALIGNMENT BLOCK	84127HBR-002
12	1	B22013-016	CUSTOM BELT	84127HBR-002
13	2	B22073-030	WEAR STRIP MOUNTING PLATE	84127HBR-002
14	2	B22075-042	BELT WEAR STRIP	84127HBR-002
15	1	C21005-000	HUGGER BELT TOP RE-ENFORCEMENT PLATE	84127HBR-002
16	1	C21006-001	MOTOR MOUNTING PLATE	84127HBR-002
17	1	D22218-030R	BOTTOM HUGGER BELT PLATE	84127HBR-002
18	1	D22219-042R	TOP HUGGER BELT PLATE	84127HBR-002
19	1	HCS039		84127HBR-002
20	1	HMSN26		84127HBR-002

NOT SHOWN:
 B23278-000 IMPRESSOR ROLLER MOUNT
 092610-000 SKATE WHEEL (IMPRESSOR)

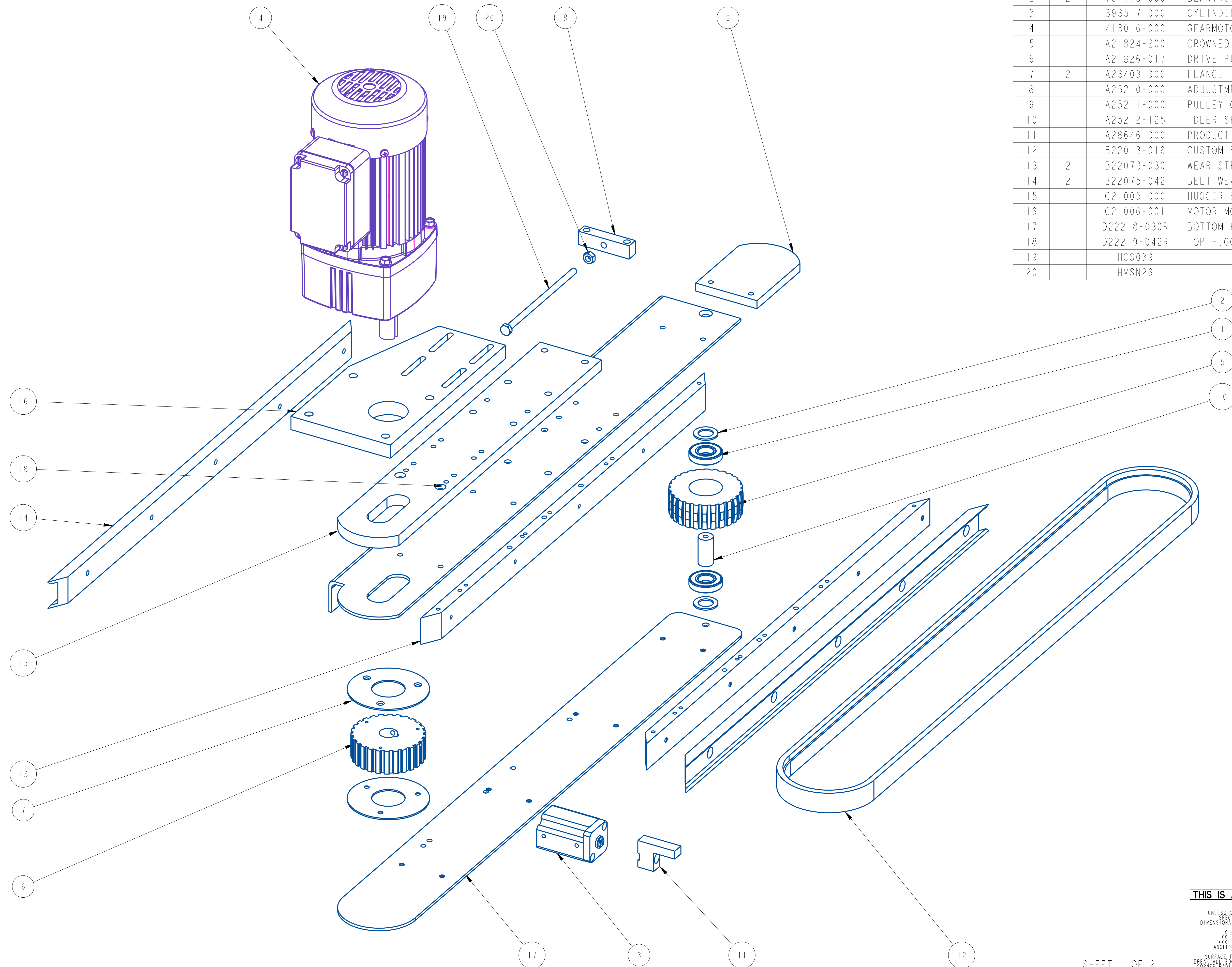

REV	DATE	DESCRIPTION	BY
A	Jan-14-26	NEW DRAWING	TAZ

THIS IS A PRO-ENGINEER DOCUMENT AND MAY NOT BE MODIFIED MANUALLY

UNLESS OTHERWISE SPECIFIED
 DIMENSIONAL TOLERANCE
 X ± .1
 XX ± .01
 XXX ± .005
 ANGLES ± .30°

SURFACE FINISH 125
 BREAK ALL EDGES .005/.015
 CORNER RADIUS .010/.030
 ALL ANGLES ARE 90°

QUADREL LABELING SYSTEMS
 7670 JENTHER DRIVE
 MENTOR, OHIO 44060
 (440) 602-4700

SCALE: 1/2
 DATE: Jan-14-26
 DRW BY: TAZ
 CHK BY: 01/16/2026-SEM
 APPR BY:

HUGGER BELT RIGHT

MAT'L 84127HBR-002 84127HBR-002

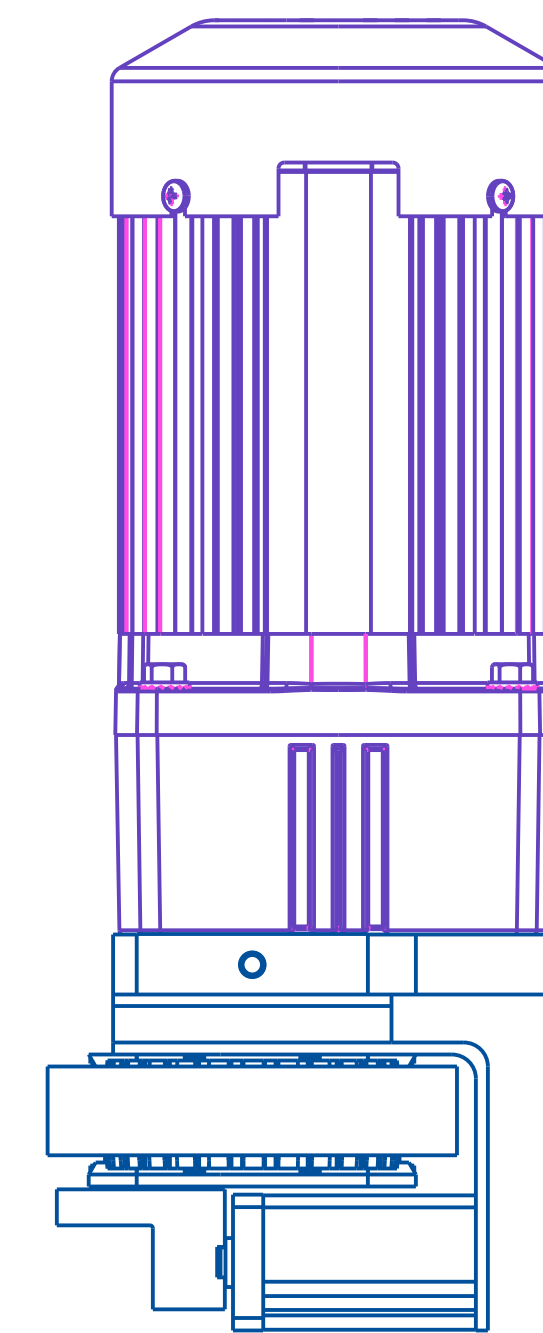
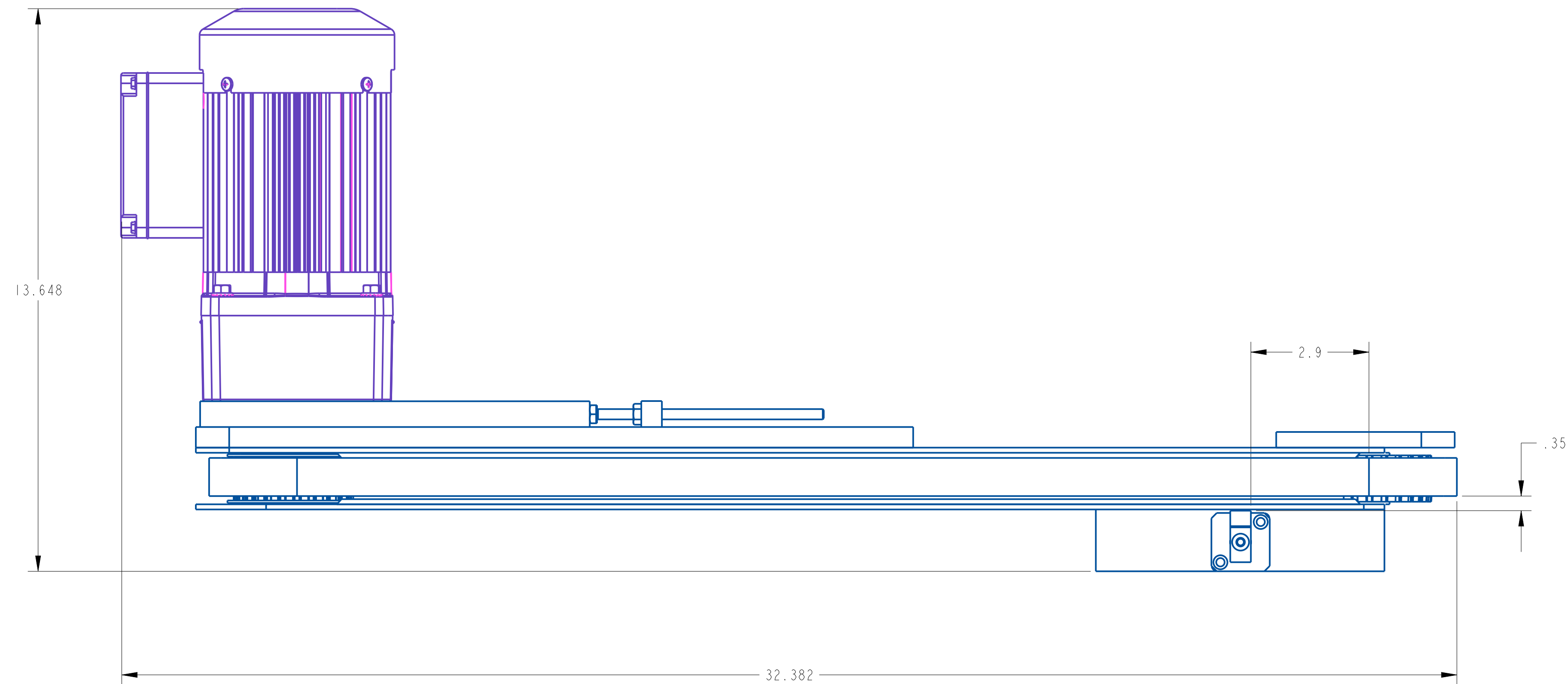
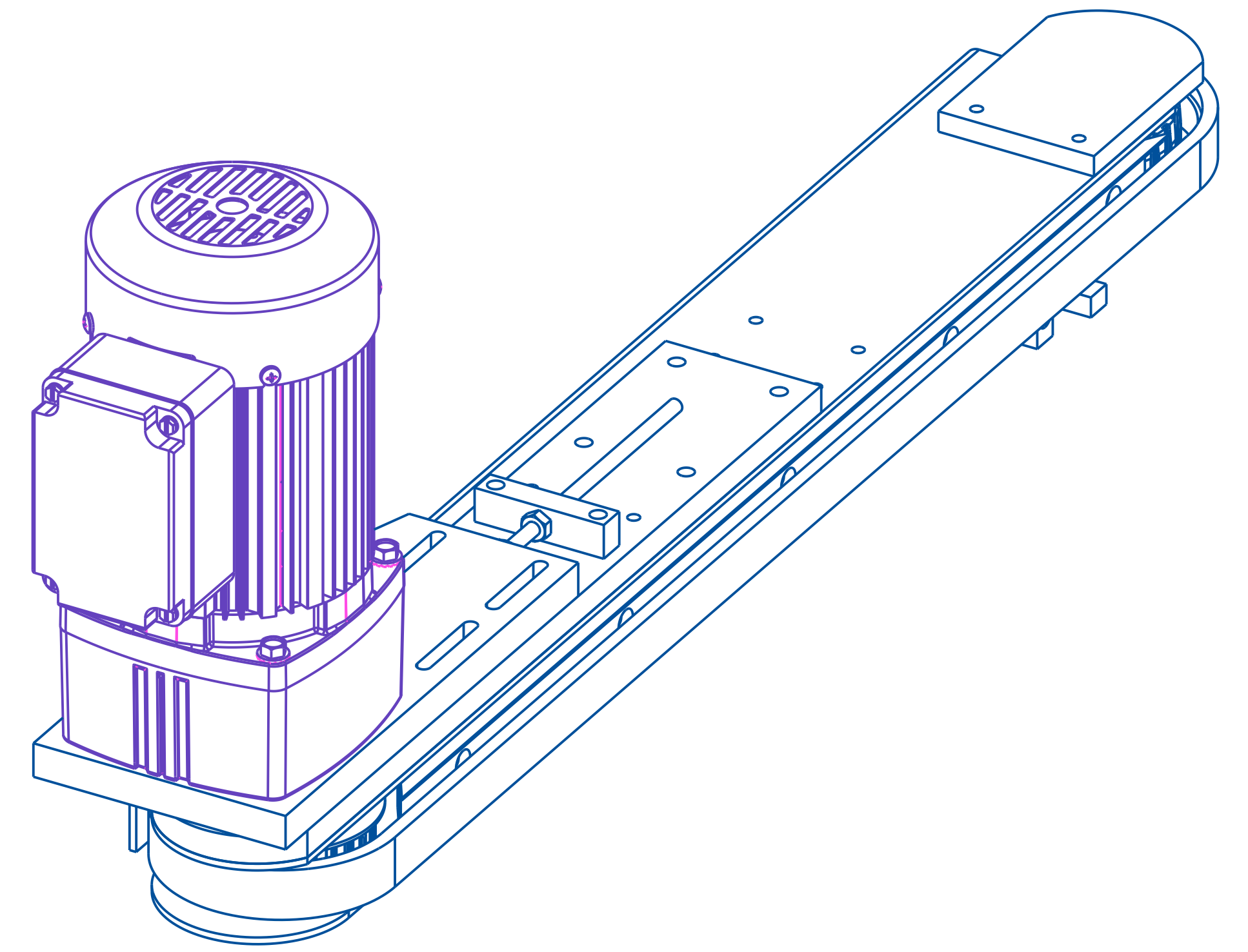
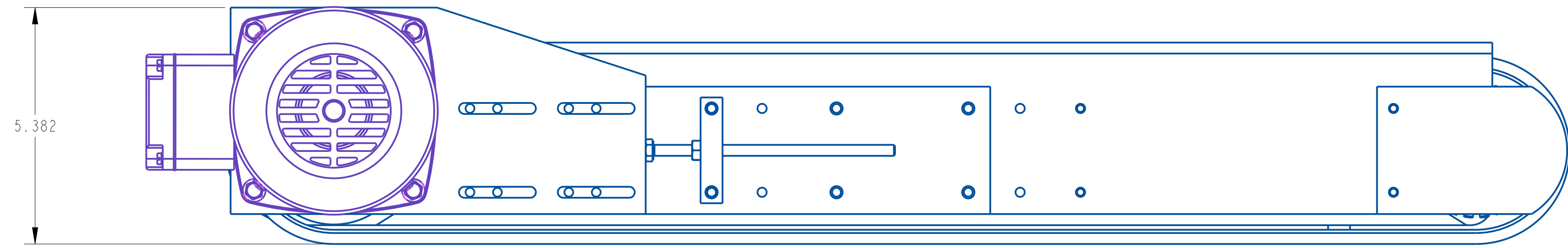

REV	DATE	DESCRIPTION	BY
A	Jan-14-26	NEW DRAWING	TAZ

THIS IS A PRO-ENGINEER DOCUMENT AND MAY NOT BE MODIFIED MANUALLY

UNLESS OTHERWISE SPECIFIED
DIMENSIONAL TOLERANCE
X ± .1
XX ± .01
XXX ± .005
ANGLES ± .30°
SURFACE FINISH 125
BREAK ALL EDGES .005/.015
CORNER RADIUS .010/.030
ALL ANGLES ARE 90°

QUADREL LABELING SYSTEMS
7670 JENTHER DRIVE
MENTOR, OHIO 44060
(440) 602-4700

SCALE: 1/2
DATE: Jan-14-26
DRW BY: TAZ
CHK BY: 01/16/2026-SEM
APPR BY:

HUGGER BELT RIGHT
MAT'L 84127HBR-002 84127HBR-002

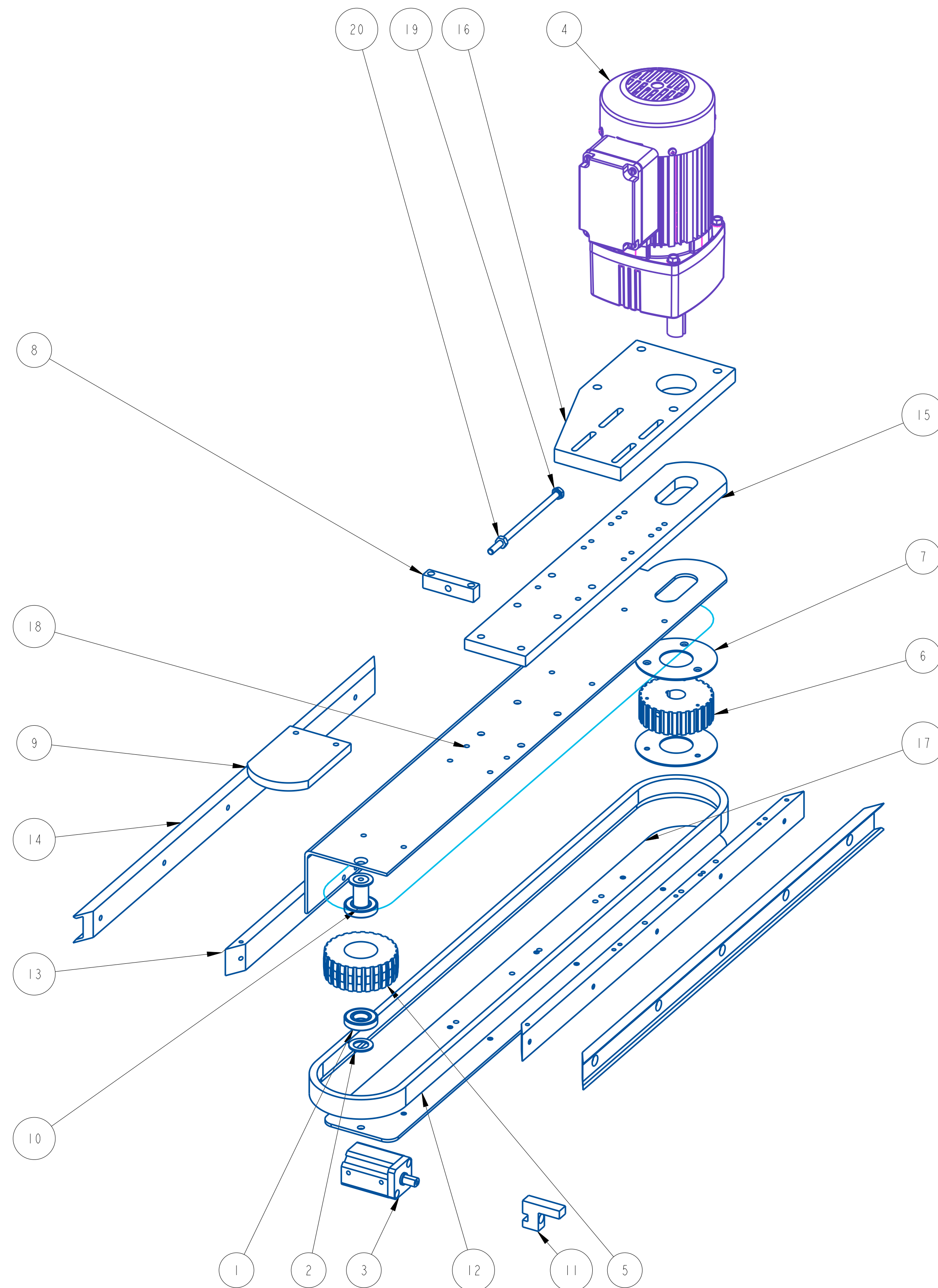

ITEM	QTY	PART NO.	DESCRIPTION	PARENT ITEM
1	2	111075-000	BEARING, BALL	84127HBL-002
2	2	151008-000	BEARING, THRUST WASHER	84127HBL-002
3	1	393517-000	CYLINDER, 1" STROKE	84127HBL-002
4	1	413016-000	GEARMOTOR-3/8HP-57 RPM 3PHASE	84127HBL-002
5	1	A21824-200	CROWNED IDLER PULLEY	84127HBL-002
6	1	A21826-017	DRIVE PULLEY	84127HBL-002
7	2	A23403-000	FLANGE	84127HBL-002
8	1	A25210-000	ADJUSTMENT MOUNTING	84127HBL-002
9	1	A25211-000	PULLEY GUARD	84127HBL-002
10	1	A25212-125	IDLER SHAFT	84127HBL-002
11	1	A28646-000	PRODUCT ALIGNMENT BLOCK	84127HBL-002
12	1	B22013-016	CUSTOM BELT	84127HBL-002
13	2	B22073-030	WEAR STRIP MOUNTING PLATE	84127HBL-002
14	2	B22075-042	BELT WEAR STRIP	84127HBL-002
15	1	C21005-000	HUGGER BELT TOP RE-ENFORCEMENT PLATE	84127HBL-002
16	1	C21006-000	MOTOR MOUNTING PLATE	84127HBL-002
17	1	D22218-030	BOTTOM HUGGER BELT PLATE	84127HBL-002
18	1	D22219-042	TOP HUGGER BELT PLATE	84127HBL-002
19	1	HCS039		84127HBL-002
20	1	HMSN26		84127HBL-002

REV	DATE	DESCRIPTION	BY
A	Jan-13-26	NEW DRAWING	TAZ

THIS IS A PRO-ENGINEER DOCUMENT AND MAY NOT BE MODIFIED MANUALLY

UNLESS OTHERWISE SPECIFIED DIMENSIONAL TOLERANCE .XX ± .01 .XXX ± .005 ANGLES ± 30° SURFACE FINISH 125 BREAK ALL EDGES .005/0.15 CORNER RADIUS .010/0.30	7670 JENTHER DRIVE MENTOR, OHIO 44060 (440) 602-4700	SCALE: 5/16
		DATE: Jan-13-26
		DRW BY: TAZ
		CHK BY: TAZ
HUGGER BELT		APPR BY:
MAT'L	84127HBL-002	84127HBL-002

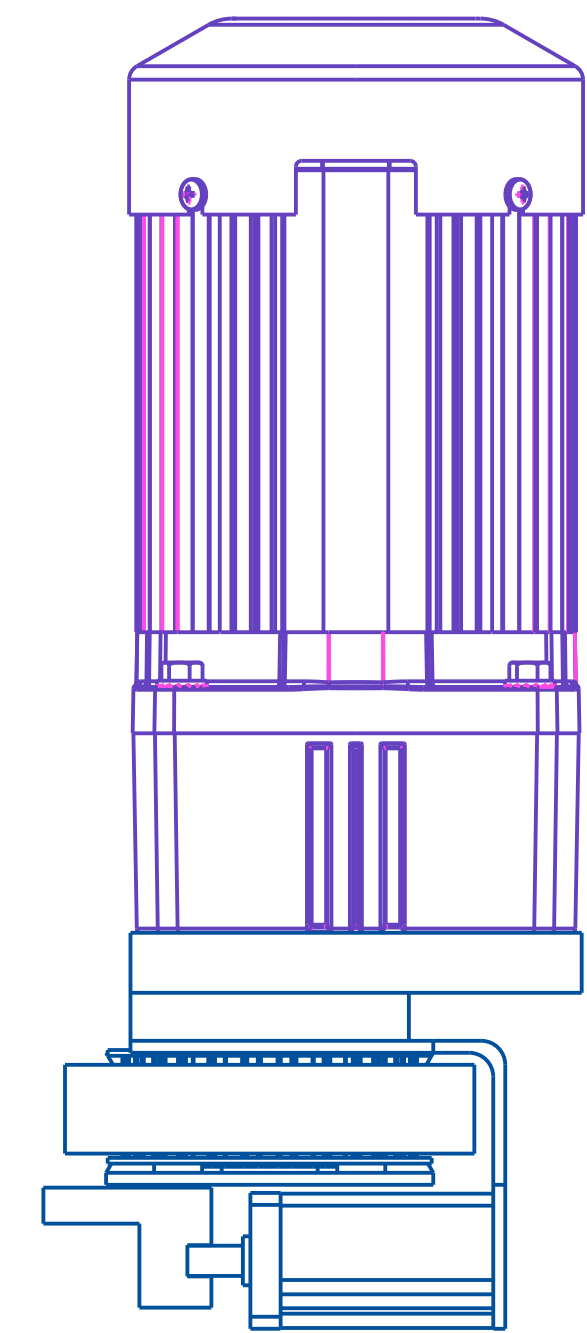
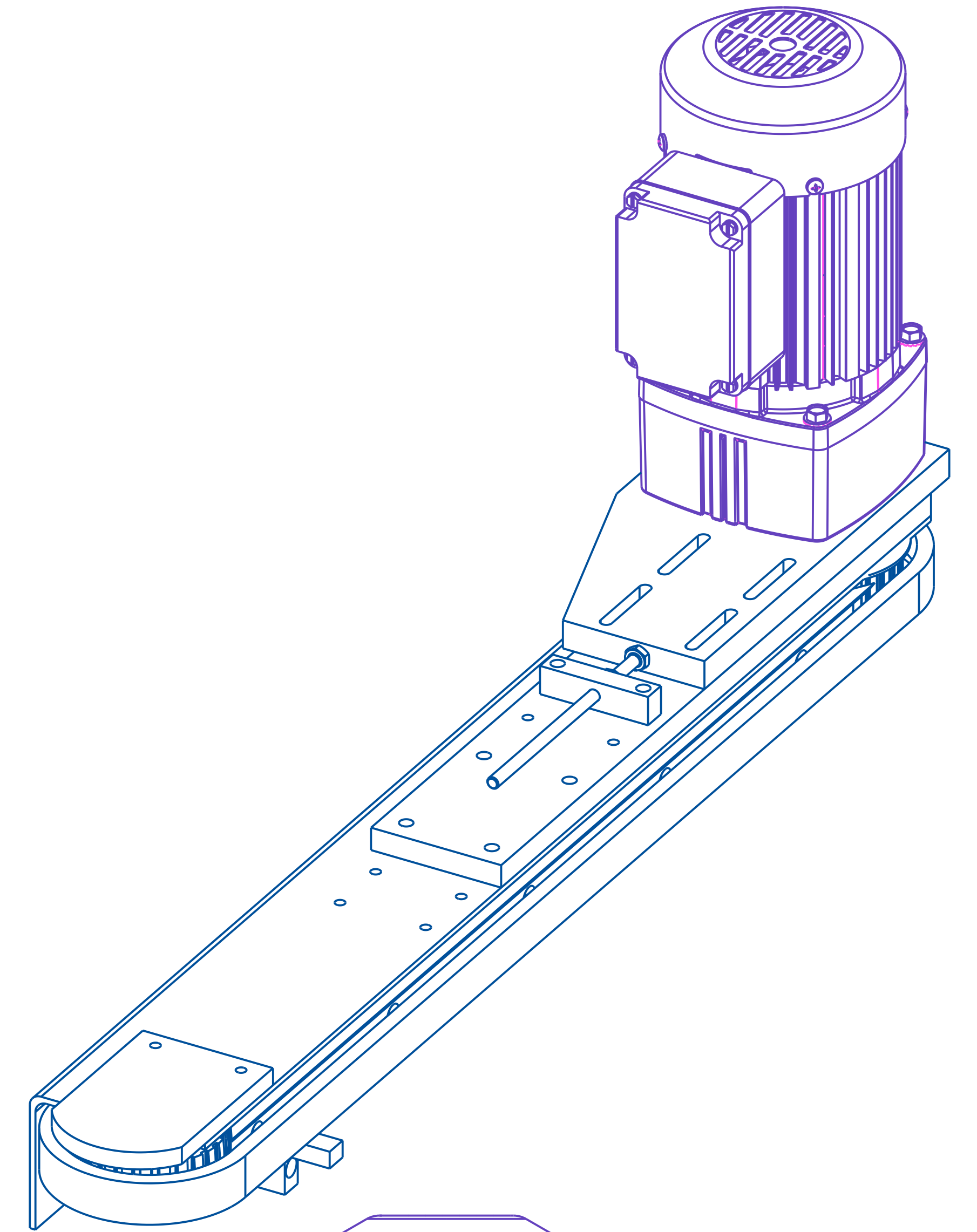
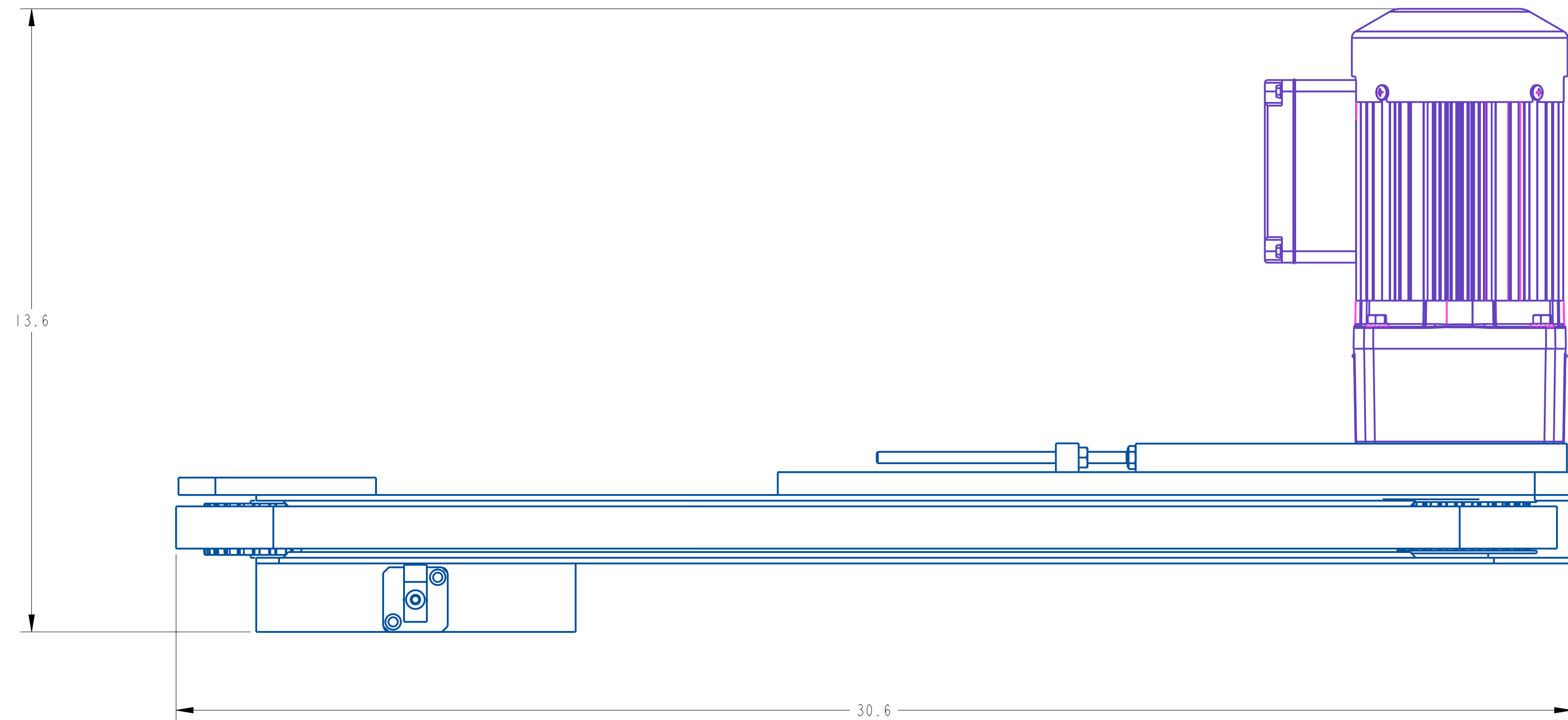
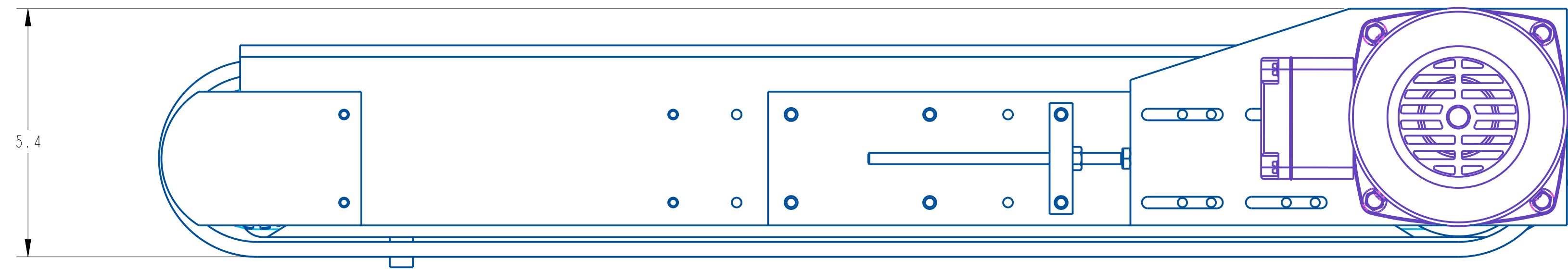

REV	DATE	DESCRIPTION	BY
A	Jan-13-26	NEW DRAWING	TAZ

THIS IS A PRO-ENGINEER DOCUMENT AND MAY NOT BE MODIFIED MANUALLY

UNLESS OTHERWISE SPECIFIED
DIMENSIONAL TOLERANCE
X ± .1
XX ± .01
XXX ± .005
ANGLES ± .30°
SURFACE FINISH 125
BREAK ALL EDGES .005/.015
CORNER RADIUS .010/.030
ALL ANGLES ARE 90°

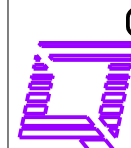

QUADREL LABELING SYSTEMS
7670 JENTHER DRIVE
MENTOR, OHIO 44060
(440) 602-4700

SCALE:	DATE:	CHK BY:	APPR BY:
1/2	Jan-13-26	TAZ	
HUGGER BELT			
MAT'L	84127HBL-002	84127HBL-002	

Electronics

ITEM	QTY	PART NO.	DESCRIPTION	PARENT ITEM
1	1	221152-005	ENCLOSURE, E-STOP W/ BUTTON	20789-000
2	1	241780-000	STRAIN RELIEF, CABLE	20789-000
3	1	241780-001	STRAIN RELIEF, CABLE PANEL	20789-000
4	1	A25719-000	CYLINDER MOUNTING ANGLE	20789-000

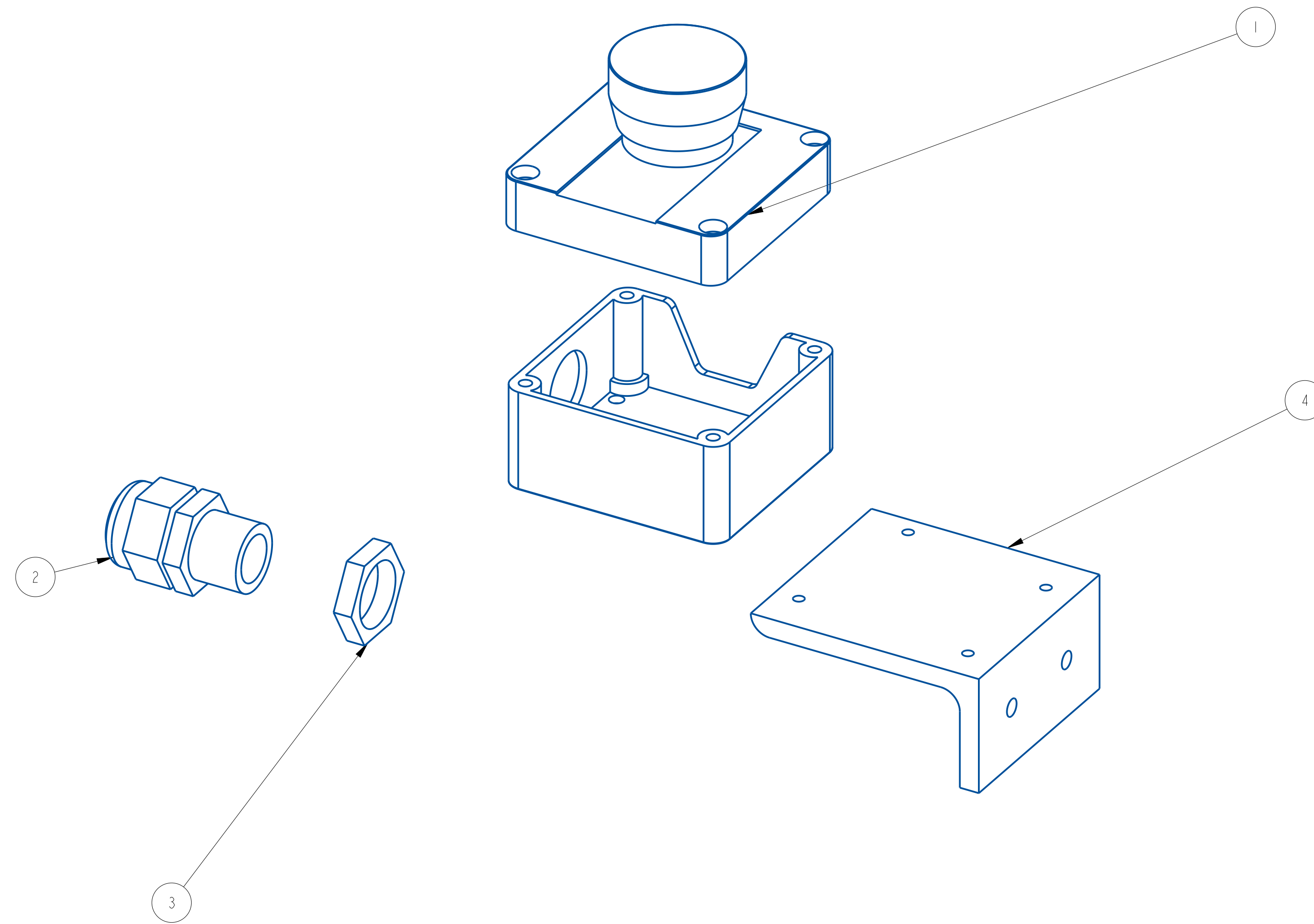

REV	DATE	DESCRIPTION	BY
A	8-29-16	NEW DRAWING	TJS

THIS IS A PRO-ENGINEER DOCUMENT AND MAY NOT BE MODIFIED MANUALLY

UNLESS OTHERWISE SPECIFIED DIMENSIONAL TOLERANCE X ± .1 XX ± .01 XXX ± .005 ANGLES ± 30° SURFACE FINISH 125 BREAK ALL EDGES .005/0.15 CORNER RADIUS .010/0.30	 QUADREL LABELING SYSTEMS 7670 JENTHER DRIVE MENTOR, OHIO 44060 (440) 602-4700	SCALE: 1/1
		DATE: 8-29-16
EMERGENCY STOP ASSEMBLY		DRW BY: TJS
MAT'L		CHK BY: 03/08/2024-SEM
		APPR BY:
		20789-000

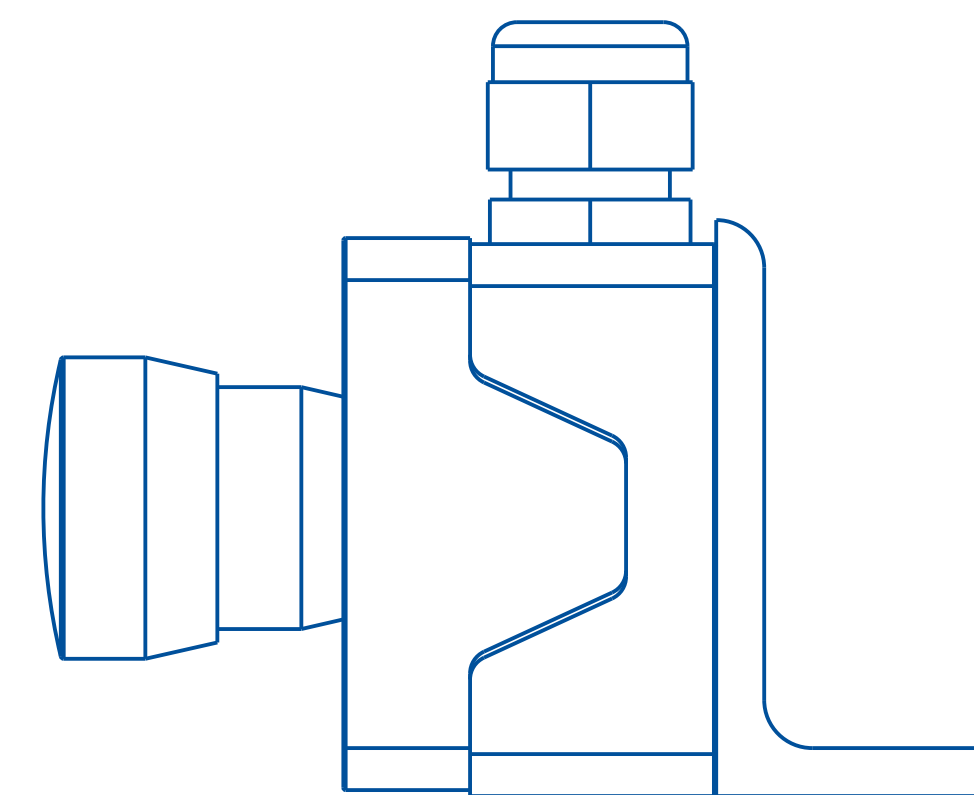
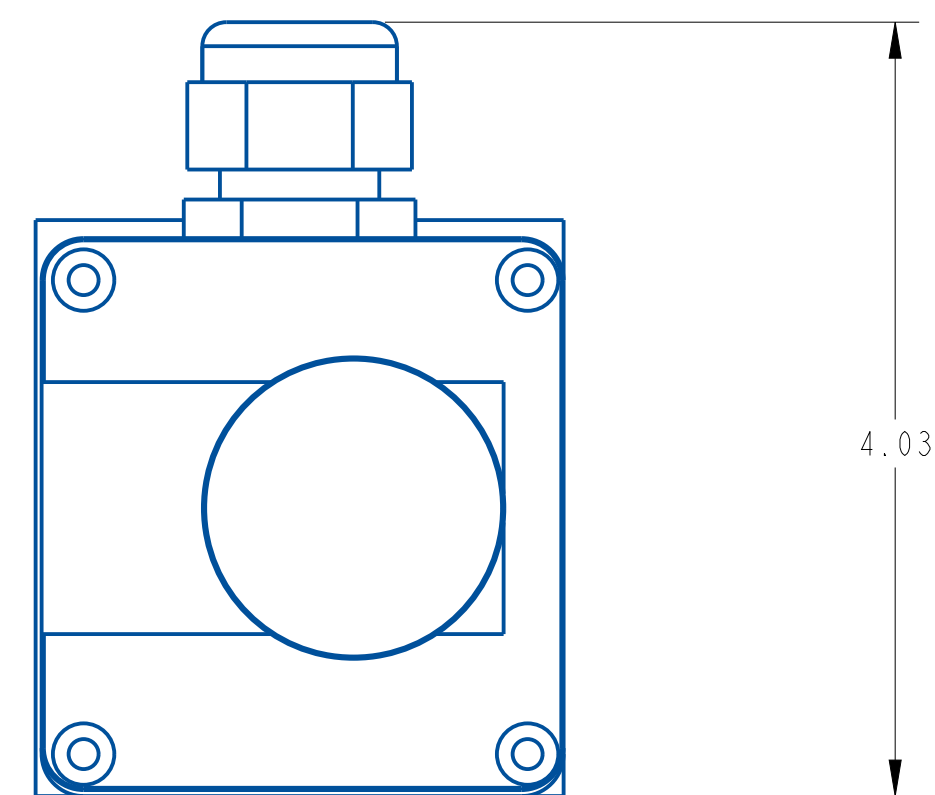
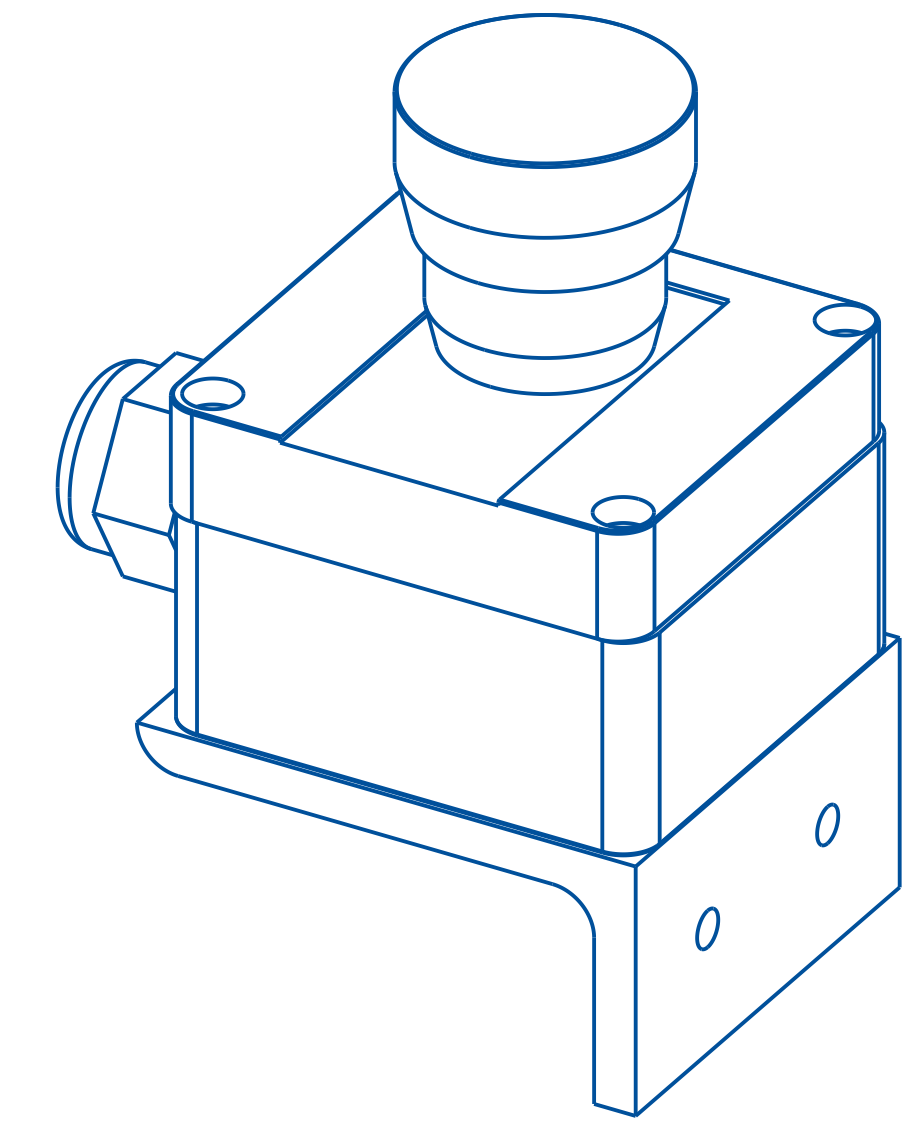
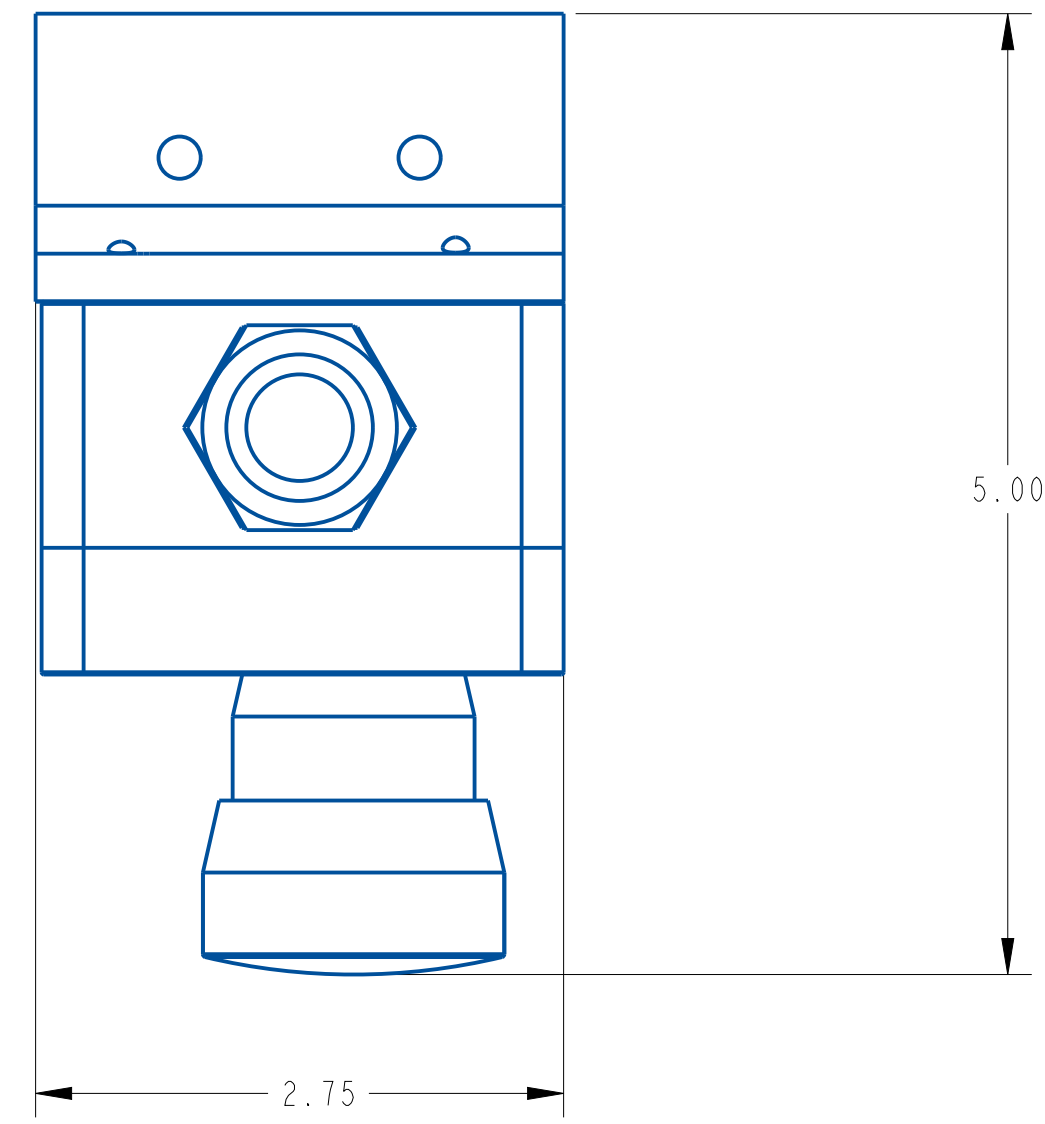

REV	DATE	DESCRIPTION	BY
A	8-29-16	NEW DRAWING	TJS

THIS IS A PRO-ENGINEER DOCUMENT AND MAY NOT BE MODIFIED MANUALLY

UNLESS OTHERWISE SPECIFIED DIMENSIONAL TOLERANCE	.XX ± .01 .XXX ± .005 ANGLES ± .30°	QUADREL LABELING SYSTEMS 7670 JENTHER DRIVE MENTOR, OHIO 44060 (440) 602-4700	SCALE: 1/1 DATE: 8-29-16 DRW BY: TJS CHK BY: 03/08/2024-SEM APPR BY:
EMERGENCY STOP ASSEMBLY			MAT'L
			20789-000

22287-001 ENCODER ASSEMBLY

MOUNTING ANGLE
A10284-000

ENCODER 1200PPR
202123-003



WHEEL .7" W X 12"
CIRC.
202925-000

CONNECTOR
252019-000

--	22513-004	2	Servo Cables, 5m
--	222390-002	1	Enclosure, 30x30x8, SS
--	222286-000	1	Panel, 30x30
--	241187-001	2	Fuse, 15A, CC
--	251799-000	4	End Cap
--	251856-000	1	3-Pole Jumper
--	251855-000	6	2-Pole Jumper
--	251858-000	4	5 Position Jumper, ST1.5
--	251859-000	2	10 Position Jumper, ST1.5
--	251853-000	120	Terminal Block, ST1.5, Spring
--	251854-000	20	Ground Terminal, ST1.5
--	251795-000	16	Phoenix Contact 3022276 End Terminal
--	251798-000	4	Partition Plate
--	251803-000	2	4 Position Jumper, ST2.5
--	251797-000	8	Phoenix Contact Terminal Block, ST2.5
--	251796-000	2	Phoenix Contact 3031238 Ground Terminal, ST2.5
--	241085-001	2	Fuse, DC, 10A
--	262822-000	1	Ethernet Cable, 1 ft
21	221650-005	1	Phoenix 1301402 Safety Relay
20	221678-000	1	Regeneration Clamp
19	251788-001	2	Fuse Holder, 300V, Indicating
18	211548-003	1	Power Supply, 48V, 10A
17	221719-000	1	PLC Ethernet Module
16	221720-008	1	PLC Expansion Module, 16 Out
15	221720-007	1	PLC Expansion Module, 16 In
14	221718-000	1	PLC Expansion Adapter
13	221717-001	1	PLC, Keyence KV-N24DTP
12	221682-000	1	Ethernet Switch, 5 Port
11	202628-000	3	Relay, 24V, Single
10	262822-006	2	Cable, Cat5, 2ft
9	411458-001	2	AC Drive, Fuji Mini, 220V, 1 HP, 4.2A
8	211528-005	1	24VDC Supply, 2.5A
7	202607-000	1	Contactors Surge Suppressor, Altech AS-12M/4
6	202604-000	1	Contactors, 24V, 12A, Altech GMD-12M-10-DC24V
5	241166-001	1	Circuit Breaker, 2 Pole, 3A
4	241319-001	3	Circuit Breaker, 2 Pole, 6A
3	272117-003	1	Disconnect, 25A Base Mount
2	241285-000	2	Fuse Holder, CC
1	251830-002	1	Ground Bar

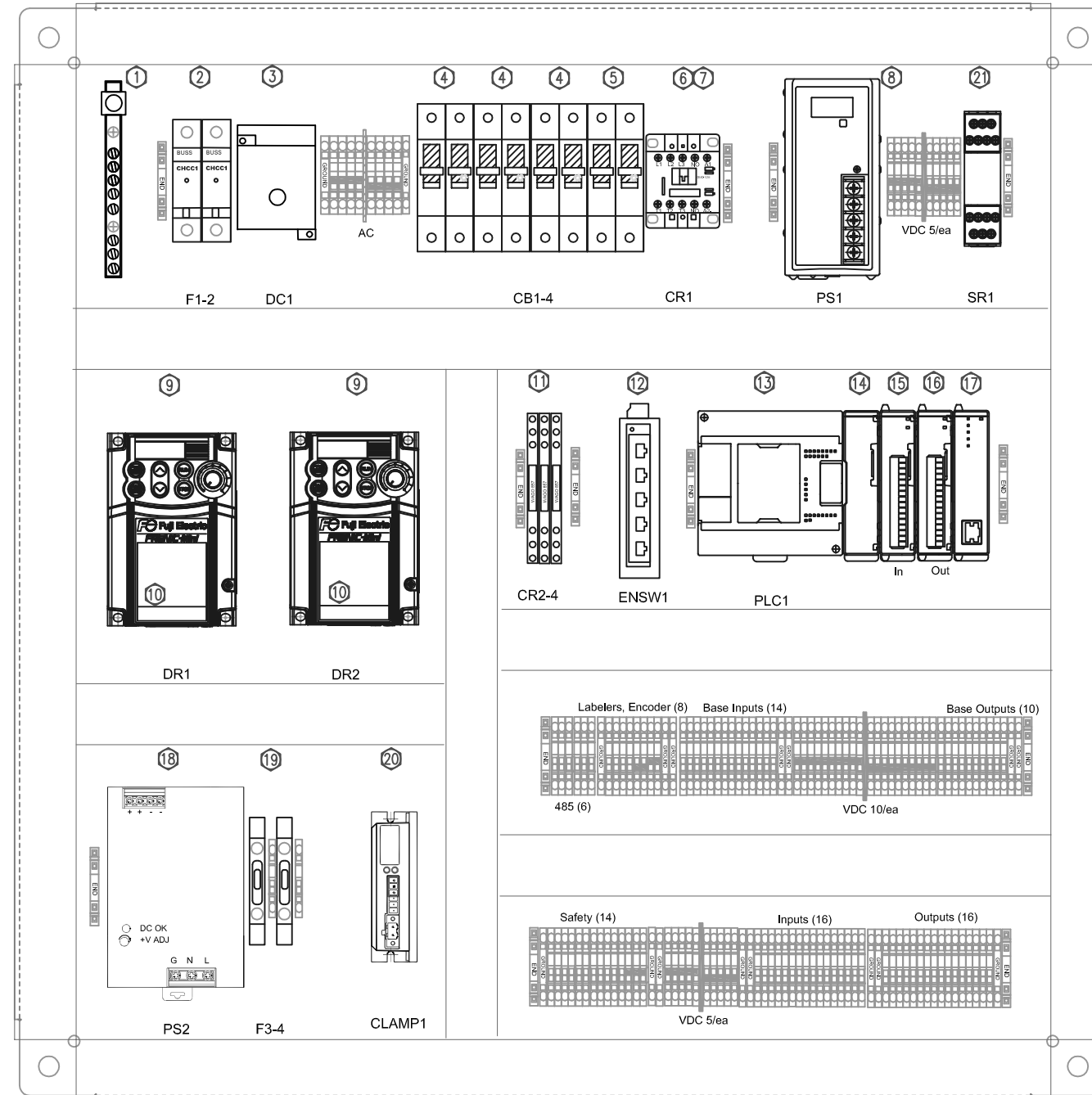

3/4" Wireway Unless Noted
Component Hardware: 8-32 SHCS
Wireway/Din Rail Hardware: 8-32 BHCS

UNLESS OTHERWISE SPECIFIED DIMENSIONAL TOLERANCE X ± .XTOL XX ± .XXTOL XXX ± .XXXTOL ANGLES ± .ANGTOL SURFACE FINISH FINISHTOL BREAK ALL EDGES .005/.015 CORNER RADIUS .010/.030	QUADREL LABELING SYSTEMS 7670 Jenther Drive Mentor, Ohio 44060 (440) 602-4700	SCALE: 1:1
		DATE: 18DEC2025
		DRAWN BY: CAV
		REVISED:
	Layout, Custom	
	MAT'L 84263E-000	B84263-000P

220V, 1PH, 15A

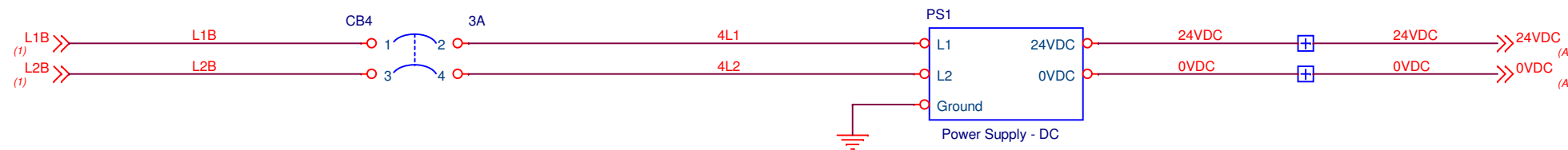
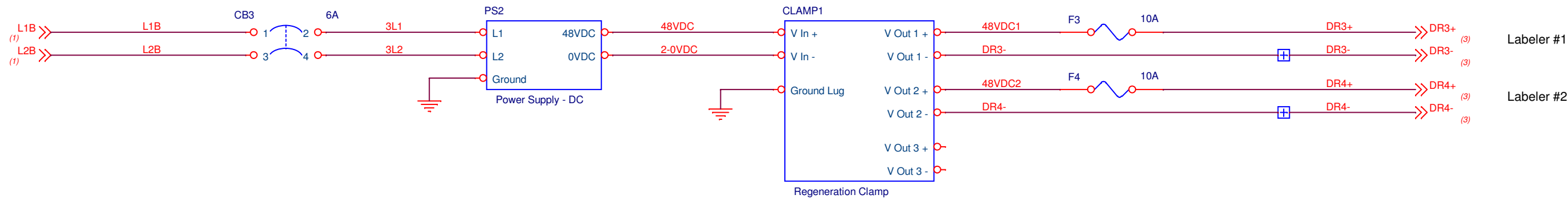
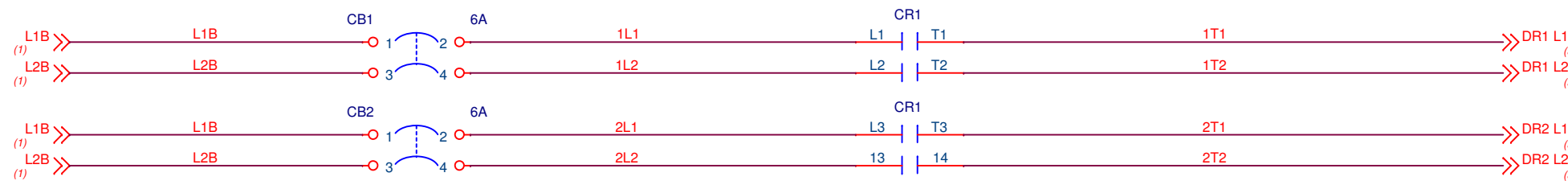
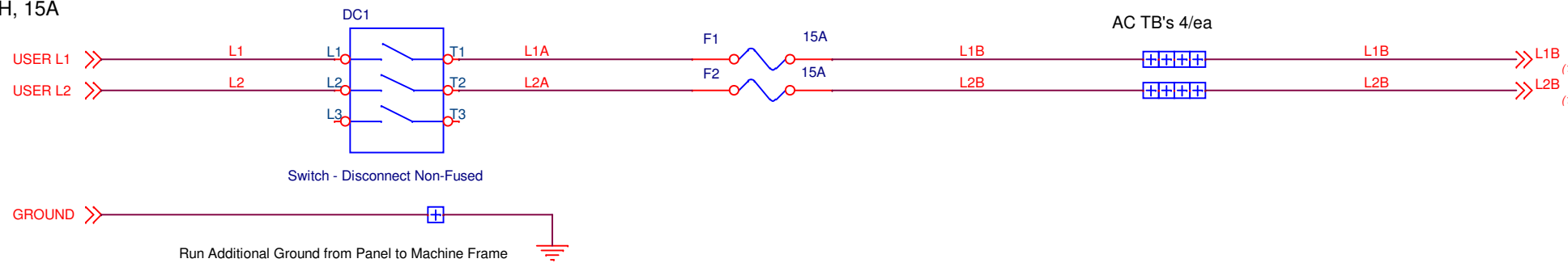

COLOR	TECHNICIAN	DATE

For Quadrel Assembly Use

QUADREL LABELING SYSTEMS
7670 JENTHER DR.
MENTOR, OH 44060

Drawn By: CAV
Title: **POWER**

REV	DESCRIPTION	CAV	19DEC2025

Schematic # **5884263-000** Rev -

Date: Friday, December 19, 2025 | Sheet 01 of 08

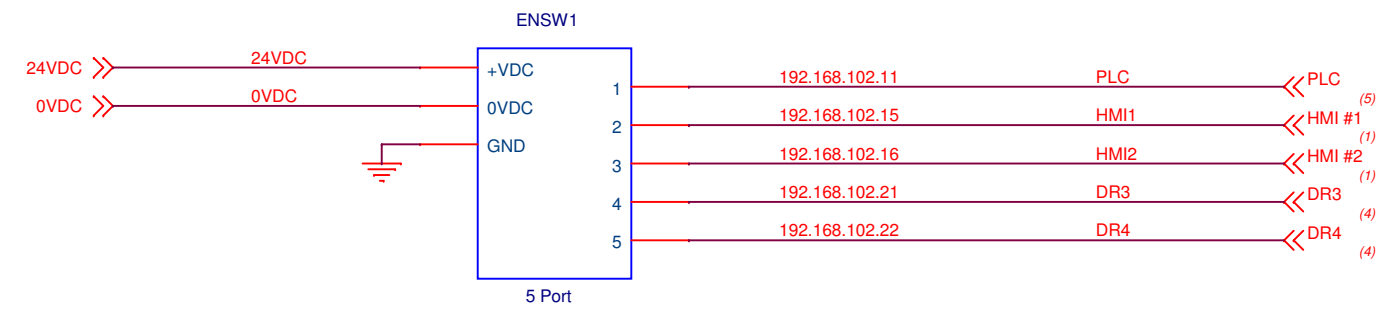
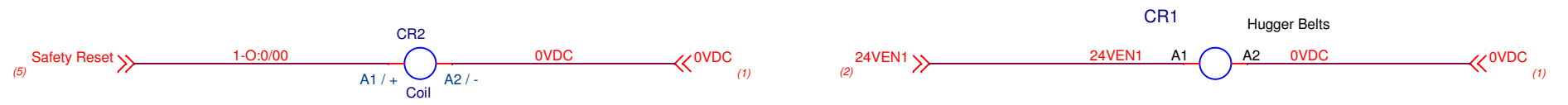
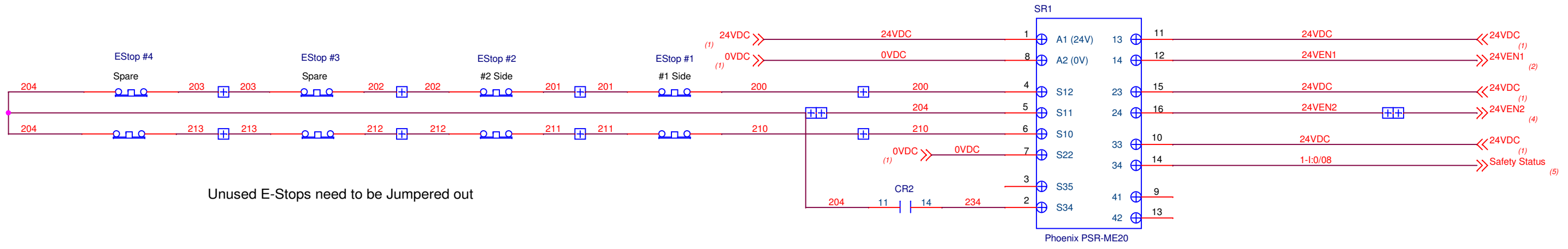

COLOR	TECHNICIAN	DATE

For Quadrel Assembly Use

QUADREL LABELING SYSTEMS
7670 JENTHER DR.
MENTOR, OH 44060

Drawn By: CAV	REVISION	DESCRIPTION	CAV	19DEC2025
Title		SAFETY, NETWORK		
Schematic #				Rev
5884263-000				-
Date: Friday, December 19, 2025		Sheet 02 of 08		

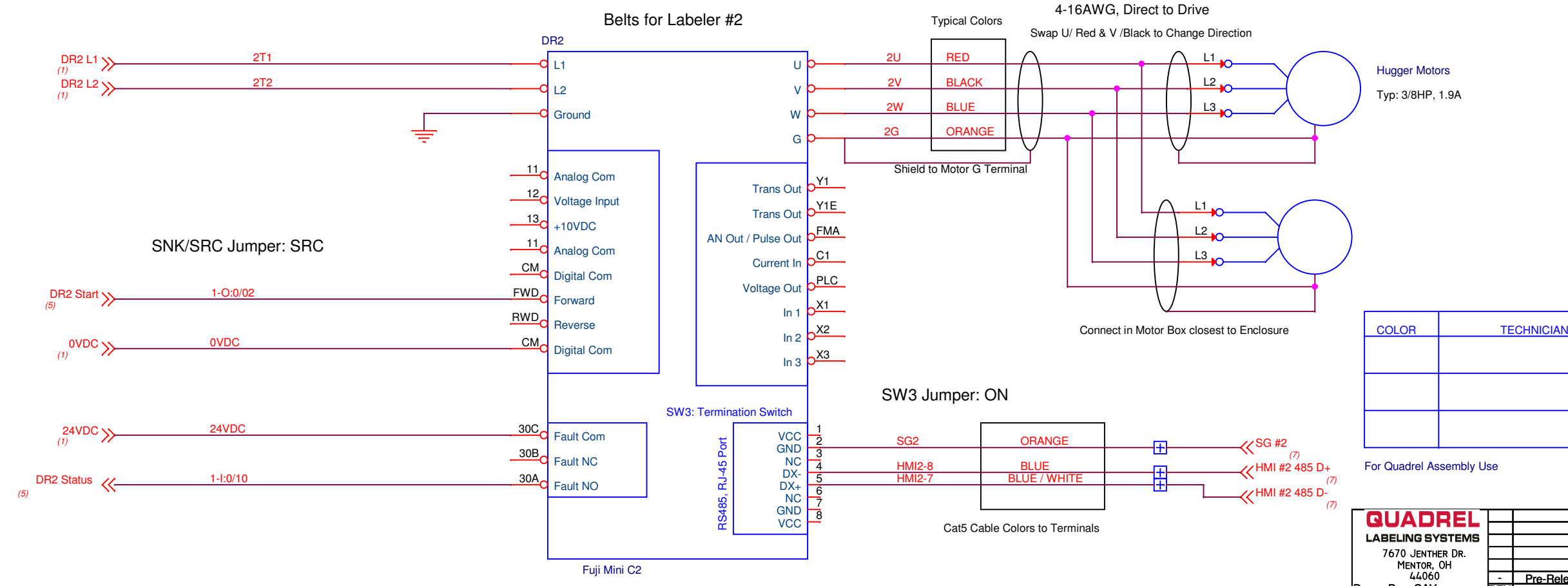
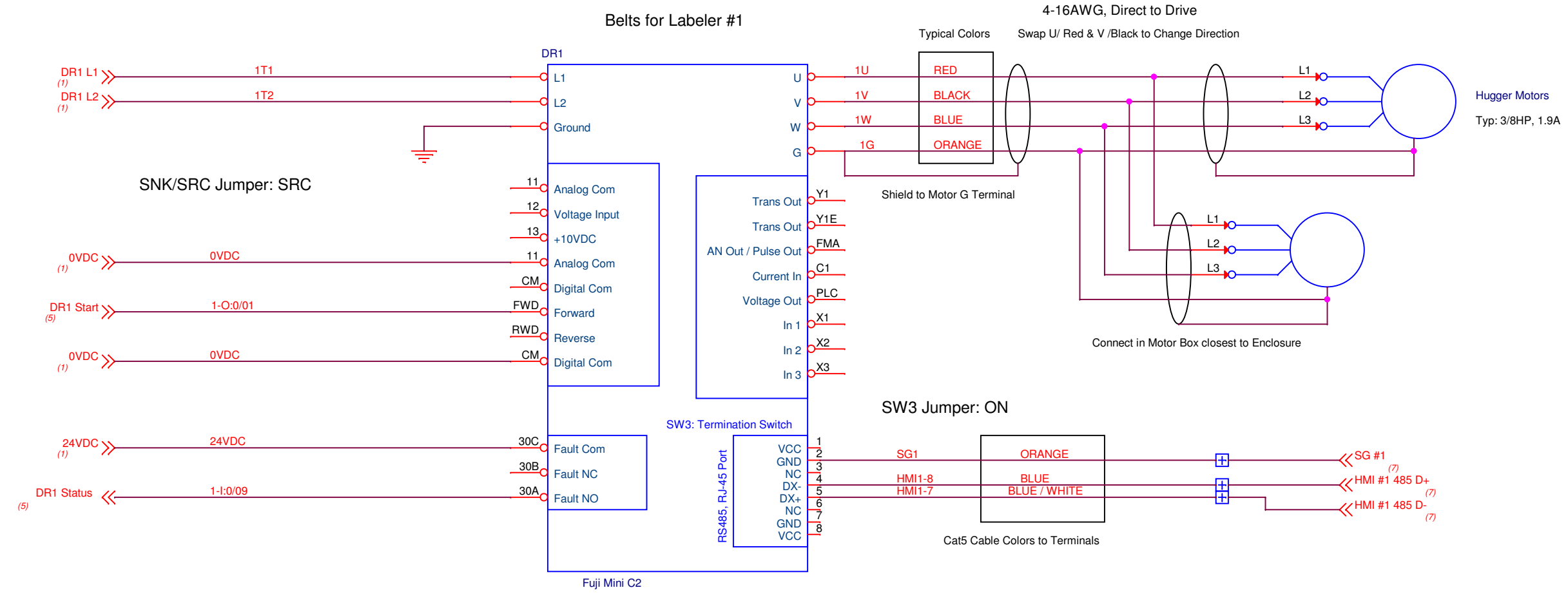

COLOR	TECHNICIAN	DATE

For Quadrel Assembly Use

QUADREL LABELING SYSTEMS
7670 JENTHER DR.
MENTOR, OH 44060

Drawn By: CAV
Title: **HUGGER DRIVES**

Schematic # **5884263-000**

Date: Friday, December 19, 2025 | Sheet 03 of 08

REV	DESCRIPTION	CAV	DATE
-	Pre-Release	CAV	19DEC2025

Labeler #1

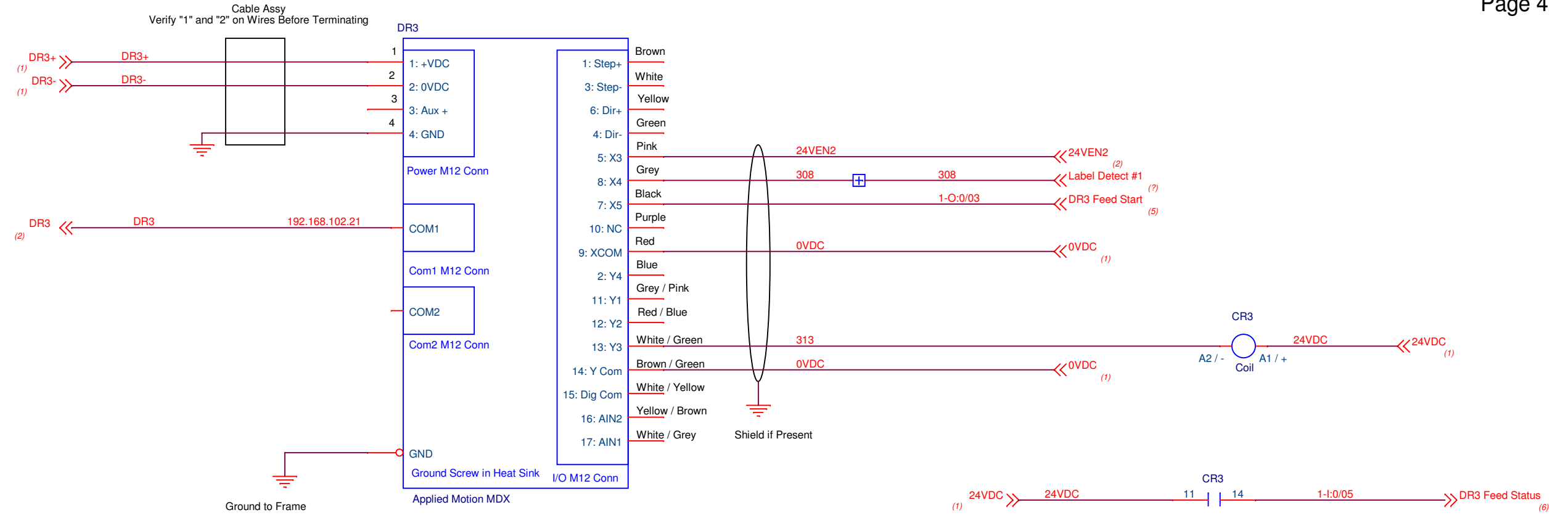

Labeler #2

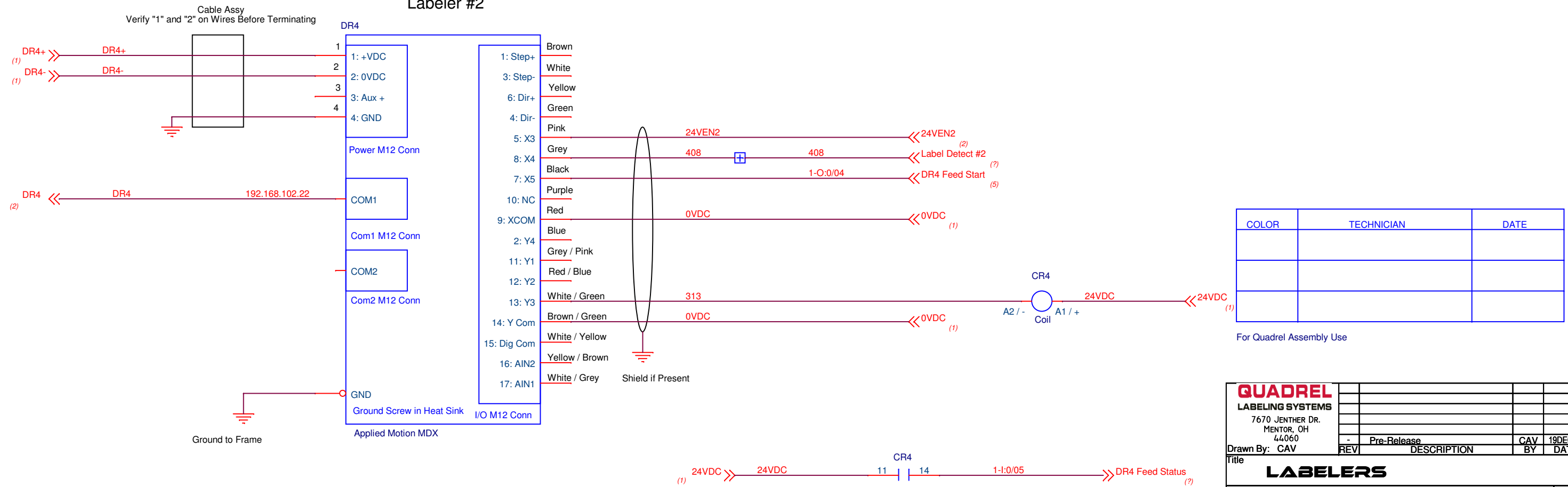

COLOR	TECHNICIAN	DATE

For Quadrel Assembly Use

QUADREL LABELING SYSTEMS
7670 JENTHER DR.
MENTOR, OH 44060

Drawn By: CAV
Title: LABELERS
Schematic #: 5884263-000

REV	DESCRIPTION	CAV	19DEC2025
-	Pre-Release	BY	DATE

Date: Friday, December 19, 2025 | Sheet 04 of 08

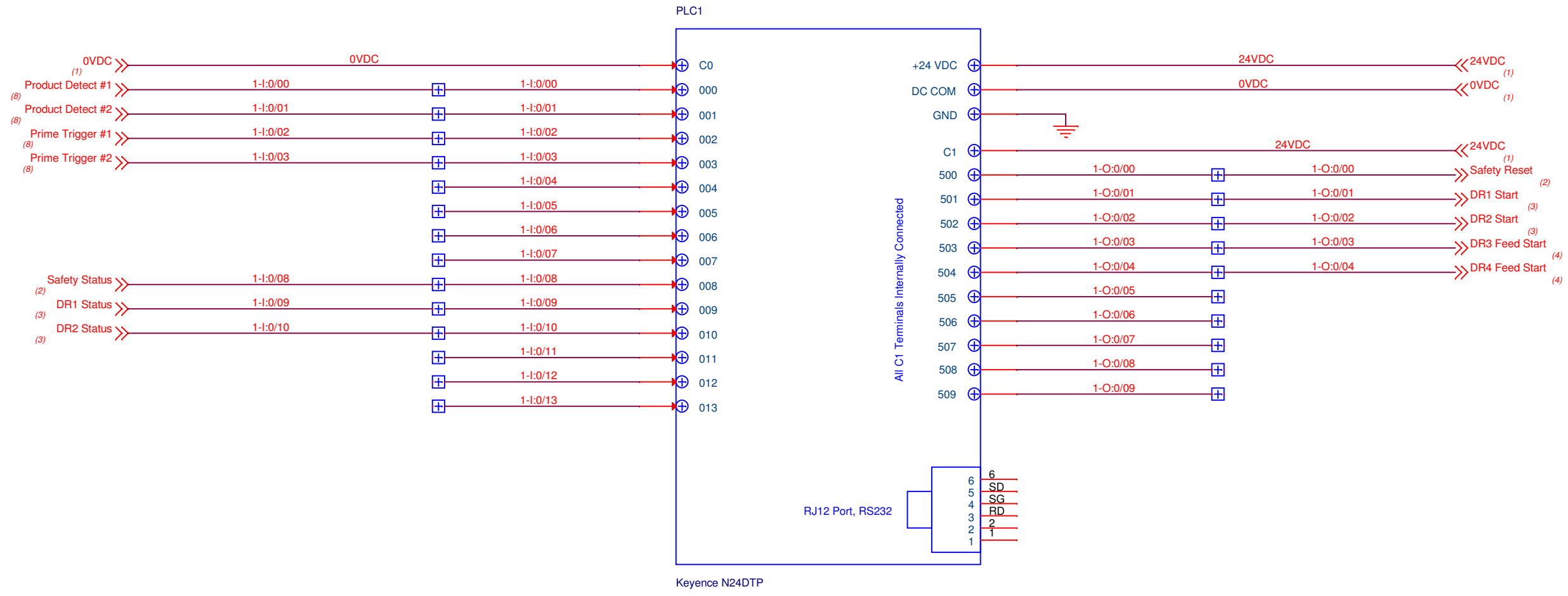

COLOR	TECHNICIAN	DATE

For Quadrel Assembly Use

QUADREL
LABELING SYSTEMS
7670 JENTHER DR.
MENTOR, OH
44060

Drawn By: CAV	REVISION	DESCRIPTION	CAV	19DEC2025

Title: **PLC BASE**

Schematic #: **5884263-000**

Date: Monday, January 05, 2026 | Sheet 05 of 08

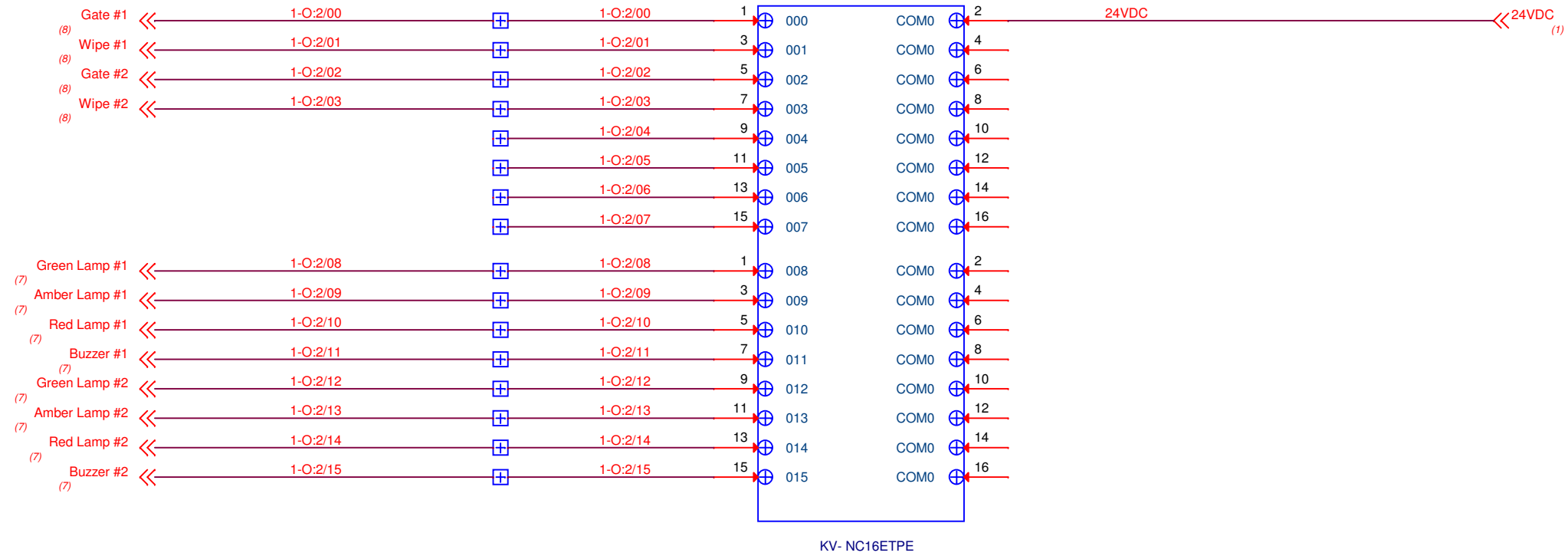
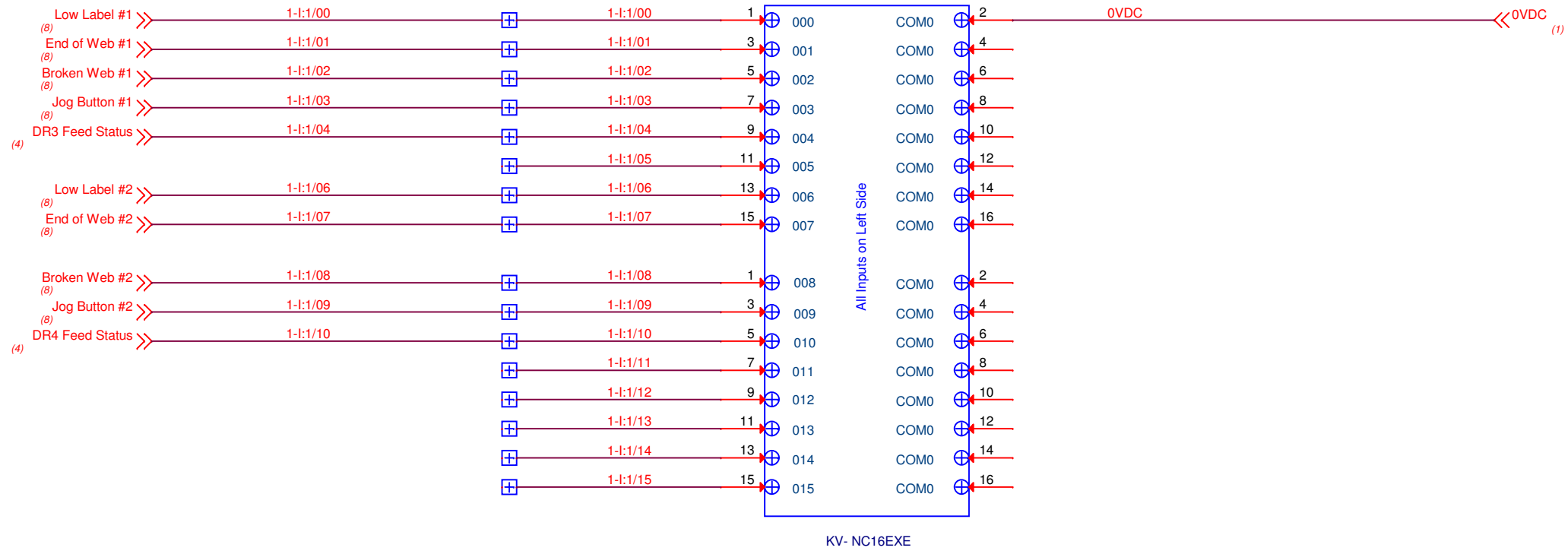

COLOR	TECHNICIAN	DATE

For Quadrel Assembly Use

QUADREL
 LABELING SYSTEMS
 7670 JENTHER DR.
 MENTOR, OH
 44060

Drawn By: CAV	REV	DESCRIPTION	CAV	19DEC2025
Title		PLC EXPANSION		
Schematic #				Rev
5884263-000				-
Date: Friday, December 19, 2025		Sheet 06 of 08		

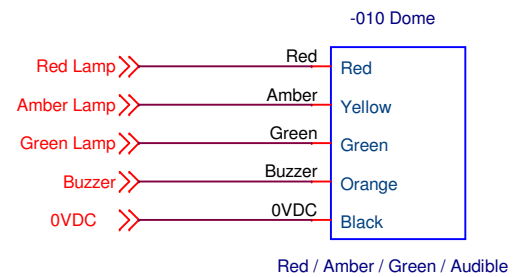
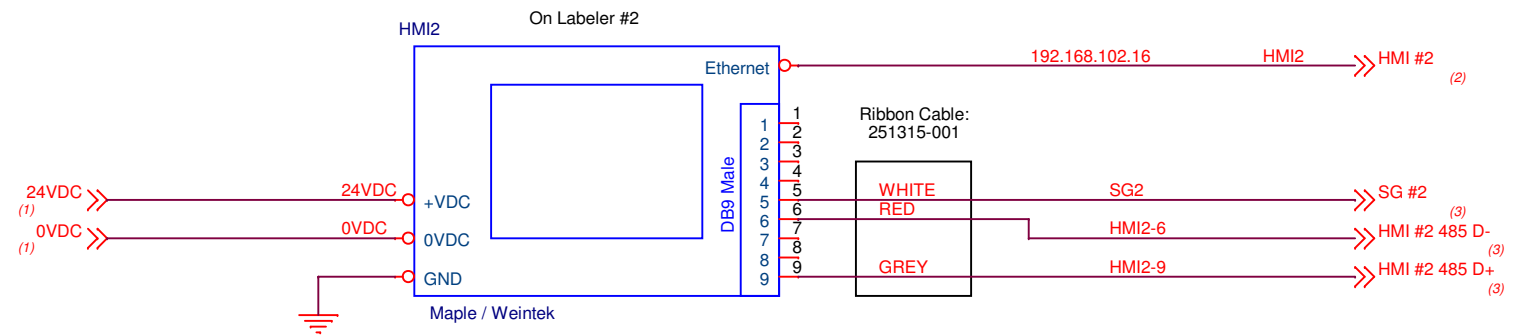
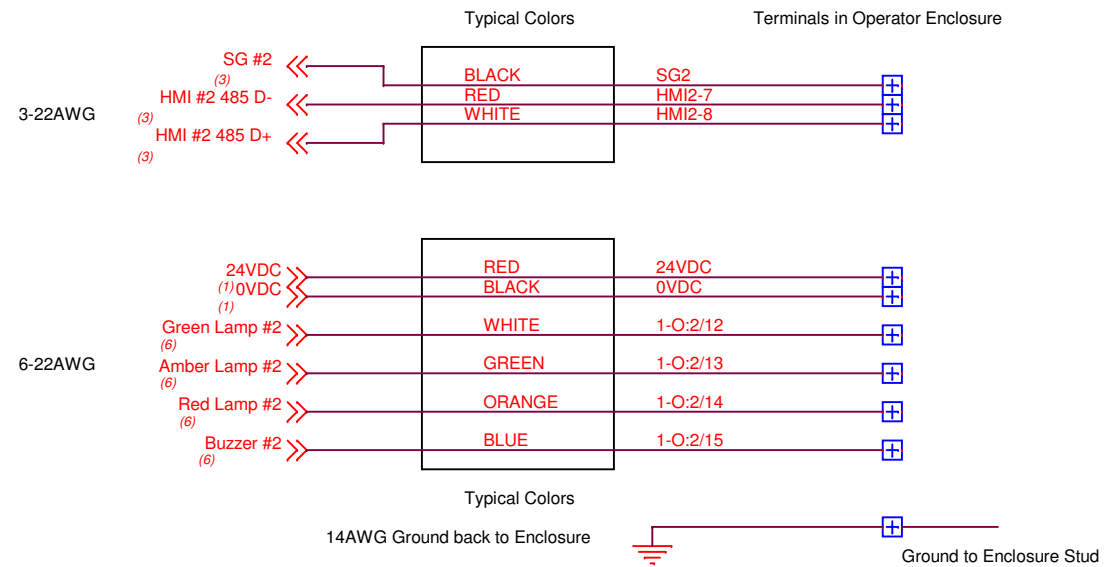
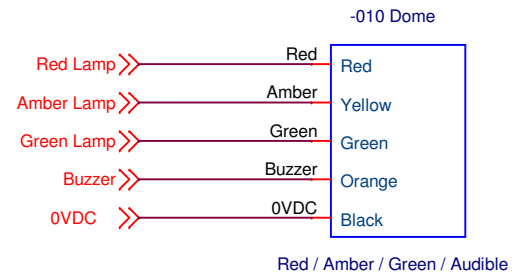
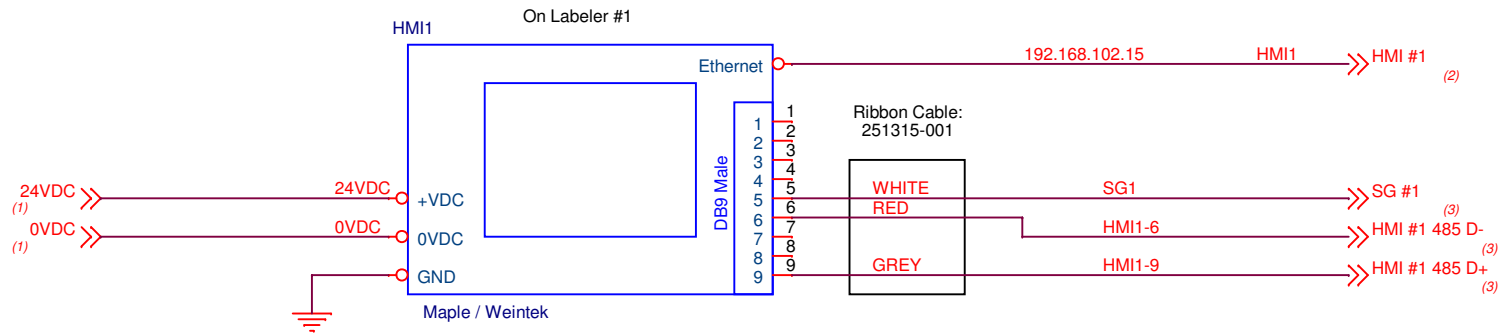
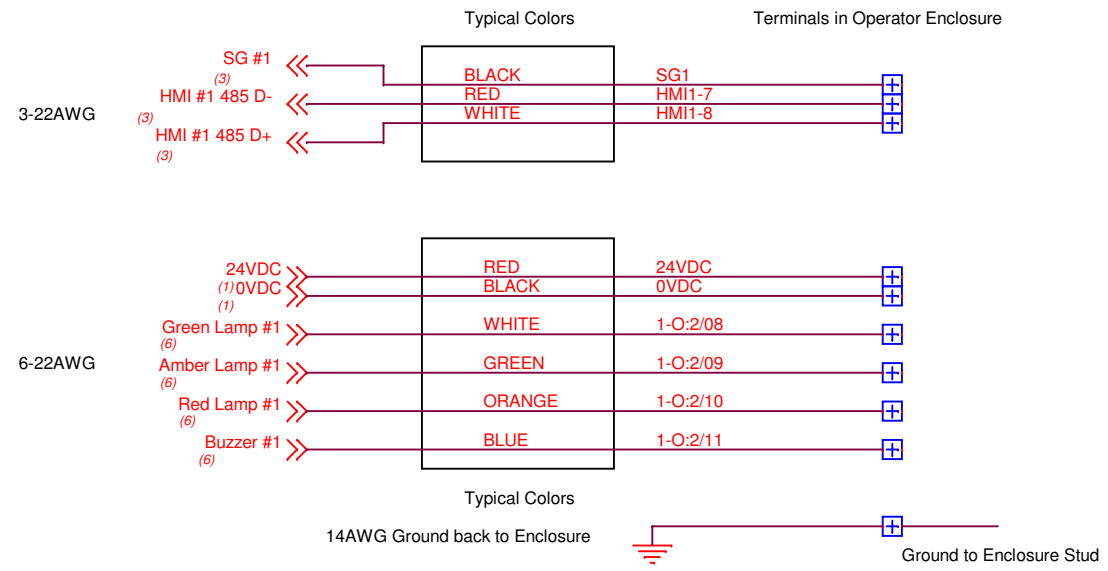

COLOR	TECHNICIAN	DATE

For Quadrel Assembly Use

QUADREL LABELING SYSTEMS
7670 JENTHER DR.
MENTOR, OH 44060

Drawn By: CAV	REVISION	DESCRIPTION	CAV	19DEC2025
Title		OPERATOR ENCLOSURES		
Schematic #		5884263-000		Rev
				-
Date: Tuesday, March 03, 2026		Sheet 07 of 08		

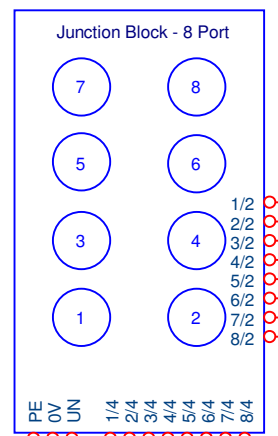

All Sensors: PNP

Port #	Sensor	Labeler #1	Labeler #2
#1	Product Detect	1-I:0/00	1-I:0/01
#2	Label Detect	308	408
#3	Low Label	1-I:1/00	1-I:1/06
#4	End of Web	1-I:1/01	1-I:1/07
#5	Broken Web	1-I:1/02	1-I:1/08
#6	Jog Button	1-I:1/03	1-I:1/09
#7	Prime Trigger	1-I:0/02	1-I:0/03
#8	Gate	1-O:2/00	1-O:2/03

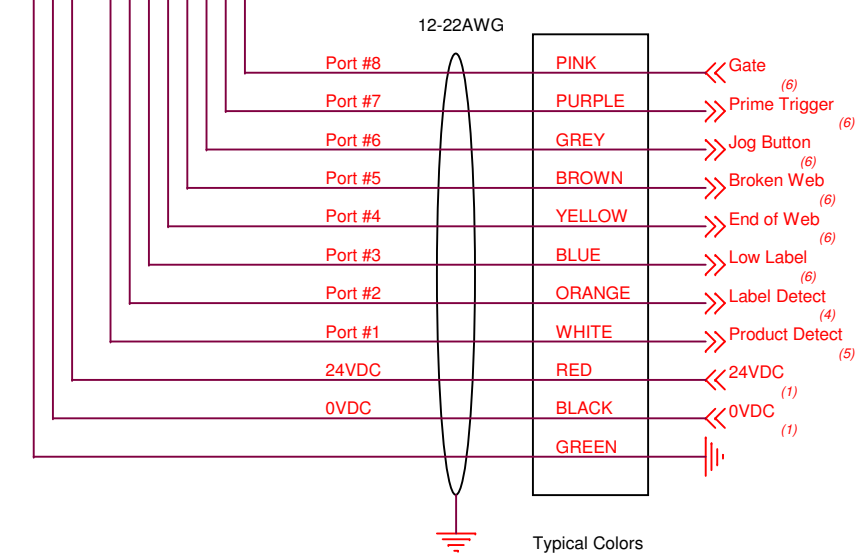

Ground from Sideplate to Enclosure Panel

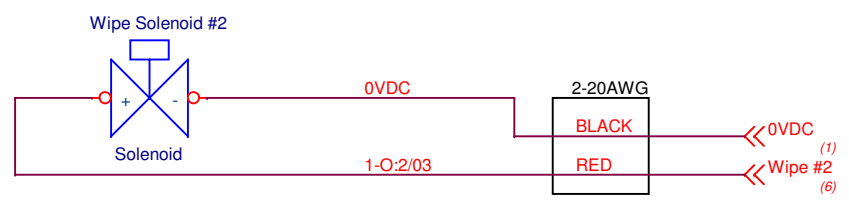
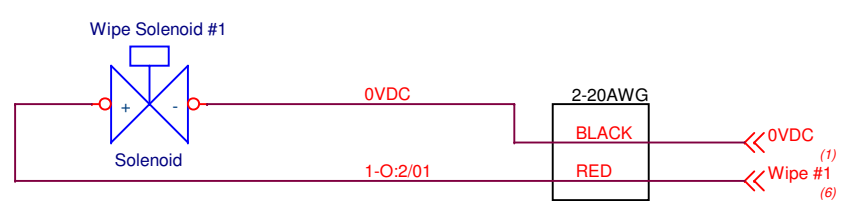
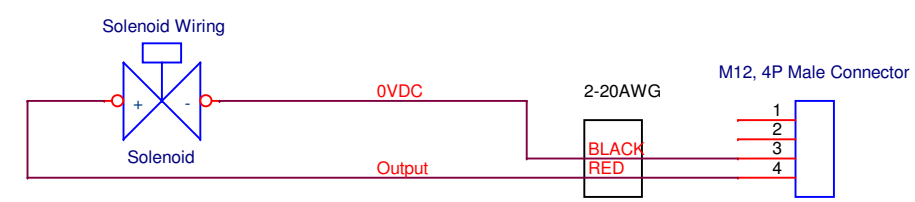
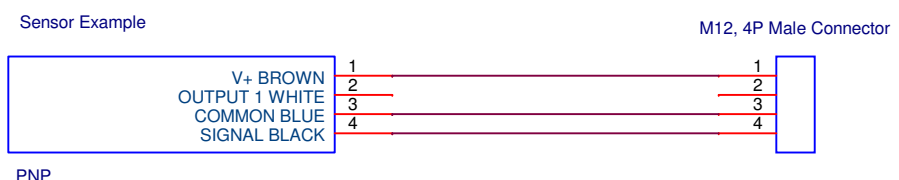

QUADREL			
LABELING SYSTEMS			
7670 JENTHER DR.			
MENTOR, OH			
44060			
Drawn By: CAV	REV	DESCRIPTION	DATE
	-	Pre-Release	19DEC2025
SENSORS			
Schematic #			Rev
5884263-000			-
Date: Friday, December 19, 2025			
Sheet			08 of 08

QUADREL LABELING SYSTEMS
INDENTED BILL OF MATERIAL

Items: 22513-004 Thru 22513-004 Location: 01 QUADREL WHSE

Activity Codes: Active Items Only

1 Levels With No Blow Through

No Selection On Basis Of Effectivity Date

No Selection On Basis Of Obsolete Date

Level	Seq	Component-Item	Component-Description	Loc	Opr	UOM	Scrap	Act	Stk	B/I	Qty On-Hand	Qty-Per-Parent
					LLC	Draw	REV	P/M	Ctl	B/F	Qty-Allocated	Qty-On-Order
=====												
Parent Item: 22513-004 CABLES AND JUNCTION BOX COMPS Loc: 01 LLC: 8												
FOR STEPSERVO HEADS, 5m												
1	5	252026-008	CABLE, ETHERNET, M12D LEAD, 5m		0	EA	.0	A	Y	N		1.000000
		"MENCOM"	MDE45-4MP-5M	01	9			P	Y	N		
1	10	252057-000	CONNECTOR, RJ45, CAT5, PLUG		0	EA	.0	A	Y	N		1.000000
		"BOMAR"	300568EZ ***	01	9			P	Y	N		
1	15	203199-000	CABLE, M12S FEM 4P, 5m		0	EA	.0	A	Y	N		1.000000
		"PHOENIX"	1408837	01	9			P	Y	N		
1	20	203325-000	CABLE, M12 17P, M, 5m		0	EA	.0	A	Y	N		1.000000
		"APPLIED MOTION"	3004-333-5M	01	9			P	Y	N		
1	50	252019-000	CONNECTOR, M12, 4P, MALE		0	EA	.0	A	Y	N		1.000000
		"LUMBERG"	RSC4/7	01	10			P	Y	N		
1	55	252065-001	JUNCTION BLOCK, 8 PORT, LED		0	EA	.0	A	Y	N		1.000000
		"P+F"	V1-8/16A-E2	01	9			P	Y	N		
1	60	272196-000	SWITCH, N.O. CONTACT BLOCK		0	EA	.0	A	Y	N		1.000000
		"ALLEN BRADLEY"	800F-X10	01	9			P	Y	N		
1	65	272195-000	SWITCH, LATCH FOR 800FP SERIES		0	EA	.0	A	Y	N		1.000000
		"ALLEN BRADLEY"	800F-ALP	01	9			P	Y	N		
1	70	272206-000	SWITCH, CAP ONLY, GREEN "JOG"		0	EA	.0	A	Y	N		1.000000
		"ALLEN BRADLEY"	800F-AF3CE138	01	9			P	Y	N		
1	75	272181-000	SWITCH, PUSH, BLACK, FLUSH		0	EA	.0	A	Y	N		1.000000
		"ALLEN BRADLEY"	800FP-F2	01	9			P	Y	N		
1	80	241803-000	STRAIN RELIEF, M16, W/NUT		0	EA	.0	A	Y	N		1.000000
		"HEYCO"	M4334	01	9			P	Y	N		
1	85	221152-003	ENCLOSURE, 22mm HOLE, WHITE		0	EA	.0	A	Y	N		1.000000
		"BACO"	LBX0100	01	9			P	Y	N		

QUADREL LABELING SYSTEMS
INDENTED BILL OF MATERIAL

Items: 84263E1-000 Thru 84263E1-000 Location: 01 QUADREL WHSE

Activity Codes: Active Items Only

1 Levels With No Blow Through

No Selection On Basis Of Effectivity Date

No Selection On Basis Of Obsolete Date

Level	Seq	Component-Item	Component-Description	Loc	Opr	UOM	Scrap	Act	Stk	B/I	Qty On-Hand	Qty-Per-Parent	
					LLC	Draw	REV	P/M	Ctl	B/F	Qty-Allocated	Qty-On-Order	
=====													
Parent Item:		84263E1-000	ELECTRICAL, OPERATOR ENCL	Loc:	01	LLC:	1						
			ENVIRO-TEX										
1	5	B7702-014	MODIFICATION, OVERHEAD ENCL.		0	EA	.0	A	Y	N		1.000000	
		USE QLS 222399-000		01	8			M	Y	N			
1	10	222399-000	ENCLOSURE, INTERFACE, 12x8x6		0	EA	.0	A	Y	N		.000000	
		"RITTAL" CP 6320.050 **		01	9			P	Y	N			
1	20	251853-000	TERMINAL BLOCK, ST 1.5 GREY		0	EA	.0	A	Y	N		11.000000	
		"PHOENIX CONTACT" 3031076		01	9			P	Y	N			
1	25	251854-000	GROUND TERMINAL BLOCK, ST 1.5		0	EA	.0	A	Y	N		1.000000	
		"PHOENIX CONTACT" 3031513		01	9			P	Y	N			
1	30	251799-000	COVER PLATE, ST1.5 - 2.5		0	EA	.0	A	Y	N		1.000000	
		"PHOENIX CONTACT" 3030417		01	9			P	Y	N			
1	35	251798-000	PARTITION PLATE, ST1.5 - 4		0	EA	.0	A	Y	N		1.000000	
		"PHOENIX CONTACT" 3030721		01	9			P	Y	N			
1	40	251795-000	END BRACKET, SNAP-ON		0	EA	.0	A	Y	N		2.000000	
		"PHOENIX CONTACT" 3022276		01	9			P	Y	N			
1	45	262822-015-DN	CABLE, CAT6, DOWN ANGLE, 15FT		0	EA	.0	A	Y	N		1.000000	
		"TRIPP LITE" N204-S15-BL-DN		01	7			P	Y	N			
1	50	251855-000	2 POLE JUMPER, ST 1.5		0	EA	.0	A	Y	N		2.000000	
		"PHOENIX CONTACT" 3030116		01	9			M	Y	N			
1	55	251315-001	CABLE, DB9 MALE TO LEADS, 6'		0	EA	.0	A	Y	N		1.000000	
		"ASSMANN" H7PXH-0906M		01	7			P	Y	N			
1	60	222416-000	COUPLING, ROTATING, 130MM		0	EA	.0	A	Y	N		1.000000	
		"RITTAL" 6206.300		01	6			P	Y	N			
1	65	222416-001	COUPLING, FIXED, 130MM		0	EA	.0	A	Y	N		1.000000	
		"RITTAL" 6206.320		01	6			P	Y	N			
1	70	221700-002	HMI, 7", SERIAL, ETHERNET		0	EA	.0	A	Y	N		1.000000	
		"WEINTEK" cMT2078X		01	8			P	Y	N			

9 MAINTENANCE

9.1 GENERAL INFORMATION

This labeler has been designed with the minimal maintenance requirement possible. There are however some things to take into consideration.

The system is built to perform in humid conditions, but must not be pressure washed. In case of wash down conditions, it is recommended to cover each labeling head with a plastic tarp.

For the overall cleaning, it is recommended to use compressed air and clean, damp wipes.

Always turn off the system before proceeding with cleaning and maintenance.

The following section explains the preventive maintenance for each section

After every 100 hours of operation, a visual inspection of the system should be done and where it is necessary, lubricate and cleaning should be performed.



CAUTION

WEAR PROTECTIVE EYEWEAR when performing any maintenance on this equipment.



CAUTION

To reduce risk of fire, electrocution or other personal Injury when operating or maintaining the labeling head, follow basic safety precaution, including the following:

DO NOT perform any servicing or maintenance with the power ON.

Always disconnect the electrical plug from the wall socket

Make sure that the power is OFF or that the available E-stop buttons have been activated.

LABELING SYSTEM

This labeling system is reliable, versatile and durable. It will operate for years with very light maintenance if it is performed regularly. Most of the maintenance takes only a few minutes and substantially increases the operational life of the system and maintains label placement accuracy.

Not all sections may apply to your equipment.

Daily:	D
Weekly:	W
Monthly	M
Quarterly	Q
Semi-Annually	S

ASSEMBLY TITLE: LABELING HEAD ASSEMBLY

D- Remove glue residue and labels from all rollers and idler. DO NOT use a knife or other tool to scrape the rollers. Adhesive Remover such as Goo-Gone or 3M Adhesive Remover is recommended. DO NOT use an adhesive remover that reacts with plastics or sensor lenses will be damaged.

M- Check for loose idlers and components and tighten as needed.

S – Lubricate all idler rollers shafts using 80w-90w gear lube on the white bearings where they contact the axle.

ASSEMBLY TITLE: UNWIND ASSEMBLY

S- Check and adjust dancer spring. If final spring tension is too soft then replace.

S- Check and inspect band brake. Replace if torn

ASSEMBLY TITLE: REWIND ASSEMBLY

S- Check and inspect friction disc (if applicable), Replace when worn out.

S- Check Kinetrol (if applicable) for leaks, Replace if necessary.

ASSEMBLY TITLE: BRAKE BRUSH ASSEMBLY

S- Reverse brake brush direction

S- Inspect Brake brush when brush body contour no longer viable or bristles are worn down. Replace

ASSEMBLY TITLE: SLOT SENSOR ASSEMBLY

D- Keep the sensor optical area clean from label and glue residue

ASSEMBLY TITLE: SIDE PLATE ASSEMBLY

S- Lubricate all idler rollers shafts using 80w-90w gear lube on the white bearings where they contact the axle.

ASSEMBLY TITLE: PEEL PLATE ASSEMBLY

D- Clean all the parts that may acquire labels or glue residue. DO NOT use a knife or other tool to scrape the rollers. Adhesive removers are recommended.

W- Inspect Teflon tape on peel plate tip. Replace if the steel is exposed.

S – Lubricate all idler rollers shafts 80w-90w gear lube

ASSEMBLY TITLE: DRIVE AND PINCH ROLL ASSEMBLY

D- Remove glue residue and labels from drive roller. DO NOT use a knife or other tool to scrape the rollers. Isopropyl alcohol and adhesive removers are recommended.

W- Clean the knurled roll with a soft brass brush and adhesive remover.

M- Check and inspect drive roll. No play should be present when powered up. If there is a groove the width of the label liner, replace the worn roller.

M – Lubricate knurled roll shafts using 80w-90w gear lube.

S- Inspect and Lubricate, springs and slugs.

ASSEMBLY TITLE: ROLLER/BRUSH IMPRESSER

D- Check the rollers/brushes. They should be free of label flash, glue and debris. This will prevent jamming and web tears.

W- Check the foam rollers. If foam wear is noticeable, replace as necessary.

NOTE: Exercise caution when removing bad labels from foam. Careless removal can result in torn foam which may leave the labeler inoperable until the roller is replaced!

ASSEMBLY TITLE: OPERATOR PANEL

-No maintenance is required for the operator panel

-Occasionally, the keypad may be cleaned with any non-solvent based cleaning solution. Glass cleaner on a clean towel then wipe the membrane.

ASSEMBLY TITLE: ELECTRICAL

W- Check the foam filter for the fan. Clean or replace.

ASSEMBLY TITLE: CONVEYOR

D – Inspect conveyor chain for broken flights of table top chain

W – Inspect conveyor for labels / adhesive and remove as needed

S – Check gearbox oil levels and add as needed.

American Lubricants SHC-90W oil.

ASSEMBLY TITLE: FEEDSCREW

W – Remove glue residue and labels from feed screws

W – Lubricate internal feedscrew drive assembly, with multi-purpose grease.

S – Lubricate grease fittings / chains / bearings with quality multi-purpose grease – as needed

ASSEMBLY TITLE: VERTICAL ROLLER

W – Remove labels from rollers with adhesive remover / cleaner

W – Lubricate chains with food grade grease.

ASSEMBLY TITLE: EJECT STATION

D – Clean all parts that have acquired label or glue residue

ASSEMBLY TITLE: INFEEED / OUTFEED BANK SENSOR

W – Clean and glue residue or labels off sensor and/or reflectors

ASSEMBLY TITLE: SLEEVE

M – Drive rollers – Inspect for wear and clean with a citrus based adhesive removal

M – Inspect tension belts for cutter blade and cutter assembly for wear. Replace as needed.

M – Inspect cutter blades and bearings for wear. Replace as needed

M – Inspect perforation blades / bearings for wear and free of debris. Replace as needed.

S - Check, inspect, and grease all lead screws (threaded rods)

S – Inspect mandrel and bearings for wear. Ensure they spin freely
Replace as needed.

NOTES:

GENERAL PURPOSE FEEDSCREW LUBRICATION GUIDE

During your weekly maintenance of your Quadrel Labeling Systems equipment follow the steps below to ensure proper lubrication of the internal drive system for your feedscrew assembly.



Step 1 – Your dual feedscrews are connected inside the conveyor with a spline shaft assembly. First remove the chain so you have easy access to the this.



Step 2 – Open your feedscrews to your largest product. This will expose the spline assembly shaft that you will be applying the multi-purpose grease to.



Step 3 – Apply multi-purpose grease to the now exposed spline shaft assembly. Ensure to apply multi-purpose grease all the way around the spline shaft– Top, bottom and sides

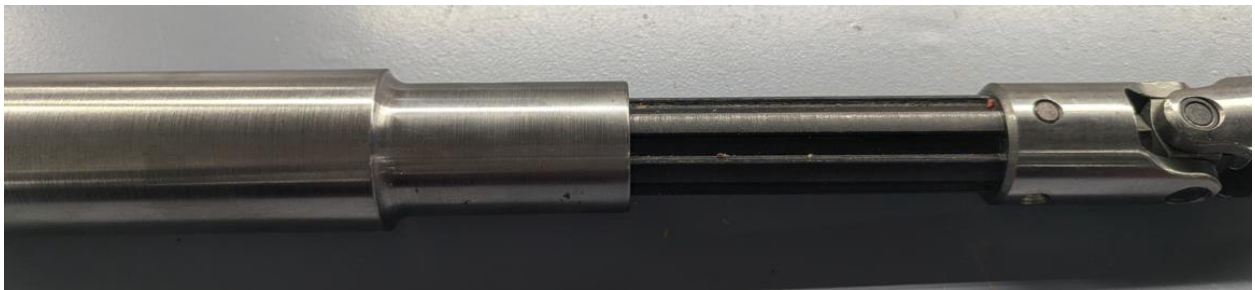

Step 4 – Slowly move the feedscrews in and out to so the grease can spread evenly over the length of entire spline shaft assembly.

Step 5 – Reconnect conveyor chain

Setup procedure for Powered rewind using MGC403-11-00MD drive

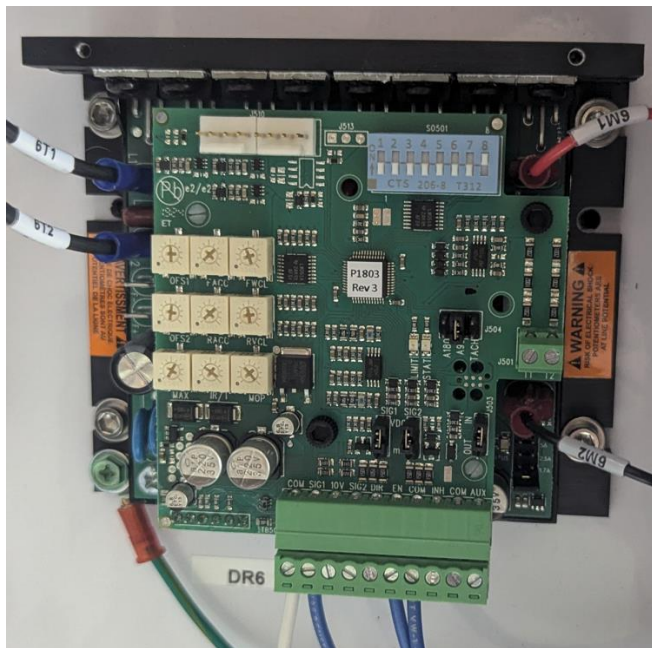

Upon receiving drive set the following **BEFORE** installing in the machine.

1. Dip switches - set all switches to the off position. This is the Light blue row of switches shown in the image below

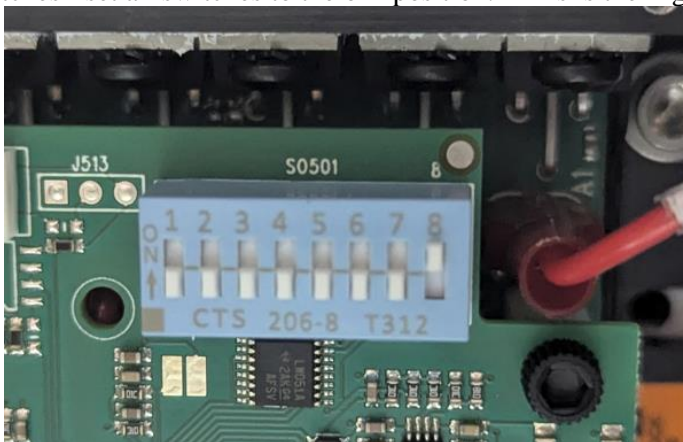

- a.
 2. Set Jumpers on drive based on electrical schematic for your machine
 - a. SIG1 – VDC
 - b. SIG2 – VDC
 - c. J504 – A90
 - d. AMP CURRENT – 1.7A – This located near the 10 pin green connector that

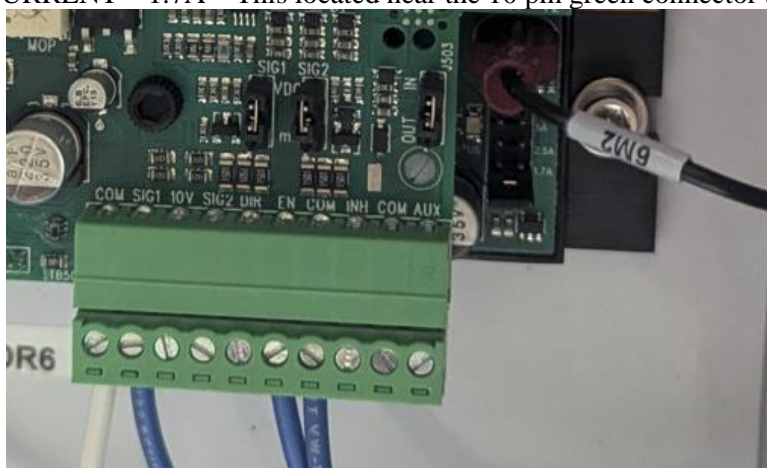

i.

3. Using a small flat blade / Slot screwdriver adjust the following pots as indicated in the image below:

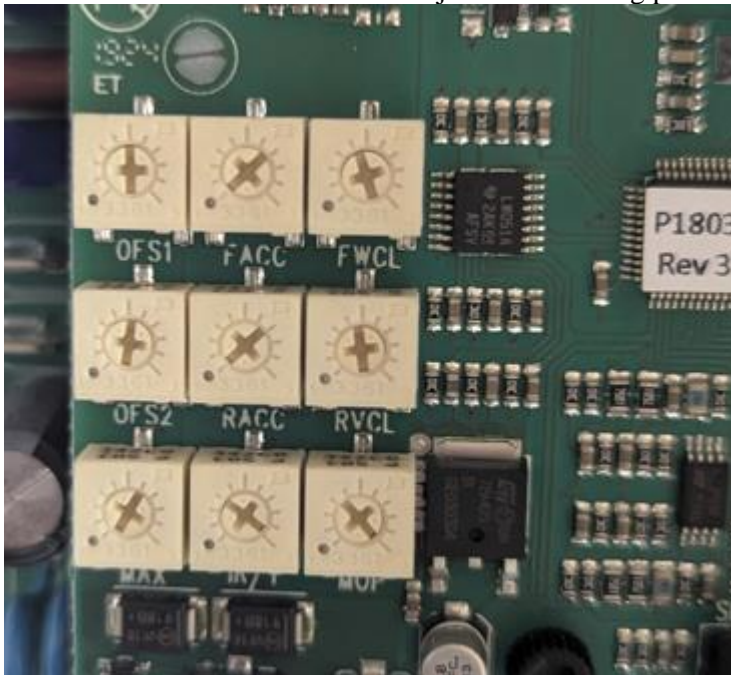

- a.
- i. Top row **OFS1** – WILL BE ADJUSTED AT LATER STEP
 - ii. Top row – **FACC** - turn counter clockwise until it stops.
 - iii. Top row **FWCL** – set to half way point – midpoint
 - iv. Middle row - **OFS2** – turn counter clockwise until it stops. This turns the pot OFF
 - v. Middle row – **RACC** - turn counter clockwise until it stops
 - vi. Middle row – **RVCL** – set to half way point – midpoint
 - vii. Bottom row – **MAX** – Set to 3/4 point
 - viii. Bottom row – **Leave other 2 pots at factory setting – DO NOT ADJUST**

4. Install drive in machine then proceed to next steps

5. Set the Cam on the rewind dancer per image below when the dancer arm is at rest. Rest is when the arm is all the way back against the rubber bumper as shown

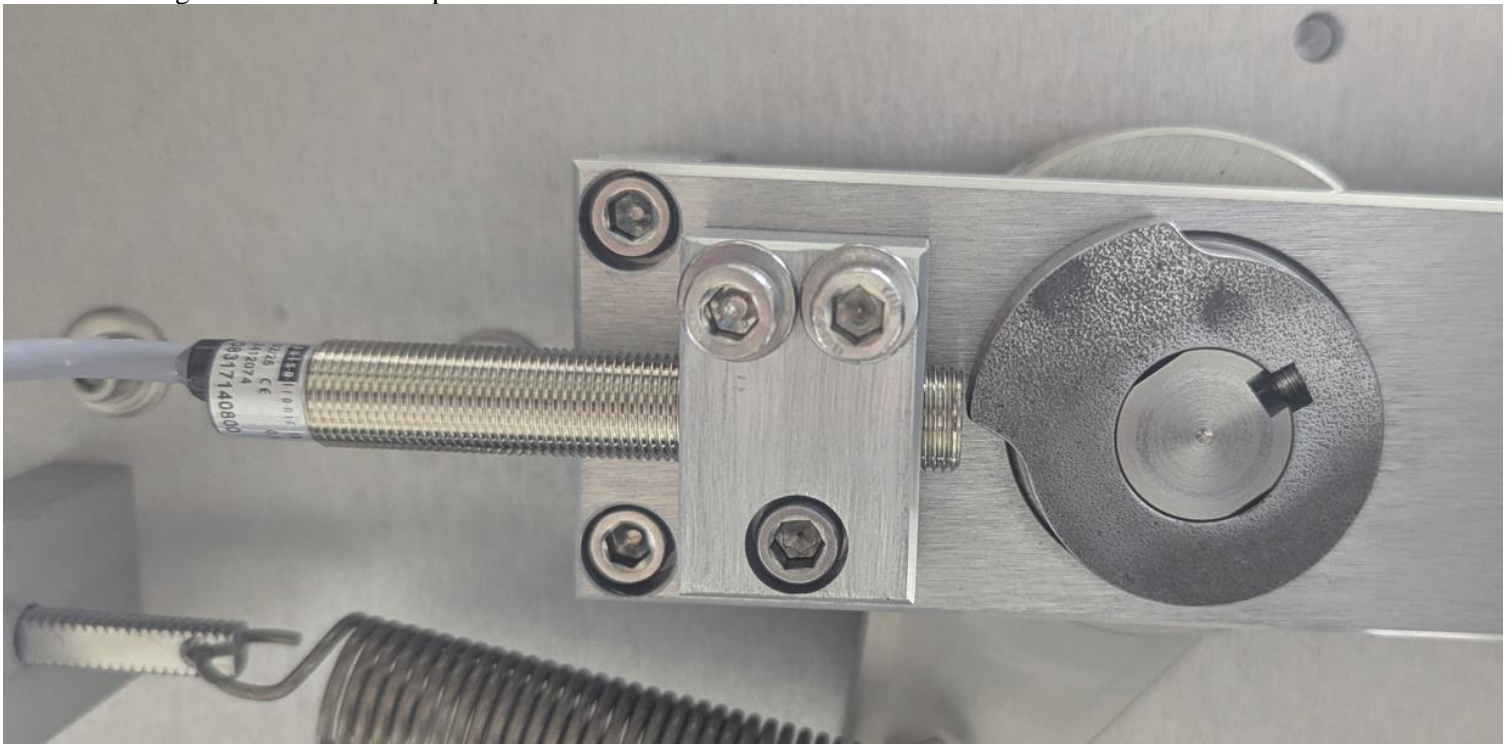



6. On the HMI go to into labeling head service menu. You will be looking at the REWIND PROX VOLTAGE (example below)

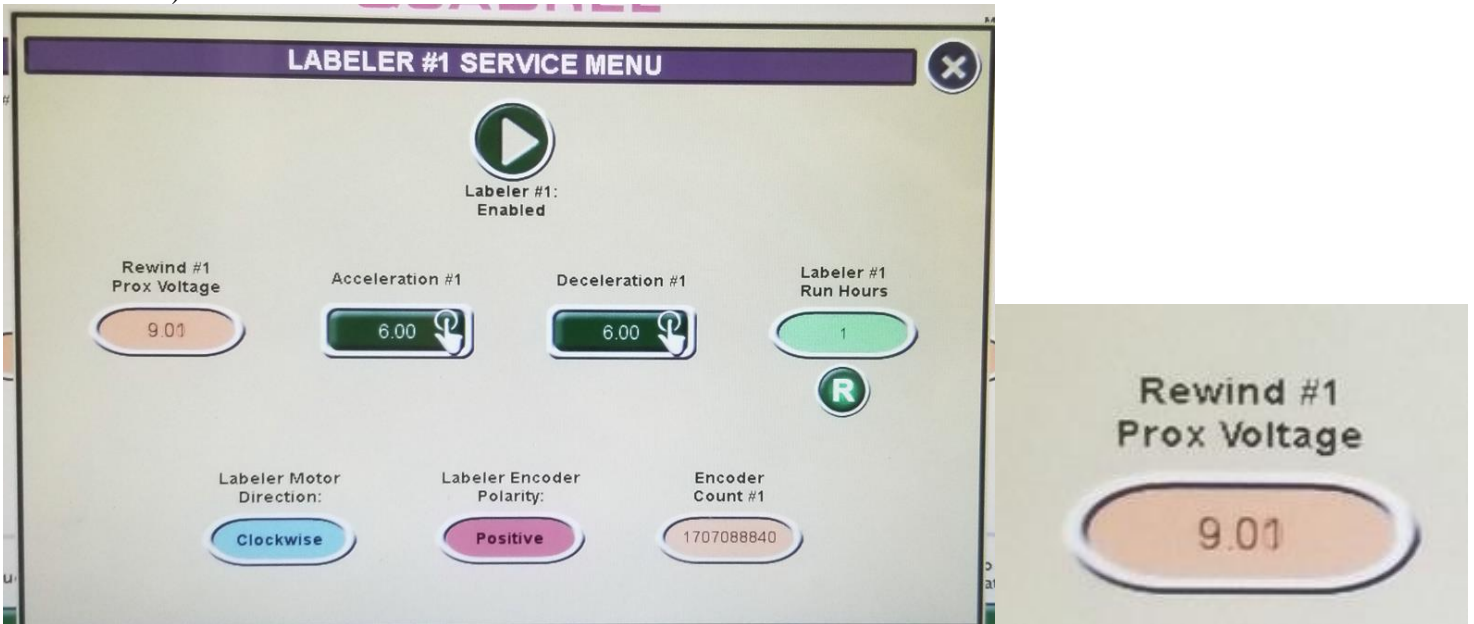

7. Adjust the sensor gap at the cam by loosening the bolt using an allen key so that the sensor can be moved forward or backward. The bolt does NOT touch the sensor. Loosening it opens the clamp so you can adjust.
8. Set the gap so the REWIND PROX VOLTAGE on the HMI reads **.90 it must be under 1 volt.**
 - a. **Retighten screw so the clamp sensor no longer moves**

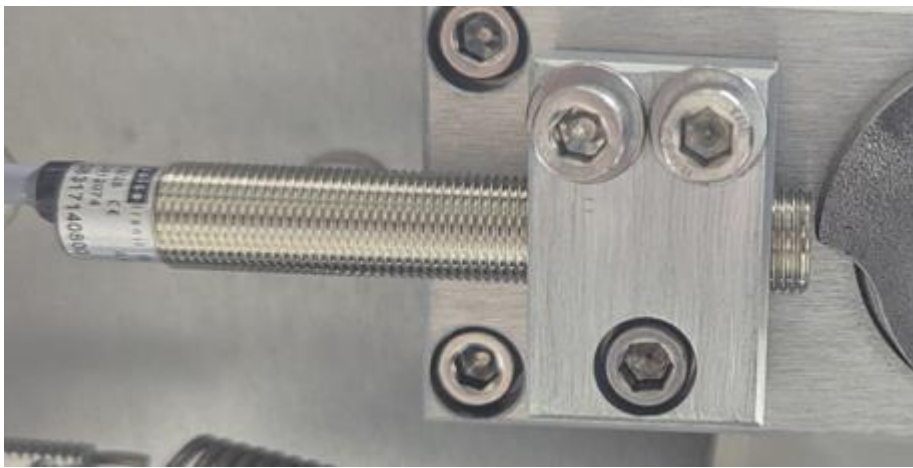

b.

9. Test by moving the rewind dancer arm forward. When doing this you should see the rewind prox voltage on the HMI increase up to 9 volts

a. If you do not see the voltage increase steadily, recheck cam sensor gap in step 7

10. Turn on rewind switch on the back of the labeler. This will engage / turn on the motor.

11. Move the rewind dancer arm forward the rewind hub should start to turn clockwise. It will slow then stop as you move forward. Rewind hub should ALWAYS be turning clockwise. If it moves counter clockwise move to **step 11a**

a. While holding the arm in the position where it started to run counter clockwise, it MUST be running counter clockwise, you will adjust **OFS1** until the rewind hub stops moving.



i.

b. This adjustment may need to be done multiple times until it no longer moves counter clockwise when rewind arm is all the forward and at rest.

9.2 BELTS

Monthly, a visual inspection of the rewind belt and timing belt, to do this depending on the labeling head you may need to remove the bottom cover on the head.

Refer to photos below.

Servo labeling head.

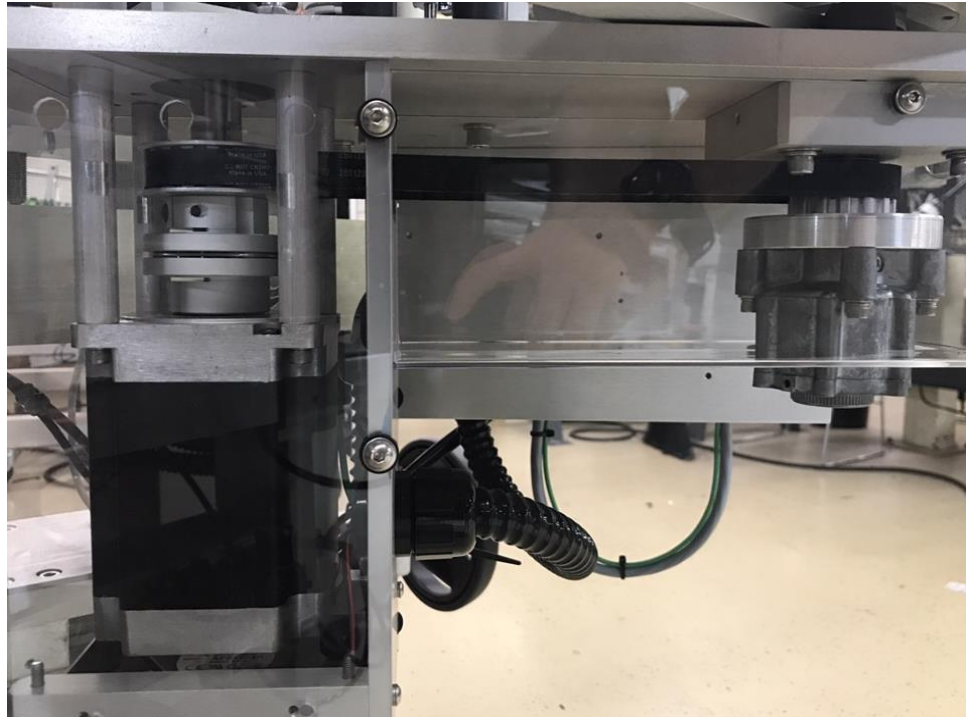

Stepping labeling head.

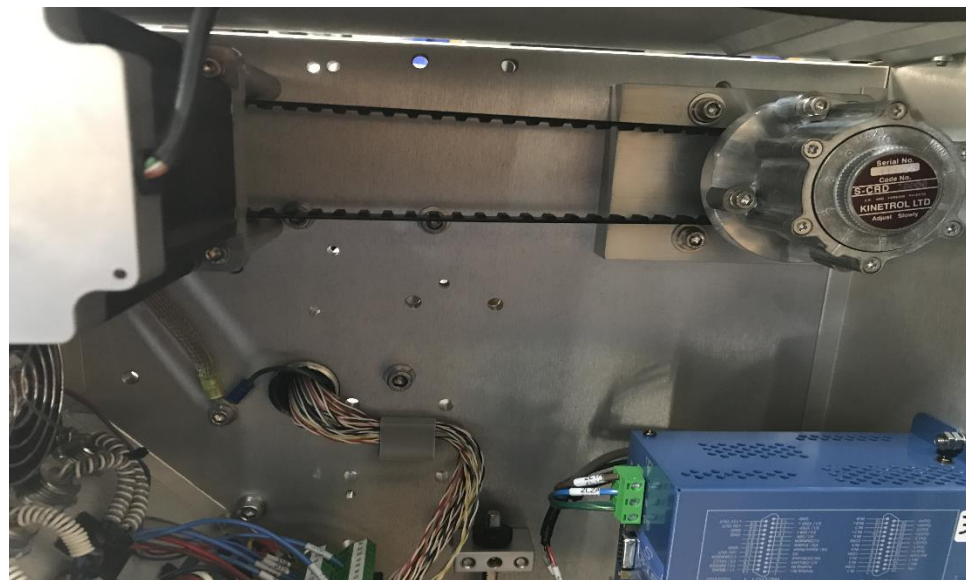

CAUTION

DO NOT ATTEMPT doing this with the equipment under tension (with power on).

The visual inspection should consist of looking for cracks or defects in the belts. If this is the case, change the belts that are defective. Refer to the parts listing in the labeling head section of this manual.

The brake band mechanism requires a monthly visual inspection as well. Also once every 12 months you should consider replacing the belt (it is possible that you may need to change it later or earlier than 12 months depending the usage of the labeling head).

The brake band belt assembly is located at the base of the unwind assembly. See images below for reference.

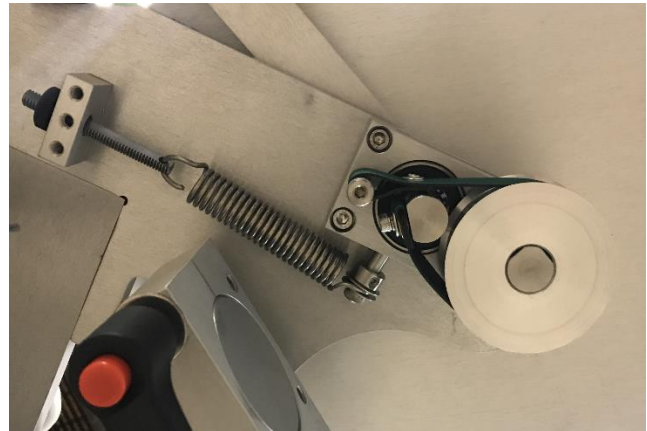
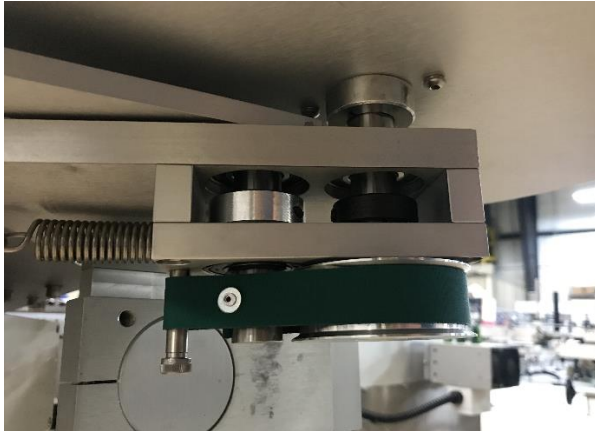

For replacement parts see the unwind assembly drawing for your labeling head in this manual.

9.3 ROLLERS

It is important that your labeler is as clean as possible in its environment in order for it to perform properly. Daily, it is suggested to clean all the rollers including the drive roller (the rubber roller), the pressure shoe and peel plate using a damp cloth with alcohol. Make sure those parts have no glue or labels on it.

Weekly, spray a silicone base lubricant on each end of the plastic bearing.

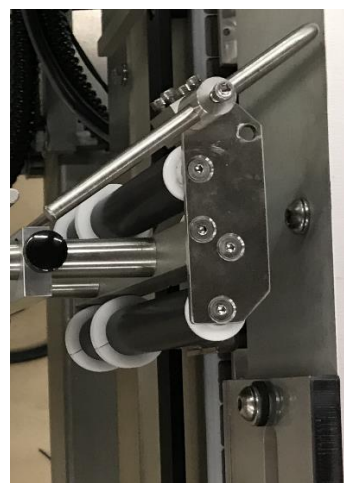
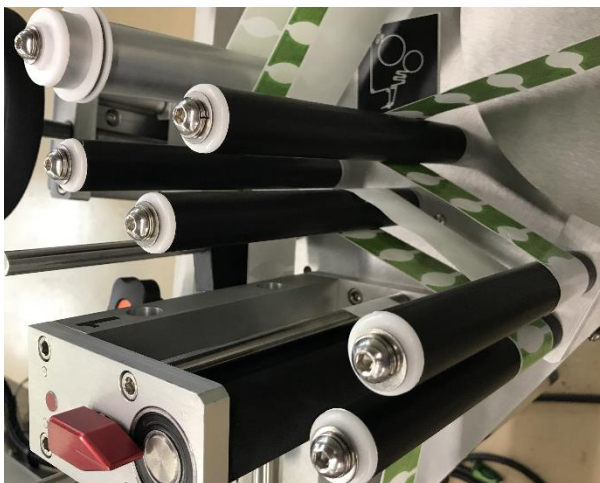

9.4 SENSORS

The sensors all have an electronic eye called a photocell; these must be free of lint or dirt. Since the photocells are generally made with glass or plastic lenses. They naturally attract substances which could easily trigger the sensor, use a cotton swap to gently clean the eye of the sensor as you would any lens, in a circular motion.

9.5 CONVEYOR

Always keep the belt or (chain) clean. To clean it simply use compressed air with an osha approved nozzle and/or damp wipes. If necessary, a soft cleaning agent can be used.

9.5.1 CLEANING

To clean the under carriage portion of the conveyor, simply remove the belt using an punch or similar tool and hammer to tap out the retaining belt link pin. (see images below, the chain has an orientation to the pins, you must tap it out from the narrow diameter) Clean the desired portion with a damp cloth and replace the pin to the belt. The pin will be tapped in the opposite side you tapped it out. *You can also lift the chain and wipe under it.

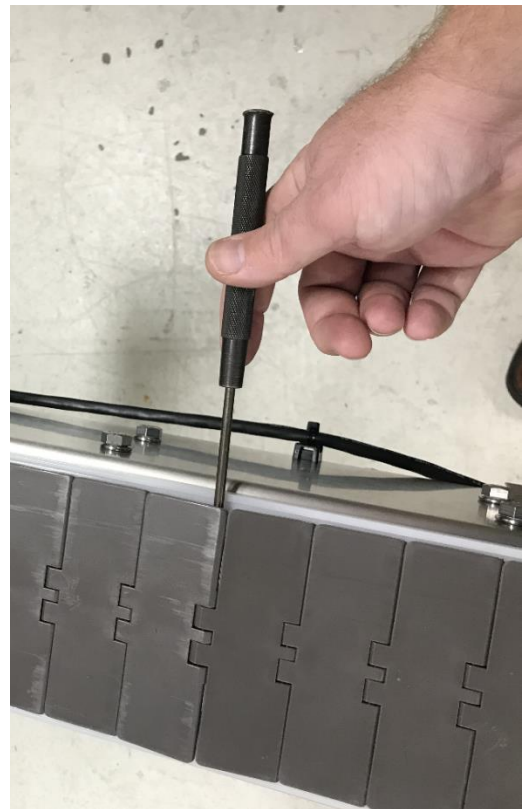
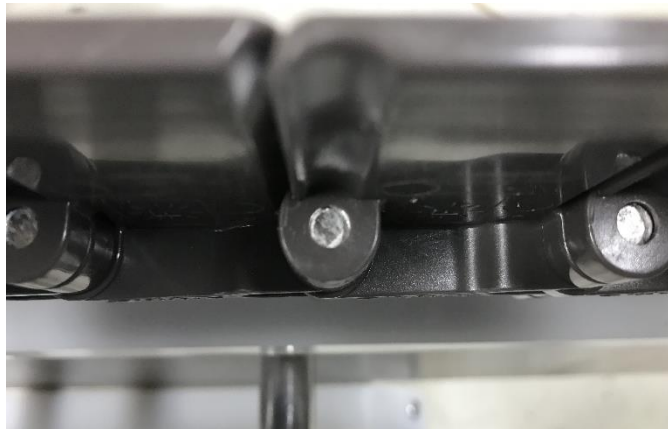

10 CLEARING A JAM

In the event a jam occurs on your Quadrel Labeler reference the following steps to clear.

1. Press the conveyor stop button or the emergency stop if you are unable to reach the stop button.
2. Clear the jam manually in the affected area of the equipment where jam is located
3. Once jam is cleared reenergize the estop, if pressed, and press the reset button (where applicable) to clear faults.
4. Put equipment back into "run" and press start to turn the system back online to continue labeling

11 WARRANTY

The standard warranty period for Quadrel equipment is 12 months following invoicing. The warranty covers all parts with consideration taken towards reasonable use and normal wear and tear. Not covered by warranty are parts that have a limited wear factor, any required labor by Quadrel. Prior to return to Quadrel, parts must be verified defective.

Return of defective parts

To return a defective part, you will need to get an RMA number from Quadrel. All RMA's are issued through our parts department. Please specify the serial number of the equipment, the client's name, address, phone number, contact name and the nature of the problem. To get a replacement part, a purchase order is required. You will be billed for the new part and credited for the defective part after return and evaluation. If the part is determined to be defective due to improper use, no credit will be issued.

Appropriate Use of Equipment

The equipment supplied to the end user by Quadrel are to be used for the sole purpose for which they were intended and must follow Quadrel's specifications on usage as well as appropriate functions. Quadrel will not assume any responsibility for any inappropriate use or modifications to the said equipment other than for the use it was initially built for. The warranty will cease to apply forthwith, in Quadrel's opinion, the equipment has been used abnormally or in an abusive manner, if it has not been properly maintained, if it has not been carried on a truck equipped with an air-ride suspension when required by Quadrel or if it has been used, or maintained contrary to the owners manual provided by Quadrel.

Responsibility Limits

The solution put forth has been prepared with the information that has been provided to Quadrel by the end user. Subsequently, Quadrel cannot assume any responsibility for the exactitude, precision, and the validity of the information which was supplied. Moreover, Quadrel cannot be responsible for (a) any damages, direct or indirect, secondary, or

accessory, including without limitations, the loss of profit, workflow interruption, loss of production, loss of profits and other; (b) any and all damages claimed against the end user by a third party; (c) any or all damages caused to the property of end user or any other third party; (d) any or all resulting in an act from the end user or third party, major force, or act of god, unforeseen cause, or event.

With all reservation, in the eventuality where the responsibility is that of Quadrel relative to any defect of quality of said equipment or proposed solution Quadrel would be able to accept the responsibility, to its entire discretion, with the replacement of part of the said equipment or solution. By a compatible or identical equipment or solution or by a reimbursement of value agreed upon. In no case can Quadrel's responsibility exceed the total monetary sums received for the said defective equipment or solution.