

T4[®]

Tabletop Wrap Labeling System for 2-1/2" Diameter or Less Products

This simple, semi-automatic labeler applies up to 40 labels per minute with a +/-1/32" placement accuracy on a wide variety of small diameter cylindrical products with a diameter of 2-1/2" or less.

Products are manually placed into the roller pockets and are presented to the labeling station by the powered roller chain conveyor. The E100 labeling head dispenses each label while the products are rotated by the powered roller impresser. Labeled products are then discharged to the product chute.

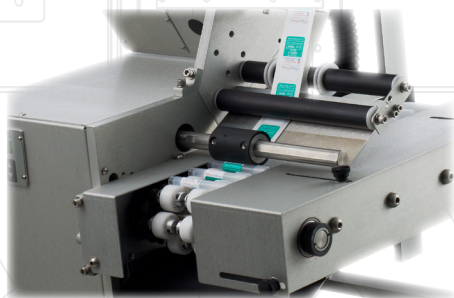

- Manually loaded, up to 40 products per minute
- Provides an economical solution to many wraparound labeling needs
- Heavy-duty construction for durability in production environments
- Simple to set up, operate and maintain
- Compact tabletop design
- Intuitive operator interface with self-teach controls

www.quadrel.com
440.602.4700

QUALITY / FLEXIBILITY

The universal roller conveyor accepts a wide variety of cylindrical products including syringes.

With 1/2" side plate construction, fully adjustable product guides and microprocessor controls, the T4 is a rugged, reliable system with simplicity of maintenance and operation.

ADVANCED CONTROLS

The T4 semi-automatic labeling system features microprocessor controls with 50 programmable product profile presets, high-torque micro-stepping motor label drive, photoelectric label detection sensor, and variable speed roller conveyor.

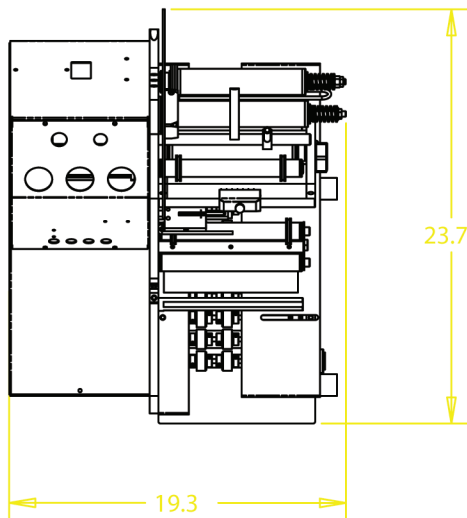

FEATURES:

E100 LABELING HEAD

- Digital Microprocessor controls
- 50 programmable presets
- Flash memory (never requires batteries)
- Digital stepping motor label drive
- Photoelectric label detection
- Quick disconnect pneumatics and sensors
- 1/2" thick anodized aluminum construction
- 12" label unwind capacity
- Modular design for simplicity of upgrades

OPTIONS

- Recommended spare parts kit
- Clear label detection sensor
- Spare parts kit
- Custom roller conveyor
- Hot stamp imprinter
- Loose-loop thermal transfer printer

PRODUCT HANDLING

- Variable speed roller conveyor
- 40 pitch, no lube, roller chain
- Sealed roller bearings

T4 SPECIFICATIONS:

Size: 19"width x 27" length x 24" height

Approximate Net Shipping Weight: 75 lbs.

Actual Labeling Rate: Dependent upon operator dexterity (up to 40 products per minute)

Accuracy: Up to +/-1/32" @ Sigma 2

Dispensing Speed: 310" per minute

Label Dimensions:

Maximum width = 6-1/8"

Minimum width 1/2"

Minimum length = 1/2"

Roll Capacity: 12" O.D.

Label Format: Die cut, waste removed (minimum 1/8" [3mm] between labels)

Electronic Utilities: 115 VAC or 220 VAC, 50/60Hz, 10/5 amps (Must specify at time of order)

Pneumatic Utilities: 80 psi @ 5 CFM clean dry compressed air (also available with non pneumatic actuators)

