

## Q65 Label Applicator

The Q65 label applicator was designed to provide years of reliable, 24/7 operation in harsh environments with minimal maintenance. It is ideal for stand alone applications on existing packaging lines, as well as the labeler of choice for a Quadrel high speed open frame system.

Design features such as built-in electronics, 16" label unwind, high-speed microprocessor and high-torque stepping motor label drive allow for production rates up to 300 parts per minute with +/-1/32" dispensing accuracy.



- Robust stainless steel and anodized aluminum construction
- Microprocessor controls with password protected menus
- 50 programmable product presets
- Pivoting peel plate with integrated label impresser
- Outboard supported label drive with sealed roller bearings
- Quick disconnect electronics with integrated optical sensors
- Integrated U-Mount style mounting yoke

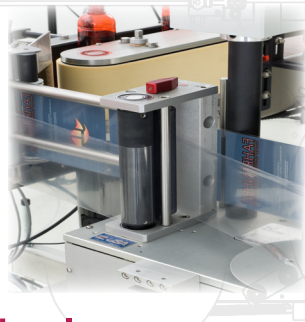

[www.quadrel.com](http://www.quadrel.com)  
440.602.4700

## QUALITY/ FLEXIBILITY

The Q65 label applicator was designed to provide years of reliable, 24/7 operation in harsh environments with minimal maintenance.

Portability and simplicity of operation make the Q65 an ideal choice for integration into existing packaging lines as well as a wide variety of OEM applications.

## ADVANCED CONTROLS

The high-speed M3 microprocessor directs and monitors all functions of the labeling head, including "Self Teach" setup, missing label on web detection and full status monitoring. With memory for 50 product presets, the M3 easily accommodates a wide variety of applications. An optional encoder package electronically synchronizes the Q65 to changing line speeds.

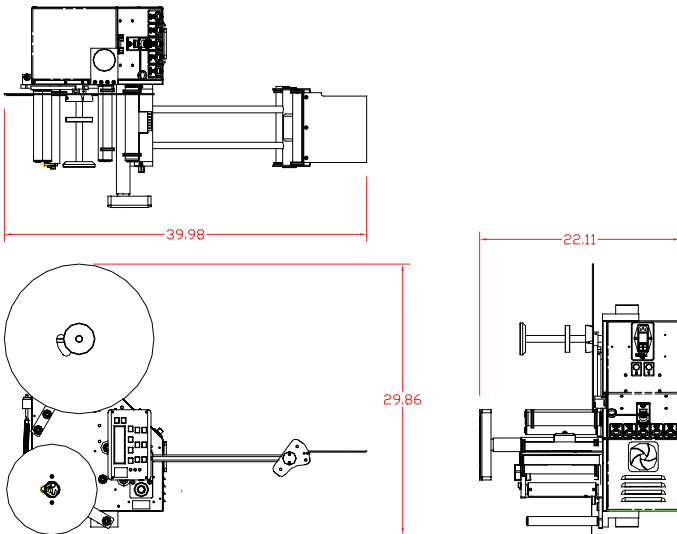

## STANDARD FEATURES

- Stepping motor label drive
- Encoder-based speed compensation
- Pivoting peel plate for maximum flexibility
- Rugged stainless steel & aluminum construction
- Precision sealed bearings
- Outboard supported drive yoke for long-term reliability and consistent web tracking
- Dependable performance in harsh environments
- 16" label unwind for less frequent roll changes
- Optical label detection sensor
- Adjustable Hydraulic waste rewind clutch
- Integrated fan-cooled electronics
- Fatal fault relay interface

## OPTIONS

- Left or Right hand versions
- T or H-Base stand with casters and leveling pads
- Low label detection
- End-of-web detection
- Broken web detection
- Thermal Transfer, Laser, or Inkjet printer
- Hot stamp imprinter
- Clear label detection
- Powered waste rewind assembly
- 20" label unwind capacity
- Push-Pull label drive
- Consult factory for additional options

## SPECIFICATIONS

**Size:** 36.6" width x 35" length

**Approximate Net Shipping Weight:** 80 lbs. (36kg)

**Actual Labeling Rate:** Dependent upon label length and product size (Up to 350 products per minute)

**Dispensing Accuracy:** Up to +/-1/32"

**Dispensing Speed:** Variable, up to 2200" per minute

**Label Drive:** Digital stepping motor

**Design Features:** Outboard supported label drive, stainless steel/ aluminum construction, precision sealed bearings, pivoting peel plate

**Label Sensing:** Photoelectric

**Utilities:** 110VAC or 220VAC, 50/60Hz, 10/5 amps (Must specify at time of order)

**Label Requirements:**

Maximum width = 6 7/8" , 9 7/8" optional

Maximum length = required length

Minimum width 1/2"

Minimum length = 1/2"

**Roll Capacity:** 16" O.D. on 3" or 6" I.D. core (Must specify at time of order)

**Web Width:** 7" , 10" optional

**Label Format:** Die cut, waste removed (Minimum 1/8" between labels)

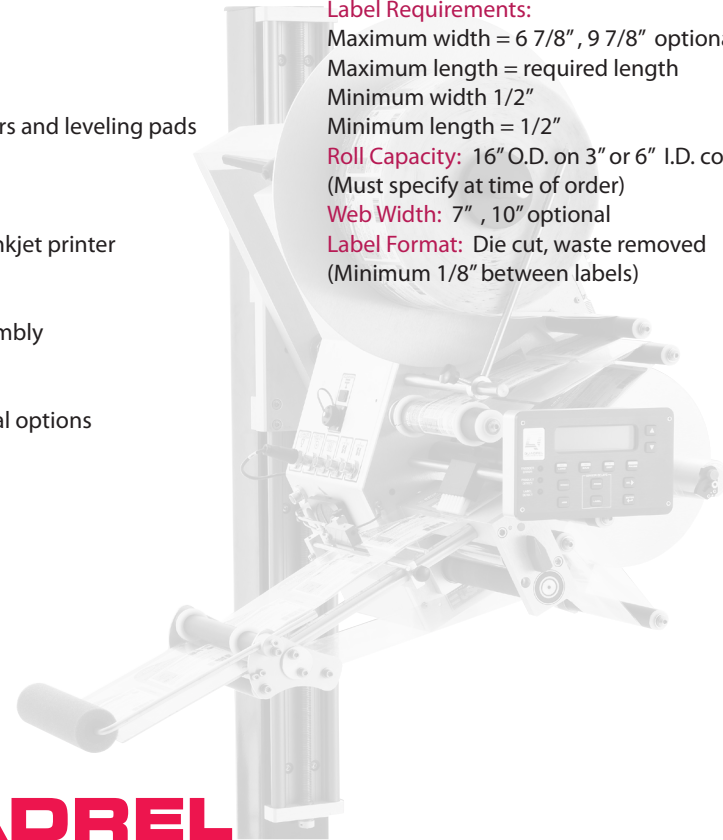

**QUADREL**  
LABELING SYSTEMS

