

Q60 Label Applicator

The Q60 label applicator is a rugged, state-of-the-art label applicator for extremely high speeds and 24/7 reliability in the harshest environments. The modular design and panel mounted electronics make it ideal for Quadrel's rotary, high speed in-line or custom systems.

The Q60 label applicator is available with customer specified PLC controls, (Allen Bradley®, Siemens® or Mitsubishi®) Emerson® Servo or stepping motor drive, push/pull web handling (for today's thin film liners), remote unwinds, powered rewinds, vacuum waste removal as well as a wide array of cautionary and fatal faults.

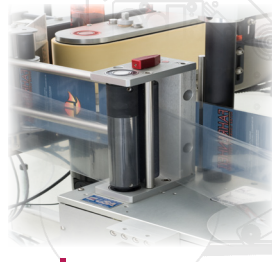
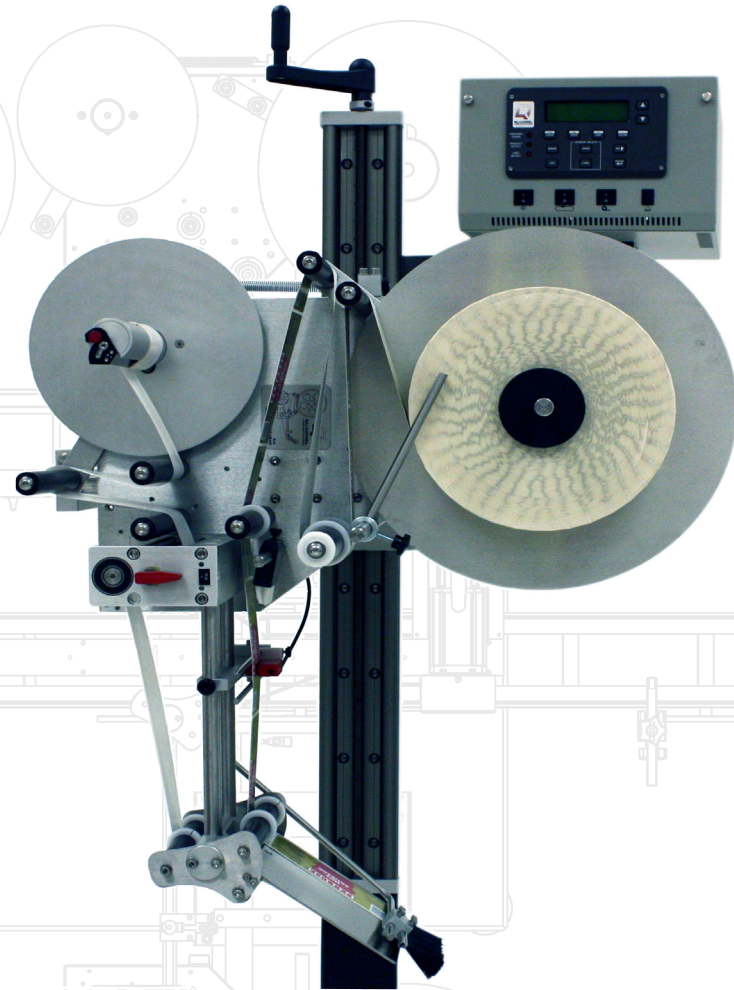

- Robust stainless steel and anodized aluminum construction
- Intelligent motor controller
- 50 programmable product profile presets
- Pivoting peel plate with integrated label impresser
- Outboard supported label drive with sealed roller bearings
- Quick disconnect electronics with integrated optical sensors
- Integrated U-Mount style mounting yoke

www.quadrel.com
440.602.4700

Capabilities

24/7 RELIABILITY

This labeling head provides proven 24/7 reliability in a modular package. In addition, the Q60 label applicator offers the flexibility to use one of the most popular labeling heads in the industry in a wide variety of applications.

Ideally suited for cabinet-based system integrations and a wide variety of OEM applications, the Q60 labeling head is the label applicator of choice for continuous operation in demanding environments with minimal maintenance.

ADVANCED CONTROLS

The high-speed M2 microprocessor directs and monitors all functions of the labeling head, including "Self Teach" setup, missing label on web detection, and full status monitoring. With memory for 50 product/ label presets, the M2 easily accommodates a wide variety of options. With the addition of an encoder, the M2 controller seamlessly coordinates line speed variations with the labeling head functions.

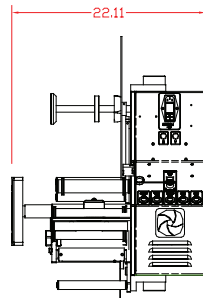
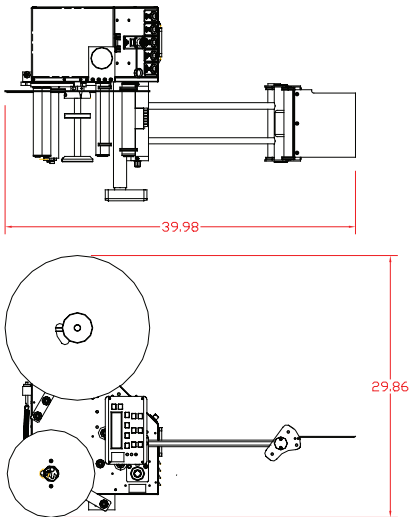

FEATURES:

- Intelligent stepper or servo label drive
- Encoder-based speed compensation (with optional encoder)
- Pivoting peel plate for maximum flexibility
- Rugged stainless steel & aluminum construction
- Precision sealed bearings
- Outboard supported drive yoke for long-term reliability and consistent web tracking
- Dependable performance in harsh environments
- 16" (406mm) label unwind for less frequent roll changes
- Optical label detection sensor
- Adjustable hydraulic waste rewind clutch
- Integrated fan-cooled electronics
- Fatal fault relay interface

OPTIONS:

- Left or Right hand versions
- T or H-Base stand with casters and leveling pads
- Intelligent Servo label drive
- Low label detection
- End of web detection
- Broken web detection
- Touch Screen operator interface
- Thermal transfer, laser, or hot stamp imprinter
- Clear label detection
- Powered waste rewind assembly
- 20" label unwind capacity
- Push Pull label drive
- Consult factory for others

Q60 SPECIFICATIONS:

- Size:** 36.6" (929mm) width x 35" (889mm) length
- Approximate Net Shipping Weight:** 80 lbs. (36kg)
- Actual Labeling Rate:** Dependent upon label length and product size (Up to 350 products per minute)
- Dispensing Accuracy:** Up to +/- 1/32" (1mm)
- Dispensing Speed:** Variable, up to 2200" per minute
- Label Drive:** Digital stepping motor standard
- Design Features:** Outboard supported label drive, stainless steel/aluminum construction, precision sealed bearing, pivoting peel plate
- Label Dimensions:**
 - Maximum width = 6 7/8" (174mm), 9 7/8" (254mm) optional
 - Maximum length = required length
 - Minimum width 1/2" (13mm)
 - Minimum length = 1/2" (13mm)
- Roll Capacity:** 16" (406mm) O.D. on 3" (76mm) or 6" (153mm) I.D. core. (Must specify at time of order)
- Web Width:** 7" (177mm), 10" (254mm) optional
- Label Format:** Die cut, waste removed (Minimum 1/8" [3mm] between labels)
- Label Sensing:** Photoelectric
- Utilities:** 110vac or 220vac, 50/60Hz, 10/5 amps (Must specify at time of order)

